



GE
Critical Power

***Remote Peripheral Monitoring
(RPM) System
J85501G-1***

Product Manual

Product Manual
107570517
Issue 10
February 2015

Remote Peripheral Monitoring
(RPM) System
J85501G-1

Table of Contents

1 Introduction

<i>RPM System and Components</i>	<i>1 - 1</i>
<i>Functions of the RPM Modules</i>	<i>1 - 1</i>
<i>Types of RPM Modules</i>	<i>1 - 1</i>
<i>Reference Documents</i>	<i>1 - 2</i>
<i>Contact Information</i>	<i>1 - 2</i>

2 Product Description

<i>Overview</i>	<i>2 - 1</i>
<i>Types of Modules</i>	<i>2 - 1</i>
<i>Voltage Modules</i>	<i>2 - 1</i>
<i>Shunt Module</i>	<i>2 - 2</i>
<i>Transducer Module</i>	<i>2 - 2</i>
<i>Binary Module</i>	<i>2 - 2</i>
<i>Temperature Module</i>	<i>2 - 2</i>
<i>Control Relay Module</i>	<i>2 - 3</i>
<i>Module Specifications</i>	<i>2 - 4</i>
<i>Available RPM Modules</i>	<i>2 - 4</i>
<i>210 through 212 Series</i>	<i>2 - 5</i>
<i>Module Kits</i>	<i>2 - 6</i>
<i>Introduction</i>	<i>2 - 6</i>
<i>Voltage Modules (L22, L24, L25, L26)</i>	<i>2 - 6</i>
<i>Shunt Module (L21)</i>	<i>2 - 6</i>
<i>Transducer Module (L23)</i>	<i>2 - 6</i>
<i>Binary Module (L27)</i>	<i>2 - 6</i>
<i>Temperature Module (L28)</i>	<i>2 - 7</i>
<i>Control Relay Module (L9)</i>	<i>2 - 7</i>
<i>Connection Units</i>	<i>2 - 8</i>
<i>What Is a Connection Unit?</i>	<i>2 - 8</i>
<i>Types of Connection Units</i>	<i>2 - 8</i>
<i>Current Limiting Resistors</i>	<i>2 - 9</i>
<i>Introduction</i>	<i>2 - 9</i>
<i>Control Relay Module</i>	<i>2 - 9</i>
<i>Temperature Module</i>	<i>2 - 9</i>

<i>Voltage, Binary, Transducer, and Shunt Modules</i>	2 - 9
<i>GPS Cabinet Shunts</i>	2 - 9
<i>Mounting Panels</i>	2 - 10
<i>Introduction</i>	2 - 10
<i>Panel Descriptions</i>	2 - 10
<i>Replacement Modules</i>	2 - 11
<i>Ordering Information</i>	2 - 11
3 <i>Engineering an RPM System</i>	
<i>Planning the RPM System Installation</i>	3 - 1
<i>Overview</i>	3 - 1
<i>Galaxy Controller Support</i>	3 - 1
<i>Current Consumption</i>	3 - 2
<i>Configuration Guideline</i>	3 - 2
<i>Application Specific Configurations</i>	3 - 2
4 <i>Safety</i>	
<i>Safety Statements</i>	4 - 1
<i>Warning</i>	4 - 3
<i>Precautions</i>	4 - 4
5 <i>Installation</i>	
<i>Installation Preparations</i>	5 - 1
<i>Installation Materials</i>	5 - 1
<i>Safety</i>	5 - 1
<i>Replacements or Additions to an RPM System</i>	5 - 2
<i>Monitoring/ Control Units</i>	5 - 2
<i>Connection Units or Bus</i>	5 - 2
<i>New Module Added to End of a Bus</i>	5 - 2
<i>Mounting the Modules</i>	5 - 3
<i>Location</i>	5 - 3
<i>Optional Panel or Brackets</i>	5 - 3
<i>Making TB101 and TB102 Connections</i>	5 - 4
<i>TB101</i>	5 - 4
<i>TB102</i>	5 - 4
<i>Terminating the Final Module</i>	5 - 10
<i>Assigning Module Addresses</i>	5 - 11
<i>Using Unique Addresses</i>	5 - 11
<i>SW1 and SW2</i>	5 - 11
<i>Hexadecimal Numbers and Letters</i>	5 - 11
<i>Installing Current Limiting Resistors</i>	5 - 12
<i>Voltage, Shunt, and Transducer Modules</i>	5 - 12
<i>Binary Module</i>	5 - 13

<i>Initialization Sequence</i>	5 - 19
<i>Rapid Cycling of the Green LED</i>	5 - 19
<i>Continuous Illumination of the Green LED</i>	5 - 19
<i>Slow Cycling of the Green LED</i>	5 - 19

6 Troubleshooting

Appendix A Decimal/Hexadecimal Conversion Table

Appendix B AC Interface Units

<i>Applications</i>	B - 1
<i>Functions of the Units</i>	B - 1
<i>Programming Examples</i>	B - 1
<i>Available Units</i>	B - 2
<i>Overview</i>	B - 2
<i>Voltage Interface Unit</i>	B - 2
<i>Current Interface Unit</i>	B - 2
<i>Frequency Interface Unit</i>	B - 3
<i>Voltage/Current Interface Unit</i>	B - 3
<i>Installation</i>	B - 4
<i>Introduction</i>	B - 4
<i>Required Components</i>	B - 4
<i>Mounting</i>	B - 4
<i>Wiring</i>	B - 4
<i>Ordering Information</i>	B - 5
<i>Ordering the Units</i>	B - 5
<i>Receiving the Units</i>	B - 5

List of Figures

<i>Figure 3-1: Maximum Number of Modules Per Bus Versus Bus Length</i>	3 - 2
<i>Figure 5-1: Mounting Panel and Brackets</i>	5 - 3
<i>Figure 5-2: Connection Unit for Voltage, Shunt, Transducer, and Binary Modules</i>	5 - 6
<i>Figure 5-3: Connection Unit for Temperature Module Only</i>	5 - 7
<i>Figure 5-4: Connection Unit for Control Relay Module Only</i>	5 - 8
<i>Figure 5-5: Connection to the Controller (All Modules)</i>	5 - 9
<i>Figure 5-6: Switches for Setting Hexadecimal Addresses</i>	5 - 11
<i>Figure 5-7: DC Plant Voltage Monitoring</i>	5 - 12
<i>Figure 5-8: DC Plant Load Monitoring</i>	5 - 12
<i>Figure 5-9: Functional Schematic for One Channel of a 222A Binary Module</i>	5 - 13
<i>Figure 5-10: Isolated Alarm Contact Monitoring Using a 222A Binary Module</i>	5 - 13
<i>Figure 5-11: Monitoring a Ground-sending Alarm Point Shared with Another Alarm System Using a 222A Binary Module</i>	5 - 14
<i>Figure 5-12: Sharing a Loop-closure Alarm with Another Alarm System (222A Binary Module)</i>	5 - 15
<i>Figure 5-13: Monitoring an Isolated Ground-sending Alarm Contact Using a 222A Binary Module</i>	5 - 15
<i>Figure 5-14: Monitoring the Presence or Absence of Voltage on a Resistor, Lamp or Relay Coil Using a 222A Binary Module</i>	5 - 16
<i>Figure 5-15: Monitoring an Isolated -48V Fuse Alarm or Other -48V-sending Alarm Contact Using a 222A Binary Module</i>	5 - 17
<i>Figure 5-16: RPM Module Top and Base</i>	5 - 18

List of Tables

<i>Table 2-A: Remote Peripheral Monitoring Modules</i>	<i>2 - 4</i>
<i>Table 2-B: 210-212 Series RPM Modules</i>	<i>2 - 5</i>
<i>Table 2-C: Connection Units</i>	<i>2 - 8</i>
<i>Table 2-D: Mounting Panels</i>	<i>2 - 10</i>
<i>Table 2-E: Replacement RPM Modules</i>	<i>2 - 11</i>
<i>Table 6-A: Troubleshooting</i>	<i>6 - 1</i>
<i>Table A-1: Decimal/Hexadecimal Conversion</i>	<i>A - 1</i>

1 Introduction

RPM System and Components

Functions of the RPM Modules

The RPM modules provide data acquisition and control functions for power applications. The user can program various alarm and control functions with the modules when they are used with a Galaxy controller. The modules, which communicate back to the controller, are physically connected in a daisy-chain bus configuration. System capacity is added in a modular fashion with measurement and control modules.

Types of RPM Modules

There are several types of RPM modules available:

- Voltage
- Shunt
- Transducer
- Binary
- Temperature
- Control Relay

Reference Documents

Product manuals, product line brochures, and software are available on-line at www.gecriticalpower.com

Software includes Easy View and SNMP MIB

Document	Title
	Infinity M Product Line Brochure – Specifications and Ordering Guide
H5692448-AD	NE System, 24V and/or 48V Assembly Drawing
CC848815341	Galaxy Pulsar Plus Family Product Manual
108994645	Galaxy Millennium II Installation and User's Guide

Contact Information

Phone: +1 888 546-3243

Email: PE.TechSupport@ge.com

Web site: www.gecriticalpower.com

2 *Product Description*

Overview

Types of Modules

There are several types of Remote Peripheral Monitoring (RPM) Modules:

- Voltage
- Shunt
- Transducer
- Binary
- Temperature
- Control Relay

The ranges and accuracies of each module are listed in Table 2-A.

Voltage Modules

A Voltage Module measures dc voltage. Each module has six different voltage input channels that are used as inputs to measure external voltage, based on the range of the module in use. Each module also has one channel that measures external temperature using a thermistor.

Each channel has positive and negative terminals. Polarity of channels is critical for voltage measurements.

There are four different Voltage Modules: 221A, 221B, 221C, and 221D.

Overview, continued

Shunt Module

The 221F Shunt Module measures dc current. The measuring channels measure shunt voltage within the range of -50 to +150mV, and use the shunt size to derive the current. The module has six measuring channels and one external temperature channel.

Each channel has positive and negative terminals. Polarity of channels is critical for voltage measurements.

Transducer Module

The 221J Transducer Module can monitor up to six transducers with millivolt outputs ranging from 0 to 100 millivolts. The module has one external temperature channel.

Note: Transducers for use with the 221J Transducer Module must be provided separately. See Appendix B for more information about available transducers.

Binary Module

The 222A Binary Module is designed to measure six differential binary channels and one temperature channel.

The six binary channels are polarity sensitive. All externally powered points measured by a Binary Module must be of the same polarity.

For monitoring of contacts without a voltage potential (dry contacts), the Binary Module provides a +5Vdc biasing voltage. The +5Vdc bias is isolated from the bus. If there is voltage on both positive and negative potentials of the points to be monitored, e.g., lamps, coils, etc., multiple Binary Modules must be used.

Temperature Module

The 223T Temperature Module has seven channels to measure the temperature of seven different points in the system. Each channel must be connected to a 100K thermistor or ring-type probe, which must be ordered separately.

The cable length should be limited to 120 ohms per wire.

The Temperature Module can measure temperatures within the range of -40°C to +70°C with a tolerance of $\pm 1^\circ\text{C}$. Polarity of channels is not critical for temperature measurements.

Overview, continued

Control Relay Module

The 214A Control Relay Module contains three separate Form-C relay contacts for controlling external equipment. The controller's configuration of the ON and OFF modes determines the state of the three relays' normally closed (NC), normally open (NO), and COM contacts.

- The ON mode:
 - disconnects NC from COM
 - connects NO to COM
- The OFF mode:
 - disconnects NO from COM
 - connects NC to COM
- During module power-up and power-down, all three relays are placed in the controller OFF mode.

Module Specifications

Available RPM Modules

Table 2-A gives the specifications for the available RPM modules.

Table 2-A: Remote Peripheral Monitoring Modules

Type of Module	Module No.	Input Voltage Range*	Measurement Accuracy**
Voltage	221A	0 - 3 Vdc	± 5 mVdc
	221B	0 - 16 Vdc	± 25 mVdc
	221C	0 - 70 Vdc	± 50 mVdc
	221D	0 - 200 Vdc	± 150 mVdc
Shunt	221F	-50 to +150 mVdc†	±0.55 mVdc
Transducer	221J	0 - 100 mVdc	±0.55 mVdc
Binary	222A	5 - 200 Vdc	±1.5 Vdc
Type of Module	Module No.	Input Temperature Range	Measurement Accuracy**
Temperature	223T	-40°C to +70°C	±1°C
Type of Module	Module No.	Input Voltage Range‡	Input Current Range‡
Control Relay	214A	0 - 110 Vdc	±0 - 0.3 Adc
<p>*All measurement modules are calibrated with respect to positive voltages. To measure a negative voltage, the connection to the measurement point should be reversed and the reading should be multiplied by -1. The dc voltage between any two input terminals must not exceed 200 Vdc.</p> <p>**All measurement accuracies are valid in the temperature range of 0°C to +40°C. Measurement accuracies will degrade for 221A/B/C/D in the extended temperature range of -40°C to +70°C.</p> <p>†Although the bipolar shunt module is able to measure an input voltage as low as -100 mVdc, the Galaxy controller software will raise an alarm indicating measurement out of range. This alarm may be ignored as long as the input voltage is within the range of -100 mVdc to +150 mVdc.</p> <p>‡The input voltage and current ranges for the 214A Control Relay module are valid in the temperature range of -40°C to +70°C.</p>			

Module Specifications, continued**210 through 212 Series**

Table 2-B lists the specifications for the 210 through 212 series of RPM modules, which were replaced by the 221 through 222 series. For additional information on the older modules described in Table 2-B, call GE Critical Power Technical Support.

Table 2-B: 210-212 Series RPM Modules

Module	Input Voltage Range	Measurement Accuracy
210D Voltage Module	0 - 200 Vdc	± 150 mVdc
210F Shunt Module	0 - 110 mVdc	± 0.55 mVdc
210J Transducer Module	0 - 100 mVdc	± 0.55 mVdc
211A Voltage Module	0 - 3 Vdc	± 5 mVdc
211B Voltage Module	0 -16 Vdc	± 25 mVdc
211C Voltage Module	0 - 70 Vdc	± 50 mVdc
211F Bipolar Module	-50 - +150 mVdc	± 0.55 mVdc
212A Binary Module	0 - 200 Vdc	± 1.5 Vdc

Module Kits

Introduction

Modules consist of two sections, the actual measurement/control unit (top) and a connection unit (base).

The RPM modules are ordered by list number from the J85501G-1 drawing, and are delivered as kits. In addition to the monitoring unit and connection unit of the module itself, the kits contain other items, which are listed below.

Voltage Modules (L22, L24, L25, L26)

- Six (6) 100K current limiting resistor assemblies (847540424)
- One (1) temperature thermistor (407209808)
- Twenty-four (24) butt splices
- Two (2) cable ties
- One (1) velcro loop

Shunt Module (L21)

- Six (6) 100K current limiting resistor assemblies (847568920)
- One (1) temperature thermistor (407209808)
- Two (2) cable ties
- One (1) velcro loop

Transducer Module (L23)

- Six (6) 100K current limiting resistor assemblies (847540424)
- One (1) temperature thermistor (407209808)
- Twenty-four (24) butt splices
- Two (2) cable ties
- One (1) velcro loop

Note: Transducers for use with the 221J Transducer Module must be provided separately. See Appendix B for more information about available transducers (AC Interface Units).

Binary Module (L27)

- Six (6) 100K current limiting resistor assemblies (847540424)
- One (1) temperature thermistor (407209808)
- Twenty-four (24) butt splices
- Two (2) cable ties
- One (1) velcro loop

Module Kits, continued

Temperature Module (L28)

- Two (2) cable ties
- One (1) velcro loop

Note: Order thermal probe (407209808) or ring-type probe and connection cable assembly (847917879/847307410) separately for use with the Temperature Module.

Control Relay Module (L9)

- Two (2) cable ties
- One (1) velcro loop

Connection Units

What Is a Connection Unit?

A module consists of two parts: the measuring device itself and the base (connection unit).

Types of Connection Units

There are two types of connection units available for various module types. Table 2-C shows the module types and the corresponding connection units.

Table 2-C: Connection Units

Module Type(s)	Module Code(s)	Connection Unit Comcode
Voltage	221A/B/C/D	847635851
Shunt	221F	
Transducer	221J	
Binary	222A	
Temperature	223T	
Control Relay*	214A	847629342
*For the 214A Control Relay Module, the maximum relay contact voltage is 110Vdc and maximum current is 0.3Adc. Wiring depends on the voltage, current, local building codes, and various other characteristics of the controlled point.		

Current Limiting Resistors

Introduction

Current limiting resistors provide short circuit protection for wiring between the measuring points and the RPM modules. The resistors are required at the power source for the circuit to meet NEC Class 2 circuit requirements.

Control Relay Module

Current limiting resistors **are not required** for the Control Relay Module. Refer to the specific controller manual for the programming and implementation of the Control Relay Module.

Temperature Module

Current limiting resistors **are not required** for the Temperature Module.

Voltage, Binary, Transducer, and Shunt Modules

Current limiting resistors (100K ohms) **are required** for the measurement inputs of the Voltage, most Binary, Transducer, and Shunt Module applications.

- Comcode 847540424 current limiting resistor assemblies are used (one per measurement channel) with the Voltage, most Binary, and Transducer Modules applications. Each assembly contains two 100K-ohm resistors terminated in butt splices on both ends.
- Comcode 847568920 current limiting resistor assemblies are used (one per measurement channel) with the Shunt Module. Each assembly contains two 100K-ohm resistors terminated in a butt splice on one end and terminals for connection to KS-22012 circuit breakers on the other end.

GPS Cabinet Shunts

All shunts (load and battery) and some voltage points that are provided with the GPS cabinets already have current limiting resistors; check the T-83314-30 drawing for resistor presence.

Mounting Panels

Introduction The RPM modules can be mounted in a variety of mounting panels.

Panel Descriptions Table 2-D describes the panels used for mounting the RPM modules.

Table 2-D: Mounting Panels

J85501G-1 List No.	Description of Panel
K1	Panel for mounting 7 modules in a 26-inch/66cm frame with 24.2-inch/61.5cm mounting centers horizontally, and 1-inch/2.54cm centers vertically (6-inch/15.24cm height)
K2	Mounting bracket for one module on a frame with 1-inch/2.54cm mounting centers (4-inch/10.16cm height)
K3	Mounting bracket for one module on a frame with 1-inch/2.54cm mounting centers (6-inch/15.24cm height)
Comcode	Description of Panel
848285854	Panel for mounting 6 modules on the top of a GPS cabinet (23.6 inch/59.9cm wide)
848412367	White panel for mounting 6 modules in a 23-inch/58.4cm frame with 22.9-inch/58.2cm mounting centers horizontally, and 1-inch/2.54cm centers vertically (6-inch/15.24cm height)
108984477	Grey panel for mounting 6 modules in a 23-inch/58.4cm frame with 22.9-inch/58.2cm mounting centers horizontally, and 1-inch/2.54cm centers vertically (6-inch/15.24cm height)

Replacement Modules

Ordering Information

Table 2-E lists the comcodes for ordering replacement RPM modules.

Table 2-E: Replacement RPM Modules

Module	Comcode
Voltage (221A)	108040890
Voltage (221B)	108040908
Voltage (221C)	108040916
Voltage (221D)	108040924
Shunt (221F)	108040932
Transducer (221J)	108040940
Binary (222A)	108040957
Temperature (223T)	108274242
Control Relay (214A)	107307555

3 *Engineering an RPM System*

Planning the RPM System Installation

Overview

The number of RPM modules that can be installed in a system depends on two things:

- which Galaxy controller is used to monitor and control the system
- current consumed on the communication bus

Galaxy Controller Support

Each of the Galaxy controllers supports a different number of RPM modules:

- A Galaxy SC controller can support one, two, or three buses of RPM modules. Up to 95 RPM modules can be installed on any one bus, but the total number of modules installed on all three buses cannot exceed a total of 255. Each bus can have a maximum reach of 300 meters. Figure 3-1 illustrates the relationship of distance to number of modules.

Note: There is no need to use more than one bus unless more modules need to be installed than a given bus length can support. However, multiple buses can be used for convenience or to simplify installation of modules when monitoring points are located in different directions. Modules should be evenly distributed along the length of the bus when possible.

- A Millennium controller can support only one bus of RPM modules with a maximum of 95 modules on the bus. The bus has a maximum reach of 300 meters.
- The Galaxy Vector Controller does not support RPM modules.

Planning the RPM System Installation, continued

Current Consumption

Current consumption on the communication bus depends on the following factors that contribute to the various voltage levels available to each module on the bus:

- total bus length
- distance of the modules from the controller
- the quantity and type of modules

Configuration Guideline

Although it is difficult to characterize every network bus configuration, Figure 3-1 offers a general guideline. Consult with GE Critical Power Engineering regarding system installations that differ from this general guideline.

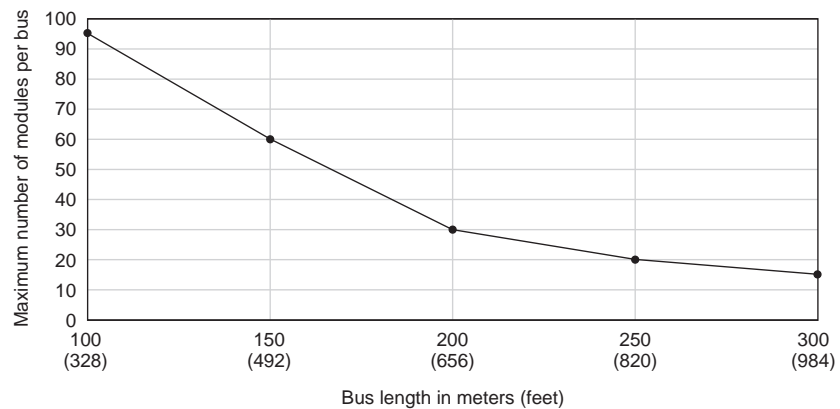

Figure 3-1: Maximum Number of Modules Per Bus Versus Bus Length

Application Specific Configurations

Application-specific configurations of RPM modules are described in the appropriate controller manual.

Galaxy SC Controller 167-790-060

Galaxy Millennium Controller 167-792-180

Note: The Galaxy Vector Controller does not support RPM modules.

4

Safety

Safety Statements

Please read and follow all safety instructions and warnings before installing, maintaining, or repairing the Galaxy SC Controller. Also refer to the peripheral monitoring system product manual for safety statements related to the installation and use of these devices.

The Galaxy SC (including the peripheral monitoring modules) is Listed by Underwriters Laboratories Inc. to the requirements of UL Subject 1801 as a controller for use with DC Power Distribution Centers for Communications Equipment. The Listing is based on the items noted below.

Install only in restricted access areas (dedicated equipment rooms, equipment closets, or the like) in accordance with articles 110-16, 110-17, and 110-18 of the U.S. National Electric Code (NEC), ANSI/NFPA No. 70, and pursuant to applicable local codes.

This equipment is to be used in controlled environments (an area where the humidity is maintained at levels that cannot cause condensation on the equipment, the contaminating dust is controlled, and the steady-state ambient temperature is within the range specified).

This equipment has been evaluated for use in a continuous ambient temperature of up to 50° Celsius.

This equipment must not be installed over combustible surfaces.

This equipment is to be connected to 24vdc or 48vdc systems that are electrically isolated from the ac mains and are reliably earth grounded, or connected to systems where the rectifiers were evaluated to UL1950 and identified as Safety Extra Low Voltage (SELV) outputs.

For installations in the United States, UL Listed compression connectors should be used to terminate UL Listed field-wired conductors where required. For all installations, the appropriate connector should be applied only to the correct size conductor as specified by the connector

manufacturer using only the connector manufacturer's recommended tooling or tooling approved for that connector.

For electrical connections requiring crimp-on lugs, make sure the proper crimping tools and dies are used (information for these connections are provided in the product documentation). Torque electrical connections to the values specified on labels or in the product documentation (T drawings).

For any power wiring, the insulation on field-wired conductors should be rated no less than 90° Celsius. Wire conductor size should be no less than allowed by electrical codes for 60° Celsius wire (regardless of insulation temperature rating used) and based on the ampacity of the associated protection device.

Alarm contacts on TB2 and TB3 are not fused within the controller. Therefore, current limiting protection for these contacts must be provided by external circuits. Maximum ratings for alarm connections are 60vdc and 0.3 amperes. Exceeding these maximum ratings could result in fire or damage to the unit.

Fuse holders, fuses, and termination kits may not be provided with the equipment. Refer to the product documentation for the proper hardware. Use only the parts specified in the equipment documentation (T and J drawings).

The maximum cable sizes or the required cable assemblies for the input/output wiring are noted on the T drawings.

Installing fuses not specified for use in this equipment may result in injury to service personnel or equipment damage. Use only replacement parts listed in this manual and on the equipment drawings.

The shunt circuitry associated to monitoring the input at TB1 (shunt +, shunt -) can be directly connected to "ground" side shunts without requiring an in-line fuse or equivalent current limit device. These leads are not fused on the BJB fuse board. When the Galaxy SC is used with systems where the shunt is located in the hot side of the plant the shunt isolator board in the appropriate adapter kit can be directly connected to the TB1 without fusing. A suitable protective device or in-line fuse rated no more than 1-1/3 amp must be installed in both leads from the shunt to the shunt isolator board.

The input to TB1 (DB/RB) should be wired per applicable local codes or the National Electrical Code. The input wiring should be protected by

a suitable dc rated overcurrent protector. The internal circuits supplied by these inputs are protected on the fuse board inside the controller.

Each output of the peripheral monitor board supplies the peripheral monitoring system modules with current limited Class 2 levels from an inherently limited transformer rated 30 vac max. The typical operating current from each output is less than 0.5 amps (with a maximum of 85 modules attached).

Connectors on the backplane contain communication circuits, current limited signals, and 19 to 30vdc or 36 to 60vdc control signals fused at 1-1/3 amp.

The PCPWR connector on the fuse board is fused at 3 amps. This is intended for supplying dc power to devices located next to the controller.

The BATT PRED connector on the fuse board contains current limited circuitry.

Use only the screws provided for mounting the equipment in a frame or equivalent screws no smaller than No. 12-24 x 5/8. A minimum of 4 screws should be used on each side.

Grounding/bonding for the equipment can be provided through the mounting brackets. In this case, make sure the frame is suitably grounded. There is also a place provided on the equipment for the connection of a grounding conductor.

This controller uses a replaceable lithium battery:

WARNING

Danger of explosion or fire if lithium battery is incorrectly replaced. Replace only with Panasonic BR2032 or an equivalent recommended by the manufacturer. Spare batteries may be ordered per the product documentation. Lithium batteries may be regulated wastes (due to reactivity) when disposed of. Always discard used batteries according to applicable local, state, and federal regulations.

Notice:

The battery manufacturer, Panasonic, has provided the following information regarding its product. Caution: Risk of fire, explosion, and burns. Do not recharge, disassemble, heat above 100° C (212° F), or incinerate. Dispose of used batteries promptly. Keep away from children.

Precautions

Install, service, and operate equipment only by professional, skilled and qualified personnel who have the necessary knowledge and practical experience with electrical equipment and who understand the hazards that can arise when working on this type of equipment.

Disconnect batteries from outputs and/or follow safety procedures while working on equipment. Batteries may be connected in parallel with the output of the rectifiers. Turning off the rectifiers will not necessarily remove power from the bus.

Do not disconnect permanent bonding connections unless all power inputs are disconnected.

Verify that equipment is properly safety earth grounded before connecting power. High leakage currents may be possible.

Exercise care and follow all safety warnings and practices when servicing this equipment. Hazardous energy and voltages are present in the unit and on the interface cables that can shock or cause serious injury. When equipped with ringer modules, hazardous voltages will be present on the ringer output connectors.

Use the following precautions in addition to proper job training and safety procedures:

- Use only properly insulated tools.
- Remove all metallic objects (key chains, glasses, rings, watches, or other jewelry).
- Follow Lock Out Tag Out (LOTO) procedures: customer specified, site specific, or general as appropriate.
- Disconnect all power input before servicing the equipment. Check for multiple power inputs.
- Wear safety glasses.
- Follow Personal Protective Equipment requirements: customer specified, site specific, or general as appropriate.
- Test circuits before touching.

- Be aware of potential hazards before servicing equipment.
- Identify exposed hazardous electrical potentials on connectors, wiring, etc.
- Avoid contacting circuits when removing or replacing covers;.
- Use a personal ESD strap when accessing or removing electronic components.
- Follow procedures for working at heights more than 4ft above the floor: customer specified, site specific, or general as appropriate.

Personnel with electronic medical devices need to be aware that proximity to DC power and distribution systems, including batteries and cables, typically found in telecommunications utility rooms, can affect medical electronic devices, such as pacemakers. Effects decrease with distance.

5 *Installation*

Installation Preparations

Installation Materials

- 1 set of standard installer's tools (standard size screwdrivers)
- Universal digital multimeter (Fluke 8060A or equivalent)
- Jeweler's screwdriver
- Crimp tool (22-16 gauge)
- Ballpoint pen

Safety

- When working in a powered plant, USE EXTREME CARE to avoid contacting exposed terminals and bus bars.
- Make sure the plant is properly grounded according to local building codes before proceeding.
- Label all cables associated with the change before beginning installation.
- Read the Safety section of this product manual carefully before installing the RPM modules. Follow all safety instructions and warnings during the installation process.
- Observe antistatic precautions during the installation procedure.
- Remove all metal jewelry.

DANGER

Powered circuits may be connected to the RPM modules. Use extreme caution!

Replacements or Additions to an RPM System

Monitoring/ Control Units

If necessary, monitoring/control units may be disconnected from the connection unit while it is powered. As long as the communications bus wires are not disconnected or short-circuited, the controller will continue to monitor the other modules on the bus.

Note that all data collection (statistics, history, trend, etc.) associated with a disconnected module is stopped. After the module is reconnected and initialization is complete, the module is capable of providing monitoring information.

Connection Units or Bus

When replacing a connection unit or rearranging a bus, the power may be temporarily interrupted to all or part of the Remote Peripheral Monitoring System. When communications are restored, some or all modules on the communications bus will require time to re-initialize.

New Module Added to End of a Bus

If a new module is being added to the end of a bus, follow the procedures for the controller power-down sequence. Connect the new connection unit as shown in Figure 5-5. Remove the terminating resistor from the previously last connection unit and place it in the newly added connection unit. Before attaching the new RPM module, set its address to a non-used number. Attach the module to the connection unit. Follow instructions for the Controller power-up sequence.

Mounting the Modules

Location

Individual RPM modules can be secured to virtually any location near the equipment to be monitored. The connection unit allows front access to all termination points.

Note: Make sure the mounting location allows easy viewing of the green status LED on the module.

Optional Panel or Brackets

RPMs can be installed on a mounting panel or bracket. The J85501G-1 Lists K1, K2, and K3 panel and brackets, and the GPS panel (comcode 848285854) are illustrated in Figure 5-1. Comcoded mounting panels 848412367 and 108984477 are similar to List K1 but are designed for standard 23-inch frames. Refer to Section 2 for more information.

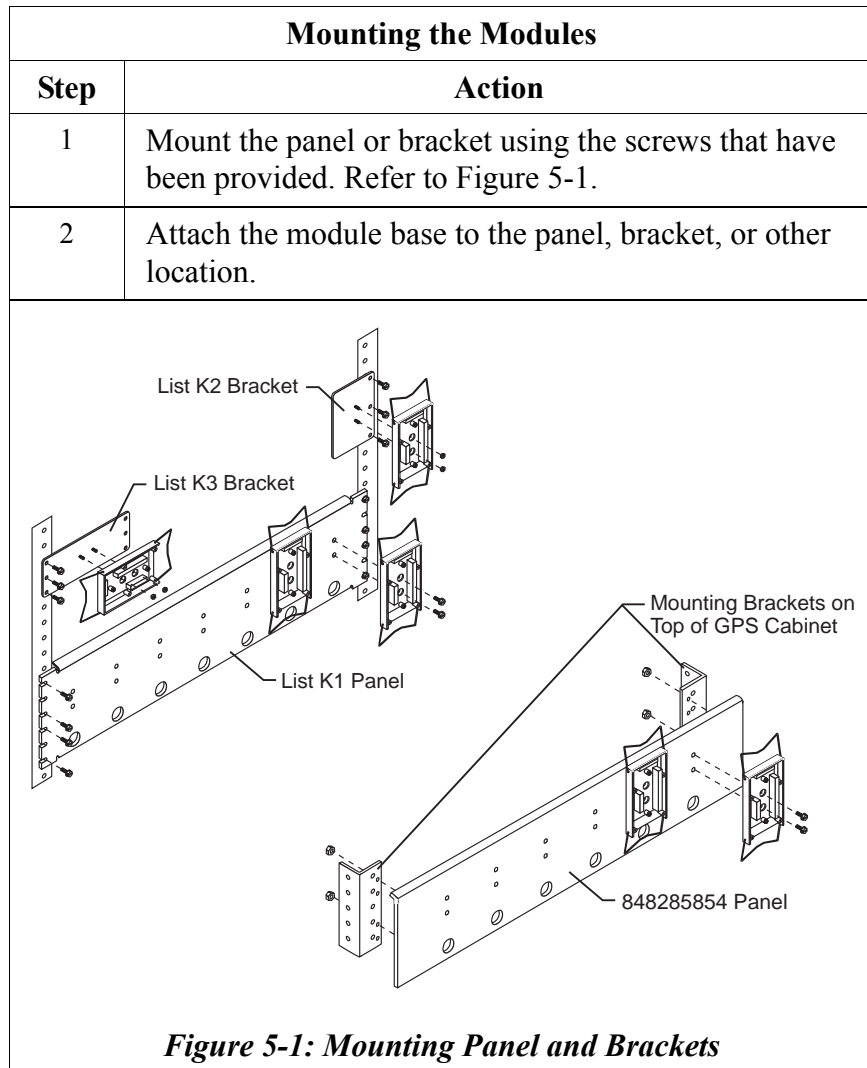

Making TB101 and TB102 Connections

TB101

The connection for the monitoring/control signals is made between terminal block TB101 on the RPM module and the equipment being monitored.

The connection units are wired as follows:

- For Voltage, Shunt, Binary, and Transducer Modules, use TB101 to connect the six voltage channel inputs and one temperature channel input.
- For the Temperature Module, use TB101 to connect up to seven thermistors or thermal probes to different measuring points.
- For the Control Relay Module, use TB101 to connect up to three control points. The maximum relay contact voltage is 110 Vdc and maximum current is 0.3 Adc. Wiring to TB101 depends on the voltage, current, local building codes, and various other characteristics of the controlled point.

TB102

The connection for communications input/output is made between terminal block TB102 on the RPM module and the controller interface circuit pack.

Making TB101 and TB102 Connections, continued

Making TB101 and TB102 Connections	
Step	Action
1	<p>Connect wiring from monitored equipment to TB101 on the RPM module connection unit, as shown in Figures 5-2, 5-3, and 5-4.</p> <p>Note: Except for the temperature input, maintain correct polarity.</p>
2	<p>Using shielded twisted pair cable (comcode 407377704), wire the input/output communications bus from TB102 to the bus controller circuit pack. If connecting more than one RPM, daisy chain the modules, as shown in Figure 5-5.</p> <p>Note: Polarity is not essential for the input/output communications bus wiring (except for shield).</p>
3	<p>Using the circuit pack installation guide corresponding to the Galaxy controller, install the RPM bus controller circuit pack.</p>
4	<p>Before terminating the bus wire at the controller, run the wire three times through one of the supplied inductor beads (406712968). See Figure 5-5.</p> <p>Note: Use one inductor bead for each bus.</p>
5	<p>Route the wires connected to the module through the open-faced bottom of the connection unit. Place a cable tie or waxed cord through the opening at the bottom of the connection unit and around the connected wires for strain relief.</p>
<i>Continued on next page.</i>	

Making TB101 and TB102 Connections, continued

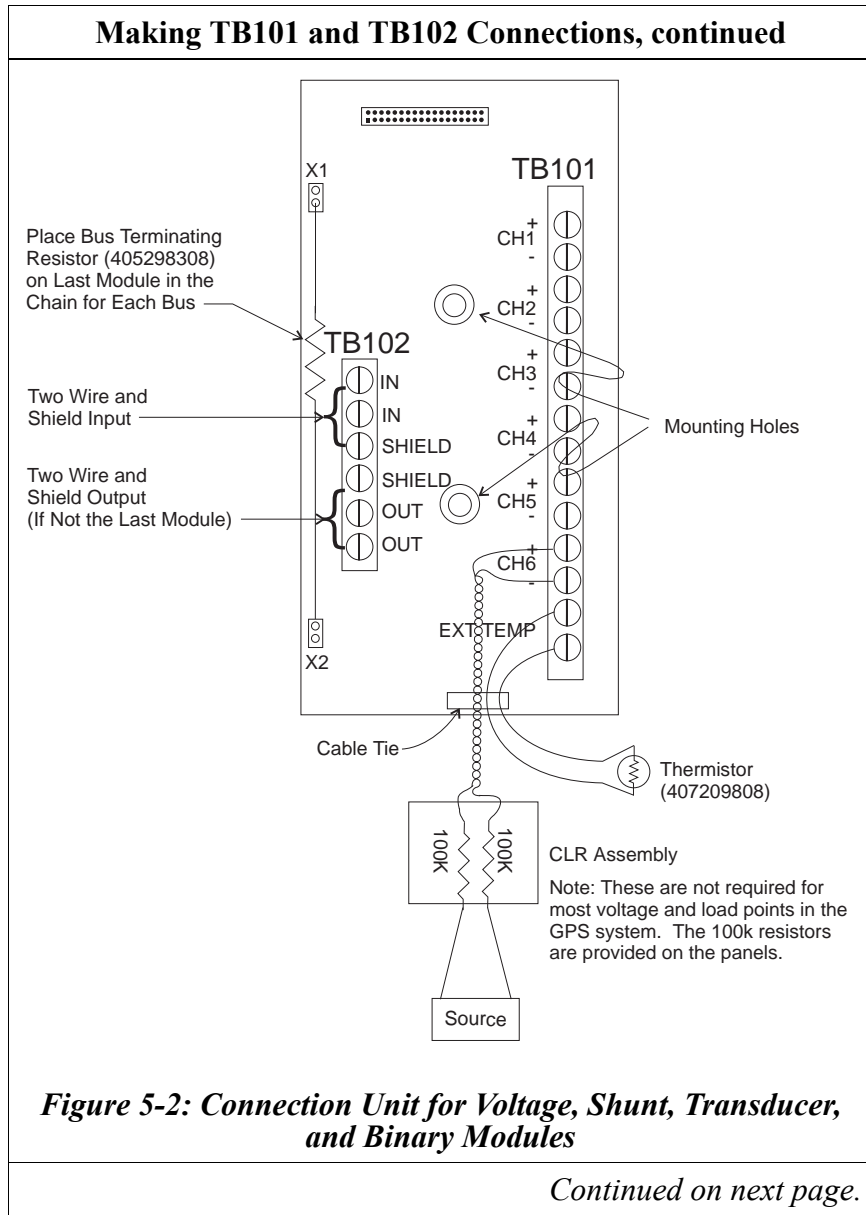

Making TB101 and TB102 Connections, continued

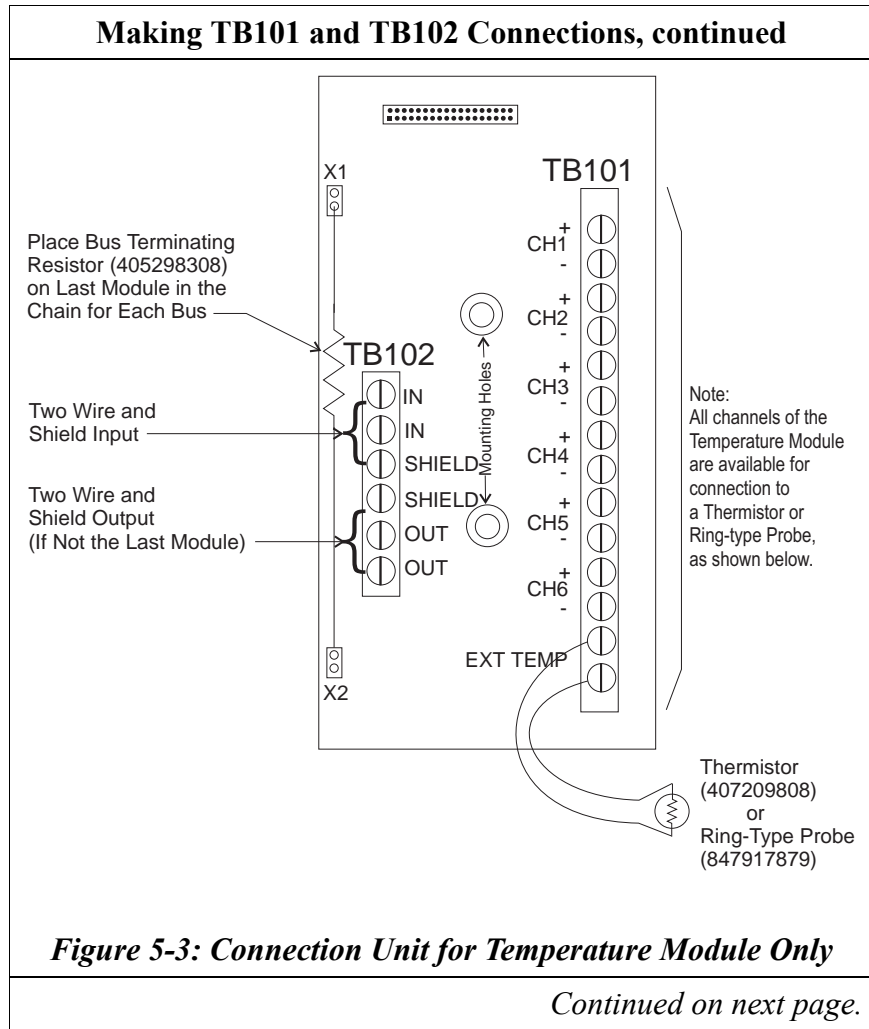

Making TB101 and TB102 Connections, continued

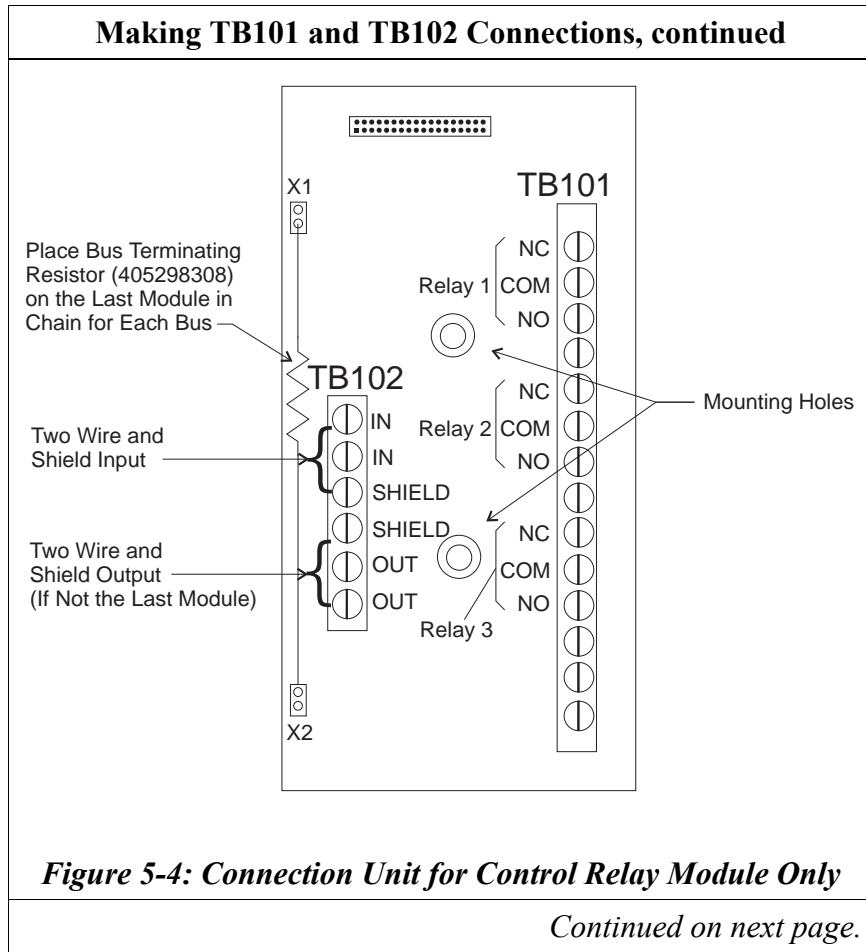
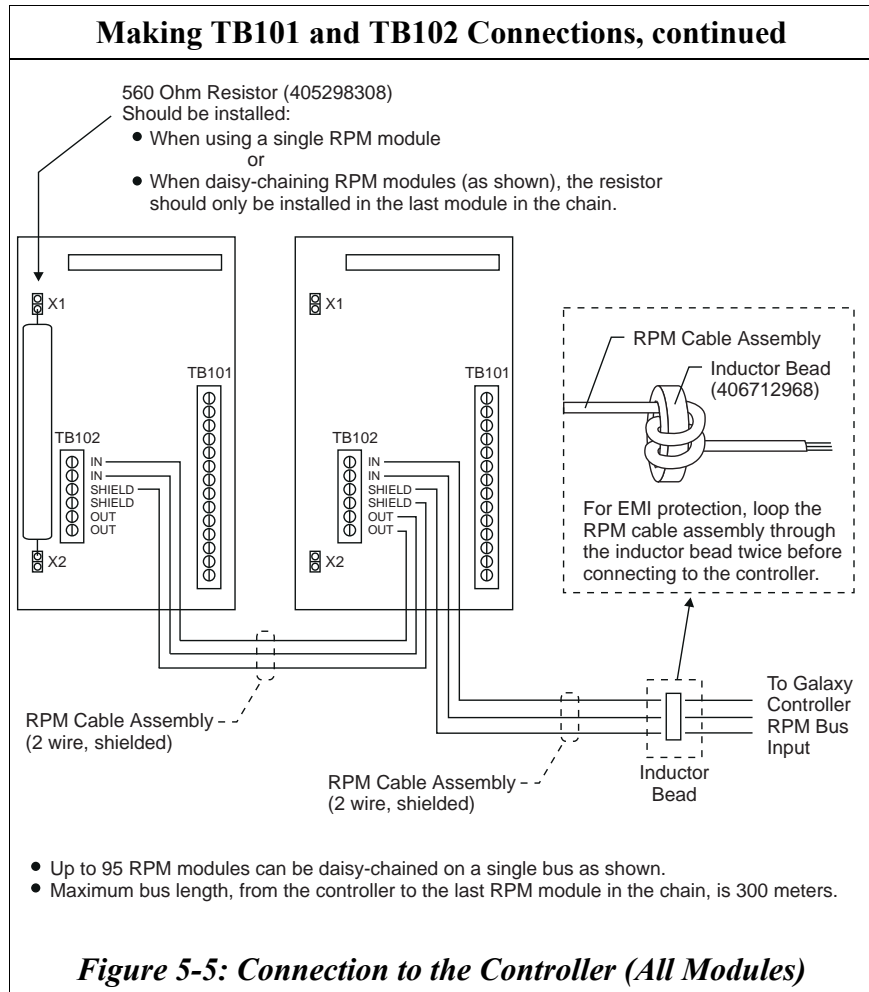

Figure 5-4: Connection Unit for Control Relay Module Only

Continued on next page.

Making TB101 and TB102 Connections, continued



Terminating the Final Module

Terminating the Final Module	
Step	Action
1	<p>Place a terminating resistor (560 ohm, 10 watt; comcode 405298308) in the socket of the final bus module for each of the three buses. See Figure 5-5.</p> <p>Note: If a bus is not used, install a terminating resistor on the controller interface for the unused bus.</p>
2	<p>To verify that no shorts exist between the two cable connections (blue or white) on the final bus module, measure the resistance across the blue and white wires of the module containing the terminating resistor. The resistance measurement should be in the range of 560-600 ohms.</p> <p>If the resistance measurement <i>is</i> in the range of 560-600 ohms, proceed to “Assigning Module Addresses.”</p> <p>If the resistance measurement <i>is not</i> in the range of 560-600 ohms, verify that the 560 ohm, 10 watt resistor has been installed in the last module. If not, install it now and repeat the measurement. If the measurement is not in the 560-600 ohm range, proceed to Step 3.</p>
3	<ol style="list-style-type: none"> a. Check for cracks in the 560 ohm, 10 watt resistor. If cracks exist, replace the resistor. Repeat Step 2. b. Check for loose connections of the white and blue wires at each module and the controller. If necessary, tighten connections. Repeat Step 2.

Assigning Module Addresses

Using Unique Addresses

Each module requires a unique address for proper communication between the module and controller. All addresses are valid except 00. **The Galaxy controller will not recognize a module with a 00 address.**

SW1 and SW2

The unique address is set with two switches (SW1 - Hi and SW2 - Low) located on the Remote Peripheral Monitoring module. See Figure 5-6.

Hexadecimal Numbers and Letters

The switch display numbers/letters are in hexadecimal.

For example: SW1 - Hi = D
 SW2 - Low = 8
 The HEX address is D8.

Note: Appendix A provides a decimal-to-hexadecimal conversion table.

Assigning Module Addresses	
Step	Action
1	Using a jeweler's screwdriver, set the address on each module. (See Figure 5-6.)

The diagram shows a rectangular module with a header connector at the top. Below the connector are two rows of three small rectangular components. In the lower-left area, there are two rotary switches. The top switch is labeled 'SW1 HI' and the bottom switch is labeled 'SW2 LOW'. Both switches have a circular dial with hexadecimal characters: 0, 1, 2, 3, 4, 5, 6, 7, 8, 9, A, B, C, D, E, F. A large circular target symbol with a crosshair is located to the right of the switches. There are also two larger rectangular components on the right side of the module.

Figure 5-6: Switches for Setting Hexadecimal Addresses

Installing Current Limiting Resistors

Voltage, Shunt, and Transducer Modules

Installing Current Limiting Resistors for Voltage, Transducer, and Shunt Modules

Step	Action
1	<p>Place a 100K-ohm current limiting resistor (CLR) assembly near the monitoring point. Refer to Figures 5-7 and 5-8 for wiring examples.</p> <p>Note: Use CLR Comcode 847540424 for Voltage and Transducer Modules and CLR Comcode 847568920 for the Shunt Module.</p>

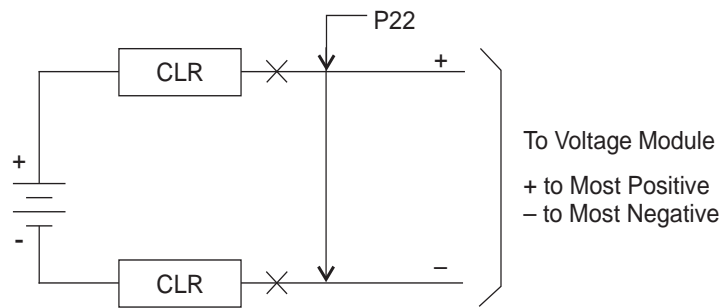

Scale Factor = 1 for Positive Polarity Plant
 Scale Factor = -1 for Negative Polarity Plant

Figure 5-7: DC Plant Voltage Monitoring

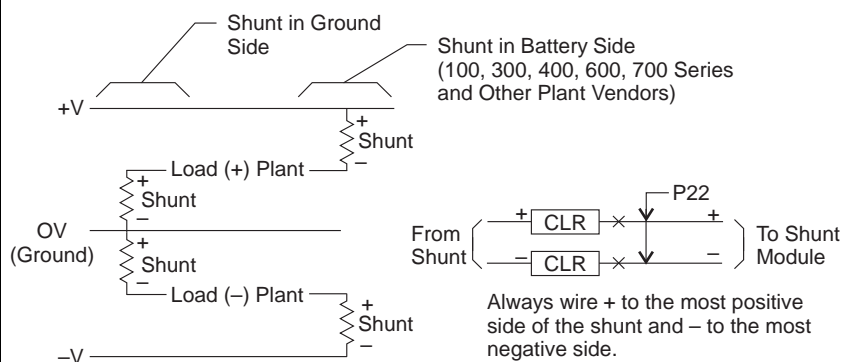

Figure 5-8: DC Plant Load Monitoring

Installing Current Limiting Resistors, continued

Binary Module

Installing Current Limiting Resistors for a Binary Module			
Step	Action		
1	For measuring dry relay contacts (isolated contacts without voltages present) connect directly to the Binary RPM module channel inputs. Do not utilize the 100K ohm current limiting resistor assembly.		
<p style="text-align: center;"> $V < 1.9 \text{ VDC} = \text{"0" or "Closed" State}$ $V > 3.1 \text{ VDC} = \text{"1" or "Open" State}$ </p> <p style="text-align: center;">Figure 5-9: Functional Schematic for One Channel of a 222A Binary Module</p>			
<table border="1" style="width: 100%; border-collapse: collapse;"> <tr> <td style="width: 50%; padding: 5px;"> If the equipment alarm contact closes for an alarm condition, set the associated User-Defined Channel program line to activate when: BinCh = 0 or BinCh = Closed or Not BinCh </td> <td style="width: 50%; padding: 5px;"> If the equipment alarm contact opens for an alarm condition, set the associated User-Defined Channel program line to activate when: BinCh = 1 or BinCh = Open or BinCh </td> </tr> </table> <p style="text-align: center;">Figure 5-10: Isolated Alarm Contact Monitoring Using a 222A Binary Module</p> <p style="text-align: right;"><i>Continued on next page.</i></p>		If the equipment alarm contact closes for an alarm condition, set the associated User-Defined Channel program line to activate when: BinCh = 0 or BinCh = Closed or Not BinCh	If the equipment alarm contact opens for an alarm condition, set the associated User-Defined Channel program line to activate when: BinCh = 1 or BinCh = Open or BinCh
If the equipment alarm contact closes for an alarm condition, set the associated User-Defined Channel program line to activate when: BinCh = 0 or BinCh = Closed or Not BinCh	If the equipment alarm contact opens for an alarm condition, set the associated User-Defined Channel program line to activate when: BinCh = 1 or BinCh = Open or BinCh		

Installing Current Limiting Resistors, continued

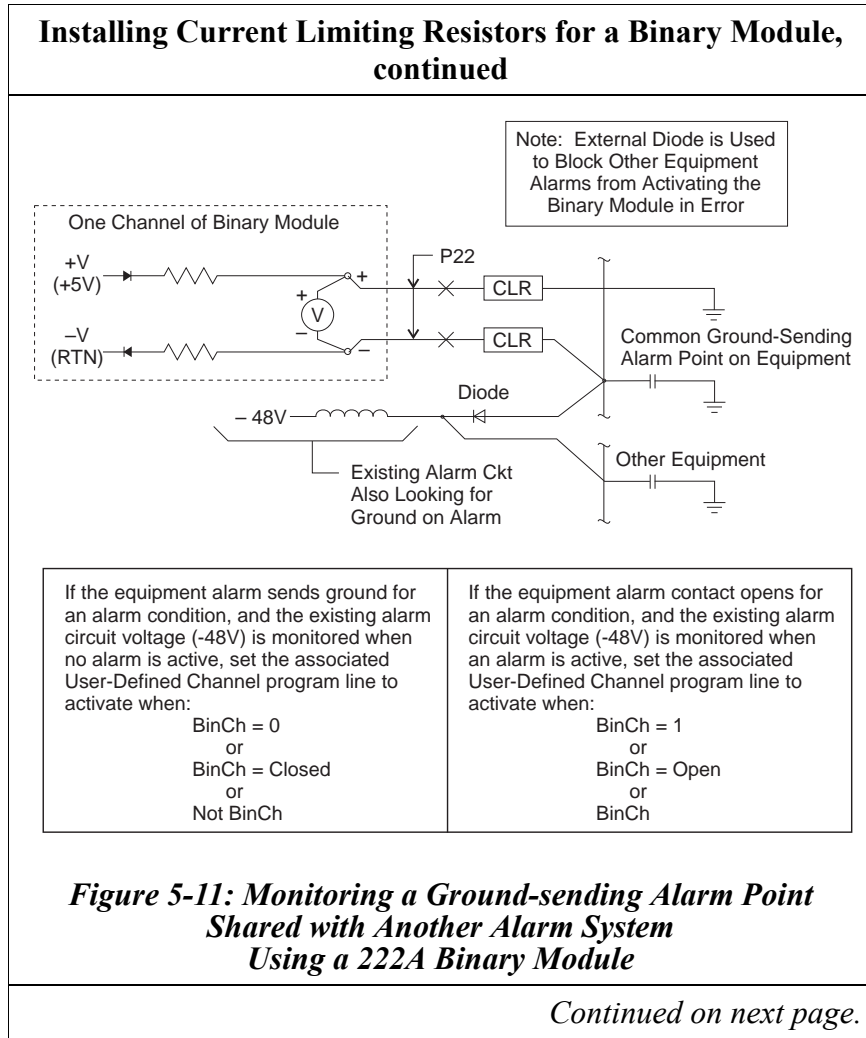

Installing Current Limiting Resistors, continued

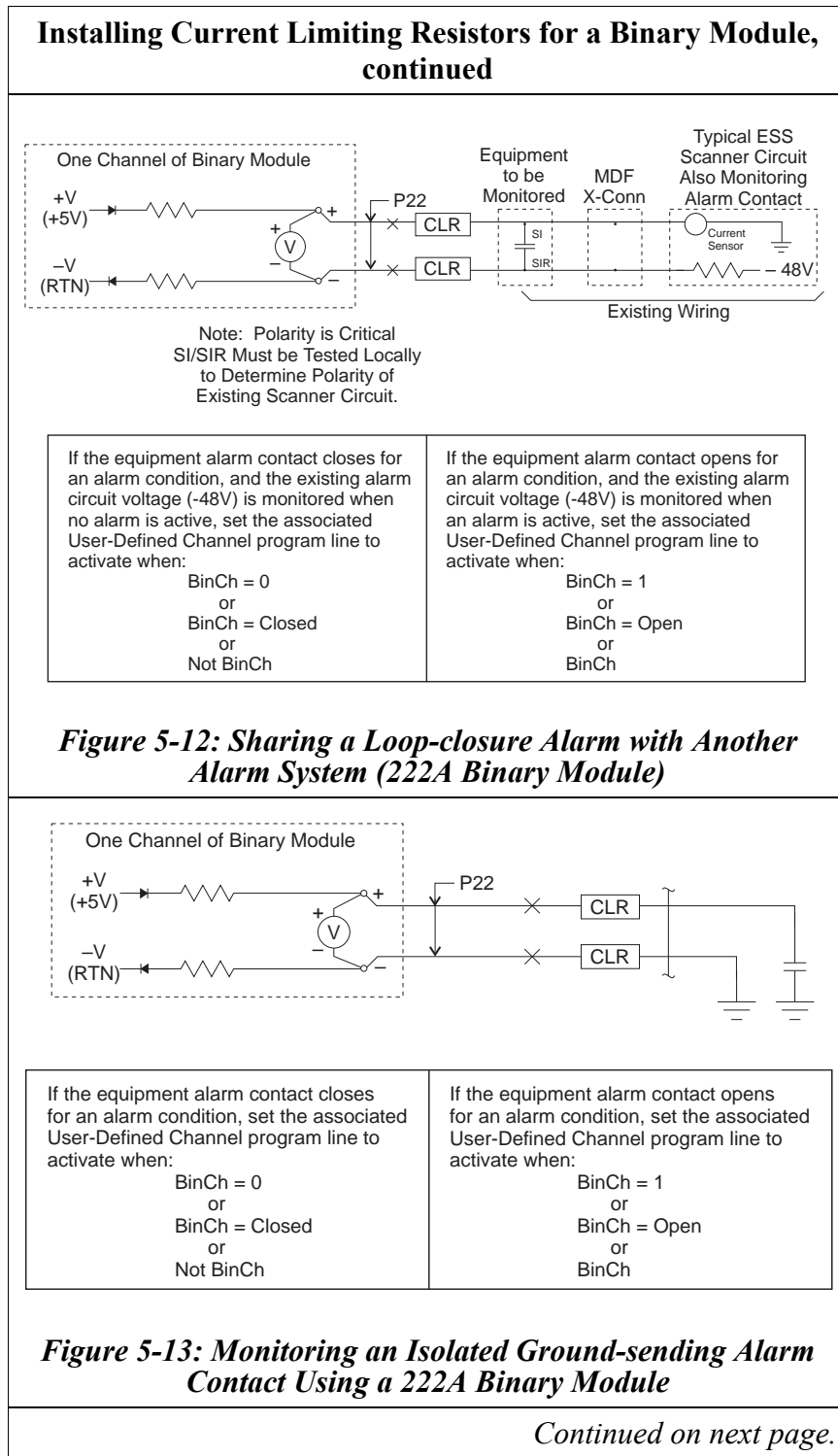

Installing Current Limiting Resistors, continued

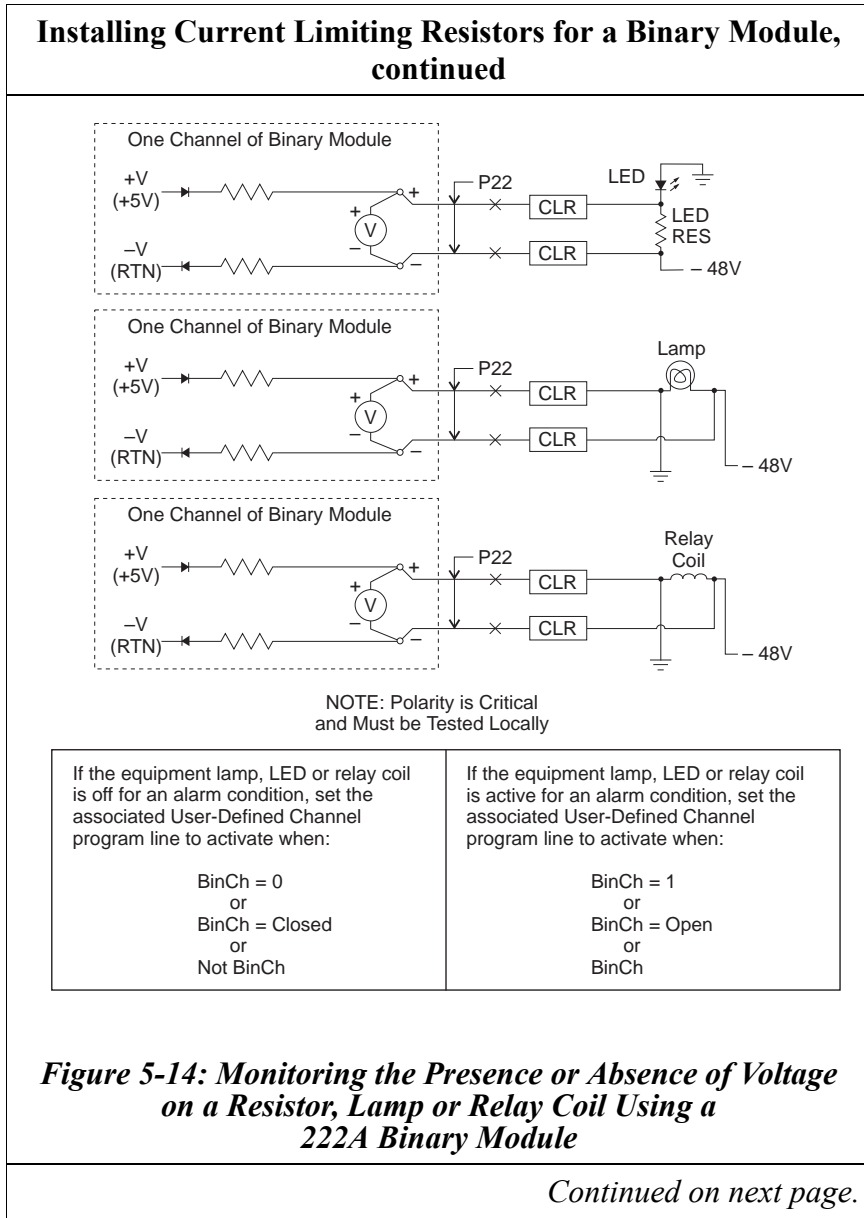

Installing Current Limiting Resistors, continued

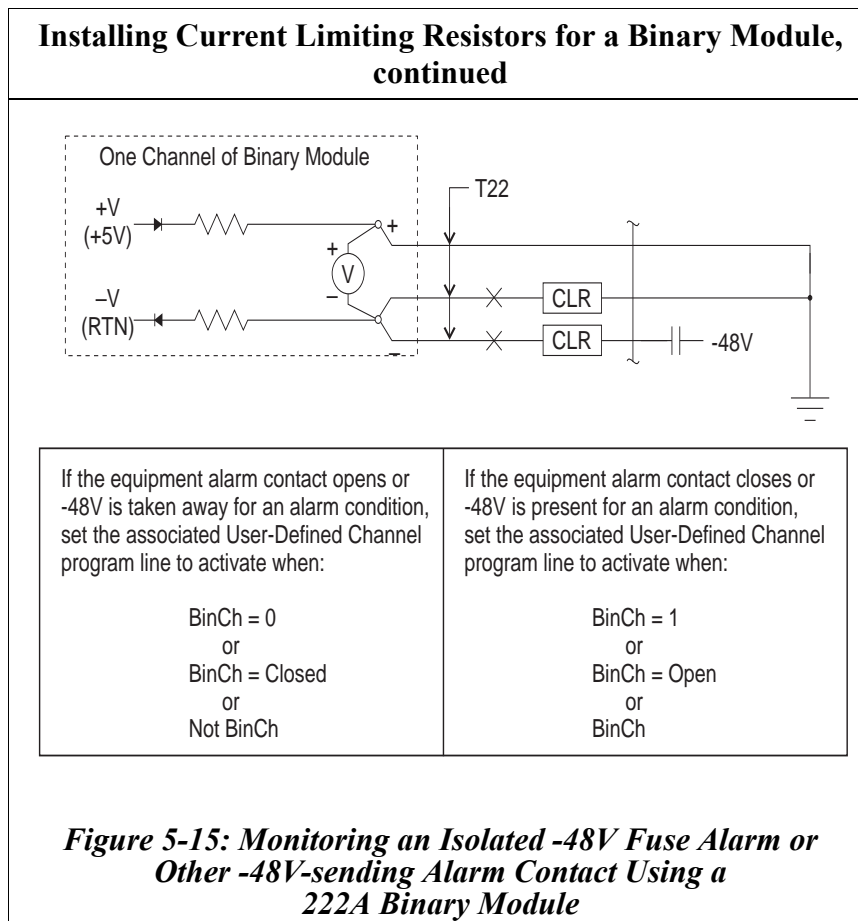

Making the Controller Interface

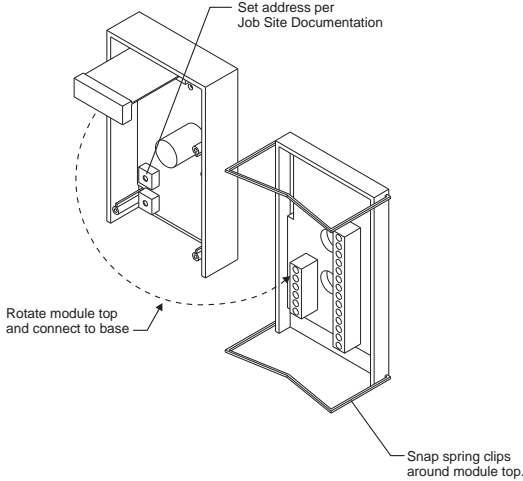
Making the Controller Interface	
1	Secure each module to the connection unit with the two clips provided. Refer to Figure 5-16.
 <p>The diagram illustrates the assembly of the RPM module top and base. It shows two views: a perspective view of the module top being rotated into the base, and a top-down view of the base with the module top already attached. Labels indicate: 'Set address per Job Site Documentation' pointing to a small component on the top; 'Rotate module top and connect to base' with a dashed arrow indicating the rotation; and 'Snap spring clips around module top.' pointing to the clips on the base.</p>	
Figure 5-16: RPM Module Top and Base	
2	Write the connected equipment description and module address on the label on the front of the module.

Initialization Sequence

Rapid Cycling of the Green LED

Upon connection to a controller, the RPM modules will begin the initialization sequence. This is characterized by a rapid cycling of the Green LED (approximately four cycles per second) on the front of the module.

Continuous Illumination of the Green LED

The process of module initialization may require various time periods depending on the total number of modules on the communications bus. Once initialization has been completed, the Green LED should stay continuously illuminated except for short periods when the module is communicating with the controller.

Slow Cycling of the Green LED

A slow cycling of the Green LED (approximately one cycle per second) will occur if the address switches of the module are set to 00 (invalid address) because the controller will not recognize this address. If the module address is set to 00, remove the module from the bus, change its address, and re-attach it to the bus.

Warning

<p>Before changing the address, the module must be electrically disconnected from the bus. The module should not be re-attached for at least five seconds following an address change. This allows the storage capacitors in the module to discharge.</p>

6 Troubleshooting

Table 6-A: Troubleshooting

Symptom	Possible Cause(s)	Recommended Procedure(s)
Green LED flashes steady (approx. 1 second pulse)	Invalid Address - module is not initialized	Verify module has unique address. Module cannot use address 00.
Green LED stays on continuously (never flashes)	Module Failure - component failure on module base or module cover	1. Run diagnostics on controller. 2. Replace module.
		1. Create a user-defined event for each installed module to identify which module is failing. 2. Replace module that failed.
Green LED stays off	Module not connected to bus	1. Verify wiring to interconnect module.
	Module failure	2. Replace module.
Measurement out of range	Excessive or reverse voltage polarity to channel input	Verify that input voltage is less than the maximum measurement voltage. Verify channel input polarity.
Module type conflict	Module type does not match controller software configuration	Replace module with correct type or unlock and change software configuration (see controller manual).

Appendix *Decimal/Hexadecimal Conversion*

A Table

Table A-1: Decimal/Hexadecimal Conversion

Dec	Hex	Dec	Hex	Dec	Hex	Dec	Hex	Dec	Hex	Dec	Hex
Invalid	00	43	2B	86	56	129	81	172	AC	215	D7
1	01	44	2C	87	57	130	82	173	AD	216	D8
2	02	45	2D	88	58	131	83	174	AE	217	D9
3	03	46	2E	89	59	132	84	175	AF	218	DA
4	04	47	2F	90	5A	133	85	176	B0	219	DB
5	05	48	30	91	5B	134	86	177	B1	220	DC
6	06	49	31	92	5C	135	87	178	B2	221	DD
7	07	50	32	93	5D	136	88	179	B3	222	DE
8	08	51	33	94	5E	137	89	180	B4	223	DF
9	09	52	34	95	5F	138	8A	181	B5	224	E0
10	0A	53	35	96	60	139	8B	182	B6	225	E1
11	0B	54	36	97	61	140	8C	183	B7	226	E2
12	0C	55	37	98	62	141	8D	184	B8	227	E3
13	0D	56	38	99	63	142	8E	185	B9	228	E4
14	0E	57	39	100	64	143	8F	186	BA	229	E5
15	0F	58	3A	101	65	144	90	187	BB	230	E6
16	10	59	3B	102	66	145	91	188	BC	231	E7
17	11	60	3C	103	67	146	92	189	BD	232	E8
18	12	61	3D	104	68	147	93	190	BE	233	E9
19	13	62	3E	105	69	148	94	191	BF	234	EA
20	14	63	3F	106	6A	149	95	192	C0	235	EB
21	15	64	40	107	6B	150	96	193	C1	236	EC
22	16	65	41	108	6C	151	97	194	C2	237	ED
23	17	66	42	109	6D	152	98	195	C3	238	EE
24	18	67	43	110	6E	153	99	196	C4	239	EF
25	19	68	44	111	6F	154	9A	197	C5	240	F0
26	1A	69	45	112	70	155	9B	198	C6	241	F1
27	1B	70	46	113	71	156	9C	199	C7	242	F2
28	1C	71	47	114	72	157	9D	200	C8	243	F3
29	1D	72	48	115	73	158	9E	201	C9	244	F4
30	1E	73	49	116	74	159	9F	202	CA	245	F5
31	1F	74	4A	117	75	160	A0	203	CB	246	F6
32	20	75	4B	118	76	161	A1	204	CC	247	F7
33	21	76	4C	119	77	162	A2	205	CD	248	F8
34	22	77	4D	120	78	163	A3	206	CE	249	F9
35	23	78	4E	121	79	164	A4	207	CF	250	FA
36	24	79	4F	122	7A	165	A5	208	D0	251	FB
37	25	80	50	123	7B	166	A6	209	D1	252	FC
38	26	81	51	124	7C	167	A7	210	D2	253	FD
39	27	82	52	125	7D	168	A8	211	D3	254	FE
40	28	83	53	126	7E	169	A9	212	D4	255	FF
41	29	84	54	127	7F	170	AA	213	D5		
42	2A	85	55	128	80	171	AB	214	D6		

Appendix AC Interface Units

B

Applications

Functions of the Units

AC interface units are available to enable the Galaxy controller to perform a variety of ac monitoring applications. These ac interface units convert ac signals to low voltage dc outputs that can be transmitted to monitoring systems. These interface units provide accurate monitoring of ac voltage, current, and frequency of:

- Commercial ac load circuits
- Engine/generator outputs
- UPS outputs
- Inverter outputs
- Other ac monitoring

Programming Examples

The Galaxy controller can be programmed to provide accurate ac reporting. Examples are:

- UPS output voltage too high/low
- Inverter output voltage too high/low
- Commercial ac failure
- Transfer to engine/generator
- Engine/generator voltage too high/low
- Monitor engine/generator frequency
- High/low ac current alarms
- Output frequency too high/low

Available Units

Overview

AC interface units are available to monitor ac voltage, ac current, or ac frequency. Each unit may be ordered separately, or a combination of one voltage and one current unit may be ordered as a cost-effective voltage-current unit in a single metal housing.

The Voltage Interface Unit, Current Interface Unit, and Frequency Interface Unit are designed to provide a simple-to-install, pre-packaged solution for ac monitoring applications.

The Voltage and Current Interface Unit is designed to provide a flexible solution for applications that require a combination of voltage and current monitoring.

Voltage Interface Unit

The Voltage Interface Unit provides accurate single or three phase line-line (delta configuration) or line-neutral (wye configuration) RMS ac voltage measurements.

Refer to the AC Voltage Interface Unit for Galaxy Controller product manual, Select Code 167-792-104, for more information.

Current Interface Unit

The Current Interface Unit provides accurate ac current measurements for up to three circuits. The current transformers selected determine the range for accurate current measurement. The range may be 0-50A, 0-100A, 0-300A, 0-600A, or 0-2000A. Solid-core or split-core transformers may be used. Use of a split-core transformer allows installation around the current carrying conductor without interrupting service. Solid-core transformers are a less expensive solution, but may require higher installation costs, and require interruption of service for installation. Solid-core transformers are ideal for new ac circuit installations and are more accurate than split-core.

Refer to the AC Current Interface Unit for Galaxy Controller product manual, Select Code 167-792-103, for more information.

Available Units, continued

Frequency Interface Unit

The Frequency Interface Unit provides accurate frequency monitoring for 50, 60, and 400 Hz center frequencies.

Refer to the AC Frequency Interface Unit for Galaxy Controller product manual, Select Code 167-792-102, for more information.

Voltage/Current Interface Unit

The Voltage/current Interface Unit provides accurate three phase (line-line or line-neutral) voltage and three phase current monitoring in a single enclosure.

Refer to the AC Voltage/Current Interface Unit for Galaxy Controller product manual, Select Code 167-792-105, for more information.

Installation

Introduction

Complete instructions for installing, operating and maintaining the modules are packed with the units themselves. This section provides guidelines to help prepare for installation.

Required Components

The following components are required for ac measurements with the Galaxy controller:

- Independent (Basic) Controller
- Intelligent Option Card
- Remote Peripheral Monitoring Option Card
- 0-3V Remote Peripheral Module(s)

Mounting

The units can be wall mounted on any flat, smooth surface using the mounting holes provided in the rear of the units. Suitable fasteners should be used when mounting on masonry or drywall.

Wiring

Electrical knockouts are provided on the top and bottom of the ac units for conduit connections. The units have separate high and low voltage terminal block connectors for connecting the units to the measurement point(s) and to the remote monitoring module channel inputs. Wiring from the units to the measurement point(s) should be fused (capable of being disconnected when performing maintenance on the units) at the measurement point.

Ordering Information

Ordering the Units Please refer to your Product Guide or contact your GE Critical Power Account Representative.

Receiving the Units The units are delivered with the measurement modules and current limiting resistors factory mounted and pre-wired, which greatly simplifies the installation process. Before you begin, read and review all safety rules and procedures.

