

ReliaGear® lighting panelboards

Mounting hardware kit for A2, XT1 and XT4 circuit breakers

Introduction

These instructions describe the installation of a three-pole A2 or XT1 or XT4 circuit breaker using the kit provided into a ReliaGear lighting panelboard.

The catalog number for A2 three-pole mounting kit is ASPA23P (Table 1). The catalog number for XT1 three-pole mounting kit is ASPXT13P (Table 2). The catalog number for XT4 three-pole mounting kit is ASPXT43P (Table 3).

Table 1. Parts list for A2 three-phase breaker mounting kit, catalog number ASPA23P.

Item #	Description	Part #	Qty.
1	A2 Z-Strap 225A	30014873564P10	3
2	Mounting Bracket, A2	30014876551P19	1
3	Bracket Insulation, A2	30014877432P20	1
4	M4x55 Hex Socket Head Cap Screw	L15P12055B70	2
5	M8 Narrow Flat Washer	L400P10B33	3
6	M8 Helical Spring Lock Washer	L401P27B70	3
7	M8x25 Hex Socket Button Head Screw	L16P17025B70	3
8	Thread Rolling Screw and Washer, #1/4-20 x 7/8"	315A7034P3	3
9	Screw, #10-32 x 1/4"	N722P16004B6	2
10	Phase-Barrier 80mm 2 pcs	1SDA066192R1	1
11	A2 Low Terminal Cover	1SDA066183R1	1

Installation

Use the following procedure to install an A2, XT1 and XT4 breaker mounting kit into a ReliaGear lighting panelboard. Call-out numbers in the illustrations and numbers in brackets in the text refer to the Item Numbers in Tables 1, 2 and 3. Installation of an A2 breaker mounting kit is illustrated in Figures 1 and 2. Installation of a XT1 breaker mounting kit is illustrated in Figures 3 and 4. Installation of a XT4 breaker mounting kit is illustrated in Figures 5 and 6.



WARNING: Danger of electrical shock or injury. Turn OFF power ahead of the panelboard before working inside the equipment or removing any component. Do not remove circuit protective devices or any other component until the power is turned OFF.

A2 mounting kit

- Remove the kit from its packaging and verify that all parts are present, as given in the packing list.
- Create circuit breaker subassembly following these steps:
 - Wrap the bracket insulation [3] around the mounting bracket [2].
 - Align breaker mounting holes with the mounting bracket and insulation assembly.
 - Fasten the breaker to the mounting bracket and insulation assembly by using the two M4x55 hex socket screws cap [4] to 9-11 lb-in.
 - Align Z-straps [1] over the breaker terminals on the "ON" side and place the flat [5] and spring [6] washers.
 - Fasten the Z-strap [1] with the M8x25 screws [7] to the breaker terminal to 64-78 lb-in.
 - Place the 80mm phase barriers [10] by sliding them down as indicated by the arrow.
- Drop the breaker subassembly. Align the Z-strap on the breaker assembly over the strap inside the plastic base. Hand-tighten the thread-rolling screw [8] to locate the breaker assembly. On the other side, align the mounting bracket on the breaker assembly over the interior rail holes. Once aligned tighten the two #10-32 screws [9] to 27-36 lb-in. Tighten the three thread-rolling screws [8] to 42 lb-in.
- Place low terminal cover [11] on the "OFF" side of the breaker.

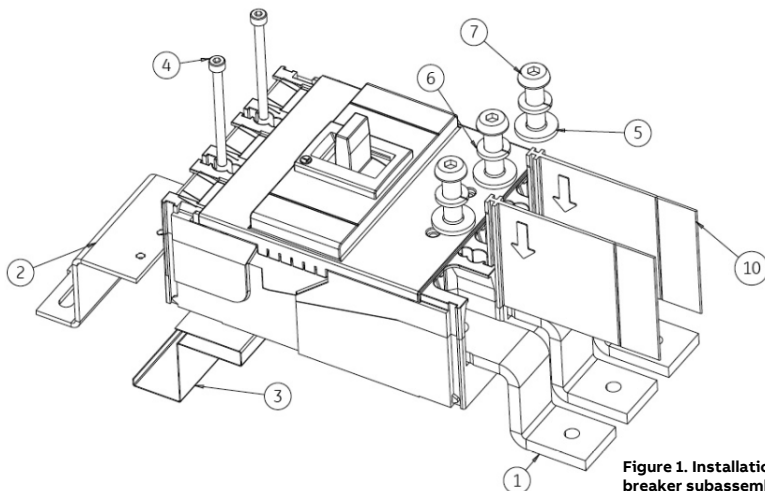

Figure 1. Installation of A2 three-phase, three-pole breaker subassembly.

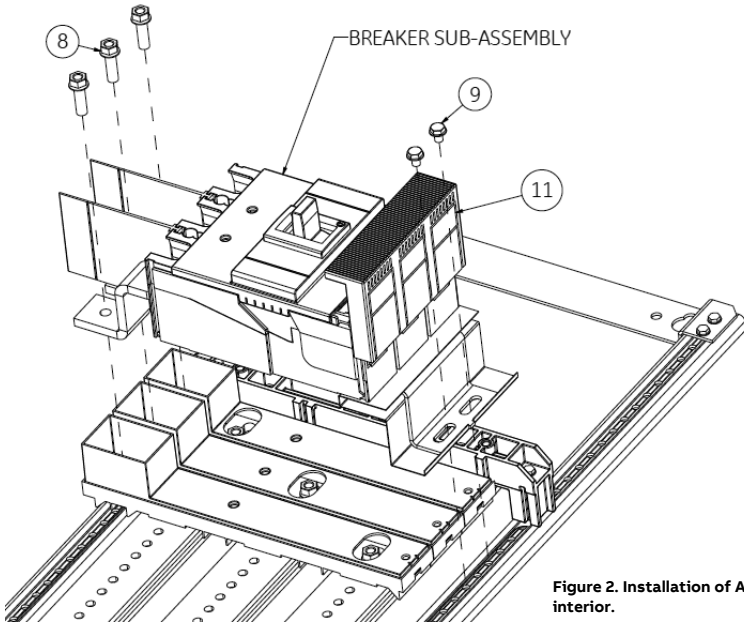

Figure 2. Installation of ASPA23P on a lighting panel interior.

Table 2. Parts list for XT1 three-phase breaker mounting kit, catalog number ASPXT13P.

Item #	Description	Part #	Qty.
2	Mounting Bracket, XT1	30014876551P1	1
3	Bracket Insulation, XT1	30014877432P1	1
4	M4 Socket Head Cap Screw	L15EP12065B70	1
5	Narrow Flat Washer, #10	N402P9B6	3
6	Lock Washer, #10	N405P39B6	3
7	Hex Head Screw, #10-24 x 3/8"	N170P17006B70	3
9	Screw, #10-32 x 1/4"	N722P16004B6	2
10	Phase-Barrier 25mm 4 pcs	1SDA066192R1	1

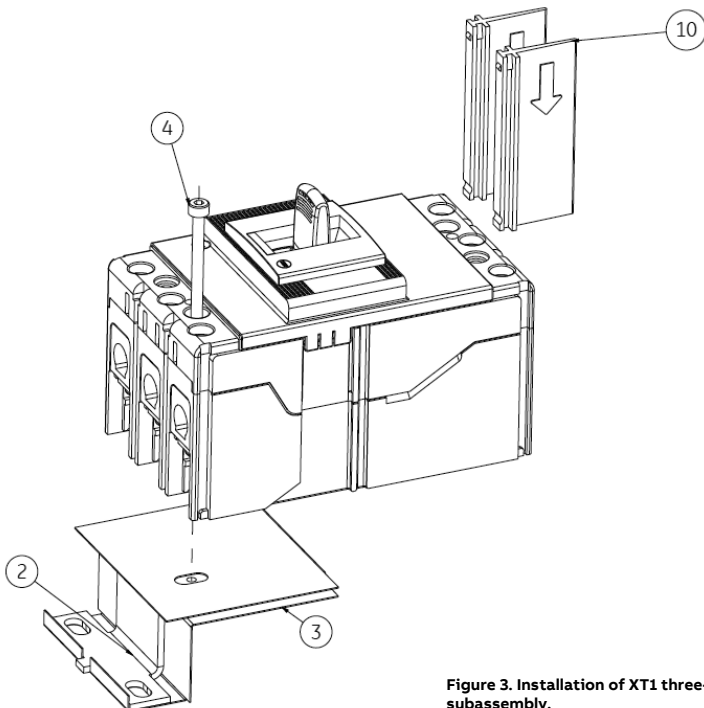

Figure 3. Installation of XT1 three-phase, three-pole breaker subassembly.

XT1 mounting kit

1. Remove the kit from its packaging and verify that all parts are present, as given in the packing list.
2. Remove the spool cover from the base by applying pressure to the handle on the u-shape snap.
3. Create circuit breaker subassembly following these steps:
 - a) Wrap the bracket insulation [3] around the mounting bracket [2].
 - b) Align breaker mounting holes with the mounting bracket and insulation assembly.
 - c) Fasten the breaker to the mounting bracket and insulation using the M4 hex head screw [4] to 9-11 lb-in.
 - d) Place the two 25mm phase barriers [10] on the "ON" side of the breaker by sliding them down as indicated by the arrow.
4. Drop the breaker assembly. Align the "ON" side breaker terminals on the breaker assembly over the spool holes inside the plastic base and place the flat [5] and lock [6] washers. Hand-tighten the three #10-24 x 3/8" screws [7] to locate the breaker assembly. On the other side, align the mounting bracket on the breaker assembly over the interior rail holes. Once aligned tighten the two #10-32 screws [9] to 27-33 lb-in. Tighten the three #10-24 x 3/8" screws [7] to 42 lb-in.
5. Place the remaining two 25mm phase barriers [10] on the "OFF" side of the breaker by sliding them down as indicated.

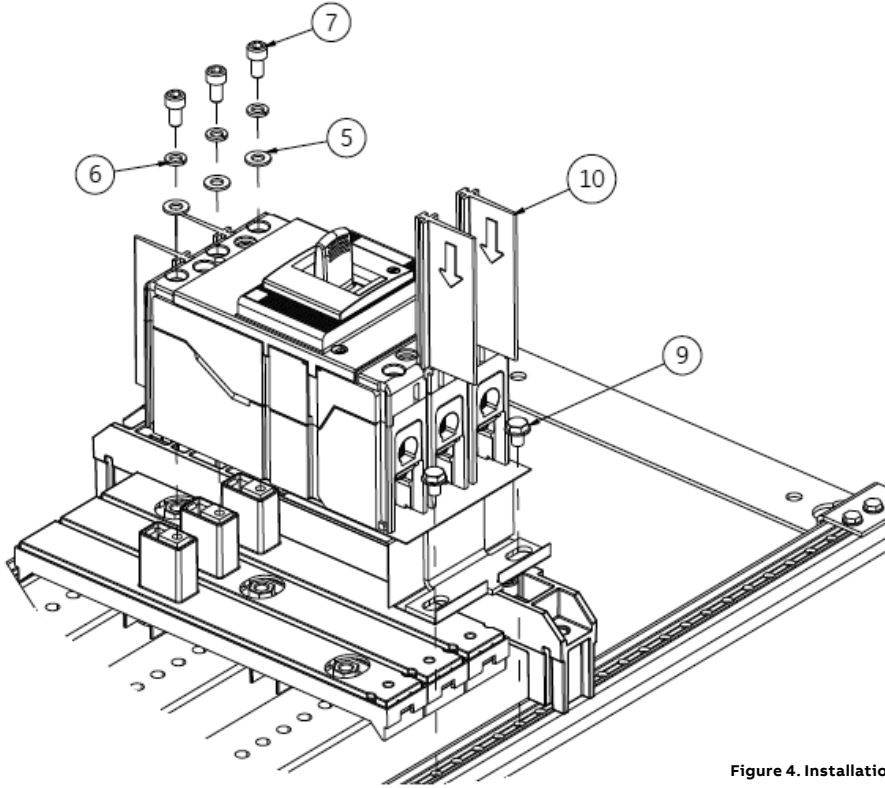

Figure 4. Installation of ASPXT13P on a lighting panelboard interior.

Table 3. Parts list for XT4 three-phase breaker mounting kit, catalog number ASPXT43P.

Item #	Description	Part #	Qty.
1	XT4 Rectangular Spool 250A	30014876527P2	3
2	Mounting Bracket, XT4	30014876551P2	1
3	Bracket Insulation, XT4	30014877432P2	1
4	Hex Socket Head Screw, 6-32 x 3"	N170P13048B70	2
5	Flat Washer, 1/4"	N402P41B6	3
6	Lock Washer, 1/4"	N405P41B6	3
7	Hex Socket Head Screw #1/4-20 x 5/8"	N170P21010B70	3
8	Thread Rolling Screw and Washer, #1/4-20 x 7/8"	315A7034P6	3
9	Screw, #10-32 x 1/4"	N722P16004B6	2
10	Phase-Barrier 25mm 4 pcs	1SDA075914R1	1

XT4 mounting kit

- Remove the kit from its packaging and verify that all parts are present, as given in the packing list.
- Create circuit breaker subassembly following these steps:
 - Wrap the bracket insulation [3] around the mounting bracket [2].
 - Align breaker mounting holes with the mounting bracket and insulation assembly.
 - Fasten the breaker to the mounting bracket and insulation assembly by using the two 6-32 x 3" hex socket screws [4] to 9-11 lb-in.
 - Align the three spools [1] over the breaker terminals on the "ON" side and place the flat [5] and spring [6] washers.
 - Fasten the spools [1] with the 1/4-20 x 5/8" hex socket head screws [7] to the breaker terminals to 40-50 lb-in.
 - Place the two 25 mm phase barrier [10] on the "ON" side of the breaker by sliding them down as indicated by the arrow.
- Drop the breaker assembly. Align the spools on the breaker subassembly over the strap inside of the plastic base. Hand-tighten the thread-rolling screws to locate the breaker assembly. On the other side, align the mounting bracket on the breaker assembly over the interior rail holes. Once aligned tighten the two #10-32 screws [9] to 27-36 in-lb. Tighten the three thread-rolling screws [8] to 27-33 lb-in.
- Place the remaining two-phase barriers [10] on the "OFF" side of the breaker by sliding them down as indicated.

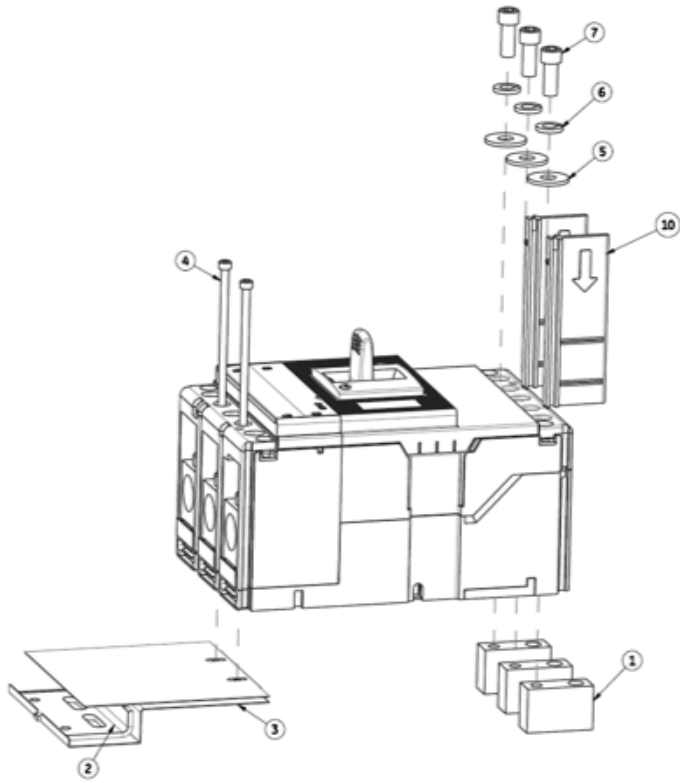

Figure 5. Installation of XT4 three-phase, three-pole breaker subassembly.

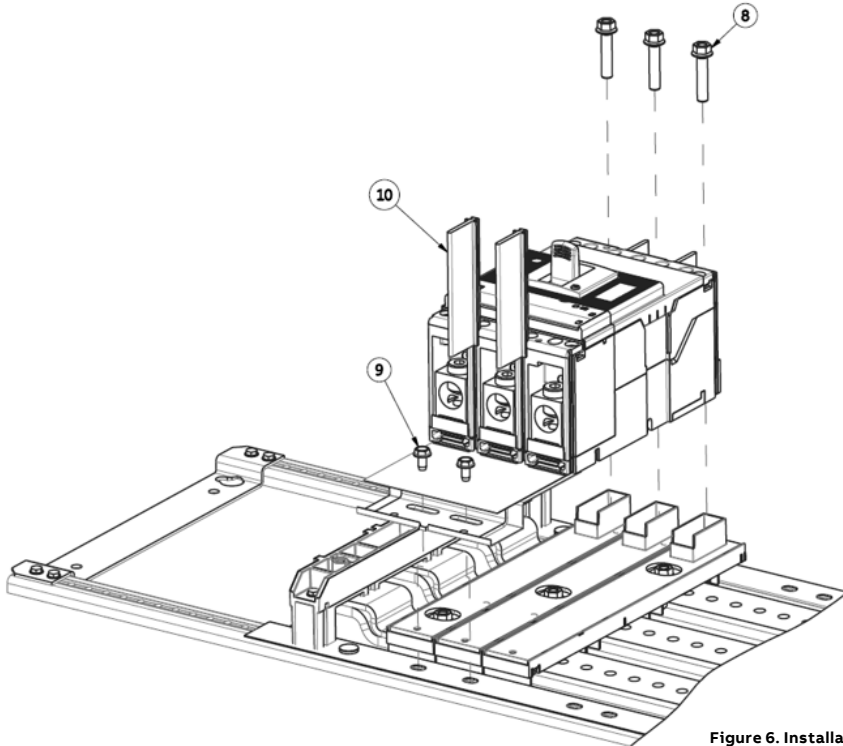

Figure 6. Installation of ASPXT43P on a lighting panelboard interior.