

BOTTOM VIEW OF MOUNTING AND CABLE ENTRANCE

CUSTOMER TERMINATION			
LOCATION	CONNECTION TYPE	HOLE SIZE	HOLE QTY
PRIMARY BUS BARS	STANDARD BUS BAR (LUGS ARE OPTIONAL)	.41 [10.3] DIA	1 PER BUS BAR
SECONDARY BUS BARS			

APPROX TOTAL WEIGHT LBS [KG]
CU WINDINGS: 640 [290]

kVA RATING:
K-FACTOR:
PRI VOLTAGE:
SEC VOLTAGE:
FREQ (Hz):
TEMP RISE:
WINDING MATL:
ES SHIELD:
SOUND LVL (dB):

NOTES:

- 1) ALL UNITS ARE UL LISTED AND ARE DESIGNED PER NEMA ST-20 STANDARDS.
- 2) THE TEMPERATURE RISE LISTED IS DETERMINED WHEN THE TRANSFORMER IS MOUNTED IN A STANDARD NEMA-2 ENCLOSURE.
- 3) TRANSFORMER IS DESIGNED FOR FLOOR MOUNTING. OPTIONAL WALL MOUNTING BRACKETS ARE AVAILABLE.
- 4) TRANSFORMER IS DRY TYPE, CLASS AA, WITH VENTILATED ENCLOSURE FOR INDOOR USE. OPTIONAL RAINSHIELD KITS ARE AVAILABLE TO ADAPT UNIT FOR TYPE 3R OUTDOOR USE WITHOUT VOIDING THE WARRANTY.
- 5) APPLICABLE WHEN OPTIONAL RAINSHIELDS ARE INSTALLED. RAINSHIELDS ARE SHIPPED IN KITS FOR FIELD INSTALLATION.
- 6) CABLE ENTRANCE IS PERMITTED THROUGH THE LEFT SIDE, RIGHT SIDE AND/OR BOTTOM ENCLOSURE PANELS ONLY. CABLE ENTRANCE IS NOT PERMITTED THROUGH THE FRONT, REAR OR TOP PANELS.
- 7) FOR LIFTING OTHER THAN WITH A FORK TRUCK, REMOVE TOP COVER AND USE 1" [25 MM] DIAMETER HOLES IN THE TOP CORE CLAMPS.
- 8) ENCLOSURE PAINT COLOR IS ANSI #61 GRAY.
- 9) 6" [152 MM] MINIMUM CLEARANCE IS REQUIRED FROM ALL WALLS.

JOB NAME: SPEEDI PROP:	UNLESS OTHERWISE SPECIFIED ALL DIMENSIONS ARE INCH [MM]	GE Energy
	THIRD ANGLE PROJECTION 	DRY TYPE TRANSFORMER OUTLINE DRAWING TYPE QL, HARMONIC MITIGATING, 3-PHASE (ENCLOSED UNIT)
CAD DRAWING: 303B431AAP073	SHEET 1 OF 2	CATALOG # REV 3

FRONT VIEW

SIDE VIEW

ISOMETRIC VIEW

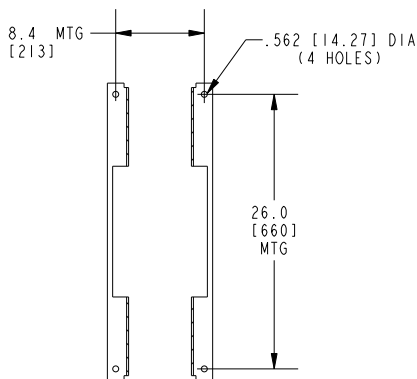
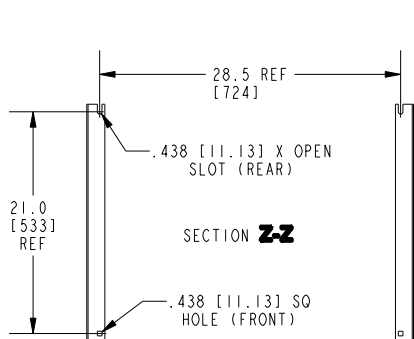
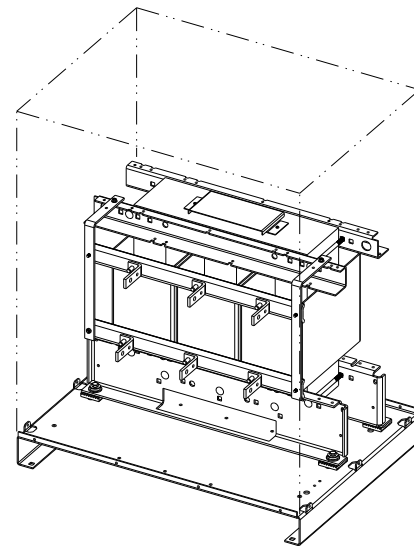
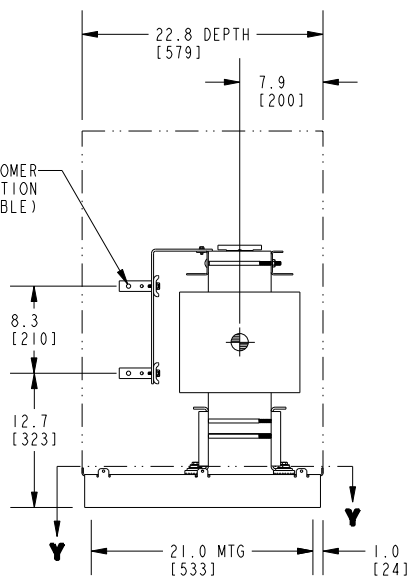
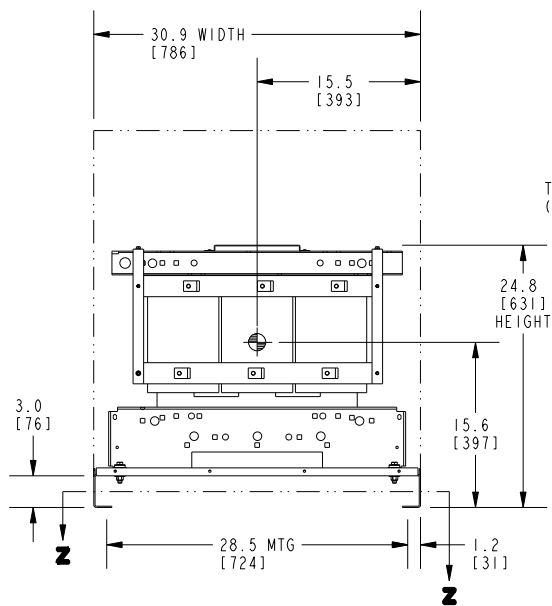

BOTTOM VIEW OF MOUNTING HOLE PATTERN

SECTION Y-Y

BOTTOM VIEW OF MOUNTING HOLE PATTERN WITHOUT BASE ATTACHED

**APPROX TOTAL WEIGHT LBS [KG]
CU WINDINGS: 540 [245]**

**kVA RATING:
K-FACTOR:
PRI VOLTAGE:
SEC VOLTAGE:
FREQ (Hz):
TEMP RISE:
WINDING MATL:
ES SHIELD:
SOUND LVL (dB):**

NOTES:

- 1) ALL UNITS ARE UL LISTED AND ARE DESIGNED PER NEMA ST-20 STANDARDS.
- 2) THE TEMPERATURE RISE LISTED IS DETERMINED WHEN THE TRANSFORMER IS MOUNTED IN A STANDARD NEMA-2 ENCLOSURE.
- 3) TRANSFORMER IS DRY TYPE, CLASS AA FOR INDOOR USE.
- 4) FOR LIFTING OTHER THAN WITH A FORK TRUCK, USE 1" [25 MM] DIAMETER HOLES IN THE TOP CORE CLAMPS.
- 5) BASE PAINT COLOR IS ANSI #61 GRAY.
- 6) 6" [152 MM] MINIMUM CLEARANCE IS REQUIRED FROM ALL WALLS.
- 7) Ⓞ INDICATES APPROXIMATE CENTER OF GRAVITY.

CUSTOMER TERMINATION			
LOCATION	CONNECTION TYPE	HOLE SIZE	HOLE QTY
PRIMARY BUS BARS	STANDARD BUS BAR (LUGS ARE OPTIONAL)	.41 [10.3] DIA	1 PER BUS BAR
SECONDARY BUS BARS			

JOB NAME:

SPEEDI PROP:

UNLESS OTHERWISE SPECIFIED ALL DIMENSIONS ARE INCH [MM]



GE Energy

THIRD ANGLE PROJECTION

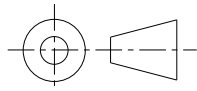

**DRY TYPE TRANSFORMER OUTLINE DRAWING
TYPE QL, HARMONIC MITIGATING, 3-PHASE
(CORE & COIL UNIT)**

CAD DRAWING: 303B431AAP073

SHEET 2 OF 2

CATALOG #

REV 3