

FRONT VIEW

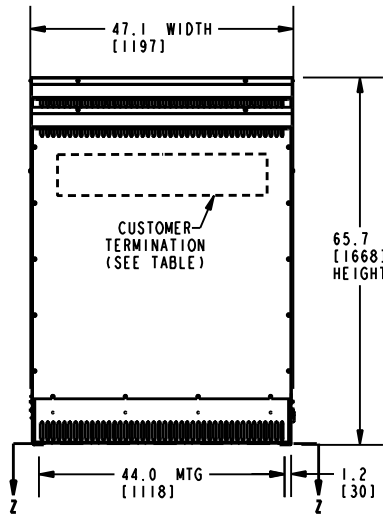

SIDE VIEW

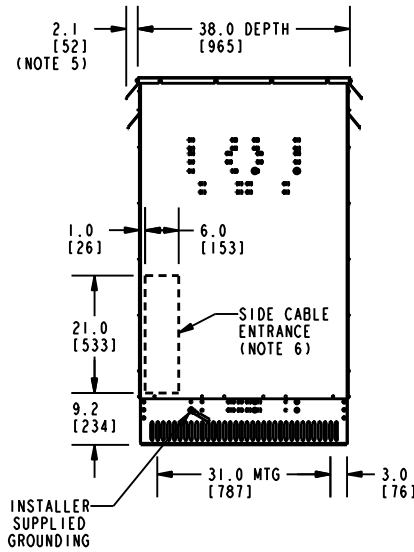

ISOMETRIC VIEW

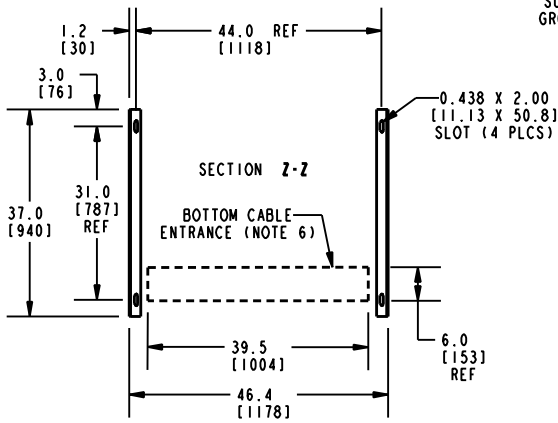
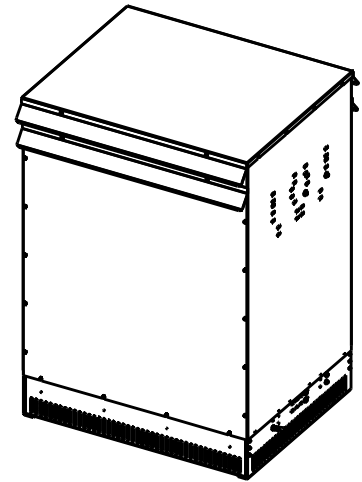

BOTTOM VIEW OF MOUNTING HOLE PATTERN

CUSTOMER TERMINATION			
LOCATION	CONNECTION TYPE	HOLE SIZE	HOLE QTY
PRIMARY BUS BARS	STANDARD BUS BAR (LUGS ARE OPTIONAL)	.56 [14.2] DIA	4 PER BUS BAR
SECONDARY BUS BARS			6 PER BUS BAR

APPROX TOTAL WEIGHT LBS [KG]
 AL WINDINGS: 2265 [1028]
 CU WINDINGS: 2900 [1316]

kVA RATING:
K-FACTOR:
PRI VOLTAGE:
SEC VOLTAGE:
FREQ (Hz):
TEMP RISE:
WINDING MATL:
ES SHIELD:
SOUND LVL (dB):

NOTES:

- 1) ALL UNITS ARE UL LISTED AND ARE DESIGNED PER NEMA ST-20 STANDARDS.
- 2) THE TEMPERATURE RISE LISTED IS DETERMINED WHEN THE TRANSFORMER IS MOUNTED IN A STANDARD NEMA 2 ENCLOSURE.
- 3) TRANSFORMER IS DESIGNED FOR FLOOR MOUNTING. OPTIONAL WALL MOUNTING BRACKETS ARE NOT AVAILABLE FOR THIS DESIGN/STYLE.
- 4) TRANSFORMERS ARE DRY TYPE, CLASS AA, WITH VENTILATED ENCLOSURES FOR INDOOR USE. OPTIONAL RAINSHIELD KITS ARE AVAILABLE TO ADAPT ALL SIZES FOR TYPE 3R OUTDOOR USE WITHOUT VOIDING THE WARRANTY.
- 5) APPLICABLE WHEN OPTIONAL RAINSHIELDS ARE INSTALLED. RAINSHIELDS ARE SHIPPED IN KITS FOR FIELD INSTALLATION.
- 6) CABLE ENTRANCE IS PERMITTED THROUGH THE LEFT SIDE, RIGHT SIDE AND/OR BOTTOM ENCLOSURE PANELS ONLY. CABLE ENTRANCE IS NOT PERMITTED THROUGH THE FRONT, REAR OR TOP PANELS.
- 7) FOR MOVING THE UNIT WITH A PALLET JACK OR FORK TRUCK, INSERT FORKS COMPLETELY UNDERNEATH BOTH FRONT AND REAR LIFTING GRILLS. FOR CRANE LIFTING USE 1" [25 MM] DIAMETER HOLES IN THE TOP CORE CLAMPS.
- 8) ENCLOSURE PAINT COLOR IS ANSI #61 GRAY.
- 9) 6" [152 MM] MINIMUM CLEARANCE IS REQUIRED FROM ALL WALLS.

JOB NAME: SPEEDI PROP: electrification.us.abb.com	UNLESS OTHERWISE SPECIFIED ALL DIMENSIONS ARE INCH [MM]	Transformers by ABB
	THIRD ANGLE PROJECTION 	
CAD DRAWING: 303B912AAP179	SHEET 1 OF 2	CATALOG # _____ REV 1

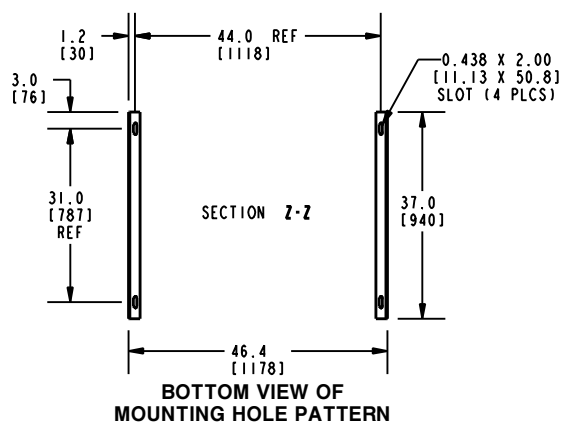
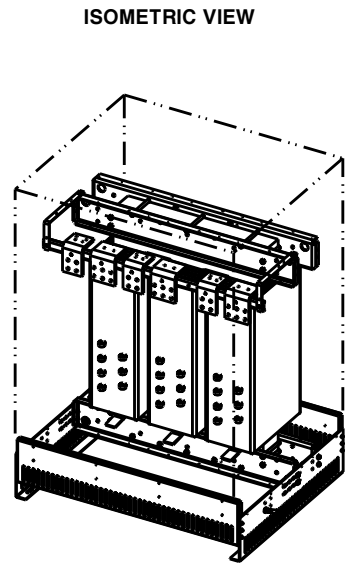
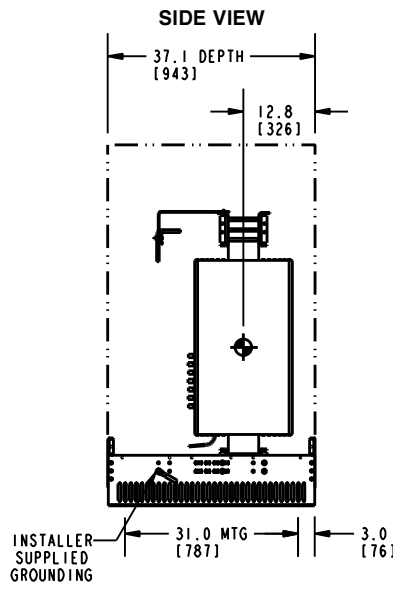
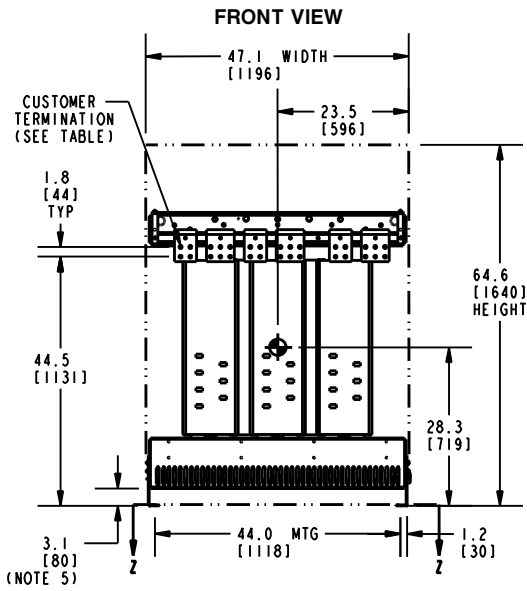

CUSTOMER TERMINATION			
LOCATION	CONNECTION TYPE	HOLE SIZE	HOLE QTY
PRIMARY BUS BARS	STANDARD BUS BAR (LUGS ARE OPTIONAL)	.56 [14.2] DIA	4 PER BUS BAR
SECONDARY BUS BARS			6 PER BUS BAR

APPROX TOTAL WEIGHT LBS [KG]
 AL WINDINGS: 2265 [1028]
 CU WINDINGS: 2900 [1316]

kVA RATING:
 K-FACTOR:
 PRI VOLTAGE:
 SEC VOLTAGE:
 FREQ (Hz):
 TEMP RISE:
 WINDING MATL:
 ES SHIELD:
 SOUND LVL (dB):

- NOTES:
- 1) ALL UNITS ARE UL LISTED AND ARE DESIGNED PER NEMA ST-20 STANDARDS.
 - 2) THE TEMPERATURE RISE LISTED IS DETERMINED WHEN THE TRANSFORMER IS MOUNTED IN A STANDARD NEMA 2 ENCLOSURE.
 - 3) TRANSFORMER IS DESIGNED FOR FLOOR MOUNTING. OPTIONAL WALL MOUNTING BRACKETS ARE NOT AVAILABLE FOR THIS DESIGN/STYLE.
 - 4) TRANSFORMERS ARE DRY TYPE, CLASS AA FOR INDOOR USE.
 - 5) FOR MOVING THE UNIT WITH A PALLET JACK OR FORK TRUCK, INSERT FORKS COMPLETELY UNDERNEATH BOTH FRONT AND REAR LIFTING GRILLS. FOR CRANE LIFTING USE 1.5" [38 MM] DIAMETER HOLES IN THE TOP CORE CLAMPS.
 - 6) PAINTED GRILL AND MOUNTING BRACKET COLOR IS ANSI #61 GRAY.
 - 7) 6" [152 MM] MINIMUM CLEARANCE IS REQUIRED FROM ALL WALLS.
 - 8) ⦿ INDICATES APPROXIMATE CENTER OF GRAVITY.

JOB NAME: SPEEDI PROP:	UNLESS OTHERWISE SPECIFIED ALL DIMENSIONS ARE INCH [MM]	Transformers by ABB
	THIRD ANGLE PROJECTION	
electrification.us.abb.com		DRY TYPE TRANSFORMER OUTLINE DRAWING TYPE QL, TP1, 3-PHASE (VIEWS WITHOUT ENCLOSURE PANELS)
CAD DRAWING: 303B912AAP179	SHEET 2 OF 2	CATALOG # _____ REV 1