

**STYLE AA
(TERMINAL BLOCKS)**

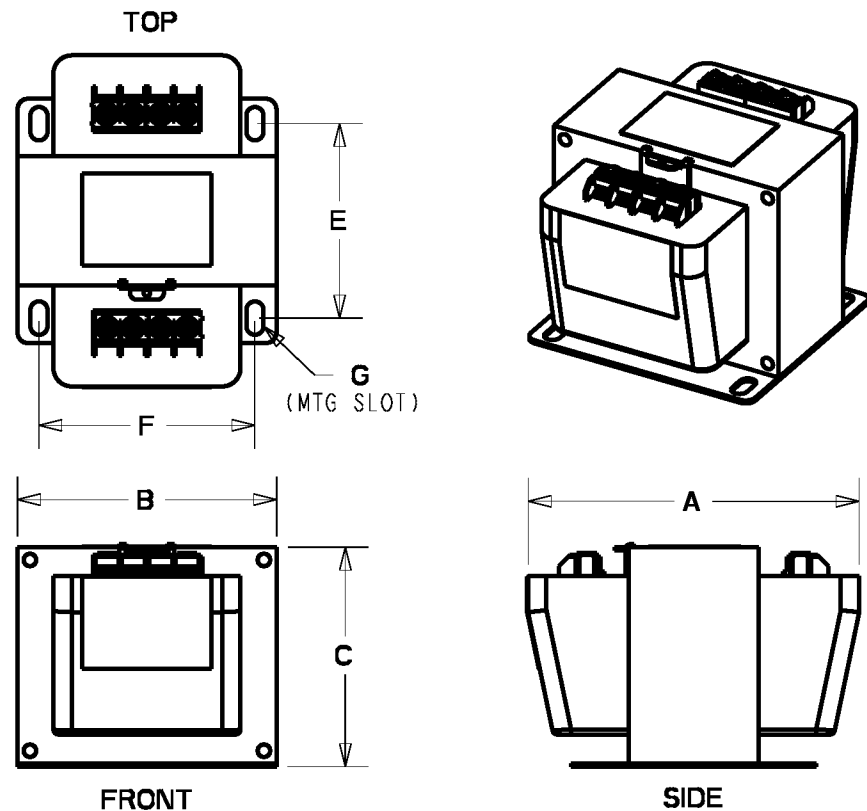

**STYLE AB
(LEADS OUT)**

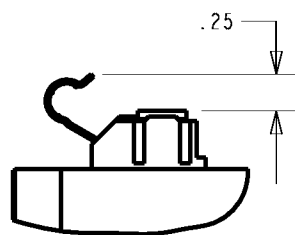
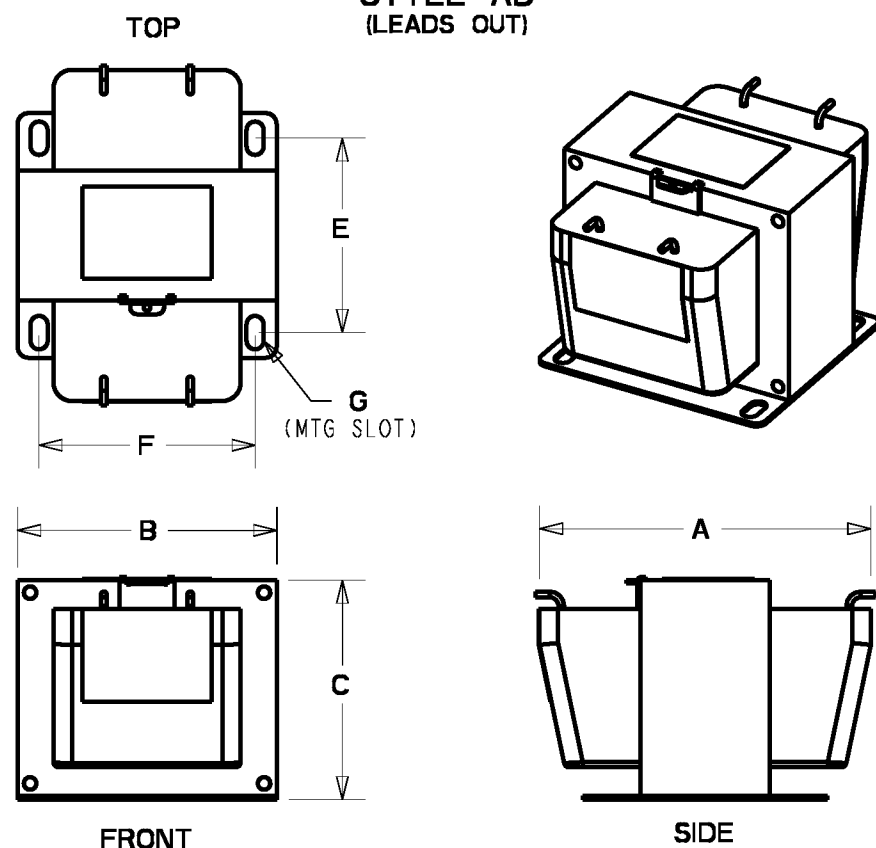

9T58K0000G09 FUSE CLIPS
250 VOLTS, 20 AMPS MAX FOR
1/4" DIA X 1 1/4" FUSES

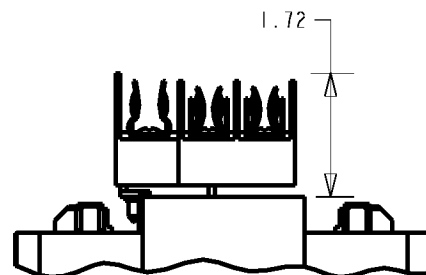

FUSE BLOCKS
NOTE: FUSE BLOCK OPTION MAY INCLUDE
1, 2, OR 3 POLE FUSE BLOCK

STYLE	PART	FRAME	REF 60 HZ KVA	APPROX WEIGHT (LBS)	MAXIMUM ENVELOPE			MOUNTING		
					DEPTH A	WIDTH B	HEIGHT C	DEPTH E	WIDTH F	SLOT G
AA	P06100	6100	.050	2.6	4.00	3.06	2.68	2.16	2.50	.219 X .750
AB					3.25					
AA	P06125	6125	.075	3.0	4.25	3.06	2.68	2.41	2.50	.219 X .750
AB					3.50					
AA	P06150	6150	.087	3.4	4.50	3.06	2.68	2.66	2.50	.219 X .750
AB					3.75					
AA	P08100	8100	.100	3.9	4.12	3.81	3.28	2.16	3.12	.219 X .750
AB					3.42					
AA	P08150	8150	.150	5.5	4.62	3.81	3.28	2.66	3.12	.219 X .750
AB					3.92					
AA	P08175	8175	.200	6.3	4.88	3.81	3.28	2.91	3.12	.219 X .750
AB					4.18					
AA	P08200	8200	.250	7.0	5.12	3.81	3.28	3.16	3.12	.219 X .750
AB					4.42					
AA	P08250	8250	.375	8.3	5.62	3.81	3.28	3.66	3.12	.219 X .750
AB					4.92					
AA	P10225	10225	.500	11.6	5.75	4.56	3.90	3.38	3.75	.297 X .580
AB										
AA	P12225	12225	.750	13.0	5.81	5.31	4.56	3.38	4.00	.297 X .580
AB										
AA	P12300	12300	1.00	17.5	6.56	5.31	4.56	4.13	4.00	.297 X .580
AB										
AA	P14225	14225	1.50	29.0	6.31	6.81	5.81	3.38	5.50	.297 X .580
AB										
AA	P14300	14300	2.00	35.5	7.06	6.81	5.81	4.13	5.50	.297 X .580
AB										
AA	P14475	14475	3.00	51.5	8.81	6.81	5.81	5.88	5.50	.297 X .580
AB										

NOTES:

- 1) STYLE "AA" TRANSFORMERS: RECOMMENDED TERMINAL SCREW TORQUE 6-10 IN LB
- 2) STYLE "AB" TRANSFORMERS: STANDARD LEAD LENGTH IS 10"

**** OUTLINE NUMBERING METHOD ****

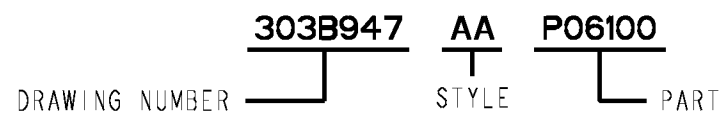

 **GE Industrial Systems**

INDUSTRIAL CONTROL TYPE-IP TRANSFORMERS
DRY-TYPE, SINGLE-PHASE, CORE-AND-COIL TRANSFORMERS
FOR CONTROL, MACHINE TOOL, AND POWER APPLICATIONS
UL LISTED - CSA CERTIFIED

DATE 10/15/01	REV LEVEL 002	DIST	DRAWING NUMBER 303B947	SHEET 1 OF 1
------------------	------------------	------	----------------------------------	-----------------