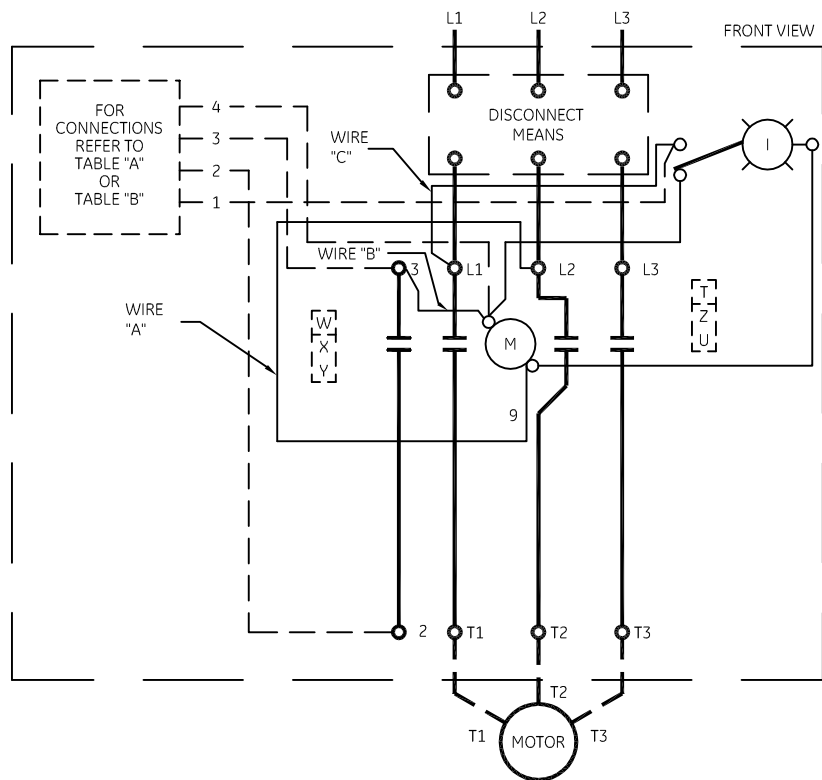

TABLE A STANDARD PILOT DEVICES	TABLE B OIL-TIGHT PILOT DEVICES
START-STOP 	START-STOP
PUSHBUTTONS OFF ON (OMIT WIRE "B")	PUSHBUTTONS OFF ON (OMIT WIRE "B")
2 POSITION SELECTOR SWITCH HAND — RED — 1 OFF — WHITE — 3 AUTO — BLACK — 4 (OMIT WIRE "B")	2 POSITION SELECTOR SWITCH HAND — OFF — 1 AUTO — X — 3 (OMIT WIRE "B")
REMOTE DEVICE 3 POSITION SELECTOR SWITCH	REMOTE DEVICE 3 POSITION SELECTOR SWITCH



USE 75°C COPPER CONDUCTORS ONLY,
FOR FIELD WIRING.

-NOMENCLATURE-
M-LINE CONTACTOR
I-INDICATING LIGHT
FU-FUSE
X-INDICATES CONTACT CLOSED

CONTROL
CIRCUIT FUSING

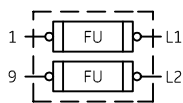

TORQUE LINE AND LOAD TERMINALS AS SHOWN AT RIGHT	CR305	CR307	CR308	CR387	LINE AS MARKED	LOAD AS MARKED
	20 LB-IN	20 LB-IN	35 LB-IN	AS MARKED	20 LB-IN	20 LB-IN

NOTE: REFER TO THE NATIONAL ELECTRICAL CODE.
ADDITIONAL CONTROL CIRCUIT OVER-CURRENT PROTECTION MAY BE REQUIRED.

FOR 1-PHASE OPERATION - CHANGE CONNECTION OF WIRE "A" FROM L2 TO L3. CONNECT LINE TO L1 AND L3 AND LOAD TO T1 AND T3.

FOR CONTACTOR WITHOUT DISCONNECT MEANS - WIRE LINE DIRECT TO L1, L2 AND L3 ON CONTACTOR.

FOR EXTRA AUXILIARY CONTACTS- A MAXIMUM OF 4 CONTACTS MAY BE ADDED AT POSITIONS T,U,W,X,Y & Z FOR SIZE 0 & 1 ONLY.

FOR SEPARATE CONTROL SOURCE - OMIT WIRE "A" AND WIRE "C" CONNECT SEPARATE CONTROL SOURCE TO 9 ON COIL AND TO 1 ON PILOT DEVICE. WIRES "A" AND "C" ARE OMITTED AT FACTORY ON ALL CONTACTORS WITH A COIL VOLTAGE OF 120V OR LESS.

FOR CSA - GND KIT
1/2-IN CONDUIT
3/4-IN CONDUIT

55-213403G001
55-213403G002

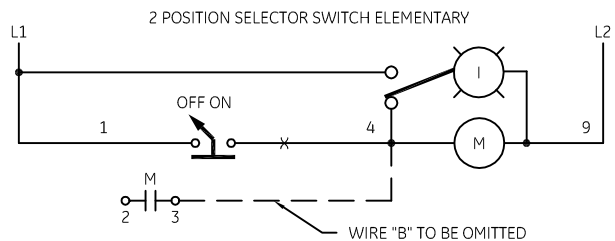
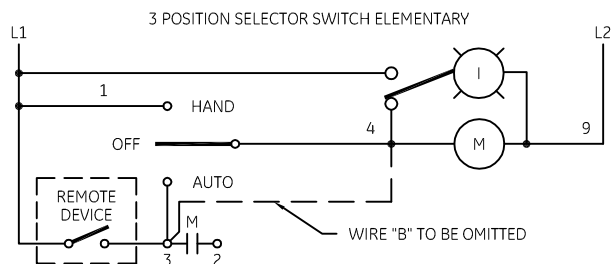
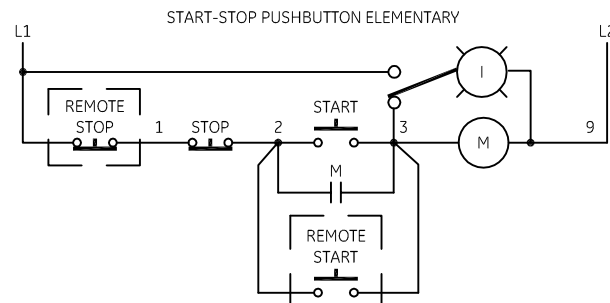

imagination at work

WIRING DIAGRAM
FVNR SIZE 00, 0 & 1

AN #	THIRD ANGLE PROJECTION	SHEET #
09-9111		1 OF 1

DWG NO.	DATE	REV
55-196611	08/12/2009	3