

-NOMENCLATURE-
 FS&SS-FAST, SLOW-SPEED CONTACTORS
 MECHANICALLY AND ELECTRICALLY
 INTERLOCKED.
 OL-OVERLOAD RELAY.
 I-INDICATING LIGHT
 X-INDICATES CONTACT CLOSED

FOR 2 PHASE, 3 WIRE OPERATION- L2 IS
 COMMON LINE. CONNECT MOTOR T1 TO
 CONTROLLER T1, MOTOR T3 & T4 TO
 CONTROLLER T2, AND 2 PHASE FORMS
 HAVE SAME RATING AS 3 PHASE FORMS.

WIRES B AND C ARE OMITTED.
 IF LIMIT SWITCHES ARE NOT
 USED ADD WIRES B AND C.

	LINE	LOAD
USE 75°C, COPPER CON- DUCTORS ONLY, FOR FIELD WIRING. TORQUE LINE AND LOAD TERMINALS AS SHOWN AT RIGHT:	CR309 20 LB-IN	20 LB-IN
	CR310 AS MARKED	20 LB-IN
	CR311 35 LB-IN	20 LB-IN
	CR390 AS MARKED	20 LB-IN

NOTE: ADDITIONAL OVER-CURRENT PROTECTION
 MAY BE REQUIRED. REFER TO THE
 NATIONAL ELECTRICAL CODE OR LOCAL
 ELECTRICAL CODE AS REQUIRED.

GROUND KIT

1/2-IN CONDUIT	55-213403G001
3/4-IN CONDUIT	55-213403G002
1-IN CONDUIT	55-213403G003
1 1/4-IN CONDUIT	55-213403G004
1 1/2-IN CONDUIT	55-213403G005
2-IN CONDUIT	55-213403G006
2 1/2-IN CONDUIT	55-213403G007
3-IN CONDUIT	55-213403G008

ALTERNATE MARKINGS FOR FORWARD AND
 REVERSE ARE OPEN AND CLOSE, AND
 RAISE AND LOWER.

FOR EXTRA AUXILIARY CONTACTS A MAXIMUM
 OF 4 CONTACTS MAY BE ADDED AT POSITIONS
 W,X,Y & Z.

FOR SEPARATE CONTROL SOURCE-REMOVE WIRES "A" & "D"
 AND CONNECT SEPARATE CONTROL SOURCE TO 9 ON OL
 AND TO 1 ON PILOT DEVICE. WIRES "A" & "D" ARE
 OMITTED AT FACTORY ON ALL CONTROLLERS WITH A
 COIL VOLTAGE OF 120V OR LESS.

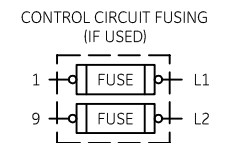
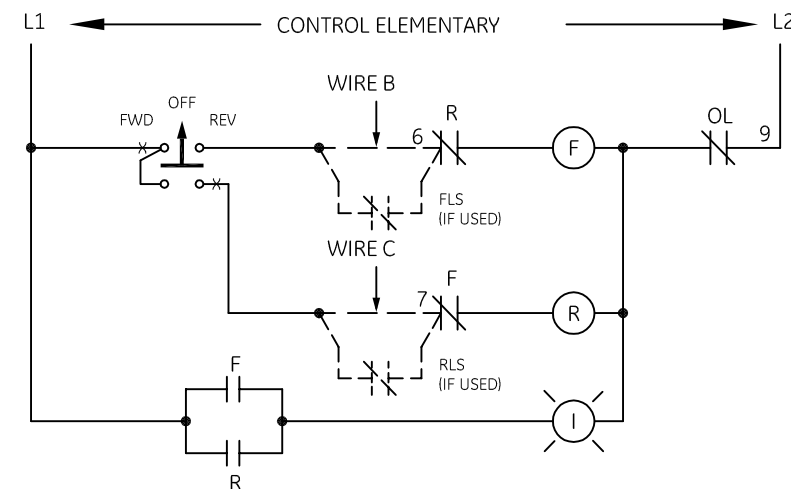
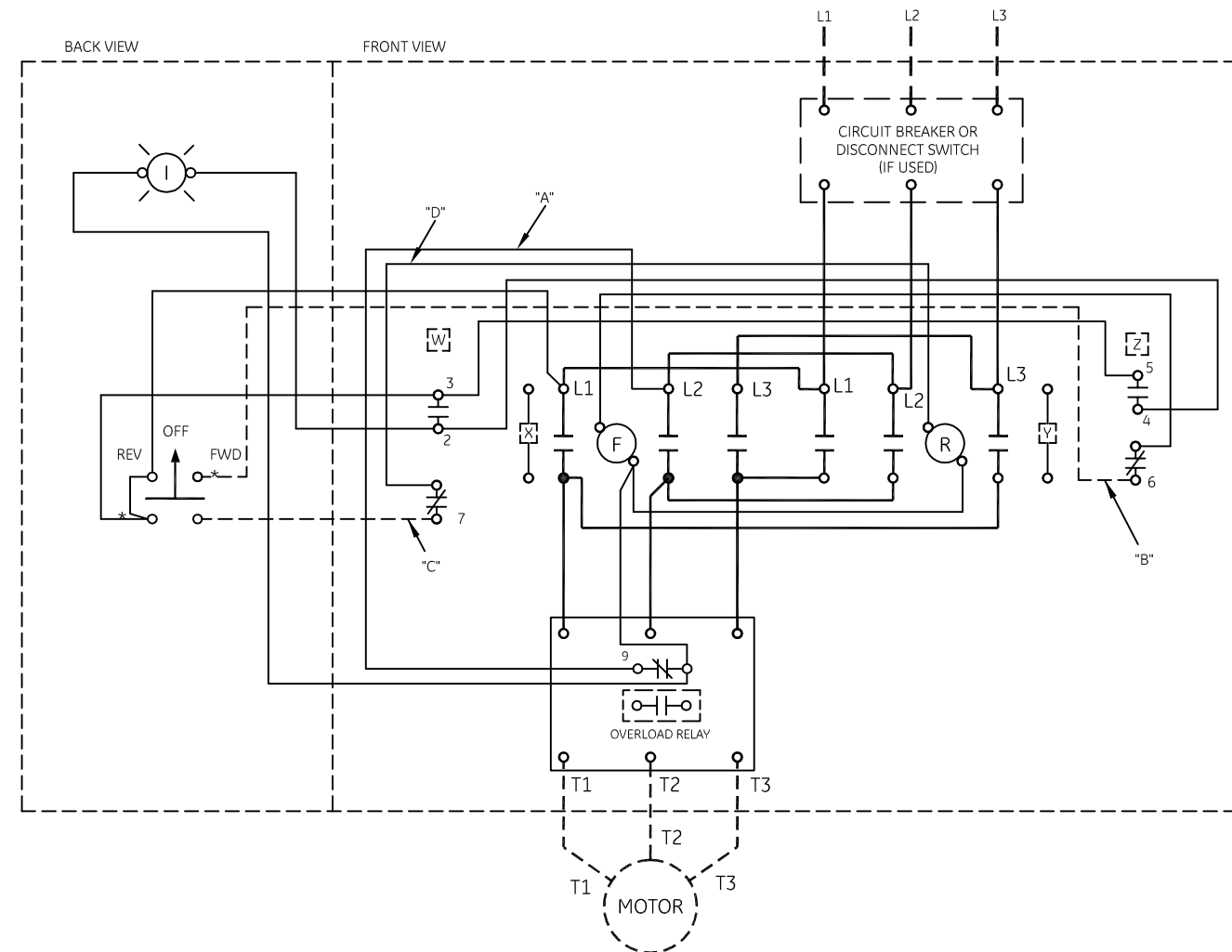

GE imagination at work

WIRING DIAGRAM
 REVERSER SIZE 0 & 1

AN #	THIRD ANGLE PROJECTION	SHEET #	DWG NO.	DATE	REV
09-9115		1 OF 1	55-532646	09/08/2009	3