

INSTALL OVERLOAD HEATERS

FOR	LOW SPEED	HIGH SPEED
IN	2OL	1OL

CONNECTION TABLE

PANEL	A	B	C	D	E	F
MOTOR	T1	T2	T3	T6	T4	T5

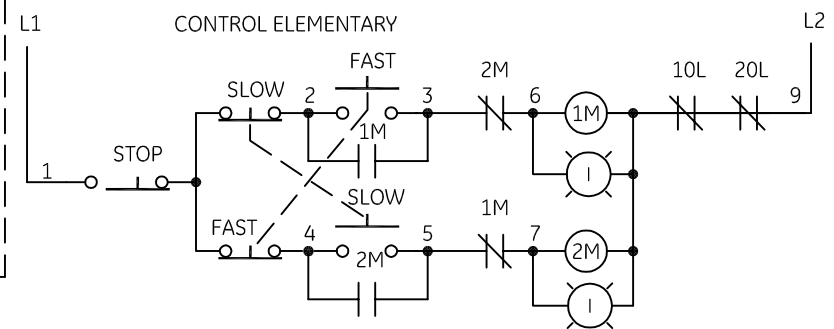

-NOMENCLATURE-
1M&2M-SPEED CONTACTORS MECHANICALLY & ELECTRICALLY INTERLOCKED.
1OL,2OL-OVERLOAD RELAY
I-INDICATING LIGHT
FU-FUSE

	LINE	LOAD
USE 75°C, COPPER CONDUCTORS ONLY, FOR FIELD WIRING. TORQUE LINE AND LOAD TERMINALS AS SHOWN AT RIGHT:	CR309	20 LB-IN
	CR310	AS MARKED
	CR311	35 LB-IN
	CR390	AS MARKED
		20 LB-IN
		20 LB-IN
		20 LB-IN

NOTE: ADDITIONAL OVER-CURRENT PROTECTION MAY BE REQUIRED. REFER TO THE NATIONAL ELECTRICAL CODE OR LOCAL ELECTRICAL CODE AS REQUIRED.

GROUND KIT

1/2-IN CONDUIT	55-213403G001
3/4-IN CONDUIT	55-213403G002
1-IN CONDUIT	55-213403G003
1 1/4-IN CONDUIT	55-213403G004
1 1/2-IN CONDUIT	55-213403G005
2-IN CONDUIT	55-213403G006
2 1/2-IN CONDUIT	55-213403G007
3-IN CONDUIT	55-213403G008

ALTERNATIVE LEGENDS FOR FAST AND SLOW ARE HIGH AND LOW.

FOR SEPARATE CONTROL SOURCE-REMOVE WIRES "A" & "B" AND CONNECT SEPARATE CONTROL SOURCE TO 9 ON OL AND TO 1 ON PILOT DEVICE. WIRES "A" & "B" ARE OMITTED AT FACTORY ON ALL CONTROLLERS WITH A COIL VOLTAGE OF 120V OR LESS.

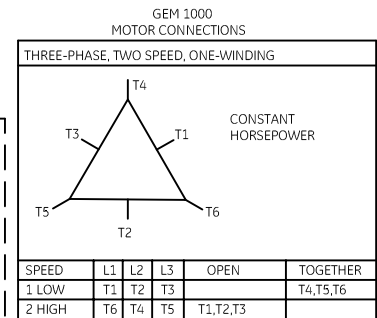
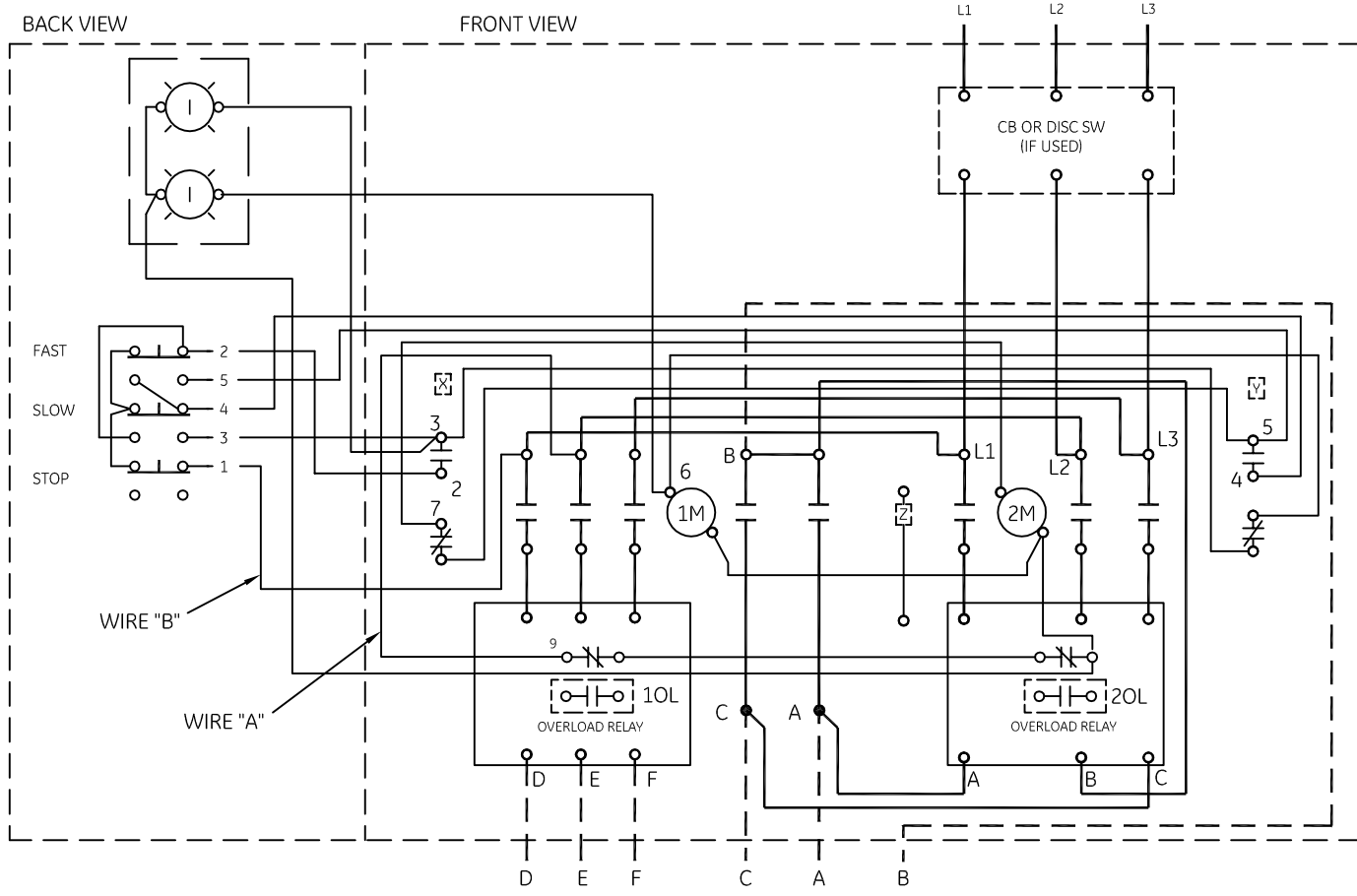

INSTALL OVERLOAD HEATERS

FOR	LOW SPEED	HIGH SPEED
IN	1OL	2OL

CONNECTION TABLE

PANEL	A	B	C	D	E	F
MOTOR	T1	T2	T3	T6	T4	T5

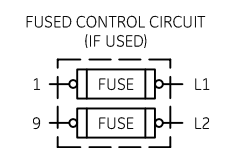
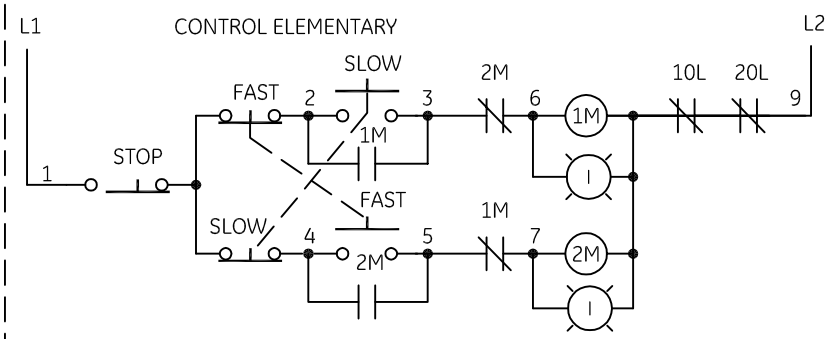

WIRING DIAGRAM
2 SPEED - 1 WINDING SIZE 0 & 1

AN #	THIRD ANGLE PROJECTION	SHEET #	DWG NO.	DATE	REV
09-9115		1 OF 1	55-532693	09/08/2009	3