

-NOMENCLATURE-  
 F-FAST CONTACTOR  
 S-SLOW CONTACTOR  
 OL-THERMAL OVERLOAD RELAY  
 I-INDICATING LIGHT  
 FU-FUSE  
 X-INDICATES CONTACT CLOSED  
 TR-TIMER(Delay on Energization Relay)  
 T.C.-TIME CLOSING CONTACT  
 T.O.-"OPENING"  
 ALTERNATE LEGENDS FOR FAST AND SLOW  
 ARE HIGH AND LOW

**GROUND KIT**

1/2-IN CONDUIT	55-213403G001
3/4-IN CONDUIT	55-213403G002
1-IN CONDUIT	55-213403G003
1 1/4-IN CONDUIT	55-213403G004
1 1/2-IN CONDUIT	55-213403G005
2-IN CONDUIT	55-213403G006
2 1/2-IN CONDUIT	55-213403G007
3-IN CONDUIT	55-213403G008

NOTE: ADDITIONAL OVER-CURRENT PROTECTION  
 MAY BE REQUIRED. REFER TO THE  
 NATIONAL ELECTRICAL CODE OR LOCAL  
 ELECTRICAL CODE AS REQUIRED.

FOR EXTRA AUXILIARY CONTACTS- A MAXIMUM OF 4  
 CONTACTS MAY BE ADDED AT POSITIONS  
 W,X,Y,& Z.

FOR CONTROLLER WITHOUT DISCONNECT MEANS-WIRE  
 LINE DIRECT TO L1, L2 AND L3 ON CONTROLLER.

USE 75°C COPPER  
 CONDUCTORS ONLY. FOR  
 FIELD WIRING. TORQUE  
 LINE AND LOAD TERMINALS  
 AS SHOWN AT RIGHT:

SIZE	TERMINAL TIGHTENING TORQUE (LB-IN)			
	LOAD SIDE		LINE SIDE	
2	THERMAL OL 50	ELECTRONIC OL 20	CR309 50	CR310,390 AS MARKED
3	150	200	150	AS MARKED
4	200	200	200	AS MARKED

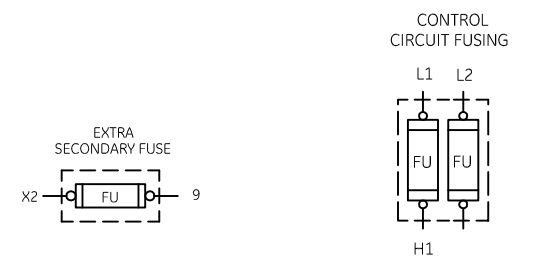
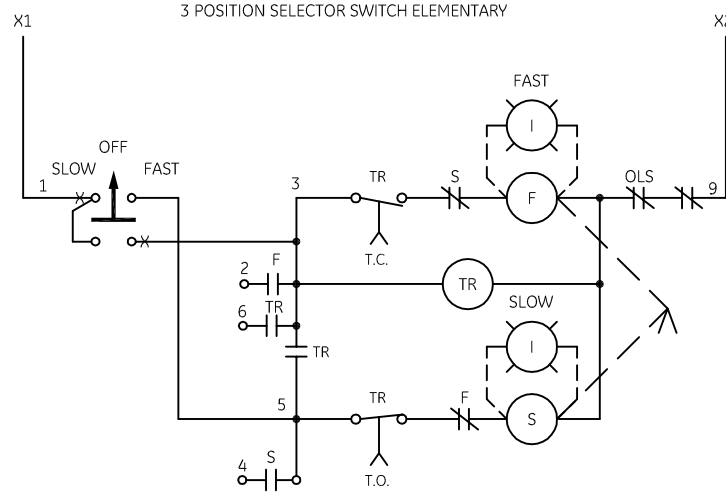
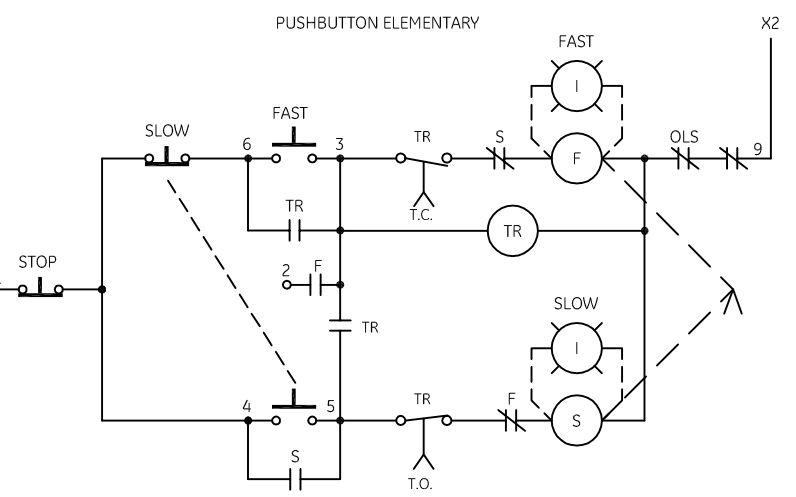
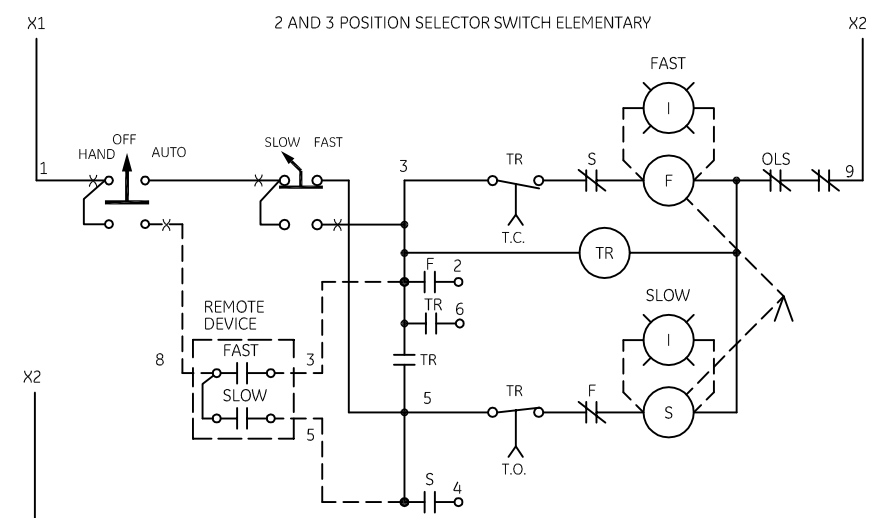
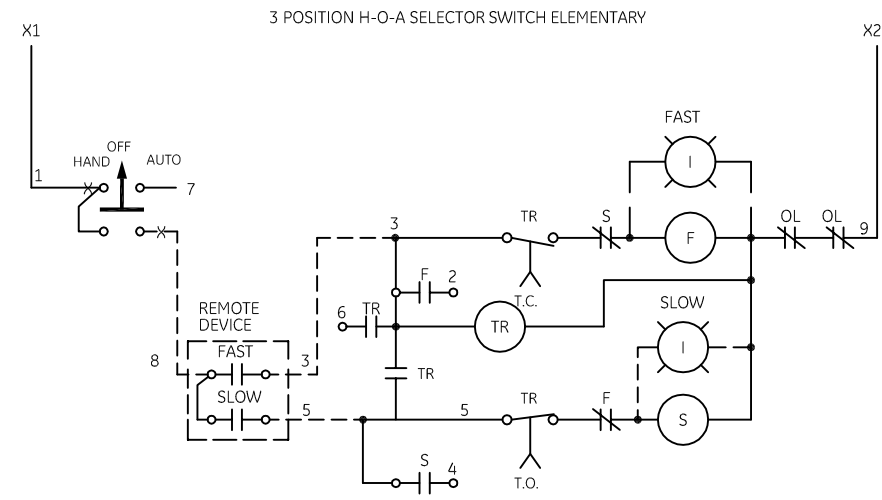
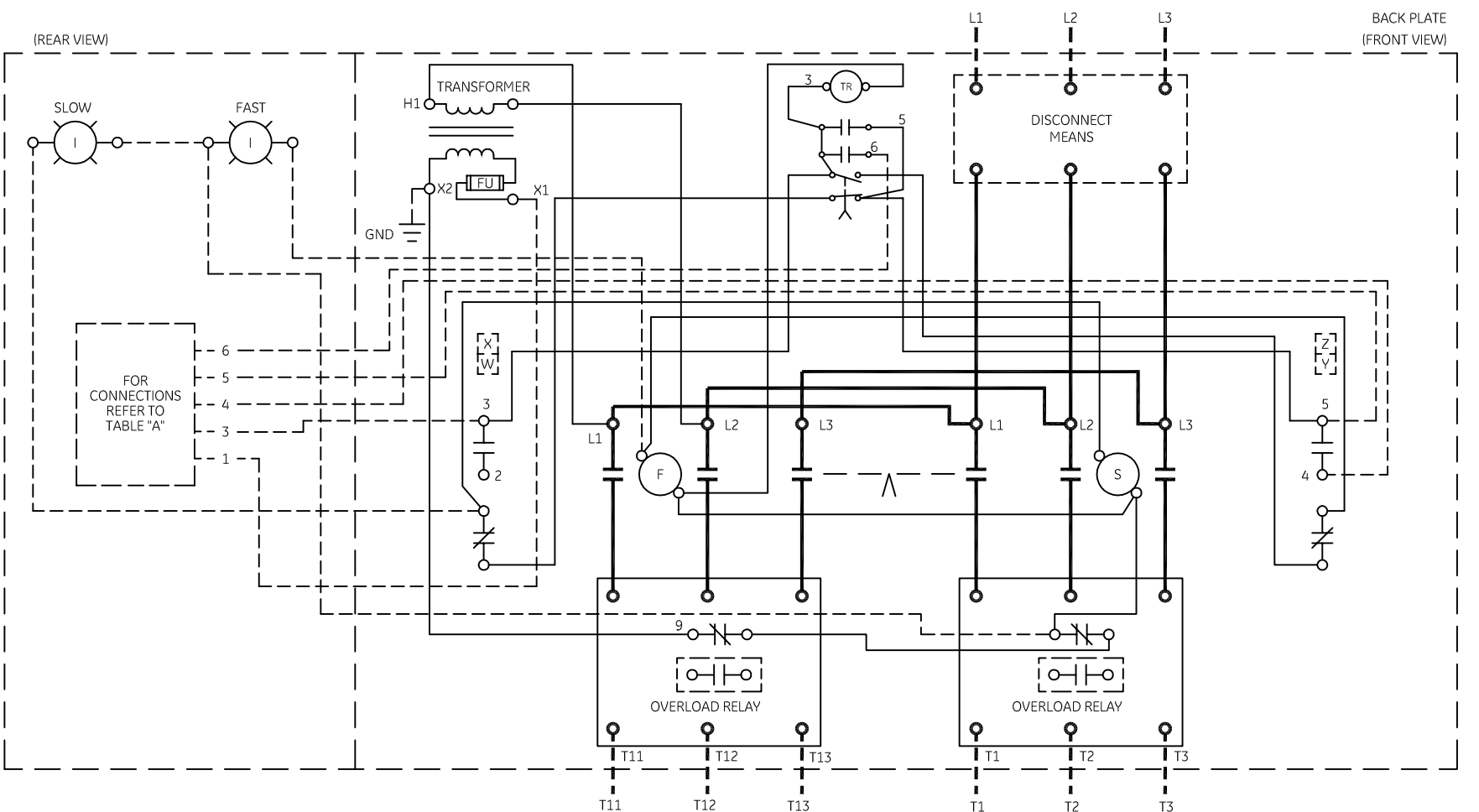
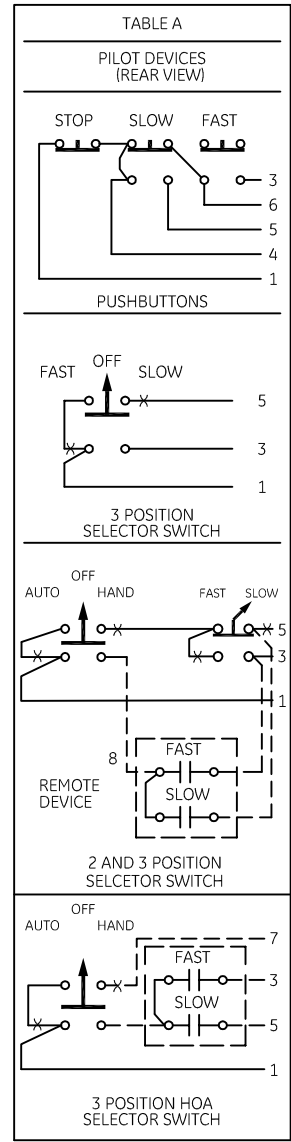

**GE** imagination at work

**WIRING DIAGRAM**  
 2 SPEED - 2 WINDING SIZE 2, 3 & 4

AN #	THIRD ANGLE PROJECTION	SHEET #	DWG NO.	DATE	REV
09-9115		1 OF 1	55-533880	09/07/2009	6