

-NOMENCLATURE-

F-FAST CONTACTOR
 S-SLOW CONTACTOR
 OL-THERMAL OVERLOAD RELAY
 I-INDICATING LIGHT
 FU-FUSE
 X-INDICATES CONTACT CLOSED
 A-ACCELERATING TIMER
 T.O.-TIME OPENING
 T.C.-TIME CLOSING
 ALTERNATE LEGENDS FOR FAST AND SLOW
 ARE HIGH AND LOW

NOTE: ADDITIONAL OVER-CURRENT PROTECTION
 MAY BE REQUIRED. REFER TO THE
 NATIONAL ELECTRICAL CODE OR LOCAL
 ELECTRICAL CODE AS REQUIRED.

FOR EXTRA AUXILIARY CONTACTS- A MAXIMUM OF 4
 CONTACTS MAY BE ADDED AT POSITIONS
 W,X,Y,& Z.

FOR CONTROLLER WITHOUT DISCONNECT MEANS-WIRE
 LINE DIRECT TO L1, L2 AND L3 ON CONTROLLER.

USE 75°C COPPER
 CONDUCTORS ONLY. FOR
 FIELD WIRING. TORQUE
 LINE AND LOAD TERMINALS
 AS SHOWN BELOW:

TERMINAL TIGHTENING TORQUE (LB-IN)

SIZE	LOAD SIDE		LINE SIDE		
	THERMAL OL	ELECTRONIC OL	CR309	CR310,390	CR311
2	50	20	50	AS MARKED	50
3	150	200	150	AS MARKED	50
4	200	200	200	AS MARKED	275

GROUND KIT

1/2-IN CONDUIT	55-213403G001
3/4-IN CONDUIT	55-213403G002
1-IN CONDUIT	55-213403G003
1 1/4-IN CONDUIT	55-213403G004
1 1/2-IN CONDUIT	55-213403G005
2-IN CONDUIT	55-213403G006
2 1/2-IN CONDUIT	55-213403G007
3-IN CONDUIT	55-213403G008

SELECTOR SWITCH

CONTACT	POSITION			
	FAST	SLOW	OFF	AUTO
A1				X
A2		X		
B1	X			
B2			X	

TABLE A

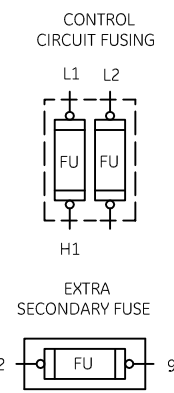
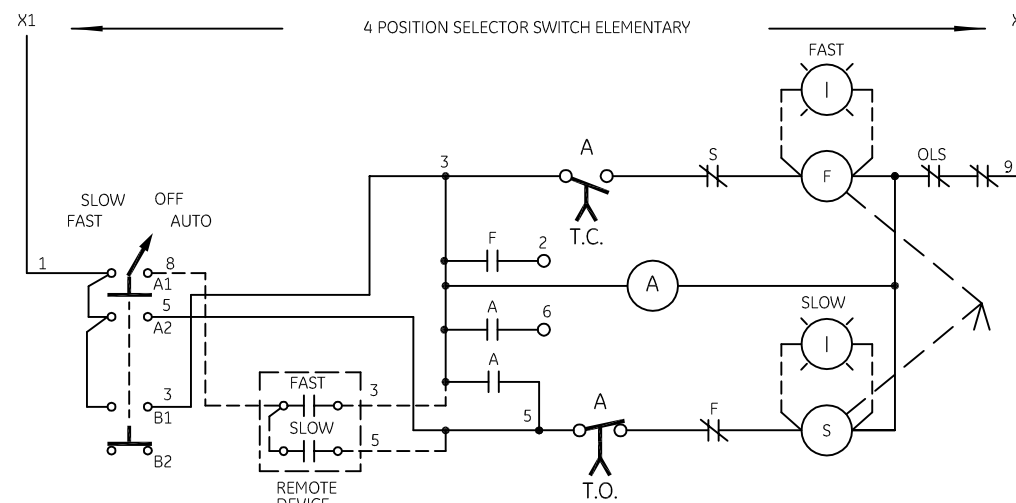
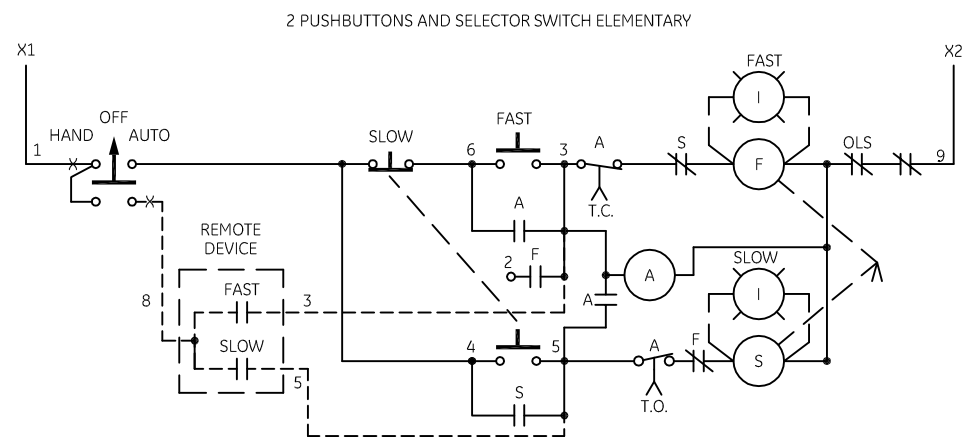
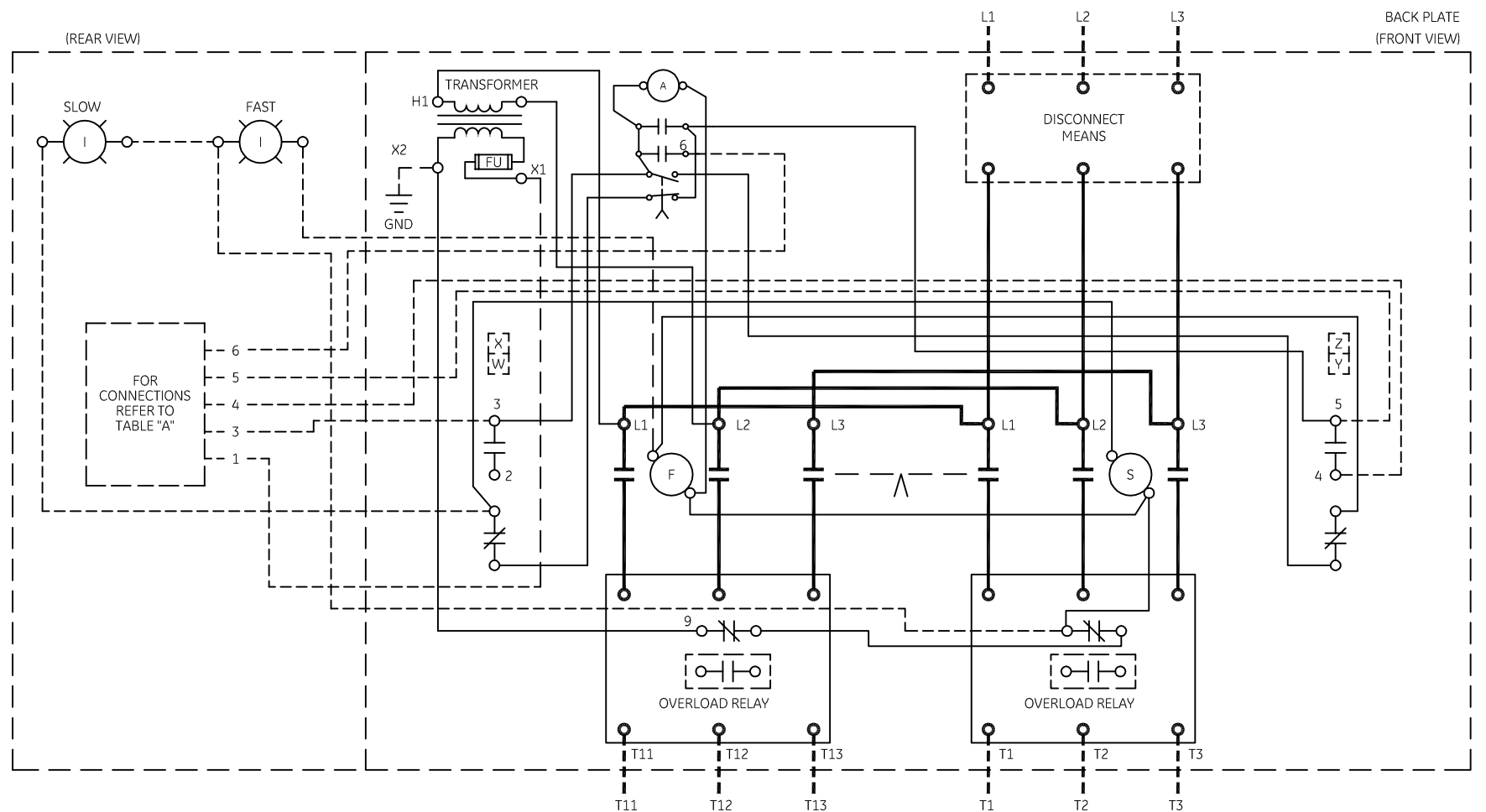
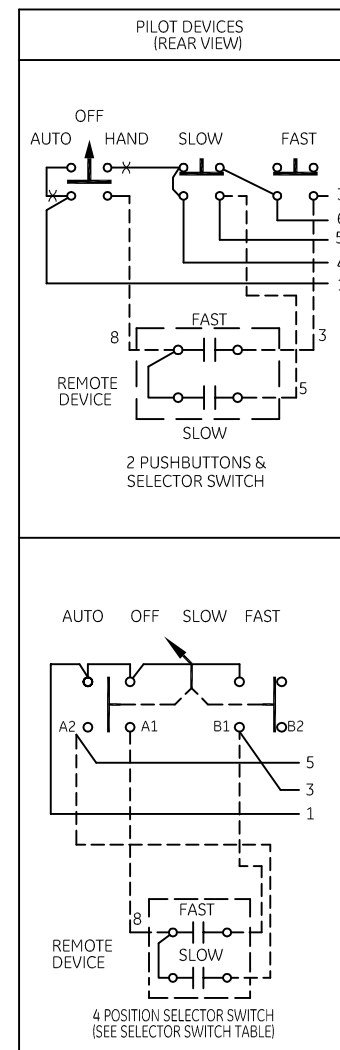

GE imagination at work

WIRING DIAGRAM
 2 SPEED - 2 WINDING SIZE 2, 3, 4 & 5

AN #	THIRD ANGLE PROJECTION	SHEET #	DWG NO.	DATE	REV
09-9115		1 OF 1	55-534791	09/15/2009	5