

-NOMENCLATURE-  
 1M,2M-CONTACTORS  
 OL-OVERLOAD RELAY  
 I-INDICATING LIGHT  
 FU-FUSE  
 X-INDICATES CONTACT CLOSED

ALTERNATE LEGENDS FOR FAST AND SLOW  
 ARE HIGH AND LOW

NOTE: ADDITIONAL OVER-CURRENT PROTECTION  
 MAY BE REQUIRED, REFER TO THE  
 NATIONAL ELECTRICAL CODE OR LOCAL  
 ELECTRICAL CODE AS REQUIRED.

FOR EXTRA AUXILIARY CONTACTS- A MAXIMUM OF 2  
 CONTACTS MAY BE ADDED AT POSITIONS  
 X & Z

FOR CONTROLLER WITHOUT DISCONNECT MEANS-WIRE  
 LINE DIRECT TO L1, L2 AND L3 ON CONTROLLER.

FACTORY SUPPLIED PILOT DEVICES ARE WIRED PER  
 TABLE "B". FOR CONSTANT HP MOTORS, CONSULT  
 FACTORY FOR ADDITIONAL INSTRUCTIONS

GROUND KIT		
1/2-IN CONDUIT	55-213403G001	
3/4-IN CONDUIT	55-213403G002	
1-IN CONDUIT	55-213403G003	
1 1/4-IN CONDUIT	55-213403G004	
1 1/2-IN CONDUIT	55-213403G005	
2-IN CONDUIT	55-213403G006	
2 1/2-IN CONDUIT	55-213403G007	
3-IN CONDUIT	55-213403G008	

MOTOR CONNECTIONS	SPEED	L1	L2	L3	OPEN	TOGETHER
CONSTANT HP	SLOW	T1	T2	T3	T1,T2,T3	T4,T5,T6
	FAST	T6	T4	T5		
CONSTANT TORQUE	SLOW	T1	T2	T3	T6,T4,T5	T1,T2,T3
	FAST	T6	T4	T5		
VARIABLE TORQUE	SLOW	T1	T2	T3	T6,T4,T5	T1,T2,T3
	FAST	T6	T4	T5		

CONNECTION TABLE	CONTROLLER TERMINALS					
	A	B	C	D	E	F
CONSTANT HP	T6	T4	T5	T1	T2	T3
CONSTANT TORQUE	T1	T2	T3	T6	T4	T5
VARIABLE TORQUE	T1	T2	T3	T6	T4	T5

TERMINAL TIGHTENING TORQUE (LB-IN)

SIZE	LOAD SIDE		LINE SIDE		
	THERMAL OL	ELECTRONIC OL	CR309	CR310,390	CR311
2	50	20	50	AS MARKED	50
3	150	200	150	AS MARKED	50
4	200	200	200	AS MARKED	275

USE 75°C COPPER  
 CONDUCTORS ONLY, FOR  
 FIELD WIRING. TORQUE  
 LINE AND LOAD TERMINALS  
 AS SHOWN AT RIGHT:

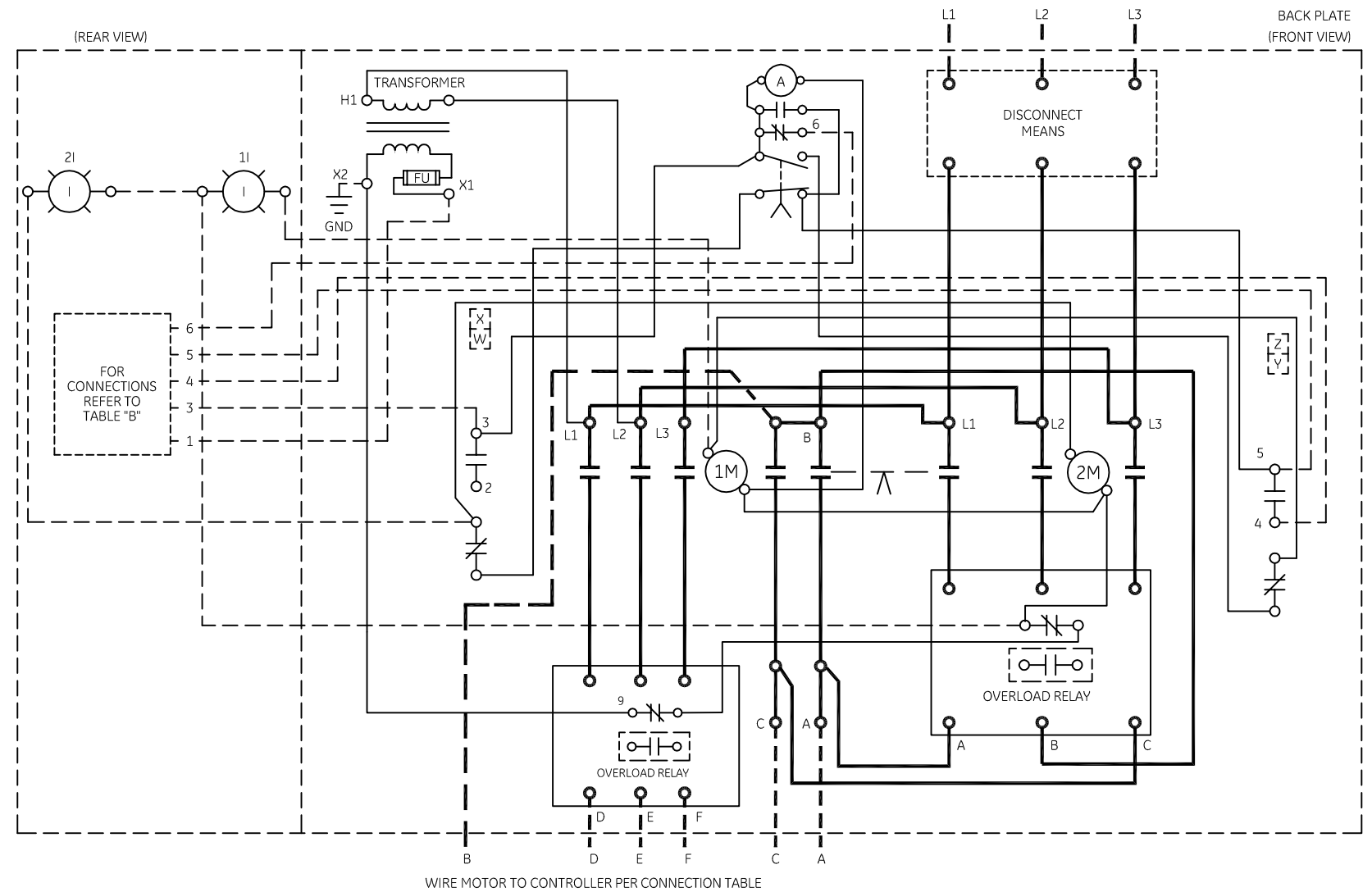
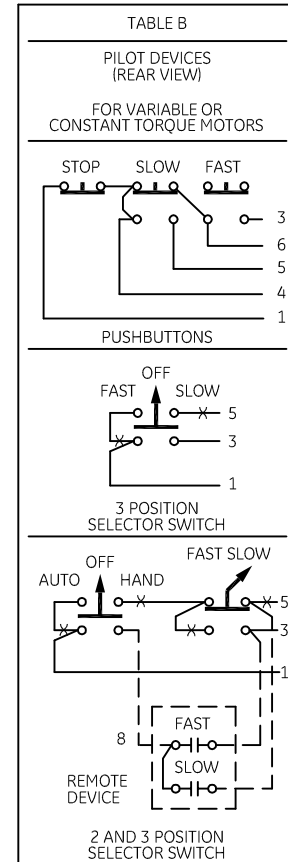
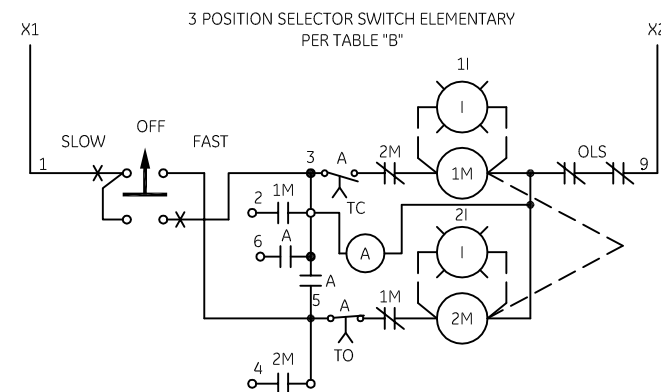
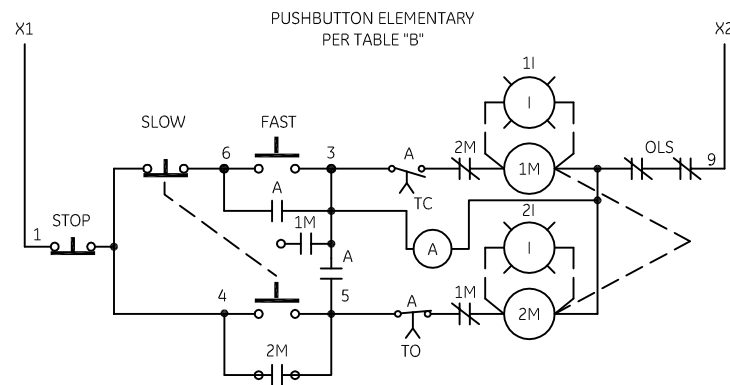

WIRE MOTOR TO CONTROLLER PER CONNECTION TABLE

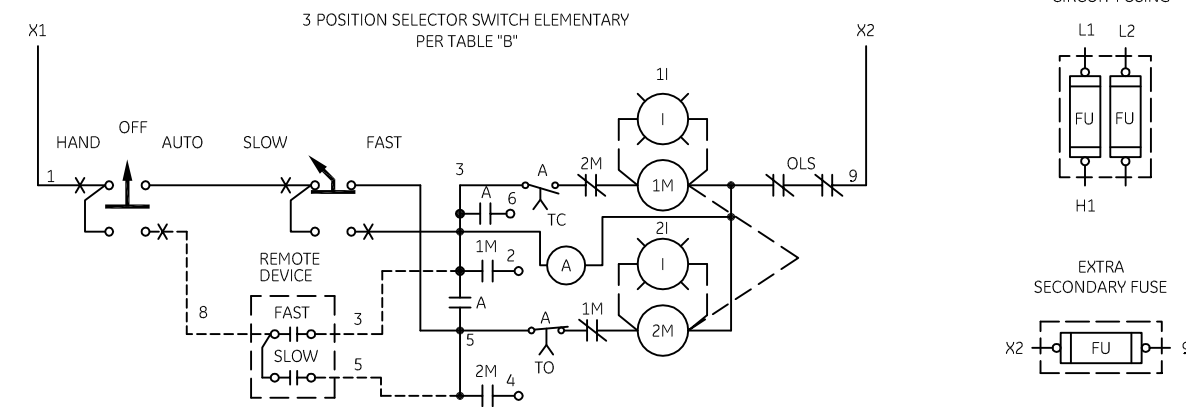

CONTROL CIRCUIT FUSING

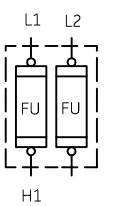

EXTRA SECONDARY FUSE

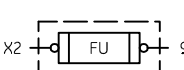

GE imagination at work

WIRING DIAGRAM  
 2 SPEED - 1 WINDING SIZE 2, 3 & 4

AN #	THIRD ANGLE PROJECTION	SHEET #	DWG NO.	DATE	REV
09-9115		1 OF 1	55-536054	09/08/2009	5