

REVISIONS			
REV.	DESCRIPTION	DATE	APPROVED
4	C077097	09/24/19	AR MAS

ATS POWER CIRCUIT SCHEMATIC

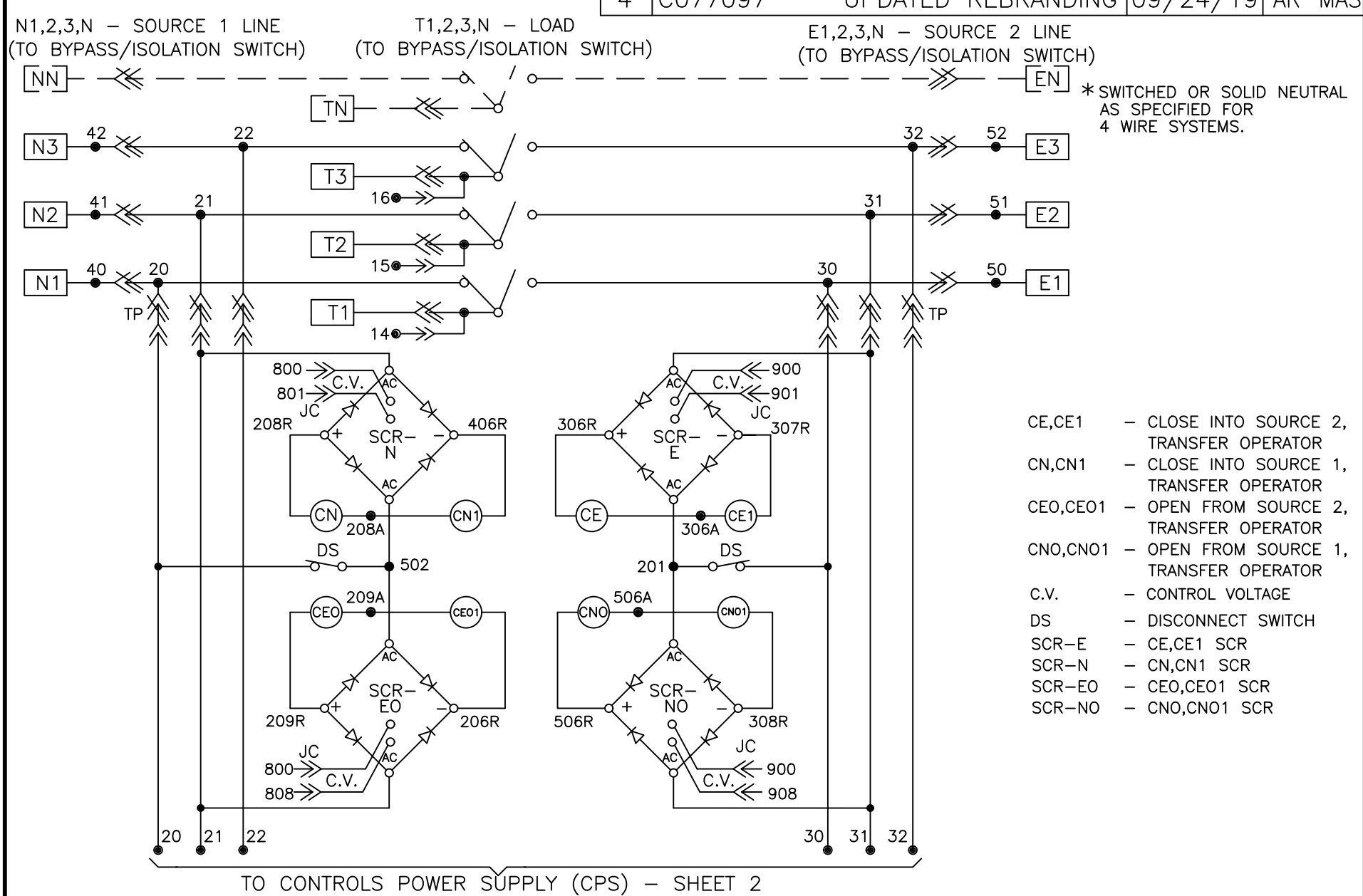

AUXILIARY CONTACTS

ATS POWER PANEL LAYOUT

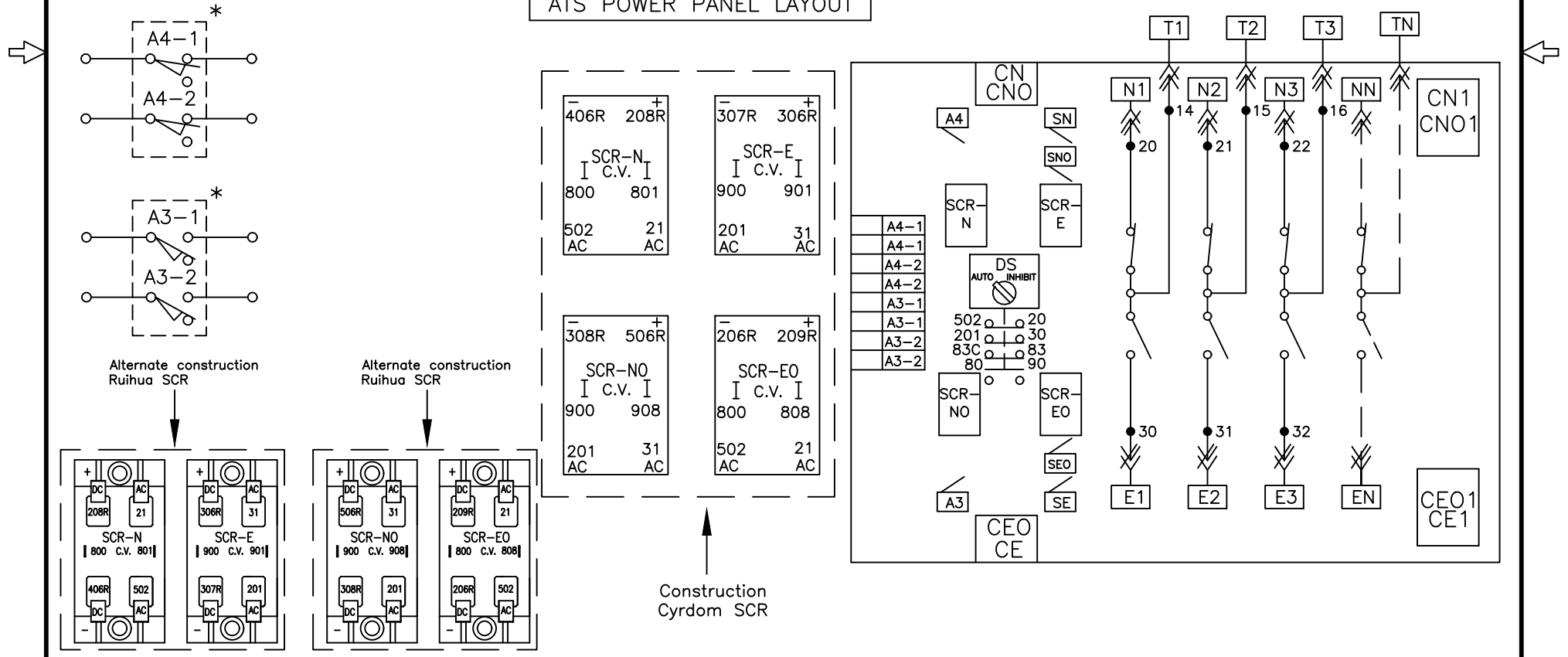

LIMIT SWITCH SCHEMATIC

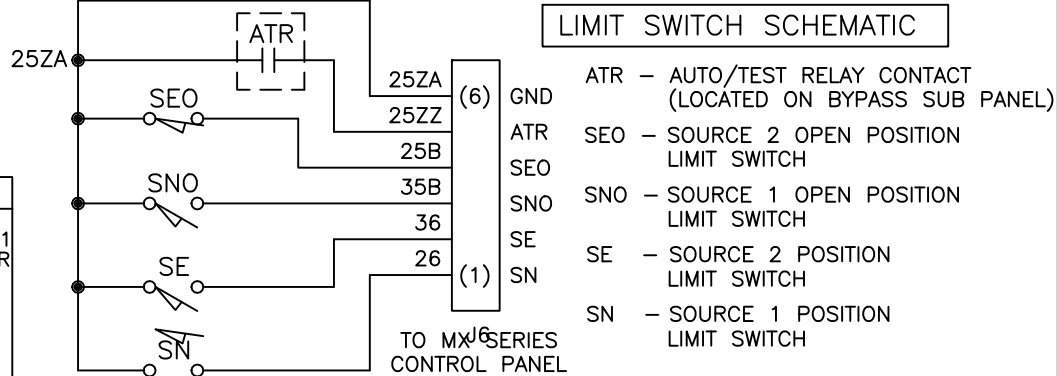

LEGEND	REFERENCE	NOTES
● WIRE CONNECTION	LEGEND, OPERATION, AND ACCESSORIES: 72A-0900D MX250 CONTROLLER-71A-0500	ATS SHOWN IN SOURCE 1 POSITION WITH NO POWER AVAILABLE.
○ WIRE ON TERMINAL BLOCK		
➤ WIRE IN INTERCONNECT PLUG		
* OPTIONAL		

<p>ABB PROPRIETARY AND CONFIDENTIAL INFORMATION</p> <p>The information contained in this document has to be kept strictly confidential. Any unauthorized use, reproduction, distribution or disclosure to third parties is strictly forbidden. ABB reserves all rights regarding intellectual Property Rights. Copyright 2018 ABB. All rights reserved</p> <p>THIRD ANGLE PROJECTION</p>	<p>FOR ADDITIONAL INFO REFER TO APPLIED PRACTICES UNLESS OTHERWISE SPECIFIED DIMENSIONS ARE IN INCHES</p> <p>TOLERANCES ON:  2 PL. DECIMALS ± .020  3 PL. DECIMALS ± .005  ANGLES ± 1°  FRACTIONS ± 1/64  FINISH ✓</p>	<p>SIGNATURES</p> <p>MODEL GG</p> <p>DATE 04/21/03</p> <p>CHECKED</p> <p>ENGRG FS</p> <p>MFG</p> <p>QUALITY</p> <p>ISSUED</p>	<p>TITLE</p> <p>ATS POWER CIRCUIT &amp; LAYOUT</p> <p>FIRST MADE FOR: ZBTSD(4000AMP)</p> <p>SIZE B CAGE CODE DWG NO 74A-4000</p>	
	<p>AutoCad Generated</p>	<p>DRAWING FILE: 74a-4000.dwg</p> <p>MODEL / ASSEMBLY FILE: ZBTSD(4000AMP)</p>	<p>SCALE: NA</p>	<p>SHEET 1 OF 5</p>
	<p># CTQs</p>	<p>CRITICAL TO QUALITY CHARACTERISTIC</p>	<p>ABB</p>	

CONTROLS POWER SUPPLY (CPS) SCHEMATIC

TO POWER CIRCUIT SCHEMATIC - SHEET 1

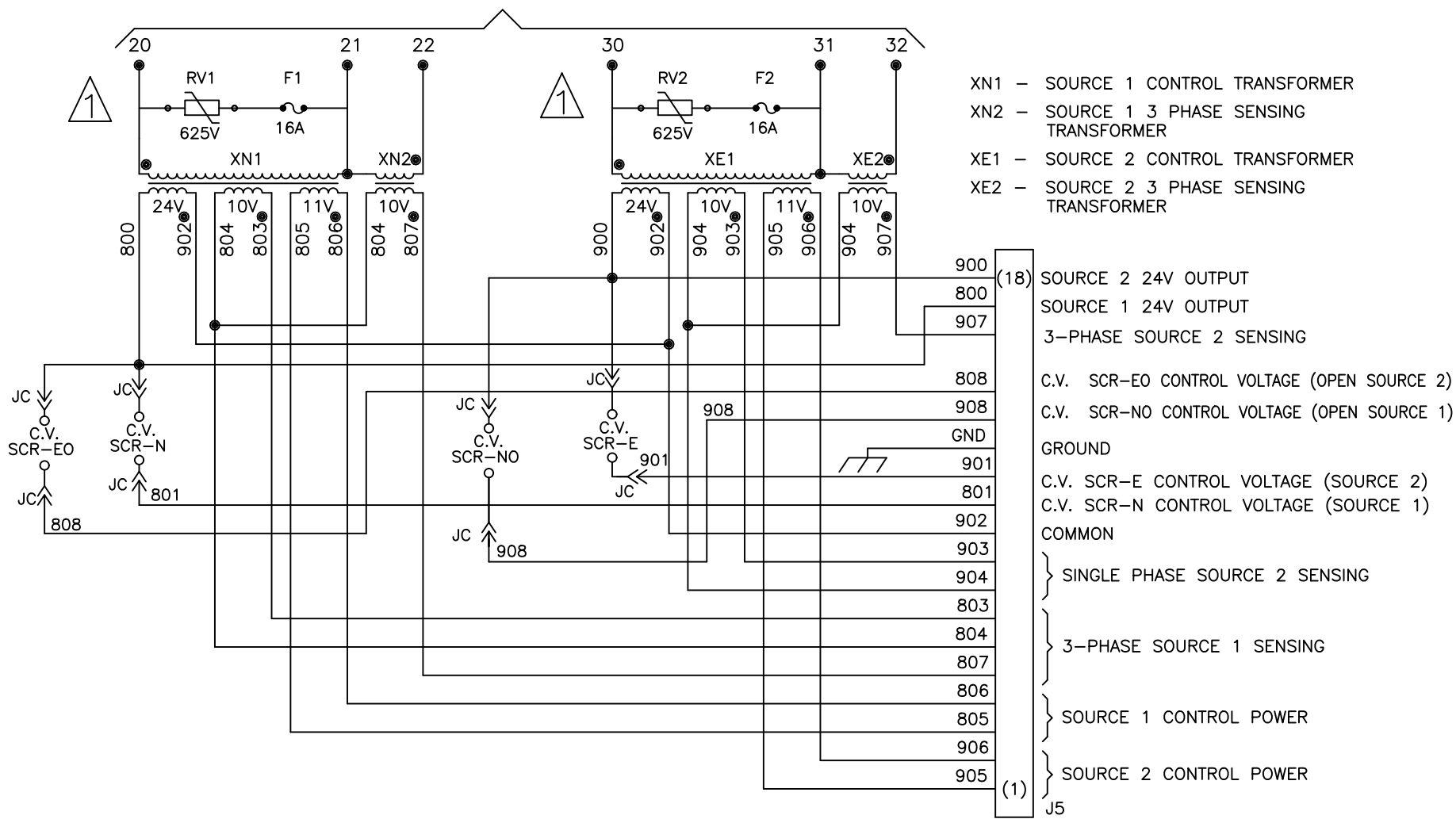

CONTROLS POWER SUPPLY (CPS)

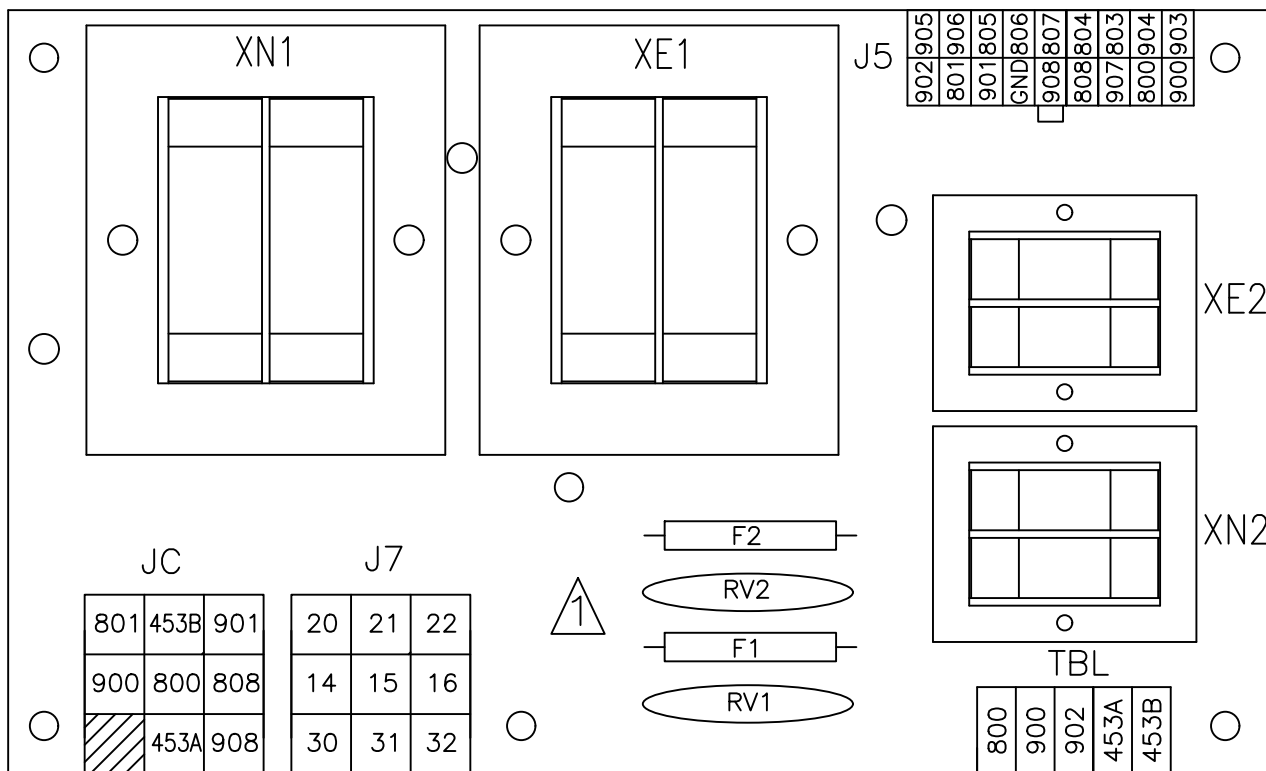

INTERCONNECT PLUGS

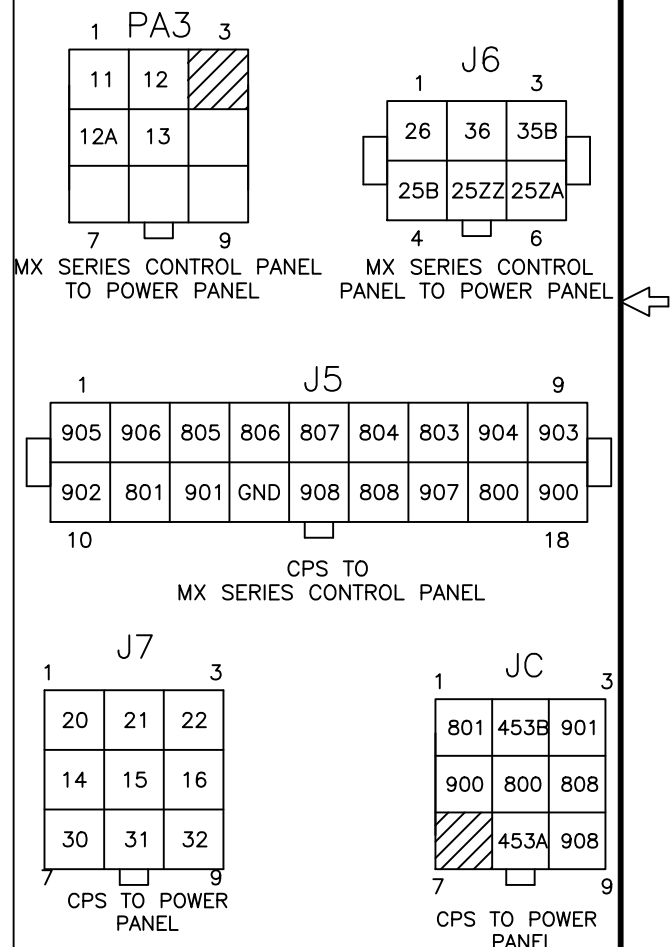

INTERCONNECT PLUG DIAGRAM

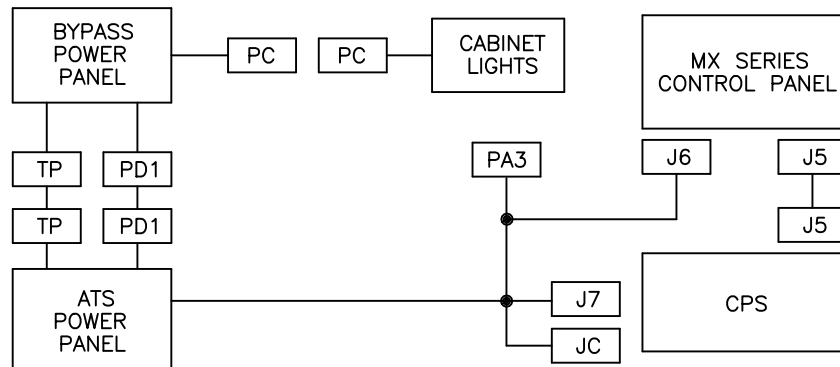

LEGEND

- WIRE CONNECTION
- \* OPTIONAL

ABB PROPRIETARY AND CONFIDENTIAL INFORMATION  
 The information contained in the document has to be kept strictly confidential.  
 Any unauthorized use, reproduction, distribution or disclosure to third parties is strictly forbidden.  
 ABB reserves all rights regarding intellectual Property Rights.  
 Copyright 2018 ABB. All rights reserved

THIRD ANGLE PROJECTION

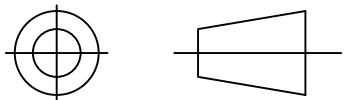

FOR ADDITIONAL INFO REFER TO APPLIED PRACTICES UNLESS OTHERWISE SPECIFIED DIMENSIONS ARE IN INCHES

TOLERANCES ON:  
 2 PL. DECIMALS ± .020  
 3 PL. DECIMALS ± .005  
 ANGLES ± 1°  
 FRACTIONS ± 1/64

FINISH ✓

SIGNATURES		DATE
MODEL	GG	05/05/03
DETAIL		
CHECKED		
ENGRG	FS	
MFG		
QUALITY		
ISSUED		
DRAWING FILE:	74a-2000.dwg	
MODEL / ASSEMBLY FILE:	ZBTSD(4000AMP)	
# CTQs	CRITICAL TO QUALITY CHARACTERISTIC	



TITLE  
 CONTROLS POWER SUPPLY(CPS)  
 & INTERCONNECT PLUGS

FIRST MADE FOR: ZBTSD(4000AMP)

SIZE CAGE CODE DWG NO

B 74A-4000

SCALE: NA

SHEET 2 OF 5

AutoCad Generated

↓

**OPERATION: BYPASS/ISOLATION SWITCH**

**AUTOMATIC**

1. Manually operated Bypass Switch contacts (BN/BE) are open and ATS is supplying load.
2. Disconnect Switch (DS) is in "AUTO".

**TO BYPASS ATS**

1. Open bottom cabinet door and turn DS to "INHIBIT".
2. Turn Bypass Selector Switch (BSS) to same power source as ATS.
3. Move the Manual Bypass Handle (MBH) upward.

**TO TEST ATS**

1. Bypass per above instructions.
2. Rotate crank mechanism counterclockwise until ATS TEST light is illuminated.
3. Turn DS to "AUTO".
4. Test Switch (TS) on bottom cabinet door will allow electrical operation of ATS.

**TO ISOLATE ATS**

1. Bypass per above instructions.
2. Rotate crank mechanism counterclockwise until ATS ISOLATED light is illuminated.

**TO REMOVE ATS**

1. Bypass and Isolate per above instructions.
2. Disconnect multipin plugs and external connections to ATS.
3. Slide four corner latches of ATS to innermost position.
4. ATS can now be removed from cabinet.

**TO RECONNECT ATS**

1. Roll cart back into cabinet.
2. Slide four corner latches of ATS to outermost position.
3. Turn DS Switch to "INHIBIT".
4. Manually position ATS into same source as Bypass Switch.
5. Reconnect multipin plugs and external connections to ATS.
6. Rotate crank mechanism clockwise until ATS TEST light is illuminated.
7. Turn DS Switch to "AUTO" and use TS to electrically operate ATS.
8. Turn DS to "INHIBIT".
9. Rotate crank mechanism clockwise until ATS location pointer is aligned with "AUTO" mark on location indicator. (ATS must be in same source as Bypass).
10. Turn DS to "AUTO" and open Bypass with MBH.
11. ATS is now fully automatic (Figure 1).

**NOTES:**

1. DS in "INHIBIT" will prevent ATS electrical operation.
2. DO NOT use excessive force on mechanical handles.
3. Above Figures depict Bypass SOURCE 1. Sequence is same for Bypass SOURCE 2.
4. When ATS is in TEST or ISOLATE, Bypass Switch is a manual transfer switch to either available source. (Indicated on light panel).
5. To operate Bypass when ATS is in TEST or ISOLATE:
  - a) Move MBH downward (to open Bypass Contacts BN/BE).
  - b) Turn BSS to opposite power source.
  - c) Move MBH upward to close into selected power source.

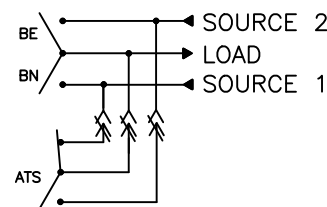

FIG. 1 BP IS OPEN WITH ATS IN SOURCE 1

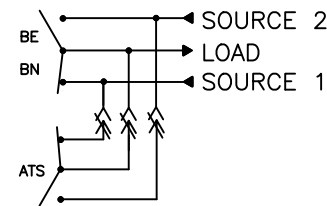

FIG. 2 BP IN SOURCE 1 WITH ATS IN SOURCE 1

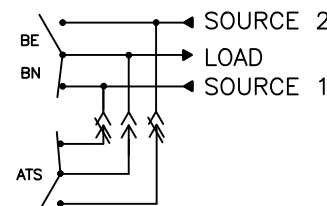

FIG. 3 BP IN SOURCE 1 WITH ATS IN TEST (LOAD CONNECTIONS ARE OPEN)

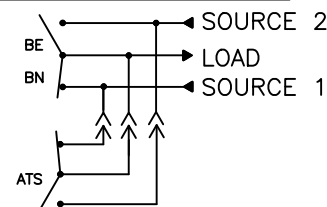

FIG. 4 BP IN SOURCE 1 WITH ATS ISOLATED

**NOTES:**

1. BP—Bypass switch (indicated by contacts BN/BE) is a 3 position switch.
2. ATS—Automatic Transfer Switch.

LEGEND: BYPASS/ISOLATION SWITCH (BP)

**I. (BP) BYPASS/ISOLATION SWITCH: MECHANICAL COMPONENTS**

- N1,2,3(N).....SOURCE 1 Line connections.....
- E1,2,3(N).....Bypass SOURCE 2 contacts
- T1,2,3(N).....Bypass SOURCE 1 contacts
- BE.....Bypass Selector Switch
- BN.....SOURCE 2 Line connections.....
- BSS.....Manual Bypass Handle
- MBH.....Load Line connections.....

**II. (BP) BYPASS/ISOLATION: ELECTRICAL COMPONENTS**

- AA-1,2.....Limit switch held actuated in Auto location of ATS, Non-actuated Test and Isolated locations.
- AB3-1,2,3,4.....Limit switch, actuated in Bypass SOURCE 2 position
- AB4-1,2.....Limit switch, actuated in Bypass SOURCE 1 position
- AE-1,2.....Limit switch, switches Engine Start from ATS control to bypass control during ATS Isolate
- AI-1,2.....Limit switch, actuated in Isolate location
- AT-1,2.....Limit switch, actuated in Test location
- ATR.....Auto/Test Relay. Energized in AUTO and TEST locations
- BR-1,2,3.....Bridge Rectifier
- C.....Capacitor: RNH
- CBC.....Crank Solenoid
- CBE.....SOURCE 2 Bypass Permissive Solenoid
- CBN.....SOURCE 1 Bypass Permissive Solenoid
- CH-1.....Limit switch actuated when crank handle is engaged
- D1.....Diode
- R1.....Resistor: RNH
- RNH.....Relay normally held, 24 VDC coil, 3PDT
- XBE.....SOURCE 2 line control transformer
- XBN.....SOURCE 1 line control transformer

**III. (BP) BYPASS/ISOLATION SWITCH: INDICATOR LIGHTS**

- LNA.....SOURCE 1 available
- LEA.....SOURCE 2 available
- LBN (NOTE 1).....Bypass SOURCE 1 (BN closed)
- LBE (NOTE 1).....Bypass SOURCE 2 (BE closed)
- LIT (NOTE 1).....ATS DS switch in INHIBIT position
- LDS (NOTE 1).....ATS in Test location
- LAT (NOTE 1).....ATS in Isolate location
- LAI (NOTE 1).....ATS Inhibit

**NOTES:**

1. Indicator off during automatic operation of ATS.
2. Four pole includes neutral lugs.

ABB PROPRIETARY AND CONFIDENTIAL INFORMATION  The information contained in the document has to be kept strictly confidential. Any unauthorized use, reproduction, distribution or disclosure to third parties is strictly forbidden. ABB reserves all rights regarding intellectual Property Rights. Copyright 2018 ABB. All rights reserved.	FOR ADDITIONAL INFO REFER TO APPLIED PRACTICES UNLESS OTHERWISE SPECIFIED DIMENSIONS ARE IN INCHES	SIGNATURES MODEL GG DETAIL	DATE 04/21/03	<p style="font-size: 24px; font-weight: bold; margin: 0;">BYPASS ISOLATION LEGEND &amp; OPERATION</p>
	TOLERANCES ON: 2 PL. DECIMALS ± .020 3 PL. DECIMALS ± .005 ANGLES ± 1° FRACTIONS ± 1/64  FINISH ✓	CHECKED ENGRG FS MFG QUALITY ISSUED	DRAWING FILE: 74a-4000.dwg MODEL / ASSEMBLY FILE: ZBTSD(4000AMP)	
THIRD ANGLE PROJECTION  	AutoCad Generated	# CTQs CRITICAL TO QUALITY CHARACTERISTIC	SCALE: NA	SHEET 3 OF 5





**BYPASS/ISOLATION SCHEMATIC**

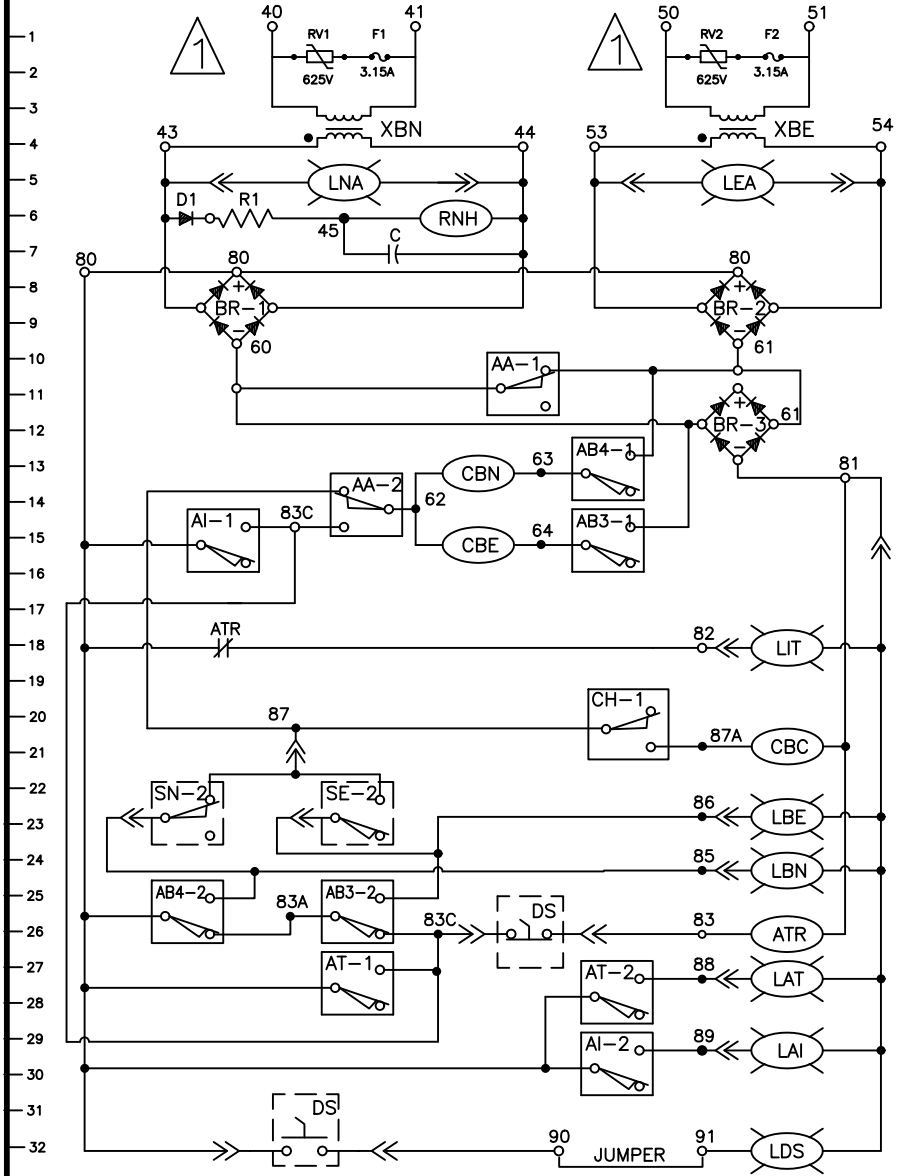

- XBN - BYPASS SOURCE 1 CONTROL TRANSFORMER
- XBE - BYPASS SOURCE 2 CONTROL TRANSFORMER
- LNA - SOURCE 1 AVAILABLE LIGHT
- LEA - SOURCE 2 AVAILABLE LIGHT
- RNH - NORMALLY HELD RELAY
- D1 - DIODE
- R1 - RESISTOR, RNH
- C - CAPACITOR, RNH
- BR-1,2,3 - BRIDGE RECTIFIER
- AA-1 - LIMIT SWITCH, ATS AUTO LOCATION
- AB4-1 - LIMIT SWITCH, BYPASS SOURCE 1
- CBN - SOURCE 1 TRANSFER OPERATOR
- AA-2 - LIMIT SWITCH, ATS IN AUTO
- AB3-1 - LIMIT SWITCH, BYPASS SOURCE 2
- CBE - SOURCE 2 TRANSFER OPERATOR
- LIT - ATS INHIBIT LIGHT
- AI-1 - LIMIT SWITCH, ATS IN ISOLATE
- CH-1 - LIMIT SWITCH
- CBC - CRANK SOLENOID
- LBE - LIGHT, BYPASS SOURCE 2
- LBN - LIGHT, BYPASS SOURCE 1
- AB4-2 - LIMIT SWITCH, BYPASS SOURCE 1
- AB3-2 - LIMIT SWITCH, BYPASS SOURCE 2
- ATR - AUTO/TEST RELAY
- AT-1 - LIMIT SWITCH, ATS TEST LOCATION
- LAT - ATS TEST LOCATION
- AT-2 - LIMIT SWITCH, ATS IN TEST
- LAI - ATS ISOLATE LIGHT
- AI-2 - LIMIT SWITCH, ATS IN ISOLATE
- DS - ATS DISCONNECT SWITCH
- LDS - DISCONNECT SWITCH, INHIBIT POSITION LIGHT

**600V SPD ASSEMBLY SCHEMATIC**

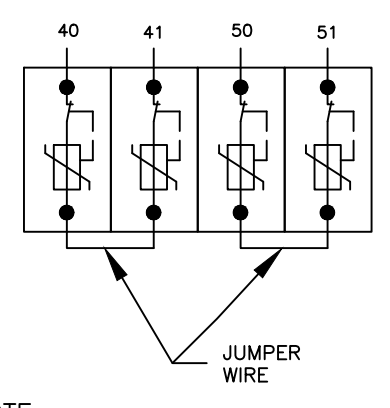

NOTE: SPD INPUT SIGNALS TO BE WIRED FROM BYPASS SUBPANEL

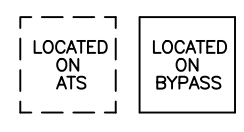

**ENGINE START SCHEMATIC**

**ENGINE START CIRCUIT**

- AE-1,2 - LIMIT SWITCH, ENGINE START TRANSFER
- AB3-3,4 - LIMIT SWITCH, BYPASS SOURCE 2

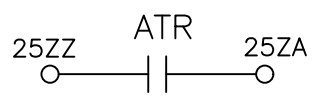

SOURCE 1/SOURCE 2 TRANSFER PERMIT CIRCUIT. (ALH IN AUTO AND TEST LOCATION WITH DS IN AUTO POSITION)

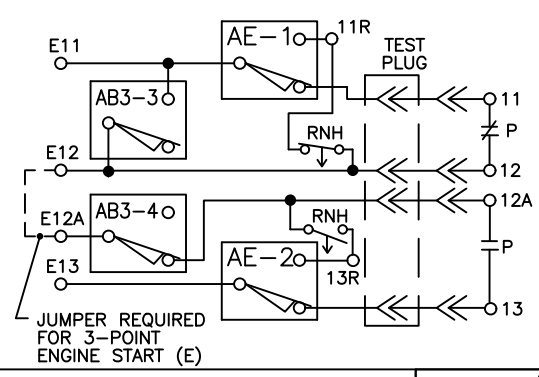

JUMPER REQUIRED FOR 3-POINT ENGINE START (E)

**LIMIT SWITCH CHART**

X = ACTUATED	ATS LOCATION				ATS MODE		BYPASS MODE	
	AUTO	TEST	ISO	REMOVE	SOURCE 1	SOURCE 2	SOURCE 1	SOURCE 2
AA	X							
AT		X						
AI			X	X				
AE			X	X				
SN					X			
SE						X		
AB4							X	
AB3								X

**BYPASS SUBPANEL**

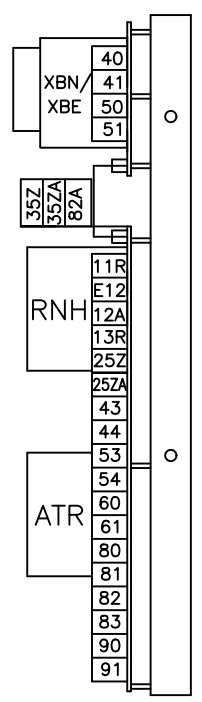

**NOTES**

ATS SHOWN IN SOURCE 1 POSITION WITH NO POWER AVAILABLE.

**LEGEND**

- WIRE CONNECTION
- WIRE ON TERMINAL BLOCK
- ⇒ WIRE IN INTERCONNECT PLUG

REFER TO SHEET 2 FOR INTERCONNECT PLUG DIAGRAM

**ATS TEST PLUG (TP)**

LOOKING AT PINS

LOOKING AT SOCKETS

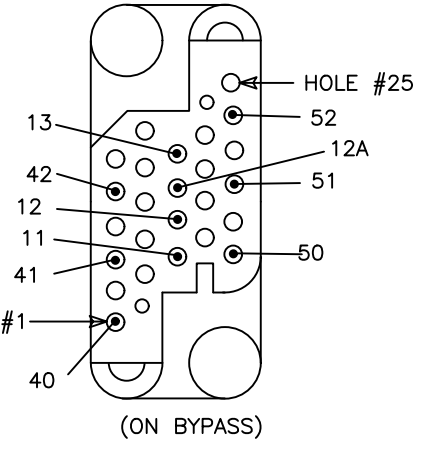
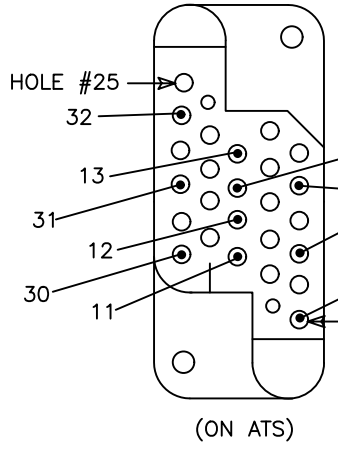

PD1

PC



ABB PROPRIETARY AND CONFIDENTIAL INFORMATION  
The information contained in this document has to be kept strictly confidential. Any unauthorized use, reproduction, distribution or disclosure to third parties is strictly forbidden.  
ABB reserves all rights regarding intellectual Property Rights. Copyright 2018 ABB. All rights reserved.

THIRD ANGLE PROJECTION



FOR ADDITIONAL INFO REFER TO	SIGNATURES	DATE
APPLIED PRACTICES	MODEL GG	04/21/03
UNLESS OTHERWISE SPECIFIED DIMENSIONS ARE IN INCHES	DETAIL	
TOLERANCES ON:	CHECKED	
2 PL. DECIMALS ± .020	ENGRG FS	
3 PL. DECIMALS ± .005	MFG	
ANGLES ± 1°	QUALITY	
FRACTIONS ± 1/64	ISSUED	
FINISH	DRAWING FILE: 74a-4000.dwg	FIRST MADE FOR: ZBTSD(4000AMP)
AutoCad Generated	MODEL / ASSEMBLY FILE: ZBTSD(4000AMP)	SIZE B CAGE CODE DWG NO
	# CTQs	74A-4000
	CRITICAL TO QUALITY CHARACTERISTIC	SHEET 4 OF 5

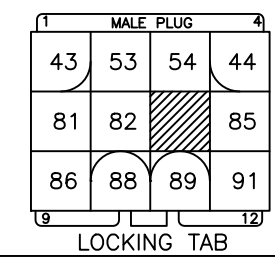
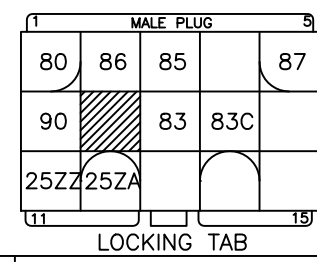
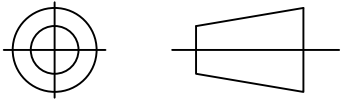

**BYPASS ISOLATION SCHEMATIC & PLUGS**

SCALE: NA



# BYPASS/ISOLATION TRANSFER SWITCH

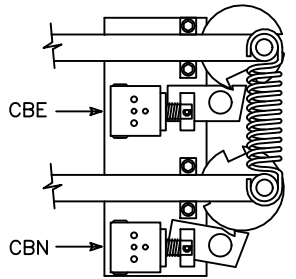

VIEW "A"

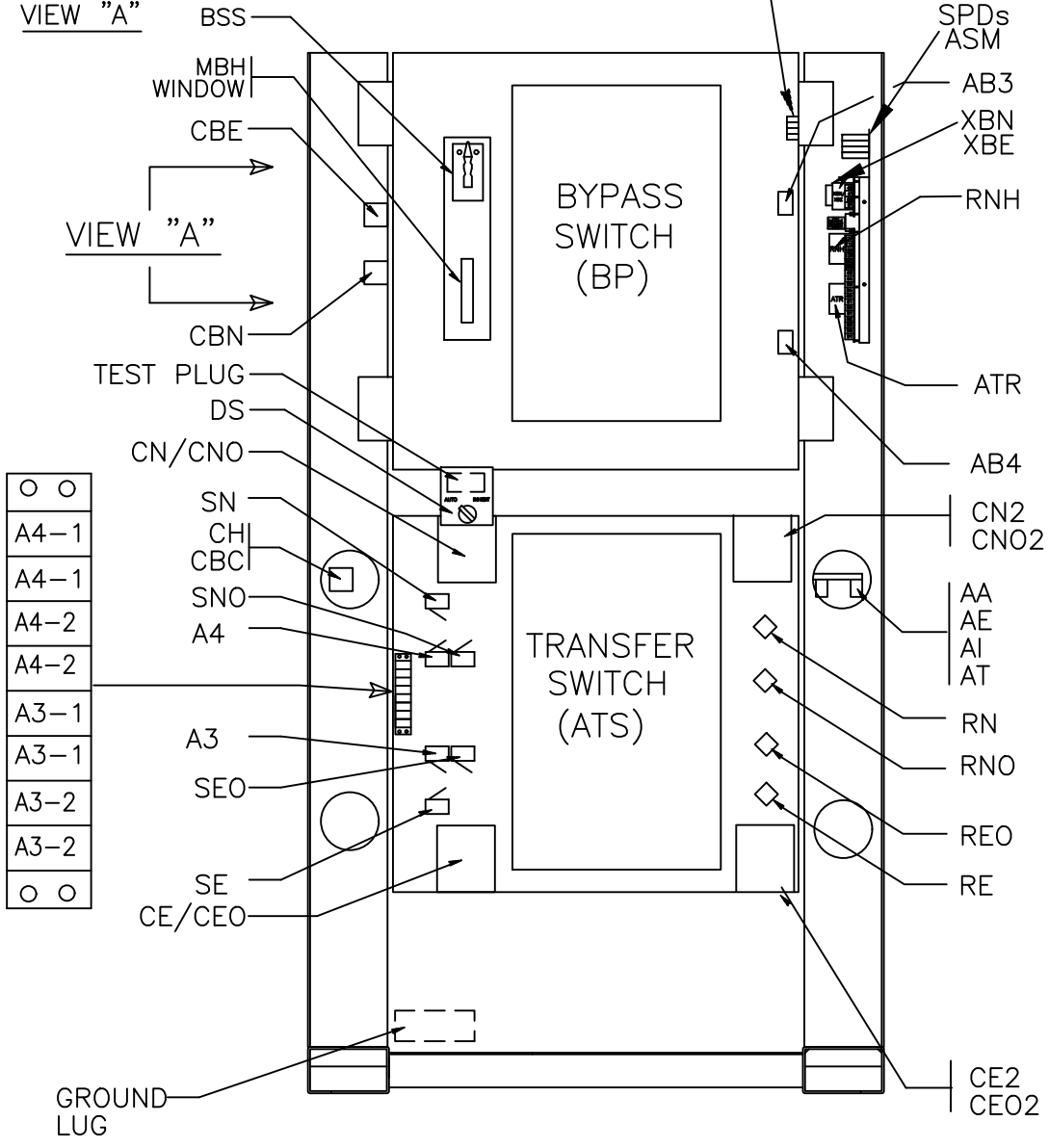

- ○
- E11
- E12
- E12A
- E13
- ○

WIRE NUMBERING CHART

LIMIT SWITCHES	C	NC	NO
AA-1	60		61
AA-2	62	83C	87
AB3-1	64		60
AB3-2	83A	83C	86
AB3-3	E12		E11
AB3-4	E12A	12A	
AB4-1	63		61
AB4-2	80	83A	85
AE-1	E11	11	11R
AE-2	E13	13	13R
AI-1	80		83C
AI-2	80		89
AT-1	80		83C
AT-2	80		88
CH-1	87	87A	
SE-2	86		87
SN-2	85		87

- ○
- A4-1
- A4-1
- A4-2
- A4-2
- A3-1
- A3-1
- A3-2
- A3-2
- ○

STANDARD LUG CONFIGURATION  
(CONSULT FACTORY FOR OPTIONAL CONFIGURATIONS)  
REAR VIEW OF ENCLOSURE

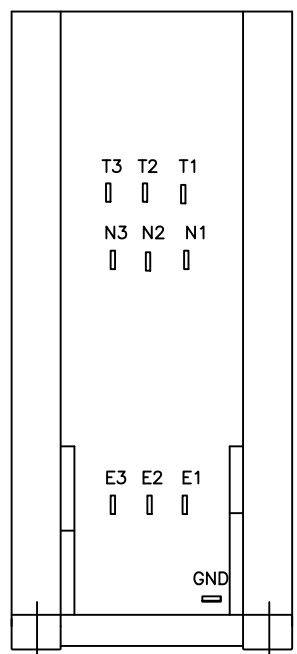

2/3-POLE SWITCH

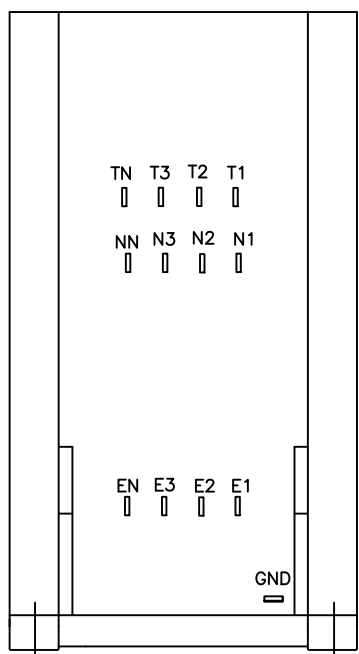

4-POLE SWITCH

BYPASS/ISOLATION DIAGRAM

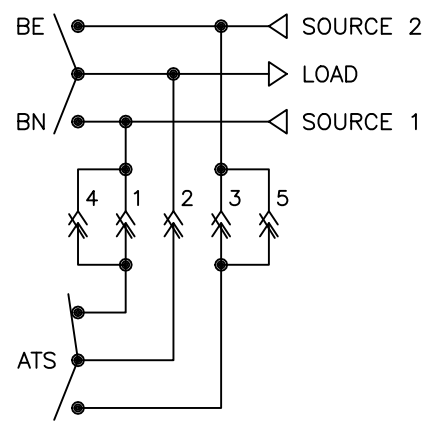

ATS LOCATION	LOAD CARRYING CONTACTS			ATS TEST PLUG (TP)	
	1	2	3	4	5
AUTO	X	X	X	X	X
TEST	0	0	0	X	X
ISOLATE	0	0	0	0	0

X = CLOSED  
0 = OPEN

NOTES

ATS SHOWN IN SOURCE 1 POSITION WITH NO POWER AVAILABLE.

ABB PROPRIETARY AND CONFIDENTIAL INFORMATION  
The information contained in this document has to be kept strictly confidential.  
Any unauthorized use, reproduction, distribution or disclosure to third parties is strictly forbidden.  
ABB reserves all rights regarding intellectual Property Rights.  
Copyright 2018 ABB. All rights reserved

THIRD ANGLE PROJECTION

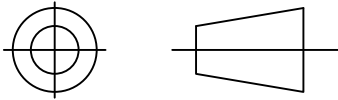

FOR ADDITIONAL INFO REFER TO	SIGNATURES	DATE
APPLIED PRACTICES	MODEL GG	04/21/03
UNLESS OTHERWISE SPECIFIED DIMENSIONS ARE IN INCHES	DETAIL	
TOLERANCES ON:	CHECKED	
2 PL. DECIMALS ± .020	ENGRG FS	
3 PL. DECIMALS ± .005	MFG	
ANGLES ± 1°	QUALITY	
FRACTIONS ± 1/64	ISSUED	
FINISH	DRAWING FILE: 74a-4000.dwg	SIZE B
AutoCad Generated	MODEL / ASSEMBLY FILE: ZBTSD(4000AMP)	CAGE CODE
	# CTQs	DWG NO
	CRITICAL TO QUALITY CHARACTERISTIC	



## BYPASS ISOLATION TRANSFER SWITCH

FIRST MADE FOR: ZBTSD(4000AMP)	SCALE: NA	SHEET 5 OF 5
74A-4000		