



# Power Express RRH

150044533  
J2015003L001



Read and follow all safety statements, warnings, and precautions in this guide.  
Provide unrestricted front to rear air flow—minimum 3 inches behind the shelf.  
Capacitive jumper required at each load

**Tools required:**  
Cable crimpers      Torque wrench (0-240 in-lb / 28 Nm)      Sockets - 5/16," 7/16" and 1/2"  
Screw Drivers - Flat & 2 Phillips      Wire cutters and strippers

## Step 1 - Mount Shelf

1. Ensure the frame/rack is properly bounded.
2. Attach the system to the frame/rack using a minimum of 4 (two on each side) 12-24 screws (provided).  
Torque to 35 in-lb - 5/16" socket.

## Step 2 - Connect Chassis Ground

- Wire - 6AWG minimum
- Lug - double-hole #10 on 5/8" centers (not provided).
- Secure lug with screws - 10-32 (provided)  
Torque to 10-32 screws to 30 in-lb (3.4Nm) - 5/16" socket.

Some applications may rely on frame mounting screws for shelf ground omitting the shelf ground cable.

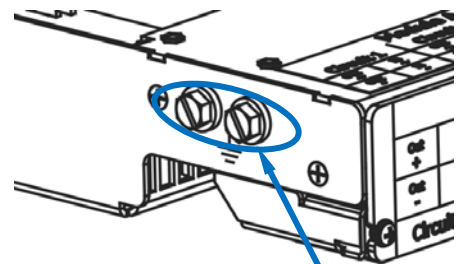

Chassis Ground

## Step 3 - Connect DC Inputs

Connections are on the rear behind a cover - 2 screws.

- Wire - 6 AWG
- Recommended external feed protectors - 50A
- Lug - single-hole #10 (not provided).
- Connect **In-** and **In+** wires to each circuit of each module.  
Connect **In-** wire before **In+** wire.

Secure lug with screws - 10-32 (provided)  
Torque to 30 in-lb (3.4Nm) - 5/16" socket.

**Note:** In+ and Out + wires must be connected to DC Reference Ground (CO Ground).

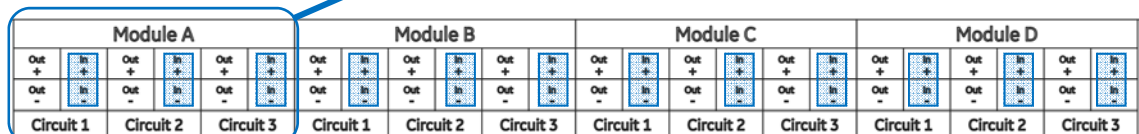
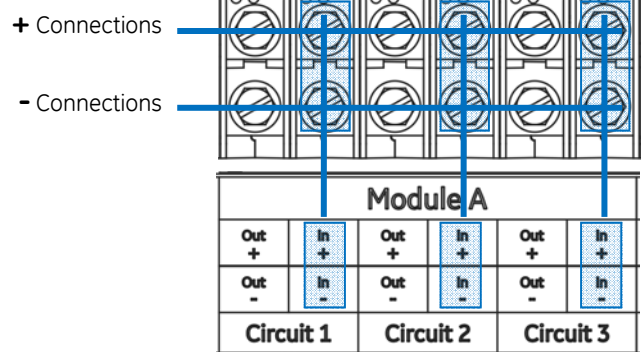

### Step 4 - Verify DC Input Voltage and Polarity

- Verify that the DC Input voltage is -48VDC and matches the marked polarity using a meter on each **In+** and **In-**.

### Step 5 - Connect DC Outputs

Connections are on the rear behind a cover - 2 screws.

- Wire - 6 or 8 AWG
- Lug - single-hole #10 (not provided).
- Connect **Out-** and **Out+** wires to each circuit of each module. Connect **Out-** wire before **Out+** wire.

Secure lug with screws - 10-32 (provided)  
Torque to 30 in-lb (3.4Nm) - 5/16" socket.

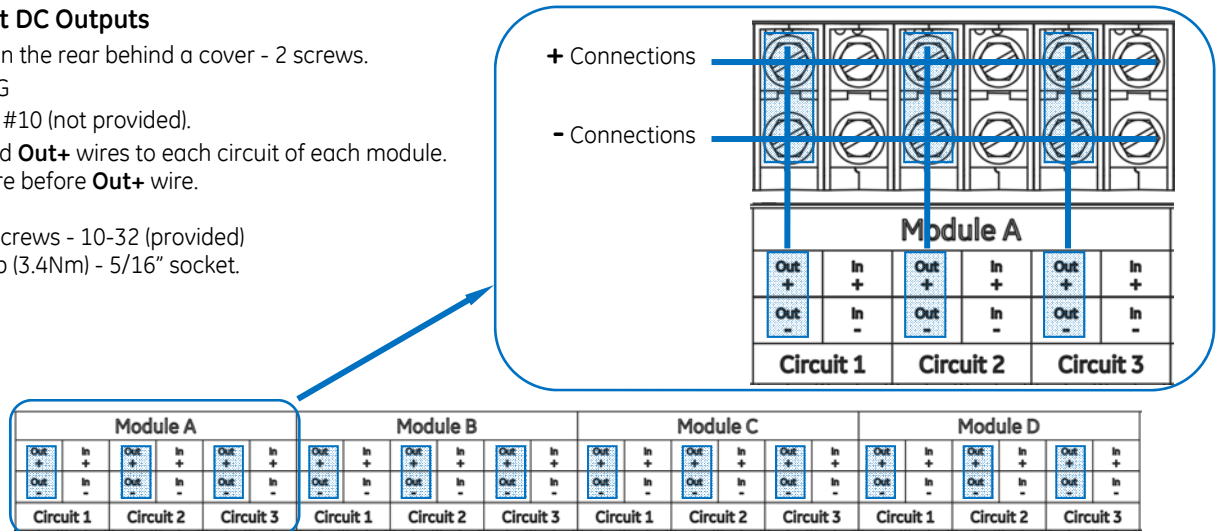

### Step 6 - Connect Alarm Cable

1. Remove alarm connectors from the chassis.
2. Connect alarm cable.
3. Insert alarm connector into the chassis.

1. Strip wire 3/16"
2. Insert wire fully into wire entry
3. Tighten screw

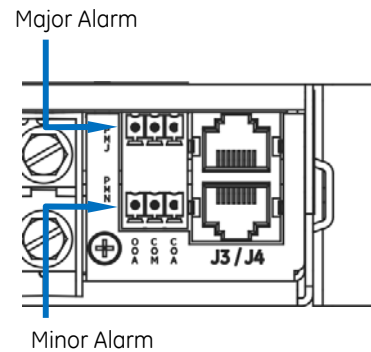
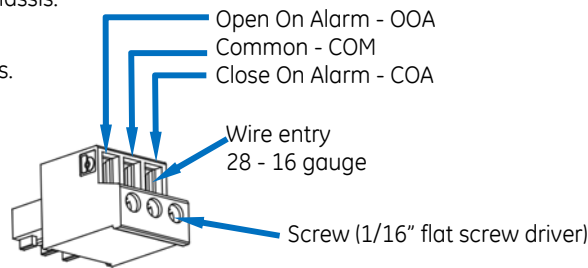

- Warning:** Shock Hazard and Equipment Damage - Equipment and subassembly ports
1. are suitable for connection to intra-building or unexposed wiring or cabling;
  2. can be connected to shielded intra-building cabling grounded at both ends.

### Step 7 - Verify Shelf ID Setting

ID Switch is on the left side near the rear.  
Down is 0.

- Shelf ID 0 - operate without a system controller.
- Otherwise, Power Shift shelf IDs must be unique.

Shelf ID	SW 1	SW 2
0	0 - down	0 - down
1	1 - up	0 - down
2	0 - down	1 - up
3	1 - up	1 - up

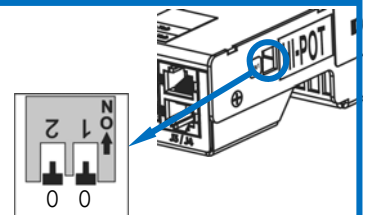

### Step 8 - Install Modules

1. Verify Module Type - use only 150045202 (PS1200DCxx) modules.
2. Slide converter into its slot approximately 3/4 of the way.
3. Open the faceplate by sliding the faceplate latch to the left until the faceplate releases and swings outward.
4. Slide the unit into the slot until it engages with the back of the shelf. Swing the faceplate closed to fully seat the converter. Verify the faceplate is latched.

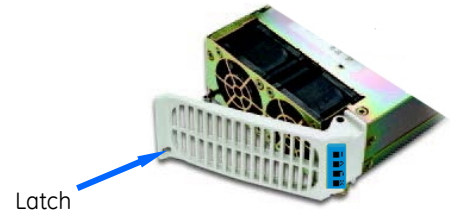

### Step 9 - Initial Start Up

1. Verify that all connections are complete and secure.
2. Turn on the DC input breakers.
3. Wait until LEDs stop blinking - up to 5 minutes.
4. If any module LEDs are not green, see *Information Module Status LEDs*

### Information: Module Status LEDs

Each Module has an LED for each circuit (1, 2, & 3), and one LED for the module itself.

• Intermittent or latent failures will be indicated by the X indicator.

• Some fault indications remain active after correction.

Reset the module by toggling the DC input circuit breaker for the unit.



Module Status LEDs				
Module OK LED X		Circuit LEDs <sup>2</sup> 1 - 3	Condition	Action
Priority <sup>1</sup>	LED			
	G	G	Circuit - ON - normal	
	G	OFF	Circuit - No Input Voltage	Apply DC Input
4	Y BLINK	Y BLINK	Circuit External Fault	See Circuit External Fault below. Toggle DC Input breaker after action applied.
2	R BLINK	R BLINK	Circuit Shutdown	Clear external fault. Toggle DC Input breaker. If fault remains replace module.
1	R	R	Circuit - Internal Fault	Replace module.
	-	Y	Circuit Standby (remote) <sup>3</sup>	Turn circuit ON via controller.
3	Y	G BLINK	Circuit Thermal Shutdown	Correct high ambient temperature and air flow blockage. Toggle DC Input breaker. If fault remains or reoccurs replace module.
3	Y	Per Circuit Condition	Defective Fan (not immediately service effecting)	Replace module.
1	R	Per Circuit Condition	Module Fail - Any Service effecting Internal Fault	Replace module.
5	R BLINK	Per Circuit Condition	RS-485 Comm Fault <sup>3</sup>	Connect to powered controller.

1. OK LED indicates the highest LED priority. Priority 1 is highest.

2. Each Circuit LED indicates the Condition of its Circuit, independently of the other Circuits.

3. Will not occur if shelf ID is 0.

Circuit External Fault - Circuit functioning properly, but not able to deliver power normally due to external cause	
Possible Cause	Action
a. Input out of range	Validate circuit input voltage at shelf input terminals - -42VDC to -58.8VDC.
b. Short circuit on output cables	Clear output cable short.
c. Low output voltage Circuit output power or voltage limits exceeded.	Install larger wire gauge output wire or additional output power wires in parallel.



## Specifications and Application

- Specifications and ordering information are in the Power Express RRH Ordering Guide available at [www.gecriticalpower.com](http://www.gecriticalpower.com)
- Equipment and subassembly ports: 1. are suitable for connection to intra-building or unexposed wiring or cabling;  
2. can be connected to shielded intra-building cabling grounded at both ends.
- Grounding / Bonding Network – Connect to an Isolated Ground Plane (Isolated Bonding Network) or an Integrated Ground Plane (Mesh Bonding Network or Common Bonding Network).
- Installation Environment - Install in Network Telecommunication Facilities, OSP, or where NEC applies.
- Battery return may be either Isolated DC return (DC-I) or Common DC return (DC-C).

## Reference Documents

These documents are available at [www.gecriticalpower.com](http://www.gecriticalpower.com).

Document	Title
	Power Express RRH Ordering Guide



## Safety Statements

- Do not install this equipment over combustible surfaces.
- Rules and Regulations - Follow all national and local rules and regulations when making field connections.
- Compression Connectors
  - U. S. or Canada installations - use Listed/Certified compression connectors to terminate Listed/Certified field-wire conductors where required.
  - All installations - apply the appropriate connector to the correct size conductor as specified by the connector manufacturer, using only the connector manufacturer's recommended or approved tooling for that connector.
- Electrical Connection Securing: Torque to the values specified on labels or in the product documentation.
- Cable Dress - dress to avoid damage to the conductors and undue stress on the connectors.
- Fuses and Circuit Breakers - Size as required by the National Electric Code (NEC) and/or local codes. Refer to the equipment ratings to assure current does not exceed:
  - Continuous Load (List 1) - 60% of protector rating
  - Maximum Load (List 2 - typically end of discharge) - 80% of protector rating.
- Field-wired Conductors - Follow all National Electric Code (NEC) and local rules and regulations .
  - Insulation rating: 90°C minimum; 105°C (minimum) if internal to enclosed equipment cabinets.
  - Size AC field-wired conductors with 75°C ampacity (NEC) equal to or greater than their panel board circuit breaker rating.
  - Size DC field-wired conductors with 90°C ampacity (NEC) equal to or greater than circuit breaker/fuse rating.
- AC and DC input disconnect/protection - Provide accessible devices to remove input power in an emergency.
- Alarm Signals - Provide external current limiting protection. Rating 60V, 0.5A unless otherwise noted.
- Grounding - Connect the equipment chassis directly to ground. In enclosed equipment cabinets connect to the cabinet ac service ground bus. In huts, vaults, and central offices connect to the system bonding network.
- Circuit Breakers and Fuses - Use only those specified in the equipment ordering guide.
- GMT Style Fuses - Use only fuses provided with safety caps.

## Precautions

- Install, service, and operate equipment only by professional, skilled and qualified personnel who have the necessary knowledge and practical experience with electrical equipment and who understand the hazards that can arise when working on this type of equipment.
- Disconnect batteries from outputs and/or follow safety procedures while working on equipment. Batteries may be connected in parallel with the output of the rectifiers. Turning off the rectifiers will not necessarily remove power from the bus.
- Do not disconnect permanent bonding connections unless all power inputs are disconnected.
- Verify that equipment is properly safety earth grounded before connecting power. High leakage currents may be possible.
- Exercise care and follow all safety warnings and practices when servicing this equipment. Hazardous energy and voltages are present in the unit and on the interface cables that can shock or cause serious injury. When equipped with ringer modules, hazardous voltages will be present on the ringer output connectors.
- Use the following precautions in addition to proper job training and safety procedures:
  - Use only properly insulated tools.
  - Remove all metallic objects (key chains, glasses, rings, watches, or other jewelry).
  - Follow Lock Out Tag Out (LOTO) procedures: customer specified, site specific, or general as appropriate. Disconnect all power input before servicing the equipment. Check for multiple power inputs.
  - Wear safety glasses.
  - Follow Personal Protective Equipment requirements: customer specified, site specific, or general as appropriate.
  - Test circuits before touching.
  - Be aware of potential hazards before servicing equipment.
  - Identify exposed hazardous electrical potentials on connectors, wiring, etc.
  - Avoid contacting circuits when removing or replacing covers;.
  - Use a personal ESD strap when accessing or removing electronic components.
- Personnel with electronic medical devices need to be aware that proximity to DC power and distribution systems, including batteries and cables, typically found in telecommunications utility rooms, can affect medical electronic devices, such as pacemakers. Effects decrease with distance.



## Notes



## Notes



## Notes

