



# Transformer



\*1M000000\*

Catalog Number

9T10A1194

Type QL

75.0 KVA 60 HZ 3 PH 5.6 % IMP

40 C AMB. 150 C RISE 220 C SYSTEM IS-19C

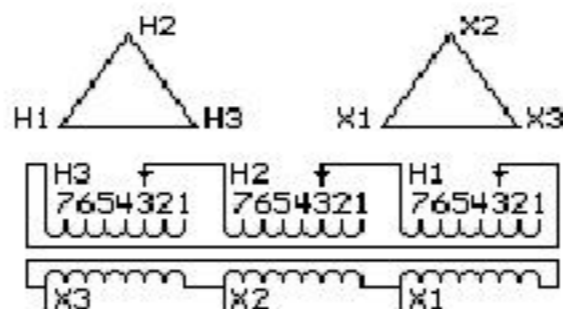

JUMPER CONNECTION	
TAP	VOLTS
1	505
2	491
3	480
4	469
5	455
6	445
7	431

NET WGT  
561 LB  
254.5 Kg

60568  
LY74A

NOG  
031716

INSPECTION  
&  
FINAL TEST  
N612!

PRIMARY (H) 480 VOLTS (LINE-LINE)  
SECONDARY (X) 240 VOLTS (LINE-LINE)

### COIL TAP ARRANGEMENT

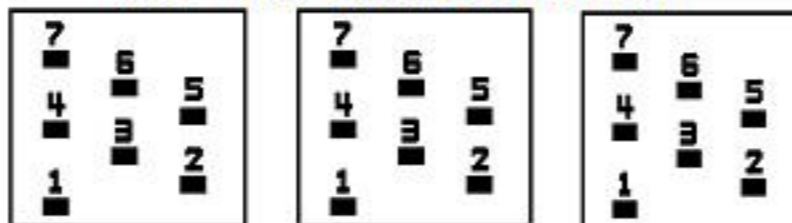

ENCLOSURE TYPE 2 (IP20). OR RAINPROOF TYPE 3R (IP22) WHEN PROVIDED SHIELD 9T18Y1074G06

Assembled in Mexico

BEFORE HANDLING, INSTALLING AND OPERATING, SEE INSTRUCTION 475A667AAP001  
ALUMINUM CONDUCTOR PRIMARY: 10 KV BIL SECONDARY: 10 KV BIL

Outline:  
303B111GEUY74A

X3 H3 X2 H2 X1 H1 -

IN ACCORDANCE WITH NEC SECTION 450-9, ALLOW AT LEAST SIX INCHES  
CLEARANCE FOR VENTILATION. CHECK ADDITIONAL NEC AND LOCAL CODE

Note: standard

X3 H3 X2 H2 X1 H1

X3 H3 X2 H2 X1 H1



\*2M000000\*



\*3M000000\*