



Transformer



1M0000000

Catalog Number **9T10A1452** Type **QL**

30.0 KVA 60 HZ 3 PH 5% IMP

40 C AMB. 150 C RISE 220 C SYSTEM IS-19C

PRIMARY (H) 208 VOLTS (LINE-LINE)
SECONDARY (X) 208 VOLTS (LINE-LINE)
120 VOLTS (LINE-NEUTRAL)

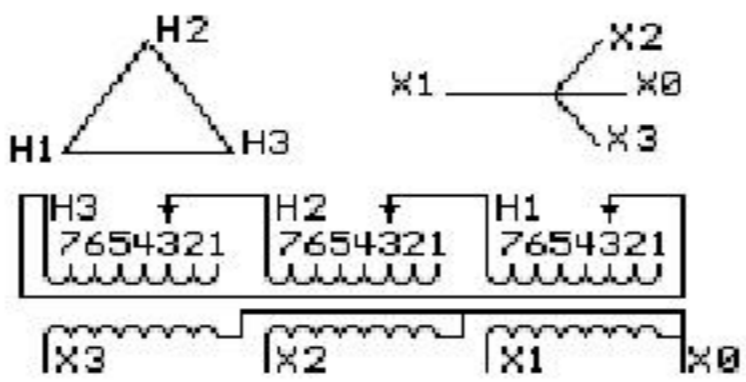

COIL TAP ARRANGEMENT

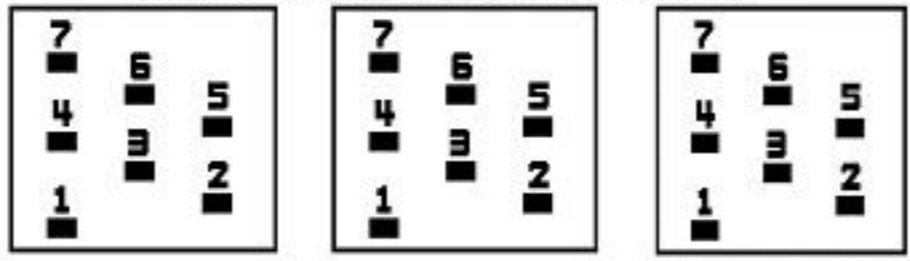

JUMPER CONNECTION TAP	VOLTS
1	218
2	214
3	208
4	202
5	198
6	192
7	188

NET WGT
330 LB
149.7 Kg

58778
UX72A
NOG
121715

INSPECTION & FINAL TEST N551!



ENCLOSURE TYPE 2 (IP20) OR RAINPROOF TYPE 3R (IP22) WHEN PROVIDED SHIELD 9T18Y1072G06

Assembled in Mexico

BEFORE HANDLING, INSTALLING AND OPERATING, SEE INSTRUCTION 475A667AAP001
ALUMINUM CONDUCTOR PRIMARY: 10 KV BIL SECONDARY: 10 KV BIL Outline: 303B111GEUXP72A

X3 H3 X2 H2 X1 H1 X0

IN ACCORDANCE WITH NEC SECTION 450-9, ALLOW AT LEAST SIX INCHES CLEARANCE FOR VENTILATION. CHECK ADDITIONAL NEC AND LOCAL CODE

Note: standard

X0
X1 H1
X2 H2
X3 H3
X1 H1
X2 H2
X3 H3
X0

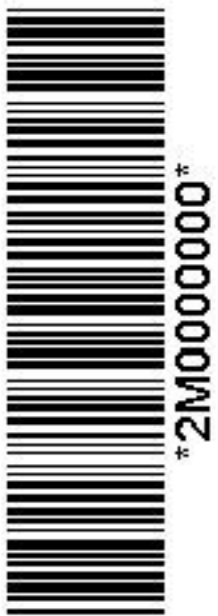

2M0000000



3M0000000