



Transformer

Catalog Number

9T83C9866

400.0 KVA 60 HZ 3 PH 3.8 % IMP

40 C AMB. 150 C RISE 220 C SYSTEM IS-19C Type: QL

Note: Design is based on 500.0KVA & 150C Rise 6.6% Imp.

PRIMARY (H)	480 VOLTS (LINE-LINE)
SECONDARY (X)	208 VOLTS (LINE-LINE)
	120 VOLTS (LINE-NEUTRAL)

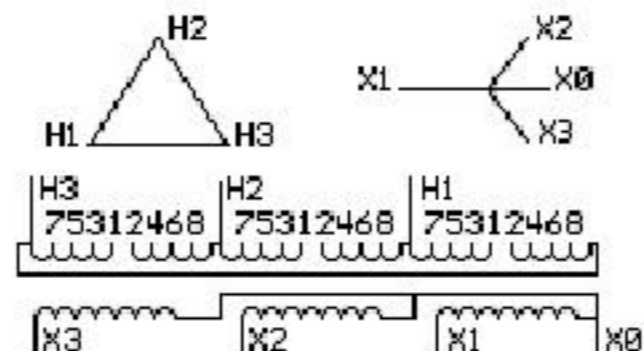

JUMPER CONNECTION

TAP	VOLTS
1-2	500
2-3	490
3-4	480
4-5	470
5-6	460
6-7	440
7-8	430

COIL TAP ARRANGEMENT

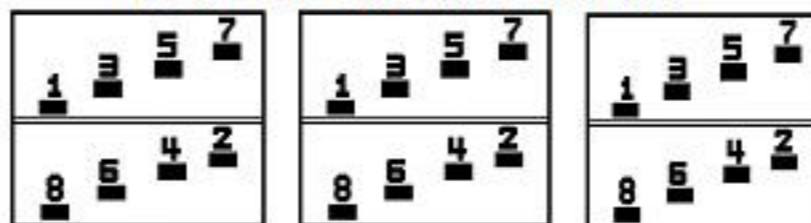

NET WGT 2900 LB 1315.4 Kg

090115	N536!	L39AA
	55825	NOG

ENCLOSURE TYPE 2 (IP30). RAINPROOF TYPE 3R ENCLOSURE (IP32) WHEN PROVIDED SHIELD 9T18Y4322G 68

BEFORE HANDLING, INSTALLING AND OPERATING, SEE INSTRUCTION 475A667AAP001
COPPER CONDUCTOR PRIMARY: 10 KV BIL SECONDARY: 10 KV BIL

IN ACCORDANCE WITH NEC SECTION 450-9, ALLOW AT LEAST SIX INCHES CLEARANCE FOR VENTILATION. CHECK ADDITIONAL NEC AND LOCAL CODES.



LISTED 769G

Outline: 3038912AAP179
Assembled in Mexico

INSPECTION & FINAL TEST
N536!

