

CAR3012TE series front-end

Input: 90Vac to 264Vac; Output: 12Vdc @ 3000W; 3.3 or 5Vdc @ 4A Standby

RoHS Compliant



Applications

- 12Vdc distributed power architectures
- Routers/ VoIP/Soft and other Telecom Switches
- Mid to high-end Servers, ATE Equipment

Features

- Efficiency: meets 80plus "Titanium" criteria
- Universal input with PFC
- Constant power characteristic
- 2 front panel LEDs: 1-input;2-[PG, fault, warning]
- ON/OFF control of the 12Vdc output
- Remote sense on the 12Vdc output
- No minimum load requirements
- Active load sharing (single wire)
- Hot Plug-ability
- Standby orderable either as 3.3Vdc or 5Vdc @ 4A
- Auto recoverable OC & OT protection
- Operating temperature: -10 - 60°C (de-rated above 50
- Digital status & control: dual/redundant PMBus™ seri bus
- UL and cUL approved to UL/CSA+62368-1, TUV (EN62368-1), CE[§] Mark
- Meets FCC part 15, EN55032 Class A standards
- Meets EN61000 immunity and transient standards
- Shock & vibration: Meets IPC 9592 Class II standards
- Front to back or reversed airflow w/air speed control
- Compliant to RoHS Directive 2011/65/EU and amended Directive (EU) 2015/863
- Compliant to REACH Directive (EC) No 1907/2006

Description

The CAR3012TE Front-End provides highly efficient isolated power from worldwide input mains in a compact 1U industry standard form factor. This power supply is ideal for applications where mid to light load efficiency is of key importance in order to reduce system power consumption during 'typical' operational conditions.

The high-density, front-to-back, or reversed, airflow is designed for minimal space utilization and is highly expandable for future growth. Dual/redundant, industry standard, PMBus™ compliant I2C communications busses offer a full range of control and monitoring capabilities with sequential control from two independent sources

* UL is a registered trademark of Underwriters Laboratories, Inc.

† CSA is a registered trademark of Canadian Standards Association.

‡ VDE is a trademark of Verband Deutscher Elektrotechniker e.V.

§ Intended for integration into end-user equipment. All the required procedures for CE marking of end-user equipment should be followed. (The CE mark is placed on selected products.)

** ISO is a registered trademark of the International Organization of Standards.

+ PMBus name and logo are registered trademarks of the System Management Interface Forum (SMIF)



CAR3012TE series front-end

Input: 90Vac to 264Vac; Output: 12Vdc @ 3000W; 3.3 or 5Vdc @ 4A Standby

Absolute Maximum Ratings

Stresses in excess of the absolute maximum ratings can cause permanent damage to the device. Functional operation is not implied in excess of the operations section. Exposure to absolute maximum ratings for extended periods can adversely affect the device reliability.

Parameter	Symbol	Min	Max	Unit
Input Voltage: Continuous	V _{IN}	0	264	V _{AC}
Operating Ambient Temperature	T _A	-10	70 ¹	°C
Storage Temperature	T _{stg}	-40	85	°C
I/O Isolation voltage to Frame (100% factory Hi-Pot tested)			2121	V _{DC}

Electrical Specifications

Unless otherwise indicated, specifications apply over all operating input voltage, load, and temperature conditions.

INPUT					
Parameter	Symbol	Min	Typ	Max	Unit
Operational Range	V _{IN}	85	115/230	264	V _{AC}
Frequency Range (ETSI 300-132-1 recommendation)	F _{IN}	47	50/60	63	Hz
Main Output Turn OFF	V _{IN}	70		80	V _{AC}
Main Output Turn ON		75		85	
Hysteresis between turn OFF and turn ON		5			
Maximum Input Current (V _O = V _{O, set} , I _O =I _{O, max}) V _{IN} = 100V _{AC} V _{IN} = 208V _{AC}	I _{IN}			16.3 15.9	A _{AC}
Cold Start Inrush Current (Excluding x-caps, 25°C, <10ms, per ETSI 300-132)	I _{IN}			40	A _{PEAK}
Efficiency ² (T _{amb} =25°C, V _O = 12V) V _{IN} 100% load 50% load 20% load 10% load	η		115V/230V/230V ₈₀₊ 92/93/91 92.5/94/96 87/93/94 75/88/90		%
Power Factor (V _{IN} =115/230V _{AC} , I _O = 50% I _{O, max} I _O = I _{O, max})	PF		0.98 0.99		
Holdup time (V _{out} ≥ 10.8V _{DC} , T _{amb} 25°C, I _O =I _{O, max}) V _{IN} = 230V _{AC} V _{IN} = 100V _{AC}	T	10	12 20		ms
Early warning prior to output falling below regulation ³		2			
Ride through	T		10		
Leakage Current (V _{IN} = 250V _{AC} , F _{IN} = 60Hz)	I _{IN}			3	mA _{RMS}
Isolation Input/Output		3000			V _{AC}
Input/Frame		2121			V _{DC}
Output/Frame		100			V _{DC}

12V _{dc} MAIN OUTPUT					
Parameter	Symbol	Min	Typ	Max	Unit
Output Power 180 – 264 / 90-132 Vac V _{AC} ≤ 90V _{AC}	W	0 0	- -	3000/1400 1200	W W
Factory Set default set point	V _O	11.9	12.00	12.1	V _{DC}
Overall regulation (load, temperature)		-2		+2	%

¹ Power derated above 50°C, see environmental section

² 80+ Titanium standard test method: 25°C, Standby @ NL, fan powered externally. Standard test method: 25°C, Standby @ FL, fan powered internally

³ Measured by the PG# signal going LO prior to the output decaying below 10.8Vdc

CAR3012TE series front-end

Input: 90Vac to 264Vac; Output: 12Vdc @ 3000W; 3.3 or 5Vdc @ 4A Standby

12V _{dc} MAIN OUTPUT (continued)					
Parameter ⁴	Symbol	Min	Typ	Max	Unit
Ripple and noise				120	mV _{P-P}
Turn-ON overshoot				+5	%
Turn-ON delay	T			3	sec
ON/OFF delay time			100		ms
Turn-ON rise time (10 – 90% of V _{out})				50	ms
External capacitance capability				10,000	μF
Transient response 50% step [10%-60%, 50% - 100%] (di/dt – 1A/μs, recovery 300μs)		-5		+5	%V _o
Programmable range (hardware & software)	V _o	10.8		13.2	V _{DC}
Overvoltage protection, latched (recover cycling 12V output OFF/ON)	V _o ≤ 12.6V V _o > 12.6V	13.3 13.8	13.9 14.8	14.5 15.8	V _{DC}
Output current 180 ≥ V _{IN} ≥ 264 90 ≥ V _{IN} ≥ 132		0		250 117	A _{DC}
Current limit, Hiccup (programmable level)		105		130	% of FL
Active current share		-5		+5	% of FL

STANDBY OUTPUT					
Parameter	Symbol	Min	Typ	Max	Unit
Set point	V _o		3.3 / 5.0		V _{DC}
Overall regulation (load, temperature, aging)	V _o	-5		+5	%
Ripple and noise				50	mV _{P-P}
Output current	I _o	0		4	A _{DC}
Overload protection -		110		150	% of FL
Isolation Output/Frame		100			V _{DC}

General Specifications

Parameter	Min	Typ	Max	Units	Notes
Reliability, 25°C 50°C		320,000 100,000		Hrs	Full load, ; MTBF per SR232 Reliability protection for electronic equipment, method I, case III,
Service Life		10		Yrs	Full load, excluding fans
Weight					

Feature Specifications

Unless otherwise indicated, specifications apply over all operating input voltage, resistive load, and temperature conditions. See Control and Status for additional information. V_{DD} = 3.3V_{DC}

Parameter	Symbol	Min	Typ	Max	Unit
ON/OFF (An internal pull-up resistor is provided)					
Logic High (Module ON)	I _{IH}		—	20	μA
	V _{IH}	0.7V _{DD}	—	12	V _{DC}
Logic Low (Module OFF)	I _{IL}	—	—	4	mA
	V _{IL}	0	—	0.8	V _{DC}

⁴ Ripple and transient response measured across 5 x 22μf and 1 x 0.1μf ceramic capacitors in parallel. 20MHz bandwidth.

CAR3012TE series front-end

Input: 90Vac to 264Vac; Output: 12Vdc @ 3000W; 3.3 or 5Vdc @ 4A Standby

Feature Specifications (continued)

Parameter	Symbol	Min	Typ	Max	Unit
Output Voltage programming (Vprog) Equation: $V_{out} = 10.8 + (V_{prog} * 0.96)$					
Vprog range	V_{prog}	0	—	2.5	V _{DC}
Programmed output voltage range	V_o	10.8	—	13.2	V _{DC}
Voltage adjustment resolution	V_o	—	10	—	mV _{DC}
Output configured to 13.2Vdc	V_{prog}	2.5	—	3.0	V _{DC}
Output configured to the 12Vdc set-point	V_{prog}	3.0	—	—	V _{DC}
Interlock [short pin controlling presence of the 12V _{DC} output] (pulled up internally to V _{DD} by a 10kΩ resistor)					
12V output OFF	V_I	2.42	—	3.46	V _{DC}
12V output ON	V_I	0	—	0.4	V _{DC}
PG# (pulled up internally to V _{DD} by a 10kΩ resistor) Logic					
High (Output voltage is present; $V_{OUT} \geq 10.7V_{dc}$)	I_{OH}	—	—	20	μA
	V_{OH}	2.42	—	3.46	V _{DC}
Logic Low (Output voltage is not present; $V_{OUT} \leq 10.2V_{dc}$)	I_{OL}	—	—	4	mA
	V_{OL}	0	—	0.4	V _{DC}
OTW# (pulled up internally to V _{DD} by a 10kΩ resistor)					
Logic High (temperature within normal range)	I_{OH}	—	—	20	μA
	V_{OH}	2.42	—	3.46	V _{DC}
Logic Low (temperature is too high)	I_{OL}	—	—	4	mA
	V_{OL}	0	—	0.4	V _{DC}
Delayed shutdown after Logic Low transition	Tdelay	10	—	—	sec
Fault# (pulled up internally to V _{DD} by a 10kΩ resistor)					
Logic High (No fault is present)	I_{OH}	—	—	20	μA
	V_{OH}	2.42	—	3.46	V _{DC}
Logic Low (Fault is present)	I_{OL}	—	—	4	mA
	V_{OL}	0	—	0.4	V _{DC}
PS Present [internally connected to Logic_GRD] (Needs to be pulled HI via an external resistor)					
Logic High (Power supply is not plugged in)					
Logic Low (Power supply is present)	V_{IL}	0	—	0.1	V _{DC}
8V_INT (no components should be connected to this pin)					
SCL, SDA (internally pulled up to 3.3V by a 51kΩ resistor)					
Logic High	V_{IH}	0.7V _{DD}	—	V _{DD}	V _{DC}
Logic Low	V_{OL}	0	—	0.4	V _{DC}
Bias supply voltage	V_{DD}	—	3.3	—	V _{DC}
SMBAAlert# (no internal pull up provided, ref: Logic_GRD)					
Voltage tolerance on signal pin	$V_{IN I}$	—	—	5	V _{DC}
Sink current capability	V_{OL}	—	—	5	mA _{DC}
Logic Low		—	—	0.4	V _{DC}

CAR3012TE series front-end

Input: 90Vac to 264Vac; Output: 12Vdc @ 3000W; 3.3 or 5Vdc @ 4A Standby

Digital Interface Specifications

Parameter	Conditions	Symbol	Min	Typ	Max	Unit
PMBus Signal Interface Characteristics⁵						
Input Logic High Voltage (CLK, DATA)		V _{IH}	0.7V _{DD}		3.6	V
Input Logic Low Voltage (CLK, DATA)		V _{IL}	0		0.8	V
Input high sourced current (CLK, DATA)		I _{IH}	0		10	μA
Output Low sink Voltage (CLK, DATA, ALERT#)	I _o =5mA	V _{OL}			0.4	V
Output Low sink current (CLK, DATA, ALERT#)		I _{OL}			5	mA
Output High open drain leakage current (CLK, DATA, ALERT#)	V _o =3.6V	I _{OH}	0		10	μA
PMBus Operating frequency range	Slave Mode	F _{PMB}	10		400	kHz
Measurement System Characteristics						
Clock stretching		t _{STRETCH}			25	ms
I _{OUT} measurement range	Linear	I _{RNG}	0		242	A
I _{OUT} measurement accuracy 25°C		I _{OUT}	-2.5		+2.5	% of FL
V _{OUT} measurement range	Linear	V _{OUT(rng)}	0		14	V
V _{OUT} measurement accuracy		V _{OUT(acc)}	-1		+1	%
Temp measurement range	Linear	Temp _(rng)	0		125	°C
Temp measurement accuracy ⁶		Temp _(acc)	-3		+3	°C
I _{IN} measurement range	Linear	I _{IN(rng)}	0		18	A _{AC}
I _{IN} measurement accuracy - standard measurement @ 25°C		I _{IN(acc)}	-4		+4	% of FL
V _{IN} measurement range	Linear	V _{IN(rng)}	0		320	V _{AC}
V _{IN} measurement accuracy		V _{IN(acc)}	-2		+2	%
P _{IN} measurement range	Linear	P _{N(rng)}	0		3000	W
P _{IN} measurement accuracy – standard measurement @ 25°C	> 350W < 350W	P _{in(acc)}	-5 -50		+5 50	% W
Fan Speed measurement range	Linear		0		30k	RPM
Fan Speed measurement accuracy			-10		10	%
Fan speed control range	Linear		0		100	%

⁵ Clock, Data, and Alert need to be pulled up to V_{DD} externally.

⁶ Temperature accuracy reduces non-linearly with decreasing temperature

CAR3012TE series front-end

Input: 90Vac to 264Vac; Output: 12Vdc @ 3000W; 3.3 or 5Vdc @ 4A Standby

Environmental Specifications

Parameter	Min	Typ	Max	Units	Notes
Ambient Temperature Normal airflow Reverse airflow Vin > 180Vac Reverse airflow Vin > 90Vac	-10 ⁷		50 35 47	°C	
Storage Temperature	-40		85	°C	
Operating Altitude			2250/7382	m/ft	
Non-operating Altitude			8200/26900	m / ft	
Power Derating with Temperature Normal airflow Reverse airflow Vin > 180Vac Reverse airflow Vin > 90Vac			4 2.5 4	%/°C	50°C to 60°C 35°C to 50°C 47°C to 50°C
Power Derating with Altitude			2.0	°C/301 m °C/1000 ft	Above 1524 m/5000 ft
Acoustic noise		55 45		dbA	Full load Half load
Over Temperature Protection		78/70		°C	Shutdown / restart
Humidity Operating Storage	5 5		95 95	%	Relative humidity, non-condensing
Shock and Vibration	Meet IPC 9592 Class II, Section 5 requirements				

EMC Compliance

Parameter	Function	Standard	Level	Criteria	Test
AC input	Conducted emissions	EN55032, FCC part 15 EN61000-3-2	A		0.15 – 30MHz 0 – 2 KHz
	Radiated emissions**	EN55032	A		30 – 10000MHz
AC input immunity	Voltage dips	EN61000-4-11		A	-30%, 10ms
				B	-60%, 100ms
				B	-100%, 5sec
	Voltage surge	EN61000-4-5		A	4kV, 1.2/50µs, common mode 2kV, 1.2/50µs, differential mode
	Fast transients	EN61000-4-4		A	5/50ns, 2kV (common mode)
Enclosure immunity	Conducted RF fields	EN61000-4-6	A		130dBµV, 0.15-80MHz, 80% AM
	Radiated RF fields	EN61000-4-3	A		10V/m, 80-1000MHz, 80% AM
		ENV 50140	A		
	ESD	EN61000-4-2	B		4kV contact, 8kV air

** Radiated emissions compliance is contingent upon the final system configuration.

Criteria	Performance
A	No performance degradation
B	Temporary loss of function or degradation not requiring manual intervention
C	Temporary loss of function or degradation that may require manual intervention
D	Loss of function with possible permanent damage

⁷ Designed to start at an ambient down to -40°C; meet spec after ≅ 30 min warm up period, may not meet operational limits below -10°C.

CAR3012TE series front-end

Input: 90Vac to 264Vac; Output: 12Vdc @ 3000W; 3.3 or 5Vdc @ 4A Standby

Timing Diagrams

Response to input fluctuations

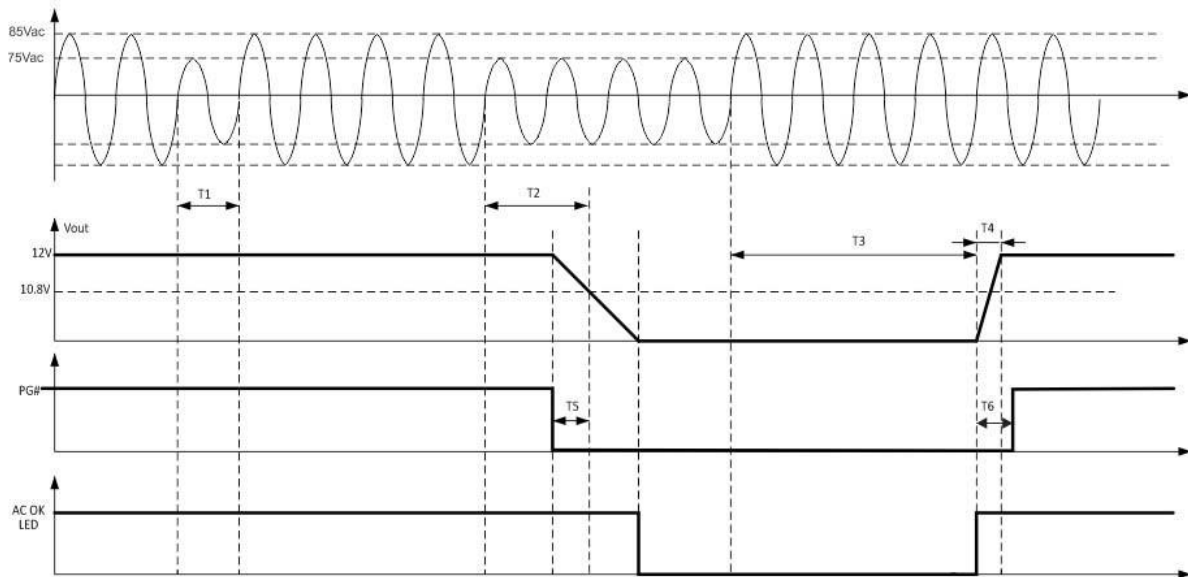

T1 - ride through time - typically 0.5 cycles [10 ms] Vout remains within regulation. Actual performance depends on output load

T2 - hold up time - 12ms @ 230Vac, 20ms @ 100Vac; Vout stays above 10.8Vdc under all loading conditions

T3 - delay time - > 2ms from the time AC returns within regulation to when the out starts rising

T4 - rise time - 50ms max. to within regulation

T5 - power good (PG#) - 2ms minimum warning indicated by the PG# signal going LO before Vout falls below 10.8Vdc

AC OK LED: Blinking when AC input falls below approx, 75Vac as long as bias power is available

T6 > T4 - The PG# signal de-asserts after the output is within regulation

CAR3012TE series front-end

Input: 90Vac to 264Vac; Output: 12 Vdc @ 3000W; 3.3Vdc or 5 Vdc @ 4A

Control and Status

Control hierarchy: Some features, such as output voltage, can be controlled both through hardware and firmware. For example, the output voltage is controlled both by a signal pin (Vprog) and firmware (Vout_command; 0x21).

Using output voltage as an example, the Vprog signal pin voltage level sets the output voltage if its value is < 3V_{DC}. (see the Vprog section). When the programming signal Vprog is either a no connect or > 3V_{DC}, the output voltage is set at the default value of 54V_{DC}.

The signal pin controls the feature it is configuring until a firmware command is executed. However, once the firmware command has been executed, the signal pin is ignored. In the above example, the rectifier will no longer 'listen' to the Vprog pin if the Vout_command has been executed.

In summary, signals such as Vprog are utilized for setting the initial default value and for varying the value until firmware based control takes over. Once firmware control is executed, hardware based control is relinquished so the processor can clearly decide who has control.

Analog controls: Details of analog controls are provided in this data sheet under Feature Specifications.

Common ground: All signals and outputs are referenced to Output return (power) including the Logic_GRD (signal).

Control Signals

Protocol: This signal pin defines the communications mode setting of the power supply. Two different states can be configured. State #1 is the I²C application in which case the protocol pin should be left a no-connect. State #2 is the RS485 mode application in which case a resistor value between 1kΩ and 5kΩ should be present between this pin and Vout (-).

Device address in I²C mode: Address bits A3, A2, A1, A0 set the specific address of the μP in the power supply. With these four bits, up to sixteen (16) power supplies can be independently addressed on a single I²C bus. These four bits are configured by two signal pins, Unit_ID and Rack_ID. The least significant bit x (LSB) of the address byte is set to either **write [0]** or **read [1]**. A **write** command instructs the power supply. A **read** command accesses information from the power supply.

Device	Address	Address Bit Assignments (Most to Least Significant)							
		7	6	5	4	3	2	1	0
MCU	Cx or Dx	1	1	0	A3	A2	A1	A0	R/W
Broadcast	00	0	0	0	0	0	0	0	0
		MSB				LSB			

Unit_ID: Up to 10 different units are selectable.

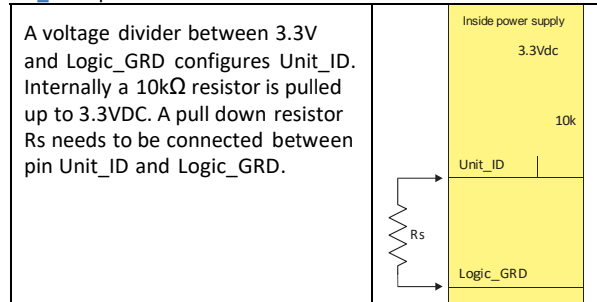

Unit_ID	Voltage level	Rs (± 0.1%)
Invalid	3.30	
1	3.00	100k
2	2.67	45.3k
3	2.34	24.9k
4	2.01	15.4k
5	1.68	10.5k
6	1.35	7.15k
7	1.02	4.99k
8	0.69	2.49k
9	0.36	1.27k
10	0	0

Rack_ID: Up to 8 different combinations are selectable.

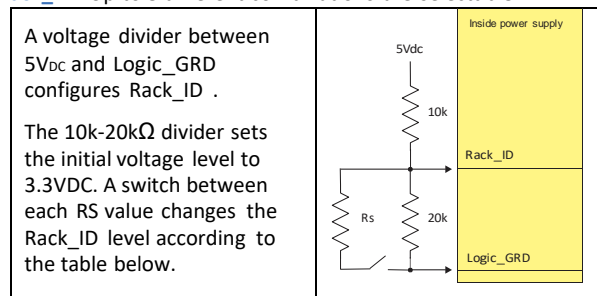

Rack_ID	Voltage level	Rs (± 0.1%)
1	3.3	open
2	2.8	35.2k
3	2.3	15k
4	1.8	8k
5	1.4	4.99k
6	1	2.87k
7	0.5	1.27k
8	0	0

CAR3012TE series front-end

Input: 90Vac to 264Vac; Output: 12 Vdc @ 3000W; 3.3Vdc or 5 Vdc @ 4A

Configuration of the A3 – A0 bits: The power supply will determine the configured address based on the Unit_ID and Rack_ID voltage levels as follows (the order is A3 – A0):

		Unit_ID				
		1	2	3	4	5
Rack_ID	1	0000	0001	0010	0011	0000
	2	0100	0101	0110	0111	0000
	3	1000	1001	1010	1011	0000
	4	1100	1101	1110	1111	0000
	5	0000	0000	0000	0000	0000
	6	0000	0001	0010	0011	0100
	7	0101	0110	0111	1000	1001
	8	1010	1011	1100	1101	1110

Unit x Rack: 4 x 4 and 5 x 3

		Unit_ID				
		6	7	8	9	10
Rack_ID	1	0000	0001	0000	0000	0000
	2	0010	0011	0000	0000	0000
	3	0100	0101	0000	0000	0000
	4	0110	0111	0000	0001	0010
	5	1000	1001	0011	0100	0101
	6	1010	1011	0110	0111	1000
	7	1100	1101	1001	1010	1011
	8	1110	1111	1100	1101	1110

Unit x Rack: 2 x 8 and 3 x 5

Device address in RS485 mode: The power supply is configured for a static, single, address internally. This mode of operation is used only for factory testing.

Global Broadcast: This is a powerful command because it instruct all power supplies to respond simultaneously. A **read** instruction should never be accessed globally. The power supply should issue an 'invalid command' state if a 'read' is attempted globally.

For example, changing the 'system' output voltage requires the global broadcast so that all paralleled power supplies change their output simultaneously. This command can also turn OFF the 'main' output or turn ON the 'main' output of all power supplies simultaneously. Unfortunately, this command does have a side effect. Only a single power supply needs to pull down the ninth *acknowledge* bit. To be certain that each power supply responded to the global instruction, a *READ* instruction should be executed to each power supply to verify that the command properly executed. The GLOBAL BROADCAST command should only be executed for write instructions to slave devices.

Voltage programming (V_{prog}): Hardware voltage programming controls the output voltage until a software issued command to change the output voltage is executed. Software voltage programming permanently overrides the hardware V_{prog} setting and the power supply no longer listens to the hardware setting until power to the controller is interrupted, for example if input power or bias power is recycled.

When bias power is recycled to the controller the controller restarts into its default configuration, programmed to set the output as instructed by the V_{prog} pin. Again, subsequent software commanded settings permanently override the margin setting. As an example, adding a resistor between V_{prog} and Logic_GRD is an effective way of changing the factory set point of the power supply to whatever voltage level is desired by the user during initial start-up.

The V_{prog} pin level should be set by a divider from 3.3Vdc to Logic_GRD external to the power supply as shown in the graph. Programming can be accomplished either by a resistor divider or by a voltage source injecting a precision voltage level into the V_{prog} pin. Above 3Vdc the power supply sets the output to its default state.

An analog voltage on this signal can vary the output voltage $\pm 10\%$ from 10.8Vdc to 13.2Vdc.

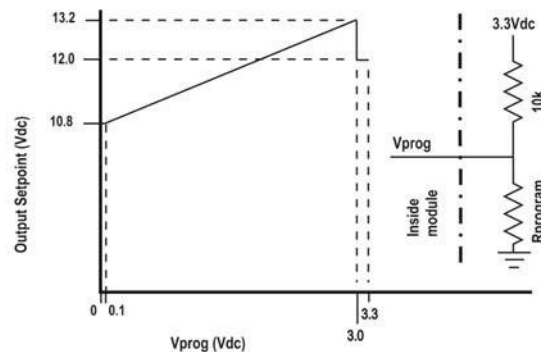

Load share (I_{share}): This is a single wire analog signal that is generated and acted upon automatically by power supplies connected in parallel. I_{share} pins should be connected to each other for power supplies, if active current share among the power supplies is desired. No resistors or capacitors should get connected to this pin.

Remote ON/OFF: Controls the presence of the main 12Vdc output voltage. This is an open collector signal that needs to be pulled HI externally through a resistor. A logic HI turns ON the main output.

A turn OFF command either through this signal (Remote ON/OFF) or firmware commanded would turn OFF the 12V output.

Interlock: This is a short signal pin that controls the presence of the 12Vdc main output. This pin should be

CAR3012TE series front-end

Input: 90Vac to 264Vac; Output: 12 Vdc @ 3000W; 3.3Vdc or 5 Vdc @ 4A

connected to 'Logic_GRD' on the system side of the output connector. This short pin ensures that no arcing or contact damage occurs to the connector during the hot insertion/extraction process.

8V_INT: Provides the ability to back_bias a front-end that lost input power thus maintaining the ability to communicate with a remote controller. This pin should be interconnected among units in a system.

Status signals

PS Present: This signal notifies the system controller that a power supply is physically present in the slot. This signal pin is pulled down to Output_return by the power supply.

PG#: A TTL compatible status signal representing whether the output voltage is present. This signal needs to be pulled HI externally through a resistor.

Fault#: This signal goes LO for any failure that requires power supply replacement. These faults may be due to:

- Fan failure
- Over-temperature shutdown
- Over-voltage shutdown
- Internal Power supply Fault

Over Temperature Warning (OTW#): A TTL compatible status signal representing whether an over temperature exists. This signal needs is pulled HI internally through a resistor.

If an over temperature should occur, this signal would pull LO for approximately 10 seconds prior to shutting down the power supply. In its default configuration, the unit would restart if internal temperatures recover within normal operational levels. At that time the signal reverts back to its open collector (HI) state.

Serial Bus Communications

The I²C interface facilitates the monitoring and control of various operating parameters within the unit and transmits these on demand over an industry standard I²C Serial bus.

All signals are referenced to 'Logic_GRD'.

Pull-up resistors: The clock, data lines include a 51kΩ internal weak pull up. SMBusAlert# does not have an internal pull-up resistor inside the power supply. The user is responsible for ensuring that the transmission impedance of the communications lines complies with I²C and SMBus standards.

Serial Clock (SCL): The clock pulses on this line are generated by the host that initiates communications across the I²C Serial bus. This signal needs to be pulled HI externally

through a resistor as necessary to ensure that rise and fall time timing and the maximum sink current is in compliance to the I²C /SMBus specifications.

Serial Data (SDA): This line is a bi-directional data line. This signal needs to be pulled HI externally through a resistor as necessary to ensure that rise and fall time timing and the maximum sink current is in compliance to the I²C /SMBus specifications.

SMBUSAlert#: This hardware signal pin is normally HI. When asserted (logic LO) it signifies to the system controller that the state of the power supply has changed or that communication errors occurred.

The SMBusAlert# line exciting the power supply combines the Alert# functions of power supply control and dual_bus_control.

Digital Feature Descriptions

PMBus™ compliance: The power supply is fully compliant to the Power Management Bus (PMBus™) rev1.2 requirements. This Specification can be obtained from www.pmbus.org.

'Manufacturer Specific' commands are used to support additional instructions that are not in the PMBus™ specification.

All communication over the PMBus interface must support the Packet Error Checking (PEC) scheme. The PMBus master must generate the correct PEC byte for all transactions, and check the PEC byte returned by the power supply.

Non-volatile memory is used to store configuration settings. Not all settings programmed into the device are automatically saved into this non-volatile memory. Only those specifically identified as capable of being stored can be saved. (see the Table of Commands for which command parameters can be saved to non-volatile storage).

Non-supported commands: Non supported commands are flagged by setting the appropriate STATUS bit and issuing an Alert# to the 'host' controller.

If a non-supported read is requested the power supply will return 0x00h for data.

Data out-of-range: The power supply validates data settings and sets the data out-of-range bit and Alert# if the data is not within acceptable range.

Master/Slave: The 'host controller' is always the MASTER. Power supplies are always SLAVES. SLAVES cannot initiate communications or toggle the Clock. SLAVES also must respond expeditiously at the command of the MASTER as required by the clock pulses generated by the MASTER.

CAR3012TE series front-end

Input: 90Vac to 264Vac; Output: 12 Vdc @ 3000W; 3.3Vdc or 5 Vdc @ 4A

Clock stretching: The 'slave' μ Controller inside the power supply may initiate clock stretching if it is busy and it desires to delay the initiation of any further communications. During the clock stretch the 'slave' may keep the clock LO until it is ready to receive further instructions from the host controller. The maximum clock stretch interval is 25ms.

The host controller needs to recognize this clock stretching, and refrain from issuing the next clock signal, until the clock line is released, or it needs to delay the next clock pulse beyond the clock stretch interval of the power supply.

Note that clock stretching can only be performed after completion of transmission of the 9th ACK bit, the exception being the START command.

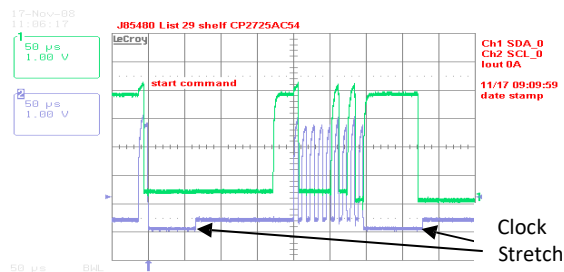

Example waveforms showing clock stretching.

I²C Bus Lock-Up detection: The device will abort any transaction and drop off the bus if it detects the bus being held low for more than 35ms.

Communications speed: Both 100kHz and 400kHz clock rates are supported. The power supplies default to the 100kHz clock rate. The minimum clock speed specified by SMBus is 10 kHz.

Packet Error Checking (PEC): The power supply will not respond to commands without the trailing PEC because the integrity of communications is compromised without packet error correction deployment.

PEC is a CRC-8 error-checking byte, based on the polynomial $C(x) = x^8 + x^2 + x + 1$, in compliance with PMBus™ requirements. The calculation is performed on all message bytes, including the originating write address and command bytes preceding read instructions. The PEC is appended to the message by the device that supplied the last byte.

Alert#: The power supply can issue Alert# driven from either its internal micro controller (μ C) or from the I²C bus master selector stage. That is, the Alert# signal of the internal μ C funnels through the master selector stage that buffers the Alert# signal and splits the signal to the two Alert# signal pins exiting the power supply. In addition, the master selector stage signals its own Alert# request to either of the two Alert# signals when required.

The μ C driven Alert# signal informs the 'master/host' controller that either a STATE or ALARM change has occurred. Normally this signal is HI. The signal will change to its LO level if the power supply has changed states and the signal will be latched LO until the power supply receives a 'clear_faults' instruction.

The signal will be triggered for any state change, including the following conditions;

- VIN under or over voltage
- Vout under or over voltage
- IOU over current
- Over Temperature warning or fault
- Fan Failure
- Communication error
- PEC error
- Invalid command
- Internal faults
- Both Alert#_0 and -1 are asserted during power up to notify the master that a new power supply has been added to the bus.

The power supply will clear the Alert# signal (release the signal to its HI state) upon the following events:

- Receiving a CLEAR_FAULTS command
- Bias power to the processor is recycled

The power supply will re-assert the Alert line if the internal state of the power supply has changed, even if that information cannot be reported by the status registers until a clear_faults is issued by the host. If the Alert asserts, the host should respond by issuing a clear_faults to retire the alert line (this action also provides the ability to change the status registers). This action triggers another Alert assertion because the status registers changed states to report the latest state of the power supply. The host is now able to read the latest reported status register information and issue a clear_faults to retire the Alert signal.

Re-initialization: The I²C code is programmed to re-initialize if no activity is detected on the bus for 5 seconds. Re-initialization is designed to guarantee that the I²C μ Controller does not hang up the bus. Although this rate is longer than the timing requirements specified in the SMBus specification, it had to be extended in order to ensure that a re-initialization would not occur under normal transmission rates. During the few μ seconds required to accomplish re-initialization the I²C μ Controller may not recognize a command sent to it. (i.e. a start condition).

Read back delay: The power supply issues the Alert# notification as soon as the first state change occurred. During an event a number of different states can be transitioned to before the final event occurs. If a read back is implemented rapidly by the host a successive Alert# could be triggered by the transitioning state of the power supply. In order to avoid successive Alert#s and read back and also to avoid reading a transitioning state, it is prudent to wait more than 2 seconds after the receipt of an Alert# before executing a read back. This delay will ensure that only the final state of the power supply is captured.

CAR3012TE series front-end

Input: 90Vac to 264Vac; Output: 12 Vdc @ 3000W; 3.3Vdc or 5 Vdc @ 4A

Successive read backs: Successive read backs to the power supply should not be attempted at intervals faster than every one second. This time interval is sufficient for the internal processors to update their data base so that successive reads provide fresh data.

Dual Master Control:

Two independent I²C lines provide true communications bus redundancy and allow two independent controllers to sequentially control the power supply. For example, a short or an open connection in one of the I²C lines does not affect communications capability on the other I²C line. Failure of a 'master' controller does not affect the power supplies and the second 'master' can take over control at any time.

Conceptually a Digital Signal Processor (DSP) referenced to Vout(-) of the power supply provides secondary control. A Bidirectional Isolator provides the required isolation between power GRD, Vout(-) and signal GRD (Logic_GRD). A secondary micro controller provides instructions to and receives operational data from the DSP. The secondary micro controller also controls the communications over two independent I²C lines to two independent system controllers.



The secondary micro controller is designed to default to I²C_0 when powered up. If only a single system controller is utilized, it should be connected to I²C_0. In this case the I²C_1 line is totally transparent as if it does not exist.

If two independent system controllers are utilized, then one of them should be connected to I²C_0 and the other to I²C_1.

At power up the master connected to I²C_0 has control of the bus. See the section on Dual Master Control for further description of this feature.

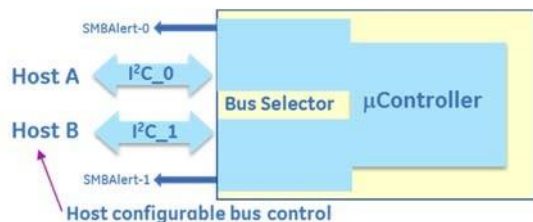

Conceptual representation of the dual I²C bus system.

PMBus™ Commands

Standard instruction: Up to two bytes of data may follow an instruction depending on the required data content. Analog data is always transmitted as LSB followed by MSB. PEC is optional and includes the address and data fields.

1	8	1	8	1
S	Slave address	Wr	A	Command Code

8	1	8	1	8	1	1
Low data byte	A	High data byte	A	PEC	A	P

Master to Slave Slave to Master

SMBUS annotations; S – Start, Wr – Write, Sr – re-Start, Rd – Read, A – Acknowledge, NA – not-acknowledged, P – Stop

Standard READ: Up to two bytes of data may follow a READ request depending on the required data content. Analog data is always transmitted as LSB followed by MSB. PEC is mandatory and includes the address and data fields.

1	7	1	1	8	1
S	Slave address	Wr	A	Command Code	A

1	7	1	1	8	1
Sr	Slave Address	Rd	A	LSB	A

8	1	8	1	1
MSB	A	PEC	No-ack	P

Block communications: When writing or reading more than two bytes of data at a time BLOCK instructions for WRITE and READ commands are used instead of the Standard Instructions above to write or read any number of bytes greater than two.

Block write format:

1	7	1	1	8	1
S	Slave address	Wr	A	Command Code	A

8	1	8	1	8	1
Byte count = N	A	Data 1	A	Data 2	A

8	1	8	1	8	1	1
.....	A	Data N ≤ 48	A	PEC	A	P

Block read format:

1	7	1	1	8	1
S	Slave address	Wr	A	Command Code	A

1	7	1	1
Sr	Slave Address	Rd	A

8	1	8	1	8	1
Byte count = N	A	Data 1	A	Data 2	A

8	1	8	1	8	1	1
.....	A	Data N ≤ 48	A	PEC	NoAck	P

CAR3012TE series front-end

Input: 90Vac to 264Vac; Output: 12 Vdc @ 3000W; 3.3Vdc or 5 Vdc @ 4A

Linear Data Format: The definition is identical to Part II of the PMBus Specification. All standard PMBus values, with the exception of output voltage related functions, are represented by the linear format described below. Output voltage functions are represented by a 16 bit mantissa. The value of the exponent for output voltage functions is listed in the Vout_mode command.

The Linear Data Format is a two byte value with an 11-bit, two's complement mantissa and a 5-bit, two's complement exponent or scaling factor, its format is shown below.

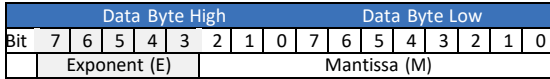

The relationship between the Mantissa, Exponent, and Actual Value (V) is given by the following equation:

$$V = M * 2^E$$

Where:

V is the value

M is the 11-bit, two's complement mantissa

E is the 5-bit, two's complement exponent

Standard features

The commands below are 'read only'. They cannot be modified.

Command	Comments
ON_OFF_CONFIG (0x02)	Both the CNTL pin, enabling or disabling the output, and the OPERATION command are not supported. Other options are not supported.
Vout_OV_fault_response (0x41)	Only latched (0x80) is supported
CAPABILITY (0x19)	400KHz, ALERT
PMBus revision (0x98)	1.2

Status and Alarm registers: The registers are updated with the latest operational state of the power supply. For example, whether the output is ON or OFF is continuously updated with the latest state of the power supply. However, alarm information is maintained until a clear_faults command is received from the host. For example, the shutdown or OC_fault bits stay in their alarmed state until the host clears the registers.

A clear_faults clears all registers. If a fault still persists after the clear_faults is commanded, the register bit annunciating the fault is reset again

PMBus™ Command set:

Non-supported commands are annunciated.

Command	Hex Code	Data Field	Non-volatile memory storage ⁸ & default
Operation	0x01	1	yes
Clear_Faults	0x03	0	
Write_Protect	0x10	1	no
Restore_default_all	0x12	0	
Restore_default_code	0x14	1	
Store_user_code	0x17	1	yes
Restore_user_code	0x18	1	
Vout_mode	0x20	1	yes
Vout_command	0x21	2	yes
Vin_ON	0x35	2	no
Vin_OFF	0x36	2	no
Fan_config_1_2	0x3A	1	yes
Fan_command_1	0x3B	2	
Vout_OV_fault_limit	0x40	2	yes
Vout_OV_fault_response	0x41	1	yes
Vout_OV_warn_limit	0x42	2	yes
Vout_UV_warn_limit	0x43	2	yes
Vout_UV_fault_limit	0x44	2	yes
Vout_UV_fault_response ⁹	0x45	1	yes
Iout_OC_fault_limit	0x46	2	yes
Iout_OC_fault_response ¹⁰	0x47	1	yes
Iout_OC_LV_fault_limit	0x48	2	yes
Iout_OC_warn_limit	0x4A	2	yes
OT_fault_limit	0x4F	2	yes
OT_fault_response	0x50	1	Yes/CO
OT_warn_limit	0x51	2	yes
Vin_OV_fault_limit	0x55	2	yes
Vin_OV_fault-response	0x56	1	yes
Vin_OV_warn_limit	0x57	2	yes
Vin_UV_warn_limit	0x58	2	yes
Vin_UV_fault_limit	0x59	2	yes
Vin_UV_fault_response	0x5A	1	yes
Status_byte	0x78	1	
Status_word (+ byte)	0x79	1	
Status_Vout	0x7A	1	
Status_Iout	0x7B	1	
Status_Input	0x7C	1	
Status_temperature	0x7D	1	
Status_CML	0x7E	1	
Status_fan_1_2	0x81	1	

⁸ Yes – indicates that the data can be changed by the user

⁹ Only latched (0x80) or restart (0xC0) are supported

¹⁰ Only latched (0xC0) or hiccup (0xF8) are supported

CAR3012TE series front-end

Input: 90Vac to 264Vac; Output: 12 Vdc @ 3000W; 3.3Vdc or 5 Vdc @ 4A

Command	Hex Code	Data Field	Non-volatile memory storage & default
Read_Vin	0x88	2	
Read_lin	0x89	2	
Read_Vout	0x8B	2	
Read_lout	0x8C	2	
Read_temp_PFC	0x8D	2	
Read_temp_dc_primary	0x8E	2	
Read_temp_dc_secondary	0x8F	2	
Read_fan_speed_1	0x90	2	
Read_fan_speed_2	0x91	2	
Read_Pin	0x97	2	
Mfr_ID	0x99	6	Yes
Mfr_model	0x9A	16	Yes
Mfr_revision	0x9B	8	
Mfr_serial	0x9E	16	yes
Status_summary	0xD0	11	
Status_unit	0xD1	2	
Status_alarm	0xD2	3	
Read_fan_speed	0xD3	6	
Read_input	0xD4	5	
Read_firmware_rev	0xD5	6	
Read_run_timer	0xD6	3	
Status_bus	0xD7	1	
Take over bus control	0xD8		
EEPROM Record	0xD9	≤64	yes
Read_temp_exhaust	0xDA	2	
Read_temp_inlet	0xDB	2	
Reserved for factory use	0XDC		
Reserved for factory use	0XDD		
Reserved for factory use	0XDE		
Test Function	0XDF	1	
Upgrade commands			
Password	0xE0	4	
Target_list	0xE1	4	
Compatibility_code	0xE2	32	
Software_version	0xE3	7	
Memory_capability	0xE4	7	
Application_status	0xE5	1	
Boot_loader	0xE6	1	
Data_transfer	0xE7	≤32	
Product comcode	0xE8	11	
Upload_black_box	0xF0	≤32	

Command set adjustment range

If a command is received for a value setting that is outside the range defined below, the module should not change the present setting. The module could NACK the command and set the invalid/unsupported data bit of the status_cml (0x7E) register.

Command	Hex Code	Default HL (LL)	Adjustment range	
			Low	High
Vout_command	0x21	12	10.8	13.2
Fan_command_1	0x3B	-	0	100
Vout_OV_fault_limit	0x40	14.8	10.8	13.2
Vout_OV_warn_limit	0x42	13.8	10.8	13.2
Vout_UV_warn_limit	0x43	10.8	10.8	13.2
Vout_UV_fault_limit	0x44	10	10	13.2
lout_OC_fault_limit	0x46	270	0	270
lout_OC_LV_fault_limit	0x48	7	7	13.2
lout_OC_warn_limit	0x4A	260	0	260
OT_fault_limit	0x4F	130	0	150
OT_warn_limit	0x51	125	0	150
Vin_OV_warn_limit	0x57	265	85	265
Vin_UV_warn_limit	0x58	84	84	265

Command Descriptions

Operation (0x01): By default the Power supply is turned **ON** at power up as long as *Power ON/OFF* signal pin is active HI. The Operation command is used to turn the Power Supply ON or OFF via the PMBus. The data byte below follows the OPERATION command.

FUNCTION	DATA BYTE
Unit ON	80
Unit OFF	00

To **RESET** the power supply cycle the power supply OFF, wait at least 2 seconds, and then turn back ON. All alarms and shutdowns are cleared during a restart.

Clear_faults (0x03): This command clears all STATUS and FAULT registers and resets the Alert# line of both the power supply and I²C bus STATUS register.

If a fault, or a STATUS needing attention, still persists after the issuance of the clear_faults command, the specific registers indicating the fault are reset and the specific Alert# line is activated again.

WRITE_PROTECT register (0x10): Used to control writing to the PMBus device. The intent of this command is to provide protection against accidental changes. All supported command parameters may have their parameters read, regardless of the write_protect settings. The contents of this register can be stored to non-volatile memory using the Store_default_code command. The default setting of this register is enable_all_writes 0x00h.

FUNCTION	DATA BYTE
Enable all writes	00
Disable all writes except write_protect	80
Disable all writes except write_protect and OPERATION	40

Restore_Default_All (0x12): Restores all register values and responses to the default parameters set in the power supply. The factory default cannot be changed.

CAR3012TE series front-end

Input: 90Vac to 264Vac; Output: 12 Vdc @ 3000W; 3.3Vdc or 5 Vdc @ 4A

Restore_default_code (0x14): Restore only a specific register parameter to the factory default parameters set in the power supply.

Store_user_code (0x17): Changes the user default setting of a single register. In this fashion some protection is offered to ensure that only those registers that are desired to be changed are in fact changed.

Restore_user_code (0x18): Restores the user default setting of a single register.

Vout_mode (0x20): This is a 'read only' register. The upper three bits specify the supported data format, in this case Linear mode. The lower five bits specify the exponent of the data in two's complement binary format for output voltage related commands, such as Vout_command. These commands have a 16 bit mantissa. The exponent is fixed by the module and is returned by this command.

Mode	Bits [7:5]	Bits [4:0] (exponent)
Linear	000b	xxxxxb

Vout_Command (0x21) : Used to dynamically change the output voltage of the power supply. This command can also be used to change the factory programmed default set point of the power supply by executing a store-user instruction that changes the user default firmware set point.

The default set point can be overridden by the Vprog signal pin which is designed to override the firmware based default setting during turn ON.

In parallel operation, changing the output voltage should be performed simultaneously to all power supplies using the Global Address (Broadcast) feature. If only a single power supply is instructed to change its output, it may attempt to source all the required power which can cause either a power limit or shutdown condition.

Software programming of output voltage permanently overrides the set point voltage configured by the Vprog signal pin. The program no longer looks at the 'Vprog pin' and will not respond to any hardware voltage settings. If power is removed from the µController it will reset itself into its default configuration looking at the Vprog signal for output voltage control. In many applications, the Vprog pin is used for setting initial conditions, if different than the factory setting. Software programming then takes over once I²C communications are established.

To properly hot-plug a power supply into a live backplane, the system generated voltage should get re-configured into either the factory adjusted firmware level or the voltage level reconfigured by the Vprog pin. Otherwise, the voltage state of the plugged in power supply could be significantly different than the powered system.

Voltage margin range: 10.8Vdc – 13.2 Vdc.

Vin_ON (0x35): This is a 'read only' register that informs the controller at what input voltage level the power supply turns ON. The default value is tabulated in the data section. The value is contingent on whether the power supply operates in the low_line or high_line mode.

Vin_OFF (0x36): This is a 'read only' register that informs the controller at what input voltage level the power supply turns OFF. The default value is tabulated in the data section. The value is contingent on whether the power supply operates in the low_line or high_line mode.

Fan_config_1_2 (0x3A) : This command allows the controller to define whether the fan speed command is in duty cycle or RPM. Both fans must be commanded simultaneously, either by duty cycle or RPM. Mixing controls will result in a 'data error'. The tachometer pulses per revolution is not used.

Fan_command_1 (0x3B): This command instructs the power supply to increase the speed of the fan. The transmitted data byte represents the hex equivalent of the duty cycle in percentage, i.e. 100% = 0x64. The command can only increase fan speed, it cannot instruct the power supply to reduce the fan speed below what the power supply requires for internal control.

Sending 00h tells the power supply to revert back to its internal control.

Vout_OV_fault_limit (0x40): Sets the value at which the main output voltage will shut down. The default OV_fault value is set at 60Vdc.

Vout_OV_fault_response (0x41): This is a 'read only' register. The only allowable state is a latched state after three retry attempts.

An overvoltage shutdown is followed by three attempted restarts, each successive restart delayed 1 second. If within a 1 minute window three attempted restarts failed, the unit will latch OFF. If less than 3 shutdowns occur within the 1 minute window then the count for latch OFF resets and the 1 minute window starts all over again. This performance cannot be changed.

Restart after a latched state: Either of four restart mechanisms is available;

- The hardware pin **ON/OFF** may be cycled OFF and then ON.
- The unit may be commanded to restart via i2c through the *Operation* command by first turning OFF then turning ON .
- The third way to restart is to remove and reinsert the unit.
- The fourth way is to turn OFF and then turn ON ac power to the unit.

A successful restart clears all STATUS and ALARM registers.

A power system that is comprised of a number of power supplies could have difficulty restarting after a shutdown event because of the non-synchronized behavior of the individual power supplies. Implementing the latch-off mechanism permits a synchronized restart that guarantees the simultaneous restart of the entire system.

A synchronous restart can be implemented by;

- Issuing a GLOBAL OFF and then a GLOBAL ON command to all power supplies

CAR3012TE series front-end

Input: 90Vac to 264Vac; Output: 12 Vdc @ 3000W; 3.3Vdc or 5 Vdc @ 4A

- Toggling Off and then ON the **ON/OFF** signal, if this signal is paralleled among the power supplies.
- Removing and reapplying input commercial power to the entire system.

The power supplies should be OFF for at least 20 – 30 seconds in order to discharge all internal bias supplies and reset the soft start circuitry of the individual power supplies.

Vout_OV_warn_limit (0x42): Sets the value at which a warning will be issued that the output voltage is too high.. Exceeding the warning value will set the Alert# signal.

Vout_UV_warn_limit (0x43): Sets the value at which a warning will be issued that the output voltage is too low. Reduction below the warning value will set the Alert# signal.

Vout_UV_fault_limit (0x44): Sets the value at which the power supply will shut down if the output gets below this level. This register is masked if the UV is caused by interruption of the input voltage to the power supply.

Vout_UV_fault_response (0x45): Sets the response if the output voltage falls below the UV_fault_limit. The default UV_fault_response is restart (0xC0). The only two allowable states are latched (0x80) and restart (0xC0)

lout_OC_fault_limit (0x46): Sets the value at which the power supply will shut down. (The value is contingent on whether the power supply operates in the low_line or high_line mode).

lout_OC_fault_response (0x47): Sets the response if the output overload exceeds the OC_Fault_limit value. The default OC_fault_response is hiccup (0xF8). The only two allowable states are latched (0xC0) or hiccup. The response is the same for both low_line and high_line operations.

lout_OC_warn_limit (0x4A): Sets the value at which the power supply issues a warning that the output current is getting too close to the shutdown level. Which level is changed is contingent on the input voltage applied to the power supply at the time the change takes place.

OT_fault_limit (0x4F): Sets the value at which the power supply responds to an OT event, sensed by the dc-sec sensor. The response is defined by the OT_fault_response register.

OT_fault_response (0x50): Sets the response if the output overtemperature exceeds the OT_Fault_limit value. The default OT_fault_response is hiccup (0xC0). The only two allowable states are latched (0x80) or hiccup.

OT_warn_limit (0x51): Sets the value at which the power supply issues a warning when the dc-sec temperature sensor exceeds the warn limit.

Vin_OV_fault_limit (0x55): Sets the value at which the power supply shuts down because the input voltage exceeds the allowable operational limit.

Vin_OV_fault_response (0x56): Sets the response if the input voltage level exceeds the Vin_OV_fault_limit value. The default Vin_OV_fault_response is restart (0xC0). The only two allowable states are latched (0x80) and restart (0xC0).

Vin_UV_warn_limit (0x58): This is another warning flag indicating that the input voltage is decreasing dangerously close to the low input voltage shutdown level.

Vin_UV_fault_limit (0x59): Sets the value at which the power supply shuts down because the input voltage falls below the allowable operational limit.

Vin_UV_fault_response (0x5A): Sets the response if the input voltage level falls below the Vin_UV_fault_limit value. The default Vin_UV_fault_response is restart (0xC0). The only two allowable states are latched (0x80) and restart (0xC0).

STATUS_BYTE (0x78) : Returns one byte of information with a summary of the most critical device faults.

Bit Position	Flag	Default Value
7	Unit is busy	0
6	OUTPUT OFF	0
5	VOUT Overvoltage Fault	0
4	IOUT Overcurrent Fault	0
3	VIN Undervoltage Fault	0
2	Temperature Fault or Warning	0
1	CML (Comm. Memory Fault)	0
0	None of the above	0

STATUS_WORD (0x79): Returns status_byte as the low byte and the following high_byte.

Bit Position	Flag	Default Value
7	VOUT Fault or Warning	0
6	IOUT Fault or Warning	0
5	INPUT Fault or Warning	0
4	MFR SPECIFIC	0
3	POWER_GOOD# (is negated)	0
2	FAN Fault or Warning	0
1	OTHER	0
0	UNKNOWN Fault or Warning	0

CAR3012TE series front-end

Input: 90Vac to 264Vac; Output: 12 Vdc @ 3000W; 3.3Vdc or 5 Vdc @ 4A

STATUS_VOUT (0x7A): Returns one byte of information of output voltage related faults.

Bit Position	Flag	Default Value
7	VOUT OV Fault	0
6	VOUT_OV_WARNING	0
5	VOUT_UV_WARNING	0
4	VOUT UV Fault	0
3 - 0	Not supported	0

STATUS_IOUT (0x7B): Returns one byte of information of output current related faults.

Bit Position	Flag	Default Value
7	IOUT OC Fault	0
6	IOUT OC LV Fault	0
5	IOUT OC Warning	0
4	X	0
3	CURRENT SHARE Fault	0
2	IN POWER LIMITING MODE	0
1 - 0	X	0

STATUS_INPUT (0x7C): Returns one byte of information of input voltage related faults.

Bit Position	Flag	Default Value
7	VIN_OV_Fault	0
6	VIN_OV_Warning	0
5	VIN_UV_Warning	0
4	VIN_UV_Fault	0
3	Unit OFF for low input voltage	0
2	IIN_OC_Fault	0
1 - 0	Not supported	0

STATUS_TEMPERATURE (0x7D): Returns one byte of information of temperature related faults.

Bit Position	Flag	Default Value
7	OT Fault	0
6	OT Warning	0
5 - 0	Not supported	0

STATUS_CML (0x7E): Returns one byte of information of communication related faults.

Bit Position	Flag	Default Value
7	Invalid/Unsupported Command	0
6	Invalid/Unsupported Data	0
5	Packet Error Check Failed	0
4 - 2	Not supported	0
1	Other Communication Fault	0
0	Not supported	0

STATUS_FAN_1_2 (0x81) : Returns one byte of information with a summary of the most critical device faults.

Bit Position	Flag	Default Value
7	Fan 1 Fault	0
6	Fan 2 Fault	0
5 - 4	Not supported	0
3	Fan 1 speed overwritten	0
2	Fan 2 speed overwritten	0
1 - 0	Not supported	0

Read back Descriptions

Single parameter read back: Functions can be read back one at a time using the read_word_protocol with PEC.

Analog data is always transmitted LSB followed by MSB. A NA following the PEC byte signifies that the transmission is complete and is being terminated by the 'host'.

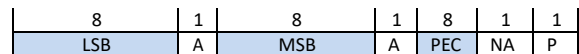
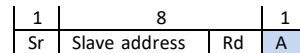
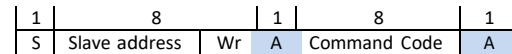

Read back error: If the μ C does not have sufficient time to retrieve the requested data, it has the option to return all FF's instead of incorrect data.

Read_fan_speed 1 & 2 (0x90, 0x91): Reading the fan speed is in Linear Mode returning the RPM value of the fan.

Read_FRU_ID (0x99,0x9A, 0x9E): Returns FRU information. Must be executed one register at a time.

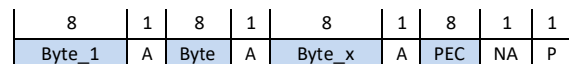

Mfr_ID (0x99): Manufacturer in ASCII – 6 characters maximum, General Electric – Critical Power represented as: GE-CP

Mfr_MODEL (0x9A): Manufacturer model-number in ASCII – 16 characters, for this unit: CAR3012TEBXX201A

Mfr_revision (0x9B): Total 8 bytes, this is the product series taking the form X:YZ. Each byte is in ASCII format. The series number is read from left to right, scanned from the

CAR3012TE series front-end

Input: 90Vac to 264Vac; Output: 12 Vdc @ 3000W; 3.3Vdc or 5 Vdc @ 4A

series number bar code on the power supply. Unused characters are filled at the end with null

Mfr_serial (0x9E): Product serial number includes the manufacturing date, manufacturing location in up to 15 characters. For example:

13KZ51018193xxx, is decoded as;
 13 – year of manufacture, 2013
 KZ – manufacturing location, in this case Matamoros
 51 – week of manufacture
 018193xxx – serial #, mfr choice

Manufacturer-Specific PMBus™ Commands

Many of the manufacturer-specific commands read back more than two bytes. If more than two bytes of data are returned, the standard SMBus™ Block read is utilized. In this process, the Master issues a Write command followed by the data transfer from the power supply. The first byte of the Block Read data field sends back in hex format the number of data bytes, exclusive of the PEC number, that follows. Analog data is always transmitted LSB followed by MSB. A No-ack following the PEC byte signifies that the transmission is complete and is being terminated by the 'host'.

Mfr_Specific Status and alarm registers: The content and partitioning of these registers is significantly different than the standard register set in the PMBus™ specification. More information is provided by these registers and they are either accessed rapidly, at once, using the 'multi parameter' read back scheme of this document, or in batches of two STATUS and two ALARM registers.

Status_summary (0xD0) : This 'manufacturer specific' command is the basic read back returning STATUS and ALARM register data, output voltage, output current, and internal temperature data in a single read. Internal temperature should return the temperature that is closest to a shutdown level.

1	8	1	8	1
S	Slave address	Wr	A	Command Code

1	8	1	8	1
Sr	Slave address	Rd	A	Byte count = 11

8	1	8	1	8	1	8	1
Status-2	A	Status-1	A	Alarm-3	A	Alarm-2	A

8	1	8	1	8	1
Alarm-1	A	Voltage LSB	A	Voltage MSB	A

8	1	8	1
Current-LSB	A	Current-MSB	A

8	1	8	1
Temperature-LSB	A	Temperature-MSB	A

8	1	1
PEC	No-Ack	P

Status_unit(0xD1): This command returns the STATUS-2 and STATUS-1 register values using the standard 'read' format.

Status-2

Bit Position	Flag	Default Value
7	PEC Error	0
6	OC [hiccup=1,latch=0]	1
5	Invalid_Instruction	0
4	Power_Capacity [HL = 1]	x
3	OR'ing Test Failed	0
2	n/a	0
1	Data_out_of_range	0
0	Remote ON/OFF [HI = 1]	x

Oring fault: Triggered either by the host driven or'ing test or by the repetitive testing of this feature within the power supply. A destructive fault would cause an internal shutdown. Success of the host driven test depends on whether the system is N+1 configured.. Thus a non-destructive or'ing fault does not trigger a shutdown.

Status-1

Bit Position	Flag	Default Value
7	OT [Hiccup=1, latch=0]	1
6	OR'ing_Test_OK	0
5	Internal_Fault	0
4	Shutdown	0
3	Service LED ON	0
2	External_Fault	0
1	LEDs_Test_ON	0
0	Output ON (ON = 1)	x

Status_alarm (0xD2): This command returns the ALARM-3 - ALARM-1 register values.

Alarm-3

Bit Position	Flag	Default Value
7	Interlock open	0
6	Fuse fail	0
5	PFC-DC communications fault	0
4	DC-I ² C communications fault	0
3	AC monitor communications fault	0
2	x	0
1	x	0
0	Or'ing fault	0

Alarm-2

Bit Position	Flag	Default Value
7	FAN_Fault	0
6	No_Primary	0
5	Primary_OT	0
4	DC/DC_OT	0
3	Vo lower than BUS	0
2	Thermal sensor filed	0
1	Stby_out_of_limits	0
0	Power_Delivery	0

CAR3012TE series front-end

Input: 90Vac to 264Vac; Output: 12 Vdc @ 3000W; 3.3Vdc or 5 Vdc @ 4A

Power Delivery: If the internal sourced current to the current share current is > 10A, a fault is issued.

Alarm-1

Bit Position	Flag	Default Value
7	POWER LIMIT	0
6	PRIMARY Fault	0
5	OT_Shutdown	0
4	OT_Warning	0
3	IN OVERCURRENT	0
2	OV_Shutdown	0
1	VOUT_out_of_limits	0
0	VIN_out_of_limits	0

Over temperature warning: This flag is set approximately 5°C prior to the commencement of an over temperature shutdown.

Read_Fan_speed (0 x D3) : Returns the commanded speed in percent and the measured speed in RPM. If a fan does not exist, or if the command is not supported the unit return 0x00.

1	8	1	8	1
S	Slave address	Wr	A	Command 0xE1

1	8	1	8	1
Sr	Slave address	Rd	A	Byte count = 6

8	1	8	1	8	1	8	1
Adj%-LSB	A	Adj%-MSB	A	Fan1-LSB	A	Fan1-MSB	A

8	1	8	1	8	1	1
Fan2-LSB	A	Fan2-MSB	A	PEC	No-Ack	P

Read input string (0xD4): Reads back the input voltage and input power consumed by the power supply.

1	7	1	1	8
S	Slave address	Wr	A	Command Code 0xDC

1	1	7	1	1
A	Sr	Slave Address	Rd	A

8	1	8	1	8	1
Byte Count = 4	A	Voltage - LSB	A	Voltage - MSB	A

8	1	8	1	8	1	1
Power - LSB	A	Power - MSB	A	PEC	No-ack	P

Read_firmware_rev [0 x D5]: Reads back the firmware revision of all three µC in the power supply.

1	7	1	1	8	1
S	Slave address	Wr	A	Command Code 0xDD	A

1	1	7	1	1	8	1
A	Sr	Slave Address	Rd	A	Byte Count = 6	A

8	1	8	1
Primary major rev	A	Primary minor rev	A

8	1	8	1
Secondary major rev	A	Secondary minor rev	A

8	1	8	1	8	1	1
I²C major rev	A	I²C revision	A	PEC	No-ack	P

Read_run_timer [0xD6]: This command reads back the recorded operational ON state of the power supply in hours. The operational ON state is accumulated from the time the power supply is initially programmed at the factory. The power supply is in the operational ON state both when in standby and when it delivers main output power.

Recorded capacity is approximately 10 years of operational state.

1	7	1	1	8	1
S	Slave address	Wr	A	Command Code 0xDE	A

1	7	1	1	8	1
Sr	Slave Address	Rd	A	Byte count = 3	A

8	1	8	1	8	1
Time - LSB	A	Time	A	Time - MSB	A

8	1	1
PEC	No-ack	P

Status_bus (0xD7): Bus_Status is a single byte read back. The command can be executed by either master at any time independent of who has control.

The µC may issue a clock stretch, as it can for any other instruction, if it requires a delay because it is busy with other activities.

Automatically resetting into the default state requires the removal of bias supply from the controllers.

Bit Position	Flag	Default Value
7	Bus 1 command error	0
6	Bus 1 Alert# enabled	0
5	Bus 1 requested control	0
4	Bus 1 has control of the PS	0
3	Bus 0 command error	0
2	Bus 0 Alert# enabled	0
1	Bus 0 requested control	0
0	Bus 0 has control of the PS	1

CAR3012TE series front-end

Input: 90Vac to 264Vac; Output: 12 Vdc @ 3000W; 3.3Vdc or 5 Vdc @ 4A

Command Execution: The master not in control can issue two commands on the bus, take_over_bus_control and clear_faults

Take_over_Bus_Control (0xD8): This command instructs the internal µC to switch command control over to the 'master' that initiated the request.

Actual transfer is controlled by the I²C selector section of the µC. A bus transfer only occurs during an idle state when the 'master' currently in control (in the execution process of a control command) has released the bus by issuing a STOP command. Control can be transferred at any time if the 'master' being released is executing a read instruction that does not affect the transfer of command control. Note; The µC can handle read instructions from both busses simultaneously.

The command follows PMBus™ standards and it is not executed until the trailing PEC is validated.

Status Notifications: Once control is transferred both Alert# lines should get asserted by the I²C selector section of the µC. The released 'master' is notified that a STATUS change occurred and he is no longer in control. The connected 'master' is notified that he is in control and he can issue commands to the power supply. Each master must issue a clear_faults command to clear his Alert# signal.

If the Alert# signal was actually triggered by the power supply and not the I²C selector section of the µC, then only the 'master' in control can clear the power supply registers.

Incomplete transmissions should not occur on either bus.

EEPROM record (0xD9): The µC contains 64 bytes of reserved EEPROM space for customer use. After the command code, the starting memory location must be entered followed by a block write, and terminated by the PEC number;

1	7	1	1	8	1
S	Slave address	Wr	A	Command Code 0xD9	A

8	1	8	1
Start location	A	Byte count	A

8	1	8	1
first_byte	Alast - byte	A

8	1	1
PEC	A	P

To read contents from the EEPROM space

1	7	1	1	8	1
S	Slave address	Wr	A	Command 0xD9	A

8	1	8	1
Memory location	A	Byte count ≤ 32	A

1	7	1	1
Sr	Slave address	Rd	A

8	1	8	1
Byte 1	AByte ≤ 32	A

8	1	1
PEC	No-ack	P

Test Function (0xDF): This command can be used to exercise the LEDs of the power supply and verify the functionality of the output Or'ing feature of the power supply.

Bit	Function	State
7	25ms stretch for factory use	1= stretch ON
5 - 6	reserved	
4	Or'ing test	1=ON, 0=OFF
2 - 3	reserved	
1	reserved	
0	LED test	1=ON, 0=OFF

LEDS test ON: Will turn-ON simultaneously the front panel LEDs of the Power supply sequentially 7 seconds ON and 2 seconds OFF until instructed to turn OFF. The intent of this function is to provide visual identification of the power supply being talked to and also to visually verify that the LEDs operate and driven properly by the micro controller.

LEDS test OFF: Will turn-OFF simultaneously the four front panel LEDs of the Power supply.

OR'ing Test: This command verifies functioning of output OR'ing. At least two paralleled power supplies are required. The host should verify that N+1 redundancy is established. If N+1 redundancy is not established the test can fail. Only one power supply should be tested at a time.

Verifying test completion should be delayed for approximately 30 seconds to allow the power supply sufficient time to properly execute the test.

Failure of the isolation test is not considered a power supply FAULT because the N+1 redundancy requirement cannot be verified. The user must determine whether a true isolation fault indeed exists.

General performance descriptions

Default state: Power supplies are programmed in the default state to automatically restart after a shutdown has

CAR3012TE series front-end

Input: 90Vac to 264Vac; Output: 12 Vdc @ 3000W; 3.3Vdc or 5 Vdc @ 4A

occurred. The default state can be reconfigured by changing non-volatile memory (Store_user_code).

Delayed overcurrent shutdown during startup: Power supplies are programmed to stay in a constant current state for up to 20 seconds during power up. This delay has been introduced to permit the orderly application of input power to a subset of paralleled power supplies during power up. If the overload persists beyond the 20 second delay, the power supply will revert back into its programmed state of overload protection.

Unit in Power Limit or in Current Limit: When output voltage is > 10V_{DC} the Output LED will continue blinking. When output voltage is < 10V_{DC}, if the unit is in the RESTART mode, it goes into hiccup. When the unit is ON the output LED is ON, when the unit is OFF the output LED is OFF.

Restart after a latchoff: PMBus™ fault_response commands can be configured to direct the power supply to remain latched off for over_voltage, over_temperature and over_current.

To restart after a latch off either of five restart mechanisms are available.

1. The hardware pin **ON/OFF** may be cycled OFF and then ON.
2. The unit may be commanded to restart via I²C through the *Operation* command by cycling the output OFF followed by ON.
3. Remove and reinsert the unit.
4. Turn OFF and then turn ON AC power to the unit.
5. Changing firmware from **latch off to restart**.

Each of these commands must keep the power supply in the OFF state for at least 2 seconds, with the exception of changing to **restart**.

A successful restart shall clear all alarm registers, set the **restarted successful** bit of the *Status_2* register.

A power system that is comprised of a number of power supplies could have difficulty restarting after a shutdown event because of the non-synchronized behavior of the individual power supplies. Implementing the latch-off mechanism permits a synchronized restart that guarantees the simultaneous restart of the entire system.

A synchronous restart can be implemented by;

1. Issuing a GLOBAL OFF and then ON command to all power supplies,
2. Toggling Off and then ON the ON/OFF (ENABLE) signal
3. Removing and reapplying input commercial power to the entire system.

The power supplies should be turned OFF for at least 20 – 30 seconds in order to discharge all internal bias supplies and reset the soft start circuitry of the individual power supplies.

Auto_restart: Auto-restart is the default configuration for over-current and over-temperature shutdowns. These

features are configured by the PMBus™ fault_response commands

An overvoltage shutdown is followed by three attempted restarts, each restart delayed 1 second, within a 1 minute window. If within the 1 minute window three attempted restarts failed, the unit will latch OFF. If within the 1 minute less than 3 shutdowns occurred then the count for latch OFF resets and the 1 minute window starts all over again

Fault management

Certain transitional states can occur before a final state is reached. The STATUS and ALARM registers will not be frozen into a notification state until the final state is reached. Once a final state is reached the Alert# signal is set and the STATUS and ALARM registers will not get reinstated until a clear_faults is issued by the master. The only exception is that additional state changes may be added to the original list if further changes are noted.

All fault information is sticky. If the fault still persists after a clear_faults has been issued, then the fault state will reassert. All operational state information is not sticky.

The power supply differentiates between **internal faults** that are within the power supply and **external faults** that the power supply protects itself from, such as overload or input voltage out of limits. The FAULT LED, FAULT PIN or i2c alarm is not asserted for EXTERNAL FAULTS. Every attempt is made to annunciate External Faults. Some of these annunciations can be observed by looking at the input LEDs. These fault categorizations are predictive in nature and therefore there is a likelihood that a categorization may not have been made correctly.

Input voltage out of range: The Input LED will continue blinking as long as sufficient power is available to power the LED. If the input voltage is completely gone the Input LED is OFF.

State change definition

A **state_change** is an indication that an event has occurred that the MASTER should be aware of. The following events shall trigger a **state_change**;

- Initial power-up of the system when AC gets turned ON . This is the indication from the power supply that it has been turned ON.
- Whenever the power supply gets hot-plugged into a working system. This is the indicator to the system (MASTER) that a new power supply is on line.
- Any changes in the bit patterns of the STATUS and ALARM registers are a STATUS change which triggers the ALERT# flag.

CAR3012TE series front-end

Input: 90Vac to 264Vac; Output: 12 Vdc @ 3000W; 3.3Vdc or 5 Vdc @ 4A

Note that a host-issued command such as turning the output OFF will not trigger an Alert# even though the STATUS registers will change to indicate the latest state of the power supply.

Communications during hot plug

Careful system control is recommended when hot plugging a power supply into a live system. It takes about 15 seconds for a power supply to configure its address on the bus based on the analog voltage levels present on the backplane. If communications are not stopped during this interval, multiple power supplies may respond to specific instructions because the address of the hot plugged power supply always defaults to xxxx000 (depending on which device is being addressed within the power supply) until the power supply configures its address.

The recommended procedure for hot plug is the following: The system controller should poll the module_present signal to verify when a power supply is inserted into the system. When a new module is detected the system controller should cease any communications with the power system for 15 seconds. At the end of the time out all communications can resume. Note that although hot-plug should not affect ongoing communications, if a discrepancy should arise the error should get picked up by the PEC calculation. Ofcourse the system controller could always use the module_present signal as an indicator to ignore communications that are currently taking place.

Failure Predictions

Alarm warnings that do not cause a shutdown are indicators of potential future failures of the power supply. For example, if a thermal sensor failed, a warning is issued but an immediate shutdown of the power supply is not warranted.

Another example of potential predictive failure mechanisms can be derived from information such as fan speed when multiple fans are used in the same power supply. If the speed of the fans varies by more than 20% from each other, this is an indication of an impending fan wear out.

The goal is to identify problems early before a protective shutdown would occur that would take the power supply out of service.

Information only alarms: The following alarms are for information only, they do not cause a shutdown

- Over temperature warning
- V_{out} out-of-limits
- Output voltage lower than bus
- Unit in Power Limit
- Thermal sensor failed
- Or'ing (Isolation) test failure
- Power delivery
- Stby out of limits
- Communication errors

LEDs

Two LEDs are located on the front faceplate. The AC_OK LED provides visual indication of the INPUT signal function. When the LED is ON GREEN the power supply input is within normal design limits.

The second LED DC/FLT is a dual-state LED. When GREEN there are no faults and DC output is present. When 'blinking' a fault condition exists but the power supply may still provide some output power. When RED, a fault condition exists and the power supply has been shut down, it does not provide any output power.

Remote upgrade

This section describes at a high-level the recommended re-programming process for the three internal micro controllers inside the power supply when the re-programming is implemented in live, running, systems.

The process has been implemented in visual basic by GE Critical Power for controller based systems positioned primarily for the telecommunications industry. GE Critical Power will share its development with customers who are interested to deploy the re-programming capability into their own controllers.

For some customers' internal system re-programming is either not feasible or not desired. These customers may obtain a re-programming kit from GE Critical Power. This kit contains a turn-key package with the re-program firmware.

In-system remote upgrade

Conceptual Description: The power supply contains three independent μ Controllers. The boost (PFC) section is controlled by the primary μ Controller. The secondary DC-DC converter is controlled by the secondary μ Controller, and I²C communications are being handled by the I²C Interface μ Controller.

Each of the μ Controllers contains a **boot loader** section and an **application** section in memory. The purpose of the boot loader section is to facilitate the upgrading capability described here. All the commands for upgrading and memory space required for incrementally changing the application code are in this section. The application section contains the running code of the power supply.

The system controller receives the upgrade package. It should first check whether an upgrade is required followed by upgrading those processors, one at a time, that are required to be upgraded. Each processor upgrade needs to be validated and once the upgrade is successfully completed the boot loader within each processor will permit the application to run after a reset. If the validation fails the boot loader will stay in its section. The system controller can attempt another upgrade session to see if it would complete successfully.

CAR3012TE series front-end

Input: 90Vac to 264Vac; Output: 12 Vdc @ 3000W; 3.3Vdc or 5 Vdc @ 4A

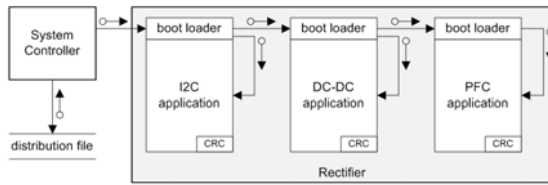

The Upgrade Package: This package contains the following files;

- Manifest.txt** - The manifest describes the contents of the upgrade package and any incidental information that may be useful, for example, what this upgrade contains or why is this upgrade necessary

 This file contains the version number and the compatibility code of the upgraded program for each of the three processors
- Program.bin** - The upgraded program contents are located here. Each processor to be upgraded will have its own file.

Below is an example of an upgrade package

- Contents of the upgrade are in a zip file CAR3012TExxxZ01A.zip
- Unzipping the contents shows the following files
 CAR3012TExxxZ01A.pfc.bin
 CAR3012TExxxZ01A.sec.bin
 CAR3012TExxxZ01A.iic.bin
 manifest.txt
- Opening manifest.txt shows the following

```
# Upgrade manifest file
# Targets: CAR3012TExxxZ01A PFC and SEC
# Date: Tue 01/14/2014 14:25:09.37
# Notes:
>p,CAR3012TE_P01, CAR3012TExxxZ01A_PFC.bin,1.18
>s,CAR3012TE_S01, CAR3012TExxxZ01A_SEC.bin,1.1
>i, CAR3012TE_I01, CAR3012TExxxZ01A_IIC.bin,2.5
```

↑
↑
↑
 compatibility code, new program, revision number

Upgrade Status Indication: The FAULT LED is utilized for indicating the status of the re-programming process.

Status	Fault LED	Description
Idle	OFF	Normal state
In boot block	Wink	Application is good
Upgrading	Fast blink	Application is erased or programming in progress
Fault	ON	Erase or re-program failed

Wink: 0.25 seconds ON, 0.75 seconds OFF
 Fast Blink: 0.25 seconds ON. 0.25 seconds OFF

Upgrade procedure

- Initialization: To execute the re-programming/upgrade in the system, the power supply to be re-programmed must first be taken OFF-line prior to executing the upgrade.

Note: If the power supply is not taken OFF-line by the system controller, the boot loader will turn OFF the output prior to continuing with the re-programming operation.

Make sure that sufficient power is provided by the remaining on-line power supplies so that system functionality is not jeopardized.

- Unzip the distribution file
- Unlock upgrade execution protection by issuing the command below;

Password(0xE0): This command unlocks the upgrade commands feature of the power supply by sending the characters 'UPGD'.

1	8	1	8	1	8	1	
S	Slave addr	Wr	A	Cmd - 0xE0	A	Byte count - 4	A

8	1	8	1	8	1	1	
Byte 0 - U	A	Byte 4 - D	A	PEC	A	P

- None of the upgrade commands in a processor can be executed until that processor is placed into boot block mode. To enter boot block mode, the Boot Loader (0xE6) command must be executed next with the instruction for the processor to enter boot block - data: 1=enter boot block.

The sequence for the upgrade is as follows:

- enter the processor into boot block
- erase the application
- execute the upgrade
- exit from the processor boot block

This sequence needs to be repeated for each processor. The sequence of upgrade does not matter if all processors are properly upgraded. The following instructions describe each of the commands.

Perform the checks and balances, status verifications, sequence verifications, and validation error checking.

CAR3012TE series front-end

Input: 90Vac to 264Vac; Output: 12 Vdc @ 3000W; 3.3Vdc or 5 Vdc @ 4A

Boot loader (0xE6): This command manages the upgrade process starting with entering the sector, erasing the present application, indicating completion of the upload and finally exiting from the boot sector, thereby turning over control to the uploaded application.

1	7	7	7	8		8	
S	Slave addr	Wr	A	Cmd – 0xE6		Target-x	

8	1	8	1	1
Data	A	PEC	A	P

Data:
 1=enter boot block (software reboot)
 2=erase
 3=done
 4=exit¹¹ boot block (watchdog reboot)

Notes: During this process if the output of the power supply was not turned OFF the boot loader will turn OFF the output.

Entering boot loader must be a sequential set of instructions. The iic processor must be entered first, followed by entering the boot loader of the secondary processor and finally the primary processor. Both the iic and the secondary processor must be maintained in boot loader while communicating to the primary processor.

Entering the primary or secondary boot loaders is not needed if only the iic processor is being upgraded.

Wait at least 1 second after issuing an *erase* command to allow the µC to complete its task.

Use command 0xE5 to verify that the PFC µC is erased. The returned status byte should be 0x81.

Use the Data Transfer command to update the application of the target µC.

- 5. Obtain a list of upgradable processors (optional)

Target list(0xE1) : This command returns the upgradable processors within the power supply. The byte word is the ASCII character of the processor (p, s, and i). The command is optional to the user for information only.

1	8	1	8	1
S	Slave addr	Wr	A	Cmd – 0xE1

1	8	1	8	1
Sr	Slave addr	Rd	A	Byte count - n

8	1	8	1	8	1	1
Byte 0	A	Byte n	A	PEC	No-Ack
						P

Potential target processors are the following:

- p – primary (PFC)
- s – secondary (DC-DC)
- i – I²C

- 6. Verify upgrade compatibility by matching the upgrade compatibility code in the manifest.txt file to the power supply compatibility code of the target processor.

Compatibility code (0xE2): The compatibility code consists of up to 32 characters defining the hardware configuration. To read the compatibility codes of each processor in the module execute the following read:

1	8	1	8	1	8	1
S	Slave addr	Wr	A	Cmd – 0xE2	Target-x	

1	8	1	8	1	8	1
Sr	Slave addr	Rd	A	Byte count = 32	A	Byte 0
						A

8	1	8	1	1
Byte 31	A	PEC	No-Ack	P

Where Target-x is an ASCII character pointing to the processor to be updated;

- p – primary (PFC)
- s – secondary (DC-DC)
- i – I²C

- 7. Check the software revision number of the target processor in the power supply and compare it to the revision in the upgrade. If the revision numbers are the same, or the power supply has a higher revision number then no upgrade is required for the target processor.

Software revision(0xE3): This command returns the software revision of the target.

1	8	1	8	1	8	1
S	Slave addr	Wr	A	Cmd – 0xE3	Target-x	A

1	8	1	8	1	8	1
Sr	Slave addr	Rd	A	Byte count=7	A	Major revision
						A

8	1	8	1	8	1	8	1
Minor revision	A	month	A	day	A	year ¹²	A

8	1	8	1	8	1	1
hrs	A	min	A	PEC	No-Ack	P

¹¹ The ‘exit boot block’ command is only successful if all applications are valid, otherwise, control remains in the boot block

¹² Last two digits

CAR3012TE series front-end

Input: 90Vac to 264Vac; Output: 12 Vdc @ 3000W; 3.3Vdc or 5 Vdc @ 4A

8. Verify the capability of each processor

Memory capability (0xE4): Provides the specifics of the capability of the device to be reprogrammed

1	8	1	8	1	8	1	
S	Slave addr	Wr	A	Cmd - 0xE4	A	Target-x	A

1	8	1	8	1	8	1	
Sr	Slave addr	Rd	A	Byte count=7	A	Max bytes	A

8	1	8	1	8	1	8	1
ET-LSB	A	ET-MSB	A	BT-LSB	A	BT-MSB	A

8	1	8	1	8	1	1
App_CRC_LSB	A	App_CRC_MSB	A	PEC	No-Ack	P

Where the fields definition are shown as below:

Max Bytes	Maximum number of bytes in a data packet
ET	Erase time for entire application space (in mS)
BT	Data packet write execution time (uS)
APP_CRC	returns the application CRC-16 calculation.

This information should be used by the host processor to determine the max data packet size and add appropriate delays between commands.

9. Determine the status of the upgrade: The Application status command is used to verify the present state of the boot loader.

Application status (0xE5): Returns the Boot Loader's present status

1	8	1	8	1	8	1	
S	Slave addr	Wr	A	Cmd - 0xE5	A	Target-x	A

1	8	1	8	1	8	1	1	
Sr	Slave addr	Rd	A	Status	A	PEC	No-Ack	P

Status bits:

0x00	Processor is available	0x10	Reserved
0x01	Application erased	0x20	Reserved
0x02	CRC-16 invalid	0x40	Manages downstream uC
0x04	Sequence out of order	0x80	In boot loader
0x08	Address out of range		

Status of the application should be checked after the execution of successive commands to verify that the commands have been properly executed.

Data transfer (0xE7): The process starts with uploading data packets with the first sequence number (0x0000). Both the write and read commands need to include the target-x processor.

Data transfer [write]

1	8	1	8	1	8	1	
S	Slave addr	Wr	A	Cmd - 0xE7	A	Target-x	A

8	1	8	1	8	1
Seq-LSB	A	Seq-MSB	A	Byte Count = n	A

8	1	8	1	8	1	1
Byte 0	A	Byte n-1	A	PEC	A	P

After completion of the first data packet upload the Boot loader increments the sequence number. A subsequent read to the boot loader will return the incremented sequence number and a STATUS byte. This is a validity check to ensure that the sequence number is properly kept. The returned STATUS byte is the same as the application status response. It is appended here automatically to save the execution of another command. It should be checked to ensure that no errors are flagged by the boot loader during the download. If an error occurred, terminate the download load and attempt to reprogram again.

Data transfer [read]

Note: Reading the sequence number needs to be delayed approximately 150ms after uploading a data packet in order to allow the processor to update the sequence number field.

1	8	1	8	1	8	1	
S	Slave addr	Wr	A	Cmd - 0xE7	A	Target-x	A

1	8	1						
Sr	Slave addr	Rd	A					
1	8	8	1	8	1	8	1	1
Seq-LSB	A	Seq-MSB	A	Status	A	PEC	No-Ack	P

The returned Status byte is defined in the Application Status command (0 x E5).

Sequence number validation should take place after each data block transfer. The next data block transfer starts with the sequence number received from the boot loader.

The host keeps track of the upload and knows when the upload is completed.

10. Execute a Boot loader command to tell the uC that the transfer is done.

At the completion signal, the uC should calculate the PEC value of the entire application. The last two bytes of the loaded application were the CRC-16 based PEC calculation.

Wait for at least 1 second to allow time for the uC to calculate the error checking value.

11. Execute an Application status command to verify that the error check is valid. The returned status should be 0x80.

CAR3012TE series front-end

Input: 90Vac to 264Vac; Output: 12 Vdc @ 3000W; 3.3Vdc or 5 Vdc @ 4A

12. Execute a Boot loader command to exit boot block. Upon receipt of the command the μ C will transfer to the uploaded application code.
13. Wait for at least 1 second.
14. Use command 0xE1 to verify that the μ C is now in the application code. The returned status data byte should be 0x00.
15. Repeat the program upgrade for other μ C's, if included in the upgrade package.

Product comcode

Although the comcode number is not required for the upgrade process in its present form, it may be useful when upgrading multiple version of the same product in order to differentiate product upgrade requirements.

Product comcode (0xE8):

1	8	1	8	1
S	Slave addr	Wr	A	Cmd - 0xE8

1	8	1	8	1
Sr	Slave addr	Rd	A	Byte count = 11

8	1	8	1	8	1	1
Byte 0	A	Byte 10	A	PEC	No-Ack

Error handling: The Boot loader will not start the application if errors occurred during the re-program stage. The controlling program could restart the upgrade process or terminate the upgrade and remove the offending power supply from service.

If a transmission error occurs, or if the μ C did not receive the data from the DSP, the μ C may set the length to 0, issue a PEC and terminate the transmission.

Timing recommendation:

- 2ms delay prior to issuing a read address (address[R])
- 30ms delay between commands
- 1s delay after issuing a store_user_code command
- 5s delay after issuing a restore_default_all command
- 3s delay for a retry if the power supply does not respond to its address (allows for a RESET condition).

Black box

Contents of the black box and more detailed information about the specifics of the feature are described in a separate document. The intent here is to provide a high level summary. This feature includes the following;

1. A rolling event Recorder
2. Operational Use Statistics

The rolling event recorder

The purpose of the black box is to provide operational statistics as well as fault retention for diagnostics following either recoverable or non-recoverable fault events. Sufficient memory exists to store up to 5 time-stamped snapshot records (pages) that include the state of the status and alarm registers and numerous internal measurement points within the power supply. Each record is stored into nonvolatile memory at the time when a black box trigger event occurs. Once five records are stored, additional records over-write the oldest record.

The memory locations will be cleared, when the product is shipped from the GE factory.

Operational use statistics

This feature of the black box includes information on the repetition and duration of certain events in order to understand the long-term operational state of the power supply. The events are placed into defined buckets for further analysis. For example; the power supply records how long was the output current provided in certain load ranges.

Accessing the event records

The event records are accessed by uploading the entire contents of the black box of the power supply into a folder assigned by the user. Within the I²C protocol this upload is accomplished by the upload_black_box (0xF0) command described below. GE provides a Graphical User Interface (GUI) that de-codes the contents of the black box into a set of records that can be reviewed by the user.

CAR3012TE series front-end

Input: 90Vac to 264Vac; Output: 12 Vdc @ 3000W; 3.3Vdc or 5 Vdc @ 4A

Upload black box(0xF0): This command executes the upload from the power supply to a file of the user's choice.

The 100ms delay prior to the restart is mandatory to provide enough time for the power supply to gather the required data from the secondary DSP controller.

1	8	1	8	1
S	Slave addr	Wr	A	Cmd - 0xF0

8	1	8	1
Start address - msb	A	Start address - lsb	A

8	1
Length = N (≤ 32)	A

..... delay 100ms

1	8	1	8	1	8	1
Sr	Slave addr	Rd	A	Length ≤ 32	A	Byte 0

8	1	8	1	1
Byte N-1	A	PEC	No-Ack	P

If a transmission error occurs, or if the uC did not receive the data from the DSP, the uC may set the length to 0, issue a PEC and terminate the transmission.

The data array supported by rev 1.3 of the GE Interface Adapter is 32 x 64 comprising 2048 bytes of data.

Start
 Address 0 Byte 31
 0000h
 0020h
 0040h
 .
 .
 .
 .
 .
 .
 .
 .
 .
 07E0h

CAR3012TE series front-end

Input: 90Vac to 264Vac; Output: 12Vdc @ 3000W; 3.3 or 5Vdc @ 4A Standby

Alarm Table

Test Condition		LED Indicator			Monitoring Signals			
		LED1 INPUT OK	Dual-Color LED2 Temp OK/PG#/ Fault		FAULT	PG#	INPUT OK	TEMP OK
1	Normal Operation	Green	Green		High	High	High	High
2	Out of range INPUT	Blinking	OFF		High	Low	Pulsing	High
3	No Input	OFF	OFF		High	Low	Low	High
4	OVP	Green	Red		Low	Low	High	High
5	Over Current	Green	Blinking		High	Pulsing	High	High
6	Over Temp Warning	Green	Blinking Red		High	High	High	Pulsing
7	Over Temp Fault	Green	Red		Low	Low	High	Low
8	Remote ON	Green	Green		High	High	High	High
9	Remote OFF	Green	OFF		High	Low	High	High

Notes: Test condition #2 and #3 had 2 modules plug in. One module is running and the other one is with no/low AC.

Test condition #5, The PG# signal responds to two independent conditions. It can activate either for loss of output because of an overload condition, or it can activate because of the impending loss of output voltage because input power has been interrupted. In case of an overload condition, depending on how deep is the overload, sufficient holdup may not be present to provide the required delay prior to the regulation going below 10.8 V_{DC}.

Blinking of the overload LED will not occur until the output voltage decayed about 0.3V from its regulation point. During hiccup, blinking occurs only during the ON-time state.

Blinking frequency: 0.5 seconds ON, 0.5 seconds OFF.

CAR3012TE series front-end

Input: 90Vac to 264Vac; Output: 12Vdc @ 3000W; 3.3 or 5Vdc @ 4A Standby

Outline Drawing

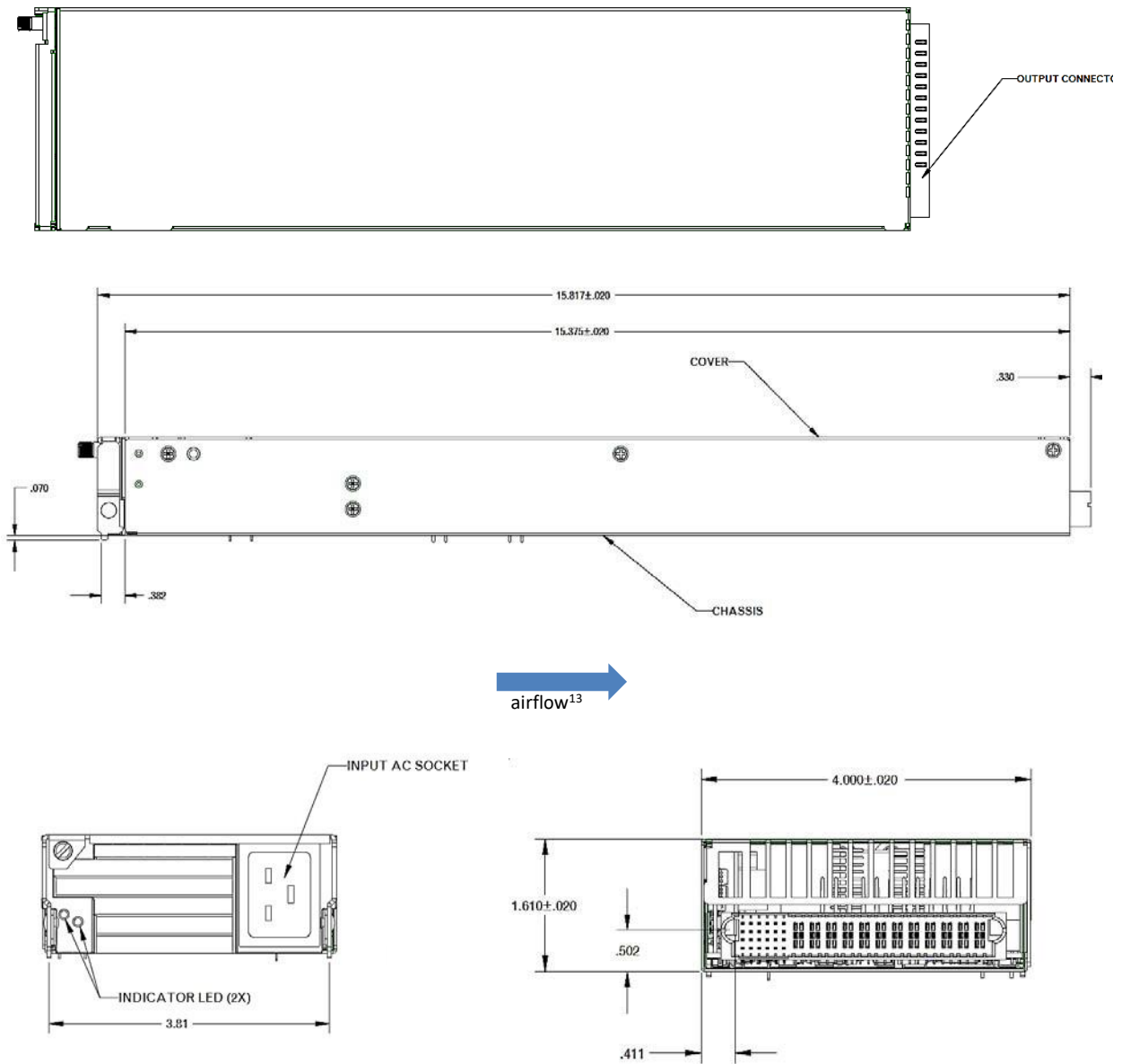

Connector Pin Assignments

¹³ Reverse airflow capability/performance should be evaluated using the standard IEC connector and the capability improvement if the input connector is changed to the high temperature connector. (fan temperature should also be verified carefully).

CAR3012TE series front-end

Input: 90Vac to 264Vac; Output: 12Vdc @ 3000W; 3.3 or 5Vdc @ 4A Standby

Input Connector: IEC320, C20; mating connector: IEC320, C19 type

Output Connector: FCI Berg P/N 10106132-C006001, TE 2-6450831-3 or equivalent
 Mating connector: FCI Berg P/N 10106135-C006001, TE 1-6450871-1 (right angle)
 FCI Berg P/N 10106137-C006001 (in line)

PART NUMBER	ROWS	SIGNAL						POWER												
		I	2	3	4	5	6	P1	P2	P3	P4	P5	P6	P7	P8	P9	P10	P11	P12	
2-6450831-3	D	J	J	J	J	J	J	TM	TM	TM	TM	TM	TM	TM	TM	TM	TM	TM	TM	TM
	C	F	K	K	K	K	K													
	B	N	G	G	N	N	N													
	A	H	S	S	S	H	S													
24S + 12HDP																				

Power Supply output connector shown above: Short (MLBF) signal pins: F, G, H
 Standard signal pins: J, K, N, S

Mating connector: Long power (MFBL) socket: P1 through P6
 Standard power socket: P7 – P12

Pin	Function	Pin	Function	Pin	Function	Pin	Function				
A1	Vstb	B1	Fault#	C1	IShare	D1	VProg				
A2	Logic_GRD	B2	8V_INT	C2	Alert#_1	D2	Unit_ID				
A3	SDA-1	B3	Interlock	C3	OTW#	D3	Remote ON/OFF				
A4	SCL-1	B4	PS Present	C4	RS_485+	D4	PG#				
A5	Remote Sense (+)	B5	SDA -0	C5	RS_485-	D5	Protocol				
A6	Remote Sense (-)	B6	SCL -0	C6	Rack_ID	D6	Alert#_0				
P1 – P6						Output Return		P7– P12		+12Vout	

Short signal pins are to be changed to when connector is available
 RS_485+, RS_485-, Protocol are for internal test use only. Do not connect to anything.

CAR3012TE series front-end

Input: 90Vac to 264Vac; Output: 12Vdc @ 3000W; 3.3 or 5Vdc @ 4A Standby

Ordering Information

Please contact your GE Sales Representative for pricing, availability and optional features.

PRODUCT	DESCRIPTION	PART NUMBER
3000W Front-End	+12Vout , 3.3Vsb, face plate, PMBus interface, RoHS 6 of 6	CAR3012TEBXXZ01A
3000W Front-End	+12Vout , 5Vsb, face plate, PMBus interface, RoHS 6 of 6	CAR3012TEBX5Z01A
3000W Front-End	+12Vout , 3.3Vsb, face plate, PMBus interface, reverse airflow, RoHS 6 of 6	CAR3012TEBCRZ01A
3000W Front-End	+12Vout , 5Vsb, face plate, PMBus interface, reverse airflow, RoHS 6 of 6	CAR3012TEBR5Z01A

Contact Us

For more information, call us at

USA/Canada:

+1 888 546 3243, or +1 972 244 9288

Asia-Pacific:

+86-21-53899666

Europe, Middle-East and Africa:

+49.89.878067-280

[Go.ABB/Industrial](#)



imagination at work

GE Critical Power reserves the right to make changes to the product(s) or information contained herein without notice, and no liability is assumed as a result of their use or application. No rights under any patent accompany the sale of any such product(s) or information.