

TOP VIEW

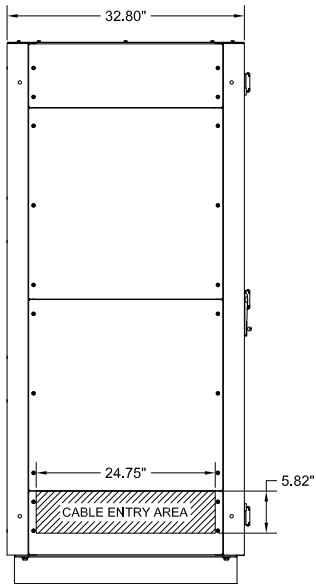

LEFT SIDE VIEW

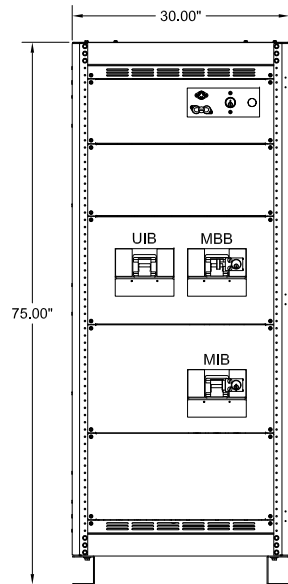

FRONT VIEW
(DOOR REMOVED)

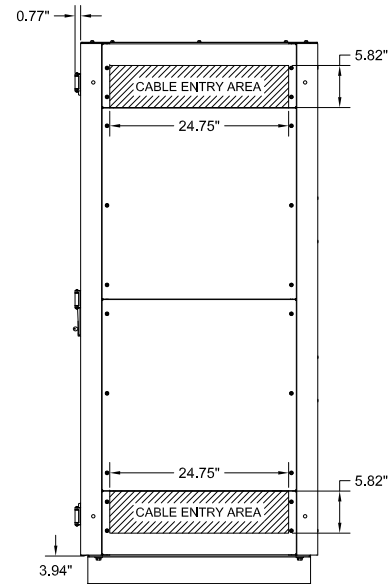

RIGHT SIDE VIEW

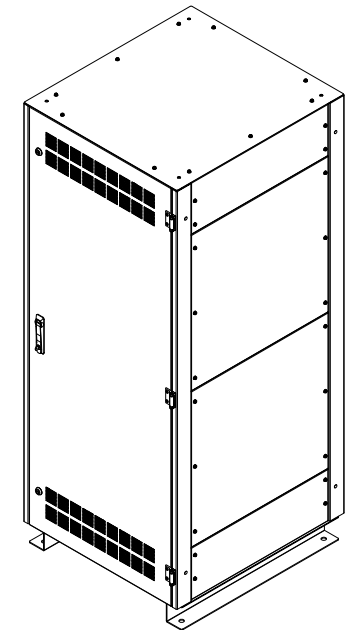

ISOMETRIC VIEW

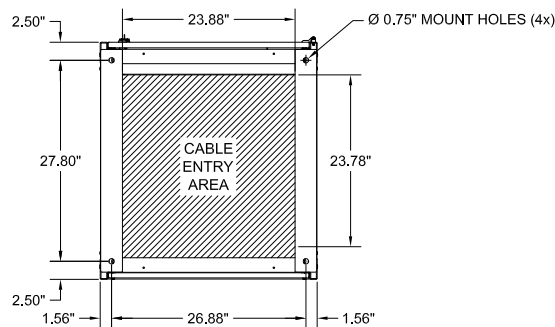

BOTTOM VIEW

- NOTES:
1. APPROXIMATE WEIGHT: 560 LBS.
 2. ASSEMBLY IS UL/CUL LISTED TO UL 891 AND C22.2 NO. 244.
 3. NEMA 1 TYPE ENCLOSURE.
 4. THE CABINET IS CONSTRUCTED FROM GALVANIZED STEEL.
 5. THE CABINET IS TO BE MOUNTED THROUGH THE 0.750" HOLES IN THE CABINET LEGS. THE LEGS ARE FORMED FROM 10 GAUGE STEEL.
 6. FINISH IS POWDER COAT ON ALL EXTERNAL AND VISIBLE SURFACES. INTERIOR PANELS AND MOUNT BRACKETS ARE GALVANIZED FINISH.
 7. CABINET LEGS ARE REVERSIBLE FOR EASY ACCESS TO CABINET FLOOR MOUNTING HARDWARE.

MAINTENANCE BYPASS CABINET FOR TLE SERIES UPS 250-400KVA, 277V/480V, 3Ø/4W/G, 3 BREAKER WITH SKRU INTERLOCK CONFIGURATION 12			
<small>THE INFORMATION CONTAINED IN THIS DRAWING IS THE SOLE PROPERTY OF C&C POWER, INC. ANY REPRODUCTION WITHOUT THE WRITTEN CONSENT OF C&C POWER, INC IS PROHIBITED.</small>			
<small>DIMENSIONS ARE IN INCHES</small>		<small>INITIALS</small> <small>TD</small>	<small>DATE</small> <small>8/22/2019</small>
<small>TOLERANCES:</small> <small>DECIMALS: .XX ±.13</small> <small>ANGLES: .XXX ±.082</small>	<small>±1"</small>	<small>CHECKED</small> <small>CH</small>	<small>SCALE: SIZE: A</small> <small>REV: 8</small>
<small>NTS</small>		SHEET 1 OF 2	 <small>Electrification's Product Group</small> <small>EP Industrial Solutions Division</small> <small>Manufactured by C&C Power for ABB</small> <small>© 2017 C&C POWER, INC. ALL RIGHTS RESERVED</small>

DRAWING # 9837-FC12-SD01-1 REV 8