

TOP VIEW

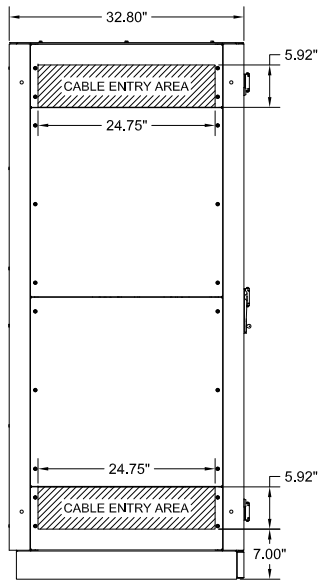

LEFT SIDE VIEW

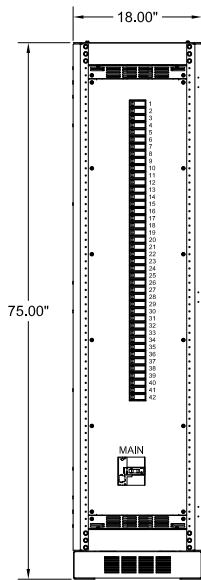

FRONT VIEW  
42 CIRCUIT PANEL  
(DOOR REMOVED)

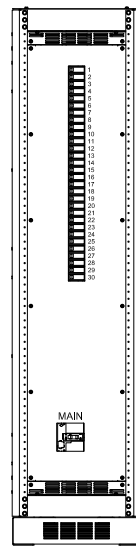

FRONT VIEW  
30 CIRCUIT PANEL  
(DOOR REMOVED)

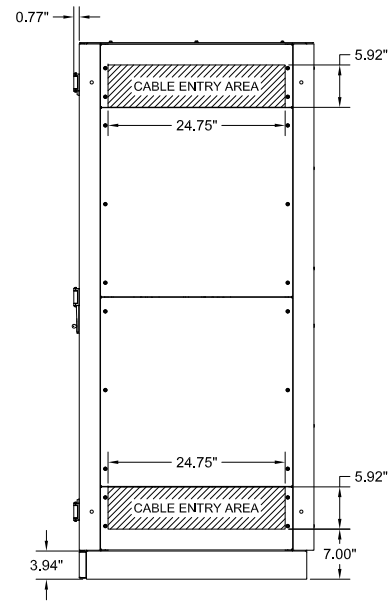

RIGHT SIDE VIEW

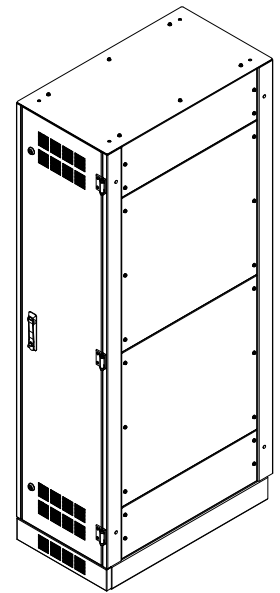

ISOMETRIC VIEW

NOTES:

1. APPROXIMATE WEIGHT: 325 LBS.
2. ASSEMBLY IS UL/CUL LISTED TO UL 891 AND C22.2 NO. 244.
3. NEMA 1 TYPE ENCLOSURE.
4. THE CABINET IS CONSTRUCTED FROM GALVANIZED STEEL.
5. THE CABINET IS TO BE MOUNTED THROUGH THE 0.750" HOLES IN THE CABINET LEGS. THE LEGS ARE FORMED FROM 10 GAUGE STEEL.
6. FINISH IS BLACK POWDER COAT ON ALL EXTERNAL AND VISIBLE SURFACES, INTERIOR PANELS AND MOUNT BRACKETS ARE GALVANIZED FINISH.
7. 200% RATED NEUTRAL BUS PROVIDED.
8. GROUND AND NEUTRAL LANDINGS ARE PROVIDED FOR ALL PANELBOARD CIRCUITS.
9. USE GE TYPE QB BREAKERS ON AQ SERIES PANEL.
10. USE GE TYPE TEY BREAKERS ON AE SERIES PANEL.
11. CABLES PROVIDED TO CONNECT INPUT POWER TO ADJACENT UPS MODULE OR MAINTENANCE BYPASS CABINET.

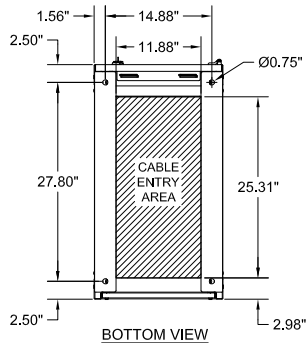

BOTTOM VIEW

PANELBOARD OPTIONS						
VOLTAGE	PANEL TYPE	AMPS	CIRCUITS	AIC	MAIN BREAKER	INPUT WIRE RANGE
208Y/120	AQ	225A	30	10K @ 208VAC	SFHA36AT0250	(1) 8 - 350 PER PHASE
			42			
480Y/277	AE		30	10K @ 480VAC		
			42			

<b>OUTPUT PANELBOARD DISTRIBUTION CABINET FOR TLE SERIES UPS</b> <b>480Y/277V OR 208Y/120V, 3Ø/4W/G, 225A PANELBOARD</b>								
--								
THE INFORMATION CONTAINED IN THIS DRAWING IS THE SOLE PROPERTY OF C&C POWER, INC. ANY REPRODUCTION WITHOUT THE WRITTEN CONSENT OF C&C POWER, INC IS PROHIBITED.								
DIMENSIONS ARE IN INCHES TOLERANCES: DECIMALS: .XX ±.13 .XXX ±.082	ANGLES: ±1°	<table border="1"> <tr> <th>INITIALS</th> <th>DATE</th> </tr> <tr> <td>DRAWN CH</td> <td>10/4/2017</td> </tr> <tr> <td>CHECKED CH</td> <td>10/4/2017</td> </tr> </table>	INITIALS	DATE	DRAWN CH	10/4/2017	CHECKED CH	10/4/2017
INITIALS	DATE							
DRAWN CH	10/4/2017							
CHECKED CH	10/4/2017							
SCALE: SEE A NTS: 1	SHEET 1 OF 1	 Manufactured by C&C Power for GE ©2017 C&C POWER, INC. ALL RIGHTS RESERVED						

DRAWING # 99852\_E-SD01-1 REV 1