

- NOTES:**
- EMPTY CABINET WEIGHT: 435 LBS
 - NEMA 1 ENCLOSED BATTERY CABINET.
 - FACTORY ASSEMBLED CABINETS ARE LISTED TO UL 1778.
 - WELDED STEEL CONSTRUCTION.
 - FINISH IS BLACK DURABLE CHIP & CORROSION RESISTANT POWDER COAT.
 - A MINIMUM REAR CLEARANCE OF 2" IS RECOMMENDED FOR OPTIMAL COOLING OF THE EQUIPMENT.
 - FOR EASE OF CONDUIT INSTALLATION, (1) 5" x 5" CONDUIT PLATE IS PROVIDED TO REPLACE A KNOCKOUT IN THE CABINET.
 - BATTERIES CAN BE ACCESSED FROM THE FRONT & REAR OF THE CABINET.
 - CABINET IS SUPPLIED ON SKID WITH HEAVY DUTY RAMP FOR EASY UNLOADING. CABINET IS TO BE MOVED USING THE CABINET CASTERS.
 - CENTER OF GRAVITY IS FIGURED WITH 400 WATT BATTERIES IN A 288V CONFIGURATION.
 - THE BC23S BATTERY CABINET (OPTIONAL CONFIGURATION) HAS BEEN CERTIFIED TO MEET THE 2012 EDITION OF THE INTERNATIONAL BUILDING CODE (IBC) AND THE 2013 EDITION OF THE CALIFORNIA BUILDING CODE (CBC) TO MEET DESIGN CATEGORY F, SS = 2.0 AND IMPORTANCE FACTOR 1.5.

BC23 BATTERY CABINET			
FOR USE W/ GE LP33 II SERIES 15 KVA UPS			
MECHANICAL DRAWING			
THE INFORMATION CONTAINED IN THIS DRAWING IS THE SOLE PROPERTY OF C&C POWER, INC. ANY REPRODUCTION WITHOUT THE WRITTEN CONSENT OF C&C POWER, INC IS PROHIBITED.			
DIMENSIONS ARE IN INCHES	TOLERANCES:	INITIALS	DATE
DECIMALS: .XX ±.13	ANGLES: .XXX ±.082	DRAWN JRL	03/11/2016
		CHECKED CH	03/11/2016
SCALE: NTS	SIZ: A	REV: 5	SHEET 1 OF 1
			© 2016 C&C POWER, INC. ALL RIGHTS RESERVED

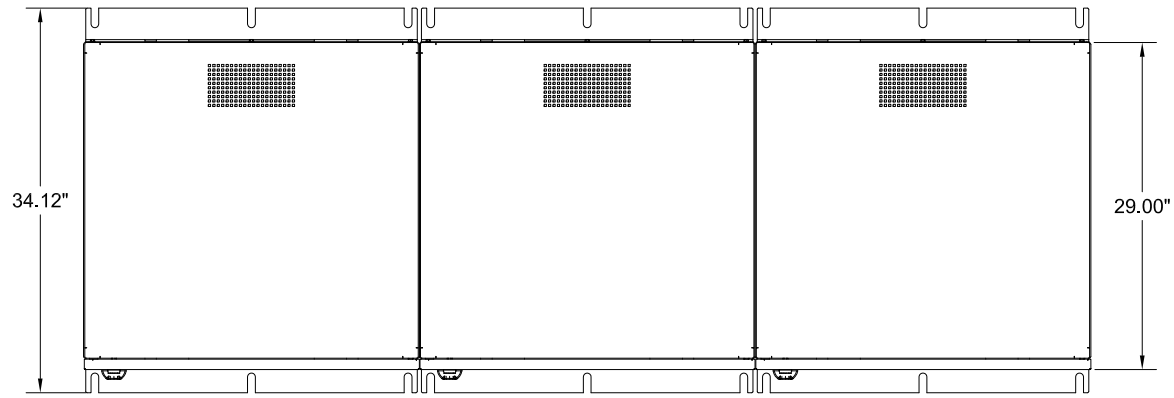

TOP VIEW

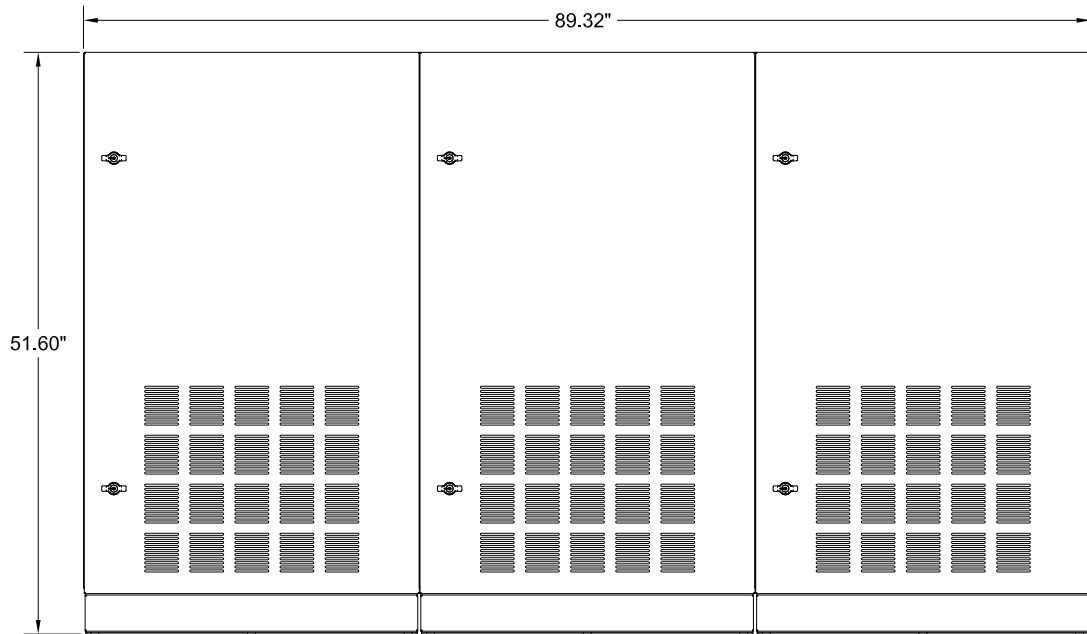

FRONT VIEW

BC23 (3) BATTERY CABINET SYSTEM			
FOR USE W/ GE LP33 II SERIES 15 KVA UPS			
MECHANICAL DRAWING			
THE INFORMATION CONTAINED IN THIS DRAWING IS THE SOLE PROPERTY OF C&C POWER, INC. ANY REPRODUCTION WITHOUT THE WRITTEN CONSENT OF C&C POWER, INC IS PROHIBITED.			
DIMENSIONS ARE IN INCHES		INITIALS	DATE
TOLERANCES:		DRAWN JRL	03/22/2016
DECIMALS: .XX ±.13	ANGLES: ±1°	CHECKED CH	03/22/2016
SCALE: NTS	SIZ: A	REV: 4	SHEET 1 OF 2



Manufactured by C&C Power for GE

© 2016 C&C POWER, INC. ALL RIGHTS RESERVED

DRAWING # 91423-SDF03-J REV 4

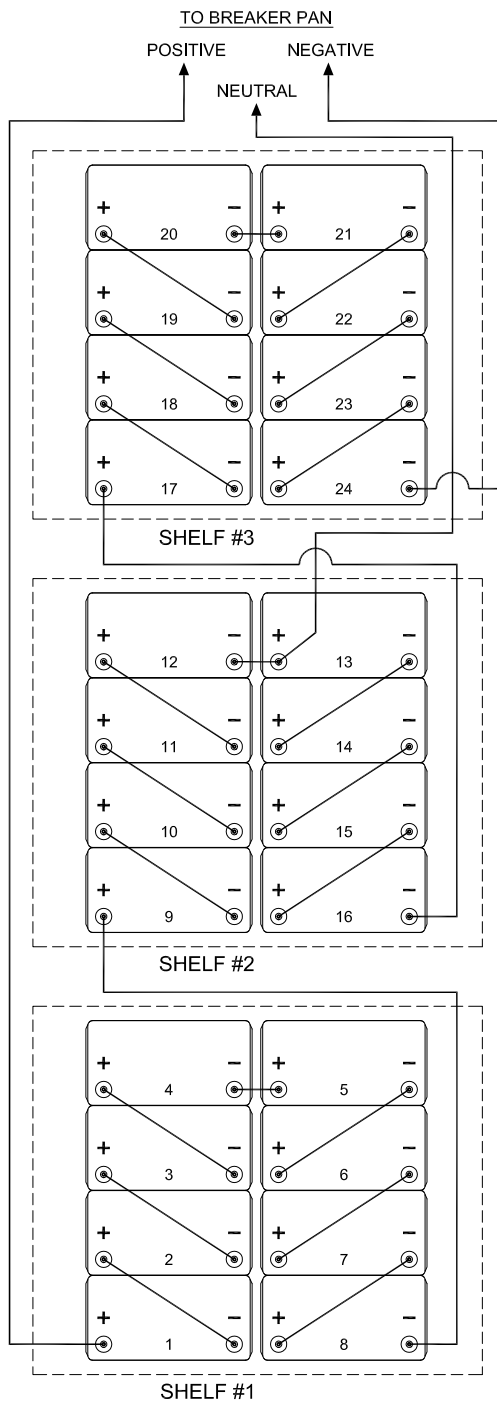

**288 (+144/-144) VDC WIRING
TYPICAL PER CABINET**

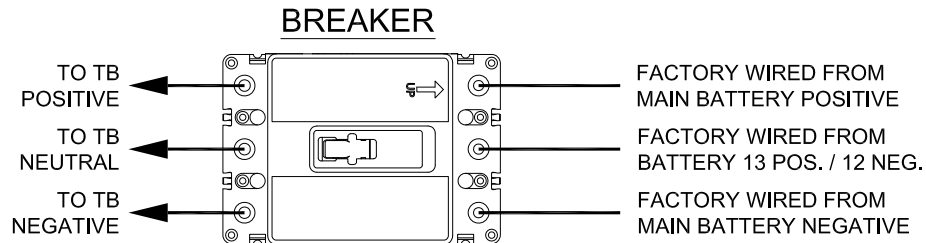

SPLIT BUS MULTI CAB PARALLELING TB WIRING

LOCATED IN CAB 1

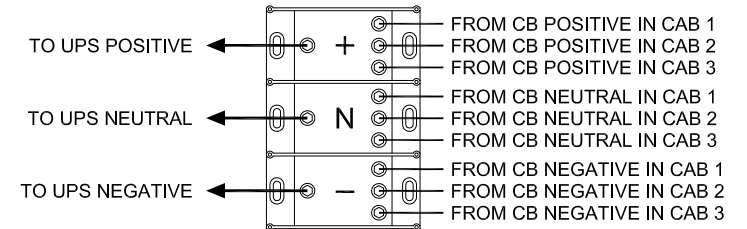

CHARGER*
LOCATED IN CAB 1

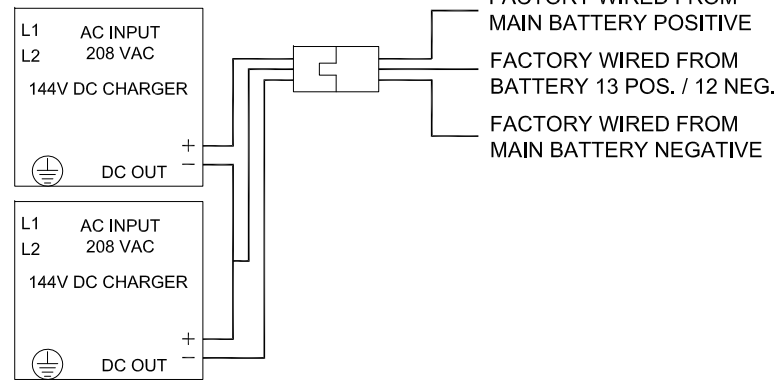

* CHARGERS ARE INCLUDED ON RUNTIMES > 1HR @ 100% LOAD

NOTES:

1. ALL INTERNAL WIRING IS UL LISTED, MTW, STYLE, 105C, EXTRA FLEXIBLE CABLE.
2. BREAKER IS UL LISTED.
3. BATTERY CABINETS WITH BREAKERS ARE SHIPPED WITH BREAKER IN THE OFF/OPEN POSITION.
4. MAIN CABLES FROM BATTERY CABINET TO UPS ARE INCLUDED AND ARE SIZED FOR A "SIDE BY SIDE" LINEUP WITH THE UPS.
5. INTER CABINET CABLES TO PARALLELING BLOCK IN CABINET 1 ARE INCLUDED AND ARE SIZED FOR A "SIDE BY SIDE" LINEUP.
6. CABINETS ARE SHIPPED WITH A BATTERY JUMPER REMOVED TO BREAK STRING VOLTAGE FOR ADDED SAFETY IN SHIPPING.
7. GROUND CONNECTION IS #6-300MCM MECHANICAL LUG.

BC23 (3) BATTERY CABINET SYSTEM			
FOR USE W/ GE LP33 II SERIES 15 KVA UPS			
ELECTRICAL DRAWING			
THE INFORMATION CONTAINED IN THIS DRAWING IS THE SOLE PROPERTY OF C&C POWER, INC. ANY REPRODUCTION WITHOUT THE WRITTEN CONSENT OF C&C POWER, INC IS PROHIBITED.			
DIMENSIONS ARE IN INCHES		INITIALS	DATE
TOLERANCES:	ANGLES:	DRAWN JRL	03/01/2016
DECIMALS: .XX ±.13	ANGLES: ±1°	CHECKED CH	03/01/2016
SCALE: NTS	SIZE: A	REV: 3	SHEET 2 OF 2



Manufactured by C&C Power for GE
© 2016 C&C POWER, INC. ALL RIGHTS RESERVED