

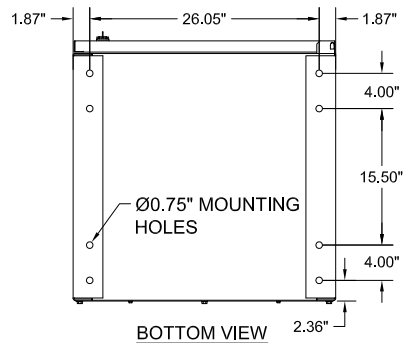

NOTES:

1. EMPTY CABINET WEIGHT: 425 LBS
2. FACTORY ASSEMBLED CABINETS ARE LISTED TO UL 1778.
3. HEAVY GAUGE WELDED STEEL CONSTRUCTION.
4. FINISH IS BLACK DURABLE CHIP & CORROSION RESISTANT POWDER COAT.
5. A MINIMUM REAR CLEARANCE OF 2" IS RECOMMENDED FOR OPTIMAL COOLING OF THE EQUIPMENT.
6. FOR EASE OF CONDUIT INSTALLATION, (1) 12.50" X 7.50" & (1) 6.25" X 5.125" CONDUIT PLATE IS PROVIDED TO REPLACE A KNOCKOUT IN THE CABINET.
7. BATTERIES CAN BE ACCESSED FROM THE FRONT AND REAR.
8. CABINET CAN BE MOVED WITH PALLET JACK OR FORK LIFT AT PALLET JACK ACCESS POINTS LOCATED AT FRONT OR REAR OF CABINET. FROM THE SIDES, THE CABINET CAN BE MOVED WITH ROL-A-LIFT TYPE EQUIPMENT MOVER. THE CABINET IS ONLY TO BE LIFTED FROM THE BOTTOM.
9. CENTER OF GRAVITY IS FIGURED WITH 540 WATT BATTERIES IN A 288V CONFIGURATION.
10. THE BC41S BATTERY CABINET (OPTIONAL CONFIGURATION) HAS BEEN CERTIFIED TO MEET THE 2012 EDITION OF THE INTERNATIONAL BUILDING CODE (IBC) AND THE 2013 EDITION OF THE CALIFORNIA BUILDING CODE (CBC) TO MEET DESIGN CATEGORY F, SS = 2.0 AND IMPORTANCE FACTOR 1.5.

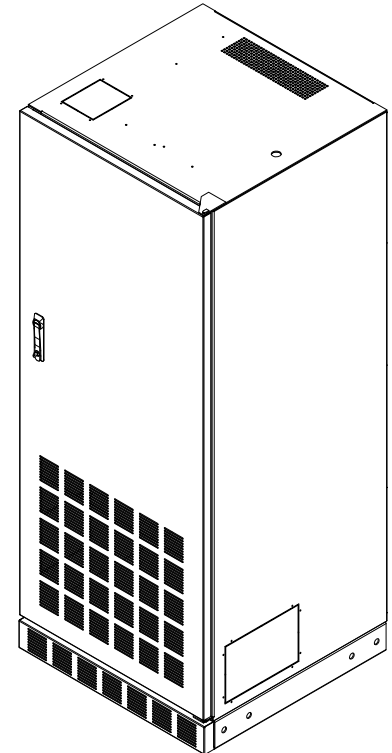
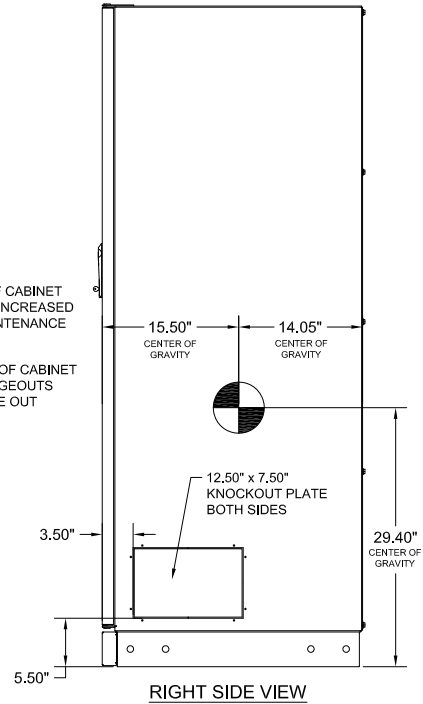
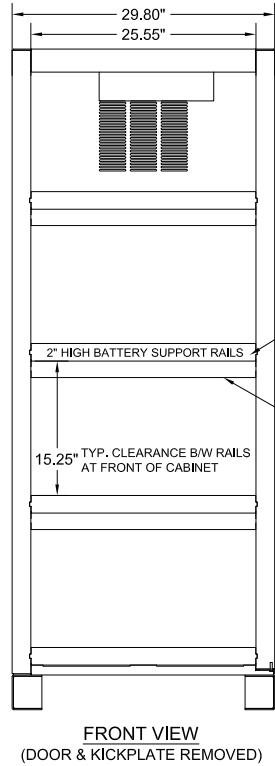
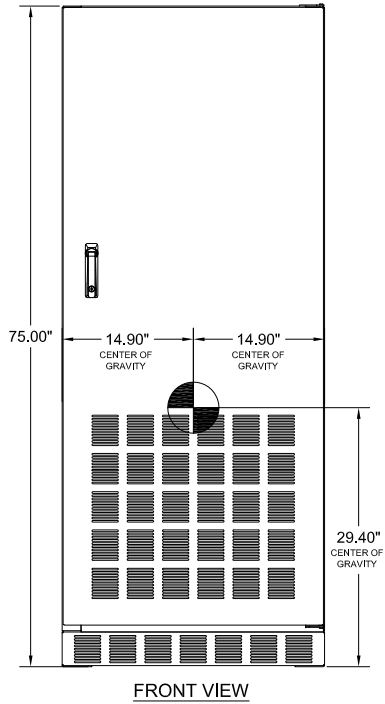

BC41 BATTERY CABINET			
FOR USE WITH GE LP33 II SERIES 20-100 KVA UPS			
MECHANICAL DRAWING			
THE INFORMATION CONTAINED IN THIS DRAWING IS THE SOLE PROPERTY OF C&C POWER, INC. ANY REPRODUCTION WITHOUT THE WRITTEN CONSENT OF C&C POWER, INC IS PROHIBITED.			
DIMENSIONS ARE IN INCHES		INITIALS	DATE
TOLERANCES:		DRAWN JRL	03/11/2016
DECIMALS: .XX ±.13	ANGLES: ±1°	CHECKED CH	03/11/2016
XXX ±.082			
SCALE: NTS	SIZ: A	REV: 4	SHEET 1 OF 1



Manufactured by C&C Power for GE

© 2016 C&C POWER, INC. ALL RIGHTS RESERVED

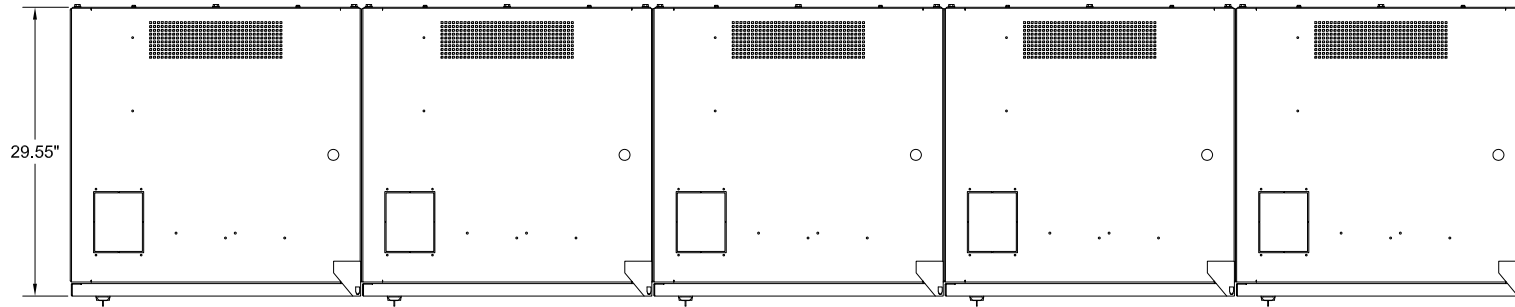

TOP VIEW

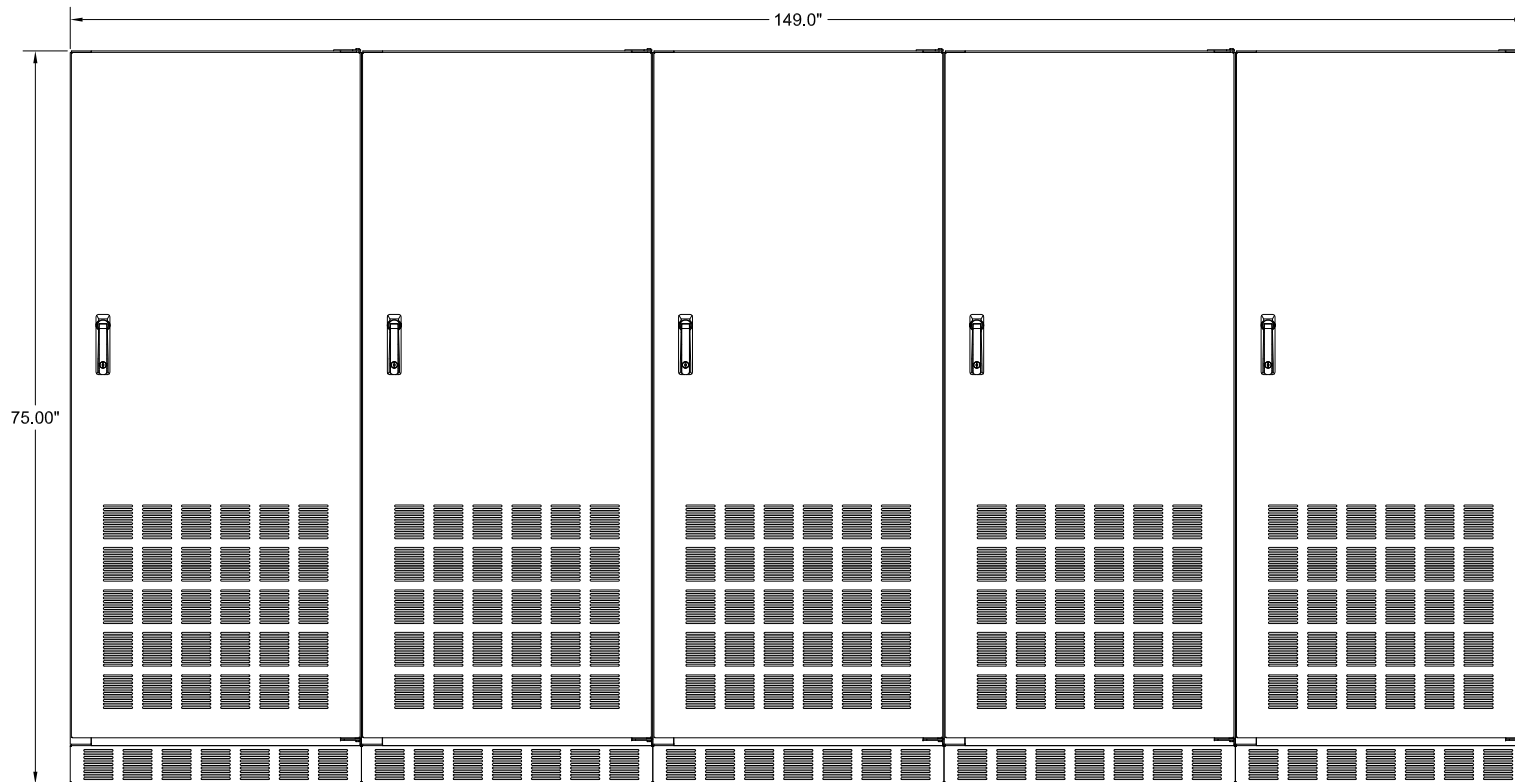

FRONT VIEW

BC41 (5) BATTERY CABINET SYSTEM FOR USE WITH GE LP33 II SERIES 20-100 KVA UPS			
MECHANICAL DRAWING			
<small>THE INFORMATION CONTAINED IN THIS DRAWING IS THE SOLE PROPERTY OF C&C POWER, INC. ANY REPRODUCTION WITHOUT THE WRITTEN CONSENT OF C&C POWER, INC IS PROHIBITED.</small>			
<small>DIMENSIONS ARE IN INCHES</small> <small>TOLERANCES:</small> <small>DECIMALS: .XX ±.13</small> <small>ANGLES: .XXX ±.082</small>	<small>INITIALS</small> <small>DRAWN JRL</small> <small>CHECKED CH</small>	<small>DATE</small> <small>03/23/2016</small> <small>03/23/2016</small>	 GE Critical Power <small>Manufactured by C&C Power for GE</small>
<small>SCALE: NTS</small> <small>SIZE: A</small> <small>REV: 2</small>	SHEET 1 OF 2		

DRAWING # 91441-SDF05-T REV 2

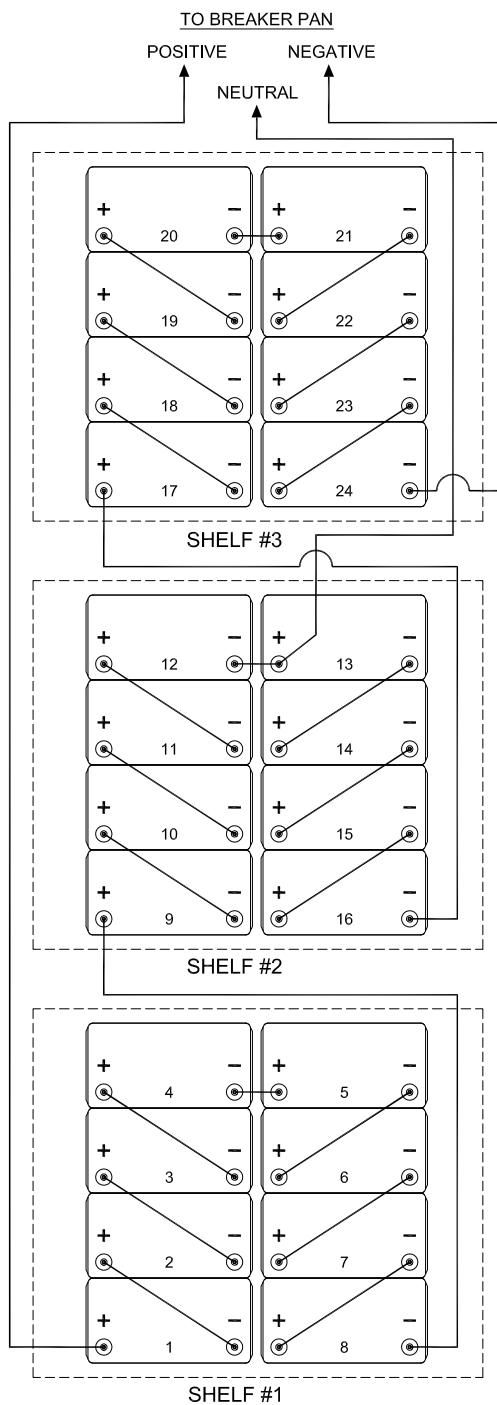

**288 (+144/-144) VDC WIRING
TYPICAL PER CABINET**

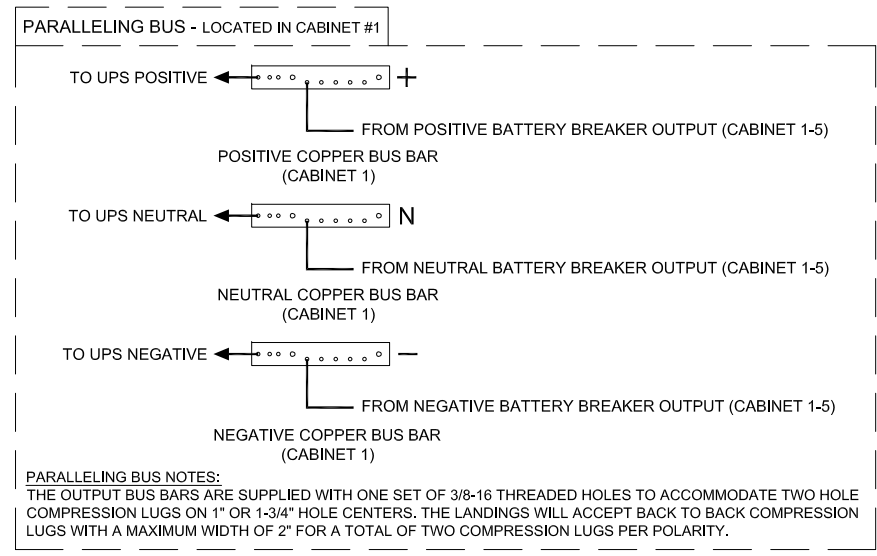

**CHARGER*
IN CABINET #1**

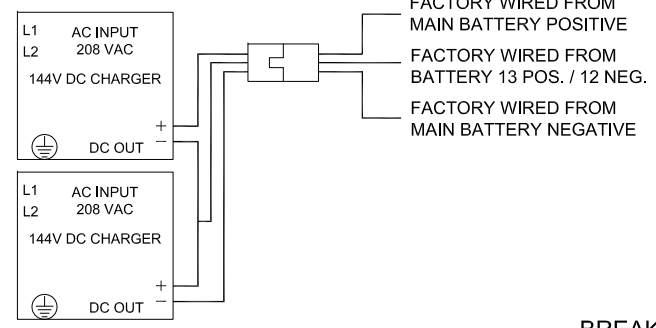

* CHARGERS ARE INCLUDED ON 20KVA MODELS WITH RUNTIMES > 1HR @ 100% LOAD

BREAKER PAN

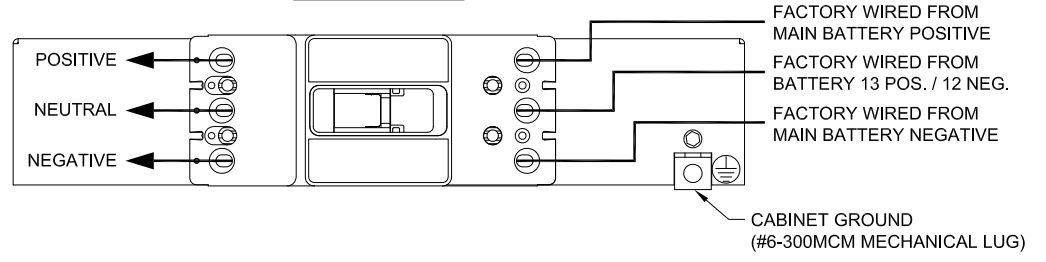

NOTES:

1. ALL INTERNAL WIRING IS UL LISTED, MTW, STYLE, 105C, EXTRA FLEXIBLE CABLE.
2. BREAKER IS UL LISTED.
3. BATTERY CABINETS WITH BREAKERS ARE SHIPPED WITH BREAKER IN THE OFF/OPEN POSITION.
4. MAIN CABLES FROM BATTERY CABINET TO UPS ARE INCLUDED AND ARE SIZED FOR A "SIDE BY SIDE" LINEUP WITH THE UPS.
5. INTER CABINET CABLES TO PARALLELING BUS IN CABINET 1 ARE INCLUDED AND ARE SIZED FOR A "SIDE BY SIDE" LINEUP.
6. CABINETS ARE SHIPPED WITH A BATTERY JUMPER REMOVED TO BREAK STRING VOLTAGE FOR ADDED SAFETY IN SHIPPING.
7. GROUND CONNECTION IS #6-300MCM MECHANICAL LUG.

BC41 (5) BATTERY CABINET SYSTEM			
FOR USE WITH GE LP33 II SERIES 20-100 KVA UPS			
ELECTRICAL DRAWING			
THE INFORMATION CONTAINED IN THIS DRAWING IS THE SOLE PROPERTY OF C&C POWER, INC. ANY REPRODUCTION WITHOUT THE WRITTEN CONSENT OF C&C POWER, INC IS PROHIBITED.			
DIMENSIONS ARE IN INCHES	INITIALS	DATE	
TOLERANCES:	DRAWN JRL	03/01/2016	
DECIMALS: .XX ±.13	CHECKED CH	03/01/2016	
ANGLES: .XXX ±.082			
SCALE: SEE A	REV: 1	SHEET 2 OF 2	
NTS		© 2016 C&C POWER, INC. ALL RIGHTS RESERVED	

DRAWING # 91441-SDF05-2 REV 1