



DESCRIPTIVE BULLETIN

AKD-20 and AKD-20 AR

Low voltage switchgear



Table of contents

04	The next chapter in the history of low voltage switchgear
05	Arc flash protection and selectivity
06–07	Advantages of AKD-20 low voltage switchgear
08	AKD-20 AR low voltage switchgear
09–10	AKD-20 The most powerful technology
11–12	AKD-20 Ratings and dimensions
13–16	AKD-20 AR Ratings and dimensions
17	Real-time information Real-people support

The next chapter in the history of low voltage switchgear

AKD-20 low voltage switchgear continues the tradition of the AKD switchgear line while delivering enhanced arc flash protection. Built to ANSI standards, its protection features include non-vented panels on the AR only, standard may have ventilation on rear doors or on auxiliary compartments. Bus insul/isol is optional on AKD-20, standard on AR, and it integrates the state-of-the-art EntelliGuard® breaker-trip unit system. It also features an optimized footprint that fits into a smaller area for the most common configurations.

EntelliGuard® G circuit breakers are low voltage circuit breakers, the next step in the evolution of a line known for exceptional reliability and performance. They are available from 800 A up to 6000 A on AKD-20, 5000 A on AR, with fault interruption ratings up to 150 kAIC – without fuses.

Integral to the EntelliGuard G line are the new, state-of-the-art EntelliGuard TU Trip Units, which provide superior system protection, system reliability, monitoring and communications. The breaker-trip unit system delivers superior circuit protection without compromising either selectivity or arc flash protection.

The EntelliGuard breaker-trip unit system demonstrates reliable electric power distribution, circuit protection and personnel protection.



1918	1960	1977	1980	1998	2005	2008	2014
First metal-clad switchgear	AKD-5 switchgear introduced	AKD-6 switchgear with AKR breakers	AKD-8 switchgear and MVT-9 trip unit	AKD-10 switchgear and Wavepro breakers	Entellisys® switchgear and EntelliGuard Breaker	AKD-20 switchgear and EntelliGuard G breaker	AKD-20 AR switchgear and EntelliGuard G breaker

Arc flash protection and selectivity

Now you don't have to choose

Modern economic reality and the regulatory environment demand system performance while recognizing the need to protect against the arc flash hazards that expose maintenance personnel to dangerous levels of heat, electrical energy, debris from damaged equipment and concussive forces.

The challenge is to provide both better personnel protection by minimizing arc flash hazards and maintain electrical power to mission-critical loads. But these objectives often seem to conflict, pitting the speed and sensitivity required to optimize safety against the sequence of operations and interlocking required to maximize power system availability.

The EntelliGuard G breaker-trip unit system meets the challenge. It achieves selectivity in a wide range of situations without excessive sacrifice of arc flash protection. With its Reduced Energy Let-through setting (RELT), the system protects at HRC1 or 2 for available fault currents as high as 100 kA. Here's how:

- Multiple short time bands under 100 ms optimally fit above the instantaneous clearing times of the EntelliGuard G circuit breaker
- Alternate Instantaneous setting (RELT) mitigates arc flash hazard while maintaining complete selectivity during normal operation, with an option for a positive feedback signal
- Special algorithm provides Instantaneous protection and simultaneously achieves selectivity – even when set low, it can provide 100,000A of selectivity
- Completely adjustable ST and GF Zone Selective Interlocking optimize restrained and unrestrained bands
- Zone Selective Instantaneous protection, multiple zone protection, 3 cycle clearing and selectivity are provided simultaneously
- Instantaneous trip adjusts up to 30X trip plug rating



Advantages of AKD-20 low voltage switchgear

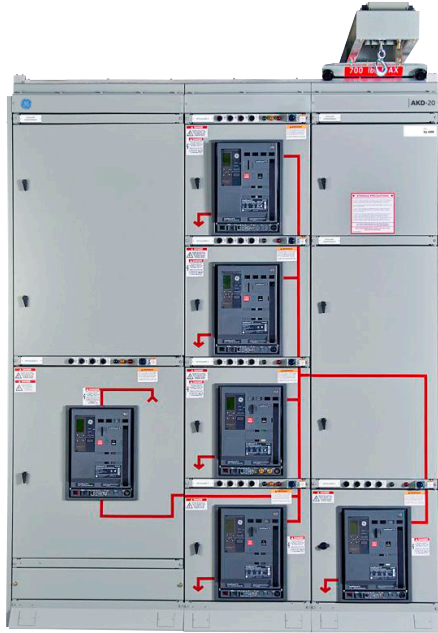

- A superior bus system offers different levels of protection
- Insulated and isolated bus makes maintenance procedures touch friendly to reduce the risk of arc flash
- True closed-door drawout construction is standard with all AKD-20 equipment. The breaker compartment doors remain stationary and closed while the breaker is racked out from the connect position, through test, to the disconnect position. Doors are secured with rugged 1/4-turn latches

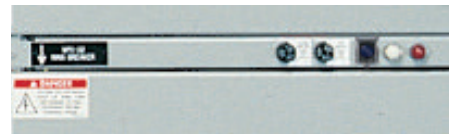

- An easy-to-read metal instrument panel above each circuit breaker holds a variety of control circuit devices, including the RELT switch

AKD-20 includes many features that address the needs of system reliability, arc flash protection and reduced footprint size.

- The optimized footprint uses smaller section sizes when possible. Sections are provided in 22", 34" available on AKD-20, not on AR
- Breaker compartment doors have no ventilation openings, thus protecting operators from hot ionized gases vented by the breaker during circuit interruption

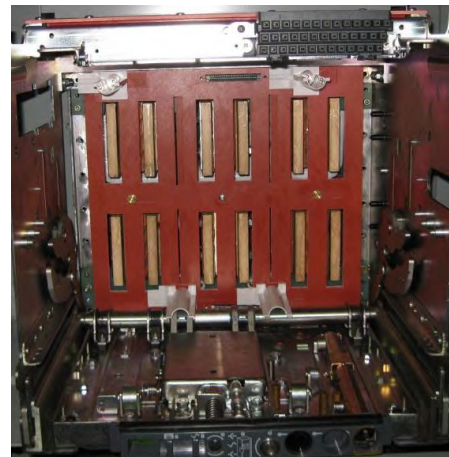
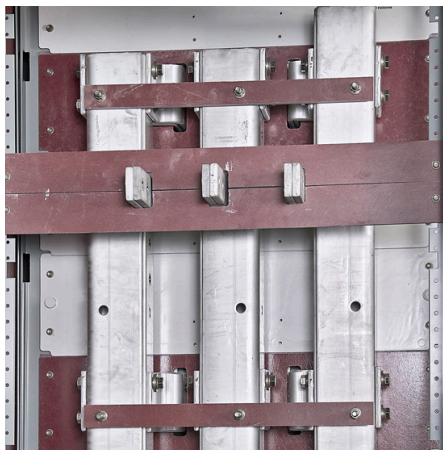

- Each circuit breaker is located in a completely enclosed ventilated compartment with grounded steel barriers to minimize the possibility of fault communication between compartments

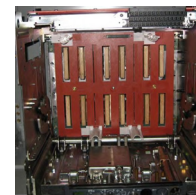

- Optional safety shutters protect operators from accidental contact with live conductors when the breaker is withdrawn
- Easy access to equipment compartments simplifies maintenance of the breaker cubicle and control circuit elements as well as inspection of the bolted bus connections
- The conduit entrance area meets NEC requirements. Extended depth frame options are available in 7" and 14" sizes for applications requiring additional cable space. The section width also can be increased for additional cable space
- A rail-mounted hoist on top of the switchgear provides the means for installing and removing breakers from the equipment. This is a standard feature on NEMA 3R outdoor walk-in construction and optional on indoor construction



- Optional infrared (IR) scanning windows can be installed in the switchgear rear covers to facilitate the use of IR cameras for thermally scanning cable terminations
- AKD-20 switchgear can be expanded easily to handle increased loading and system changes. Specify a requirement for a fully equipped future breaker to obtain a cubicle that has been set up for additional breaker installation, or add vertical sections without modifications or the use of transition sections



- Control wires run between compartments in steel riser channels. Customer terminal blocks are located in metal-enclosed wire troughs in the rear cable area. Intercubicle wiring is run in a wireway on top of the switchgear, where interconnection terminal blocks are located
- All EntelliGuard G circuit breakers are equipped with rollers and a guidebar to provide easy and accurate drawout operation
- An optional remote racking device reduces the risk of the arc flash hazard by allowing the operator or electrician to move the breaker anywhere between the DISCONNECT and CONNECT positions from outside the arc flash boundary

- An array of safety interlock and padlocking features are available to accommodate any type of lockout-tagout procedure a customer may have.
- on the breaker to keep it open and trip free
 - on the breaker in the TEST or DISCONNECT position
 - on the breaker to prevent racking when the breaker contacts are closed
 - on the cubicle door latch to prevent unauthorized entry into the breaker compartment
 - on the cubicles to prevent unauthorized installation of a breaker that has been removed from the cubicle for equipment or load maintenance
 - mechanical interlocking of two breakers, in various configurations, to prevent procedural errors

AKD-20 AR

Arc resistant low voltage switchgear

AKD-20 AR : Protection you can count on
ABB's AKD-20 Arc Resistant (AR) Switchgear solutions are for applications where an extra margin of safety is essential. They meet the IEEE C37.20.7 Type 2B AR standard which states that the equipment will provide arc resistance protection on the front, rear, and sides while opening designated low voltage compartments.

Think ahead: Redirect arc flash explosions
AKD-20 AR is designed to contain and redirect the arc flash energy and exhaust gases up through the plenum at the top of the enclosure and away from the operator. In the case of an arc flash event, pressure activated flaps slam shut to seal ventilation areas in the rear cable compartment.

The rugged dead front panels protect personnel from the explosive force of arc flash occurrences. The circuit breaker cubicle doors are provided with a reinforced escutcheon gasket, protecting operators from exhaust gases and other materials.

Designed for the safety of personnel and equipment

The AKD-20 AR is designed with the safety of your personnel and equipment in mind. The smaller footprint allows for flexibility in your plans.

AR features:

- Internal exhaust chimney
- Heavy-duty enclosure
- Same footprint as standard AKD-20 and Entellisys
- Insulated/isolated bus
- Bus compartment barriers
- Section barriers and shutters
- Push-to-latch circuit breaker cubicle doors
- Pressure activated rear vent flaps
- Reinforced circuit breaker escutcheon gasket
- Plenum flange
- Full height hinged and bolted rear doors
- Floor plates in cable compartment

AKD-20

The most powerful technology

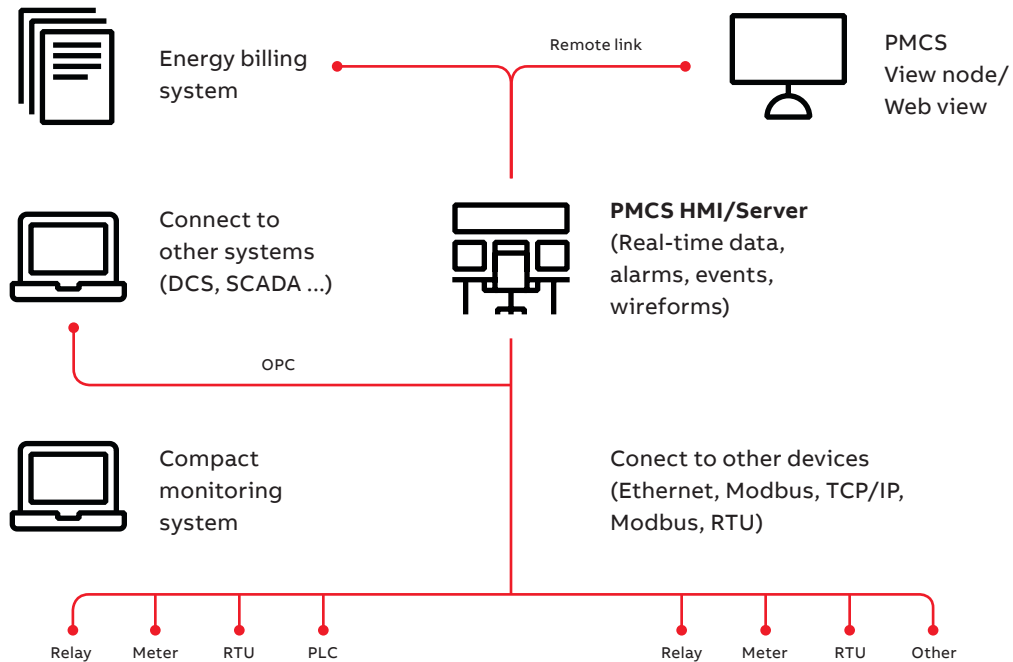

The best in power management

A large amount of information flows inside through every switchgear lineup in the form of power (volts, amps, waveforms) passing through. With the proper devices and meter and trip unit Power Management Control System (PMCS), you can selectively access this wealth of information. PMCS is the easy-to-use software package that turns a desktop computer into a virtual window for tracking and controlling facility power. It can help you increase productivity, decrease downtime, improve predictive maintenance, increase facility safety and diagnose power quality problems.

With just a few clicks of a mouse, you can gain real-time access to the family of meter and trip units devices and most third-party devices or systems. With PMCS's powerful analytical tools, you can perform advanced power quality analysis, monitor energy consumption, and even manage loads. These features are all available through sophisticated graphics and a highly intuitive interface. PMCS is both ModBus RTU® and Modbus TCP/IP Ethernet compatible. They all add up to the most flexible, open-architecture, high-performance power management system available today.

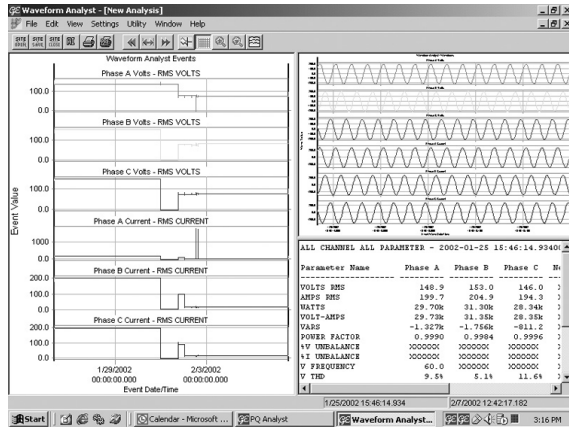

Demand Tab		Sliding Window Demand	
	Instantaneous	Maximum	
Positive kWh	-749069.22	4394376.05	
Con. VAR for Max. +ve kWh	N/A	1812953.19	
Negative kWh	N/A	-2347249.55	
Con. VAR for Max. -ve kWh	N/A	-37240310.42	
Group Name	ES13324	1064447.84	2003091.25
Meter Name	0107 Nexus 1200	N/A	-37257096.10
Root Ver. No.	0.0.2.9	13015919.49	4887070.15
RunTime Ver. No.	0.17.0		
DSP Boot Ver. No.	0.0.0.4		
DSP RunTime Ver. No.	0.14.4		
Serial No.	1680		
On Time	1680		
On Time	Apr 25, 2002 13:04:17.99		
Current Time	Apr 25, 2002 13:17:32.34		

MinMax		Phase A		Phase B		Phase C		
Ph. Voltage/Min/Max	Ph. Cur./Amps/Min/Max	THD Cur./%	THD Vol./%	Ph. Voltage/Min/Max	Ph. Cur./Amps/Min/Max	THD Cur./%	THD Vol./%	
PH 1487.30	A 2.89	1.00	0.00	0.39	PH 1487.37	B 2.99	1.00	0.00
PH 1487.37	A 2.99	1.00	0.00	0.39	PH 1487.30	B 2.89	1.00	0.00
PH 1487.30	A 2.89	1.00	0.00	0.39	PH 1487.37	B 2.99	1.00	0.00
PH 1487.37	A 2.89	1.00	0.00	0.39	PH 1487.30	B 2.89	1.00	0.00



The best in metering and power quality

The latest high technology EPM devices – the EPM 6000 and 9000 series – are available for the AKD-20. They boast broad capabilities for usage monitoring, cost allocation, load monitoring, demand tracking, common couplings with utilities, load and process control, and power quality monitoring.

These EPMs cover the moderate range of the metering spectrum, providing solutions for panel mount and submetering applications (EPM 6000), and the high end of the power quality spectrum (EPM 9450Q and 9650Q). The Power Quality Meter System, PQM II, is also available for applications requiring a feature set between the EPM 6000 and EPM 9000 offerings.

AKD-20

Ratings and dimensions

AKD-20 indoor low voltage switchgear height is 92" with available breaker stacking space of 84". Optional 78" high indoor equipment, with a breaker stacking space of 70", is available. The breaker frame size and type determine both the width of the breaker sections and the minimum depth of the switchgear line-up. The deepest device in the line-up determines the depth of the entire line-up.

Envelope size	Breaker type	Continuous amps	Instantaneous interrupting rating (kA)			Short-time ratings (kA)	Close & latch rating (kA)	Switchgear dimensions		
			240V	480V	600V			Minimum width	Minimum depth	Optional depth
1	S	400	65	65	50	50	22"	67" or 74"		
	N		65	65	65	65				
	P		100	100	65	65				
	N	800	65	65	65	65				
	S		65	65	50	50				
	P		100	100	65	65				
	N	1600	65	65	65	65				
	P		100	100	65	65				
	N		2000	65	65	65				65
	P	100		100	65	65				
E	800	85		85	85	85				
M		100	100	85	85					
E		1600	85	85	85	85				
M	100		100	85	85					
E	2000		85	85	85	85				
M		100	100	85	85					
N		3200	65	65	65	65				
E	85		85	85	85					
M	100		100	85	85					
3	M	3200	100	100	100	100	34"	54"		
	L		150	150	100	100				
	M		100	100	100	100				
	L	4000	150	150	100	100				
	M		100	100	100	85				
	L		5000	100	100	100				100
M	100	100		100	85					
L	6000	150		150	100	100				
						38"	67"	74"		

Sample AKD-20 layout

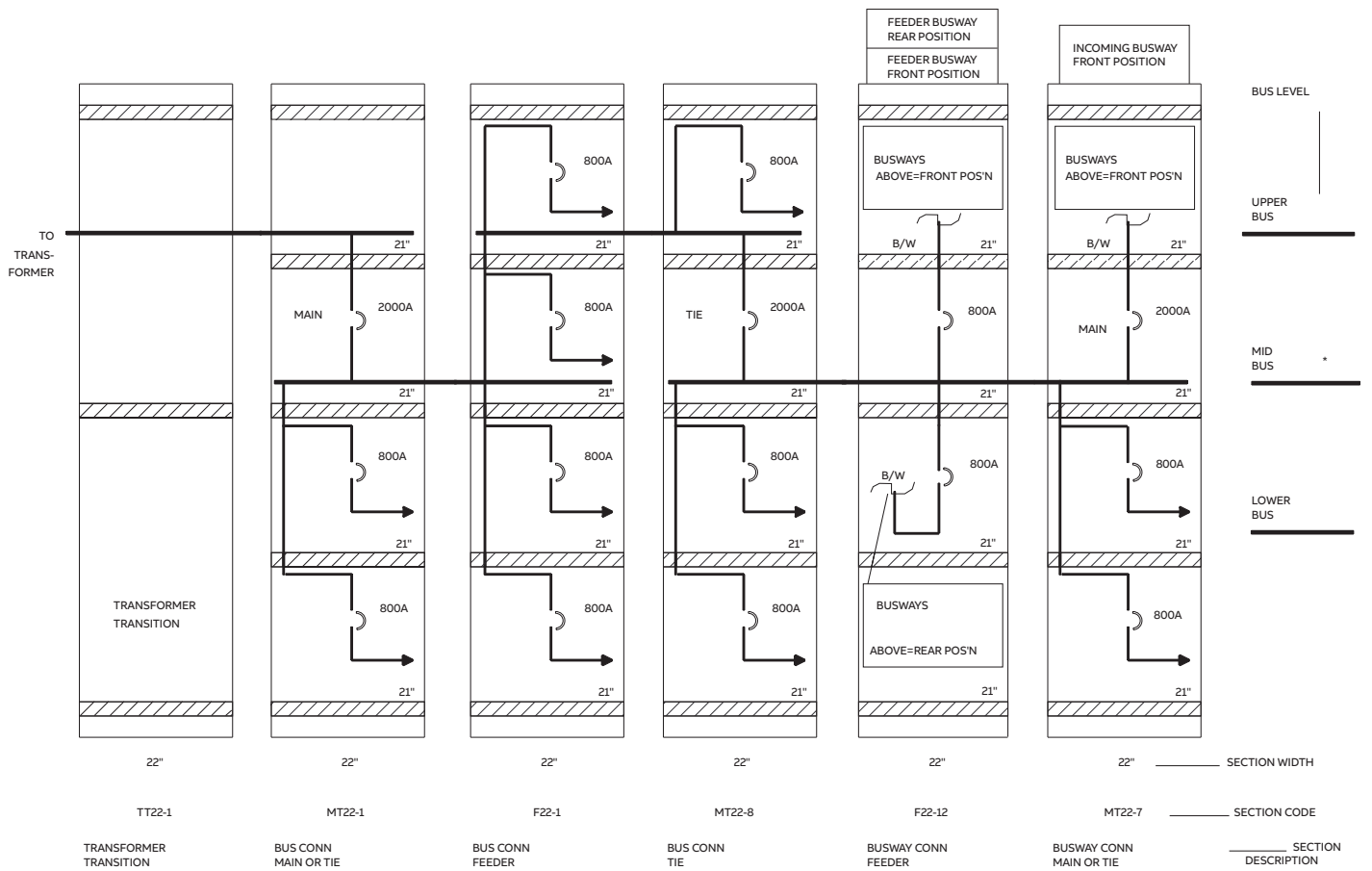
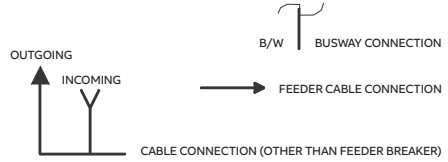

AKD-20 AR

Ratings and dimensions

Standards and approvals

- IEEE C37.20.7 – Type 2B
- ANSI C37.20.1
- UL 1558, UL1066

Ratings

- System Voltage Nominal (Max):
480 (508)-600 (635) Volts
- Main Bus: 800-5000 Amp
- Enclosure Type: Indoor NEMA 1, 54 inch deep frame
- Internal Arc Current: 65kA
(85kA - consult factory)
- (RMS) at 0.5 sec

Other options

- Rear extensions to 60, 67, 74 inch deep frame
- Infrared scanning window in rear doors
- Lockable T-handles on circuit breaker cubicle door
- Lockable T-handles on rear doors

Guideform specifications

AKD-20 Arc Resistant switchgear is provided in NEMA 1 indoor construction for electrical systems rated up to 5000 A, 600 volts, 65kA. AKD-20 Resistant switchgear meets the requirements of the following IEEE and UL standards:

- IEEE C37.20.1 (2002) Metal-Enclosed Low Voltage Power Circuit Breaker Switchgear
- IEEE C37.20.7 (2007) Guide for Testing Metal-Enclosed
- Switchgear for Internal Arcing Faults (tested to Type 2B requirements)
- UL1558 Metal-Enclosed Low Voltage Power Circuit Breaker Switchgear

AKD-20 Arc Resistant switchgear is provided with a plenum flange on the top of each vertical section (refer to conduit/floorplan detail below).

The plenum flange mates with the owner-supplied plenum. ABB will provide the following relative to the plenum:

1. Details on the minimum material thickness for the plenum
2. Details on the minimum cross section of the plenum (minimum ceiling height – 10FT)
3. Details on the mating plenum flange on the top of each vertical section
4. Exhaust port with rodent screen and hinged flap for use on the exiting end of the plenum

Cubicles with provisions for future circuit breakers are provided with a cover plate in the circuit breaker door cutout and a cassette barrier behind the door. All circuit breaker cubicle doors are provided with a “push-to-latch” mechanism, which eliminates the need for any additional motions to secure the circuit breaker door – a critical factor in maintaining the Type 2B Arc Resistant rating of the equipment.

Conduit space – Envelope 1 and 2 circuit breakers – Main/Tie/Feeder
Available in 22 in and 30 in widths (30in wide section with 3.5in conduits shown)

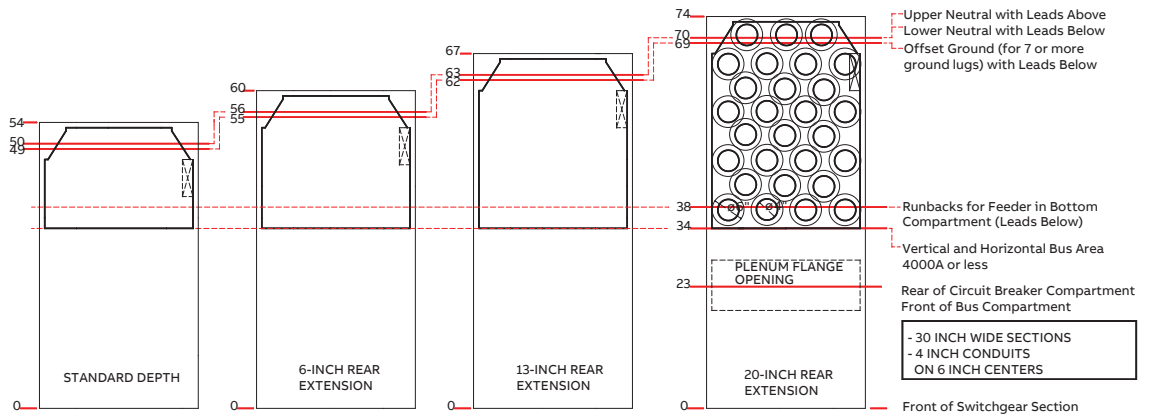
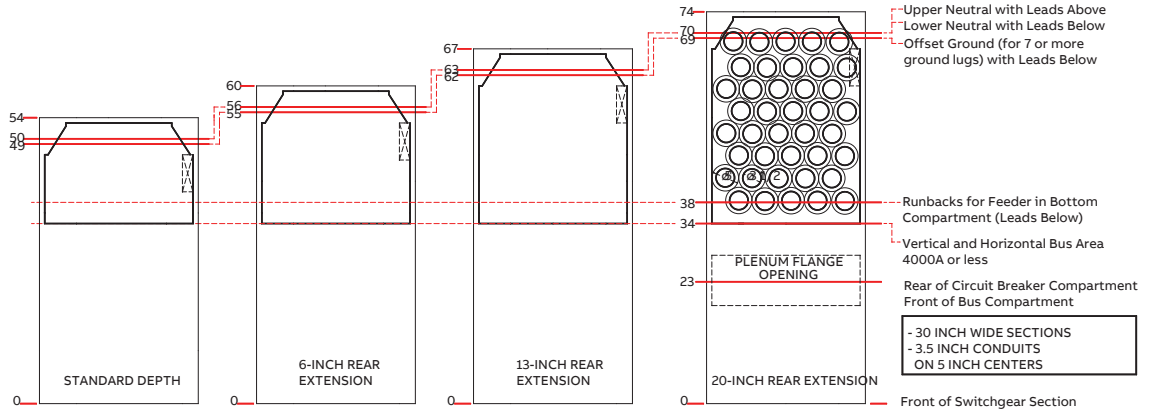

Example elevation drawings – please consult factory for additional configurations

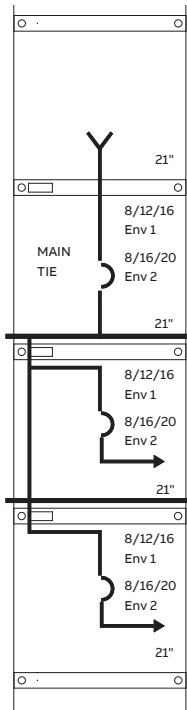

22 / 30"

MT22-2

CABLE CONN
MAIN OR TIE

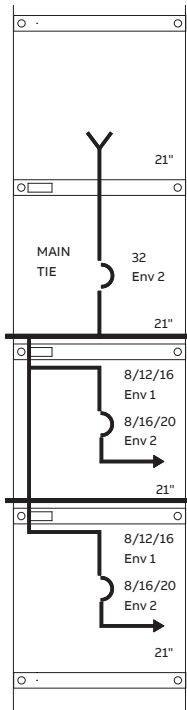

30"

MT22-2A

CABLE CONN
MAIN OR TIE

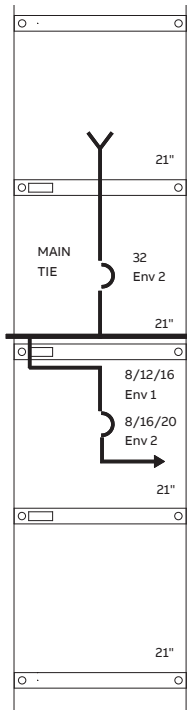

30"

MT22-2B

CABLE CONN
MAIN OR TIE

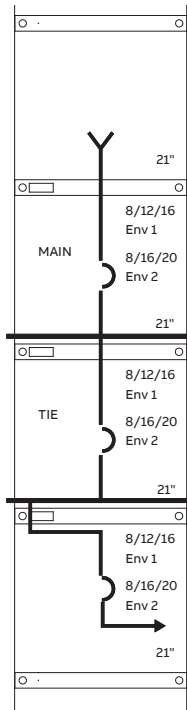

22 / 30"

MT22-3

CABLE CONN
MAIN

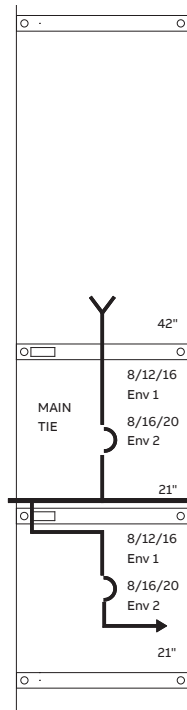

22 / 30"

MT22-4

CABLE CONN
MAIN OR TIE

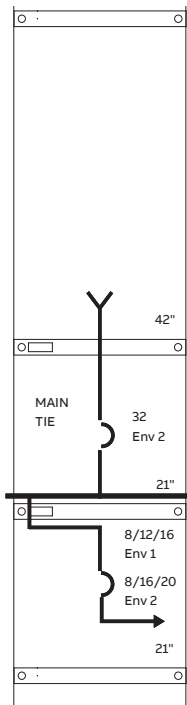

30"

MT22-4A

CABLE CONN
MAIN OR TIE

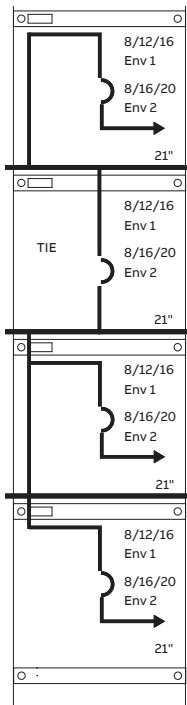

22 / 30"

MT22-8

BUS CONN
TIE

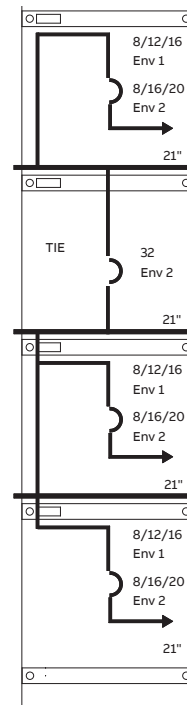

22 / 30"

MT22-8A

BUS CONN
TIE

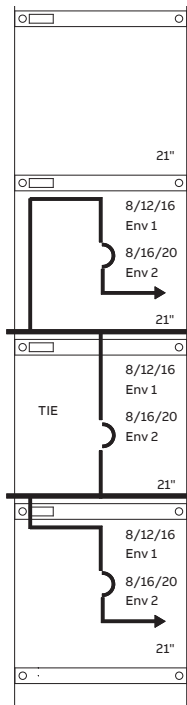

22 / 30"

MT22-9

BUS CONN
TIE

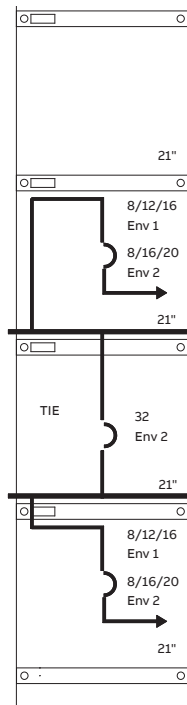

22 / 30"

MT22-9A

BUS CONN
TIE

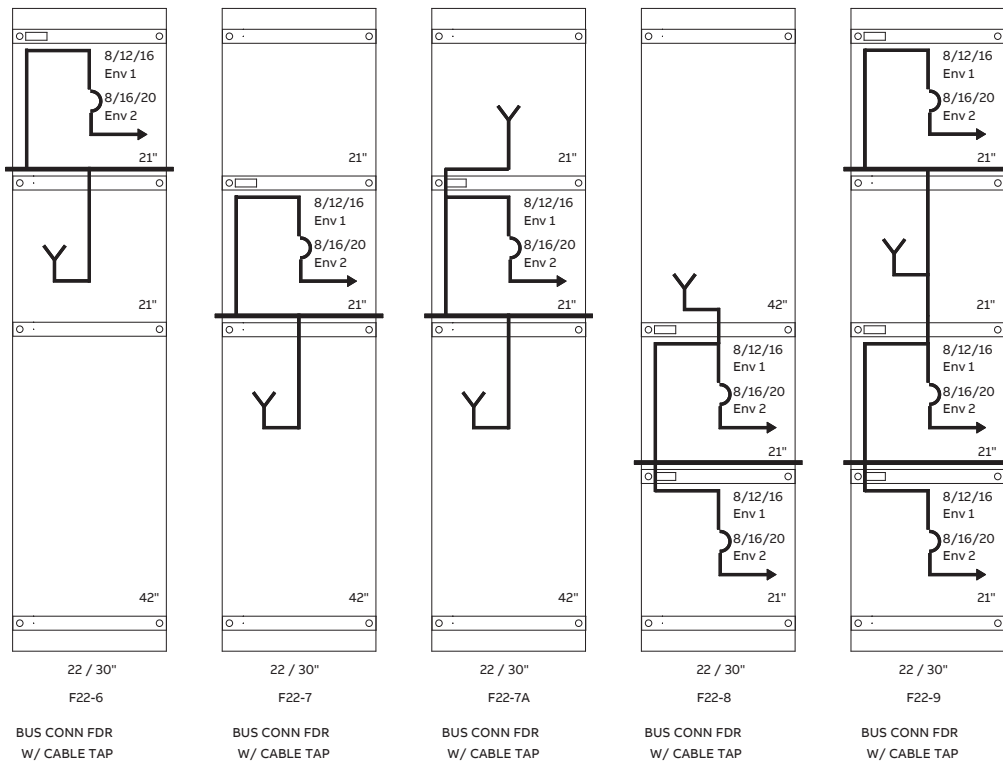
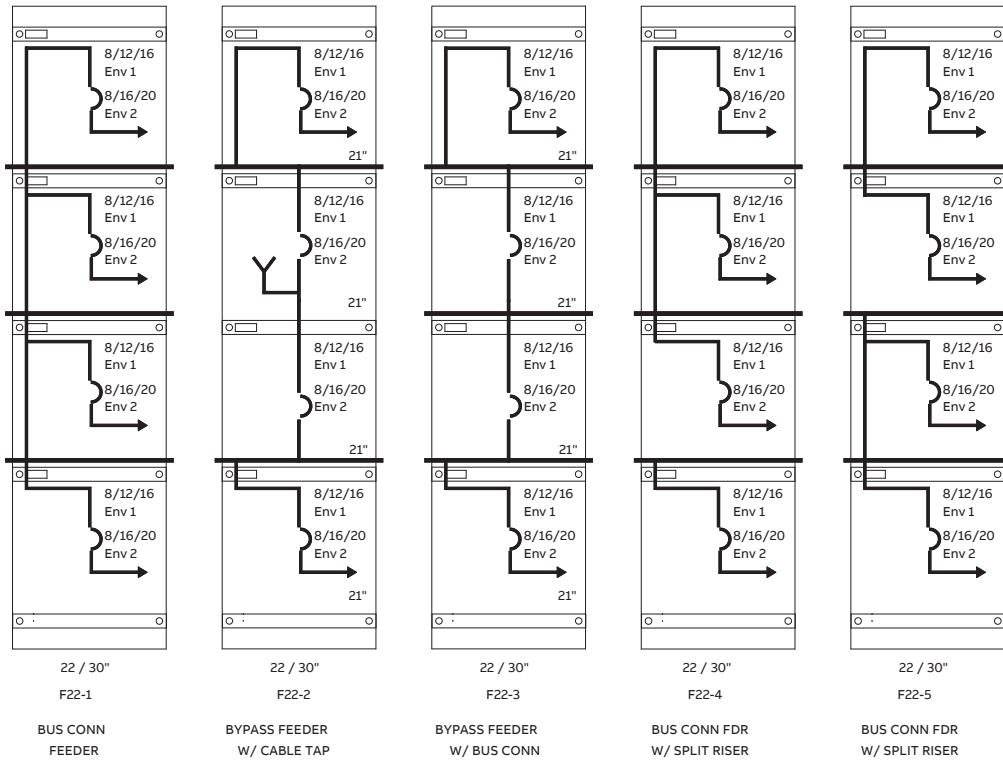

Real-time information

Real-people support

Whether it's on the web, on your own computer or on the phone, getting transactional answers, product information and technical support from ABB is easy and sure.

<https://electrification.us.abb.com/products/switchgear>

All of the technical documentation you need is available on our web site. The Publication Library delivers application guides, installation and maintenance instructions, brochures, layouts, dimensions and time current curves.

ABB Smart catalogs™

<https://electrification.us.abb.com/buylog>

Our BuyLog® Catalog provides comprehensive data on all the products available from the Electrical Distribution business. Detailed ratings, catalog numbers, dimensions and weights, list prices and more. They automatically download updates as they become available.

Order management the way you like it

Speedi, our leading configuration, estimating and ordering tool is available to identify the correct catalog number and price to ensure you receive the product you need.

Post sales support

Call 1-888-437-3765 for in warranty service, genuine spare parts and ABB field support services.

1,400 distributor locations

When local contact is the answer, ABB's authorized distributors meet your needs. With more than 500 different firms in over 1,400 locations, there's a local distributor near you, and specialist distributors address the needs of your target market segment.

Find your nearest distributor easily at

<https://electrification.us.abb.com/your-business/distributor>

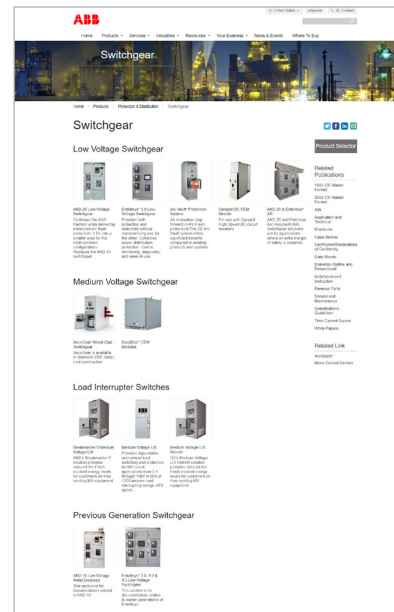

—
ABB Inc.

305 Gregson Drive
Cary, NC 27511
USA

abb.com/lowvoltage

**GE is a trademark of GE.
Manufactured by ABB Ltd
under license from General
Electric Company.**

The information contained in this document is for general information purposes only. While ABB strives to keep the information up to date and correct, it makes no representations or warranties of any kind, express or implied, about the completeness, accuracy, reliability, suitability or availability with respect to the information, products, services, or related graphics contained in the document for any purpose. Any reliance placed on such information is therefore strictly at your own risk. ABB reserves the right to discontinue any product or service at any time.

© Copyright 2020 ABB. All rights reserved.