

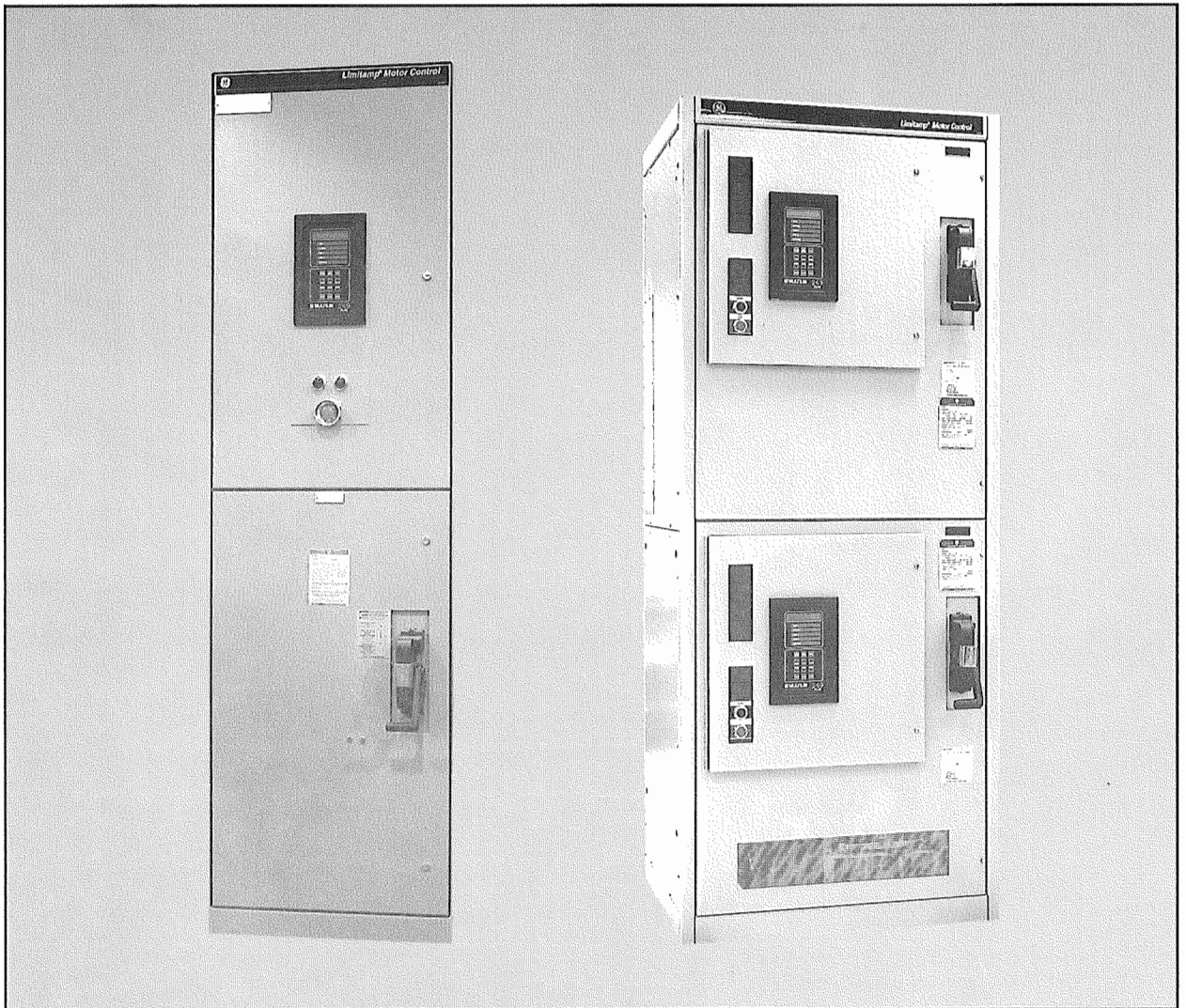

DEF-002

Vacuum Limitamp® Medium Voltage Motor Control



CR194 Renewal Parts Bulletin



Table of Contents

Introduction1
Reference Publications1
Parts Identification1
High-Voltage Contactor Nameplate1
Limitamp Panel Data Nameplate2
Catalog Numbering Systems2
CR194 Replacement Parts4
 One-high diagram4
 One-high parts list5
 Two-high parts list6
 Two-high photographs
 Two-high with upper low-voltage door open8
 Two-high with both high-voltage doors open9
 High-voltage section - drawout contactor10
 High-voltage drawout contactor components11
 High-voltage section - stationary contactor12
 High-voltage stationary contactor components13
 Main/vertical bus - rear view14
 Typical motor terminal area15
Handle assembly16
One-high ground bus parts17
One-high horizontal bus assembly parts17
Two-high ground bus parts17
Two-high horizontal and vertical bus assembly parts17
Upper and lower fuse support assembly parts17

Warning: Before any adjustments, servicing, parts replacement or any other act is performed requiring physical contact with the electrical working components or wiring of this equipment, all power must be removed and locked off from all sources and all attached rotating equipment must have come to a complete stop. User personnel must be completely familiar with the following operating and maintenance instructions before attempting to service this equipment.



Introduction

The CR194 Vacuum Limitamp® Controller, a quality GE product, was designed and manufactured to give long and satisfactory service. This bulletin contains items that, through normal use, may require periodic replacement; other items may never need service or replacement during the useful life of the equipment.

Reference Publications

- GEH-5305 — Instructions for One-High Controllers
- GEH-6263 — Instructions for Two-High Controllers
- GEH-6840 — Application and Selection Guide
- GEH-5306 — CR193 Vacuum Contactor Instructions
- GEF-8016 — Renewal Parts for CR193B and D Contactor

For additional assistance, please refer to factory.

Parts Identification

This bulletin will provide the information necessary to identify, by description or actual catalog number, replacement parts for CR194 Vacuum Limitamp® Motor Controllers.

The following pages will describe where important equipment identification numbers can be found and provide catalog numbers for assemblies and individual parts that may require periodic replacement through normal wear.

Table 1.
CR194 Publication Abbreviations

AC	Alternating Current	Instr.	Instruction
Asm.	Assembly	LH	Left Hand
Cont.	Contacteur	LV	Low Voltage
CPT	Control Power Transformer	MB	Main Bus
CT	Current Transformer	NP	Nameplate
GFCT	Ground Fault Current Transformer	PT	Potential Transformer
Horz.	Horizontal	RH	Right Hand
HV	High Voltage	Supt.	Support
Inc.	Incoming	VB	Vertical Bus
		QMQB	Quick-Make Quick-Break

Should a situation arise in which a part cannot be identified, the factory should be contacted. In order for the factory to provide assistance in identifying the part, the Catalog Number and Diagram Number of the equipment must be known (see Limitamp Panel Data Nameplate).

High-Voltage Contactor Nameplate

High-voltage contactor renewal parts are found in separate renewal parts publications depending on the contactor catalog number. This catalog number is found on the contactor nameplate mounted on the top of the contactor. An example of this nameplate is shown below:



Figure 1. High-Voltage Contactor Nameplate

The proper bulletin can be selected from the table below:

Table 2.
CR194 High-Voltage Contactor Renewal Parts Publications

CR194 Vacuum	
Contacteur Catalog Number	Renewal Parts Publication
CR193B	GEF-8016
CR193D	GEF-8016

Limitamp Panel Data Nameplate

This nameplate is mounted near the starter handle operator on the high-voltage door. It contains all the necessary information for the factory to positively identify the starter and its bill of material. This information must accompany all part orders and quotation requests. Below is an example of the nameplate:

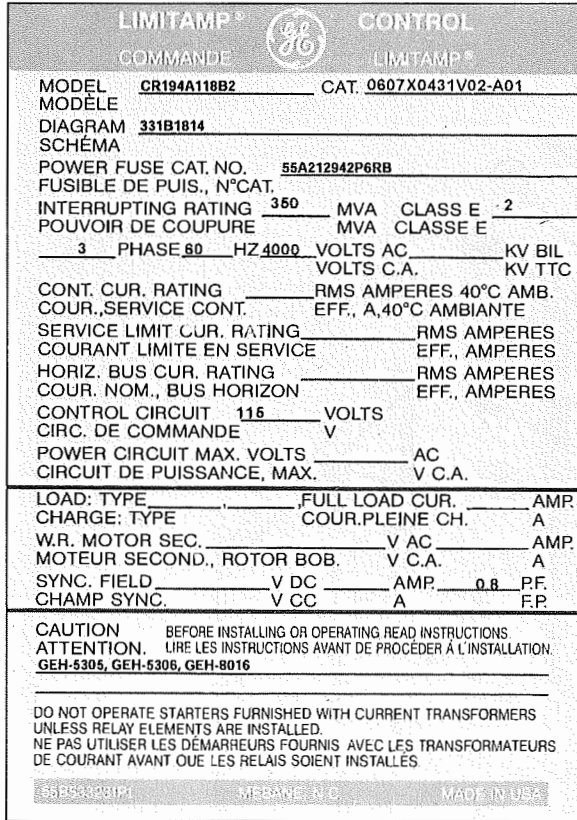

Figure 2. Limitamp Panel Data Nameplate

The required information is the catalog number and the diagram number. The catalog number from the sample above is 0607X0431V02-A01. The number can be broken down as follows: 0607X0431 is the material list number or shop order number for the job, V02 is the overall lineup designation, and A01 is a section in that lineup. The diagram number identifies the group of drawings that pertain to this particular project order.

Sections that do not have a panel data nameplate will have a compartment nameplate mounted on the right side door flange. An example is shown below:

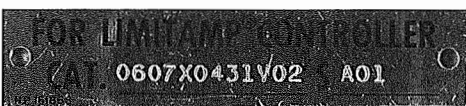

Figure 3. Limitamp Compartment Nameplate

This will provide the catalog number only. The diagram number can be obtained from any Panel Data Nameplate on the lineup.

Catalog Numbering System

Vacuum Limitamp control is manufactured in two construction types: one-high and two-high. One-high construction consists of one medium-voltage contactor in one 90-inch-high enclosure. Two-high construction contains two medium-voltage contactors in one 90-inch-high enclosure.

You should first determine the construction type (one-high or two-high) of your equipment. After determination, the following pages should be consulted:

- ▲ Pages 4 and 5 for one-high construction
- ▲ Pages 6 -15 for two-high construction

Caution should be observed in that a part number in one-high construction may have a different description and catalog number than the same part number in two-high construction.

CR Number Designation

CR194 Vacuum Limitamp Motor Control equipment identification numbers are determined as follows:

CR194

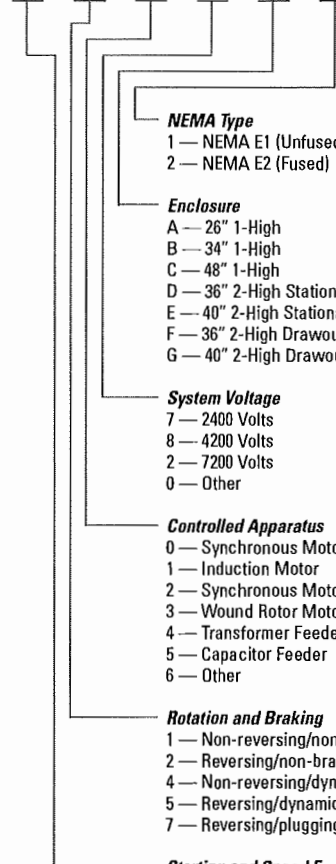

- NEMA Type**
 - 1 — NEMA E1 (Unfused)
 - 2 — NEMA E2 (Fused)
- Enclosure**
 - A — 26" 1-High
 - B — 34" 1-High
 - C — 48" 1-High
 - D — 36" 2-High Stationary
 - E — 40" 2-High Stationary
 - F — 36" 2-High Drawout
 - G — 40" 2-High Drawout
- System Voltage**
 - 7 — 2400 Volts
 - 8 — 4200 Volts
 - 2 — 7200 Volts
 - 0 — Other
- Controlled Apparatus**
 - 0 — Synchronous Motor (brushless type)
 - 1 — Induction Motor
 - 2 — Synchronous Motor (ring type)
 - 3 — Wound Rotor Motor
 - 4 — Transformer Feeder
 - 5 — Capacitor Feeder
 - 6 — Other
- Rotation and Braking**
 - 1 — Non-reversing/non-braking
 - 2 — Reversing/non-braking
 - 4 — Non-reversing/dynamic braking
 - 5 — Reversing/dynamic braking
 - 7 — Reversing/plugging
- Starting and Speed Functions**
 - A — Single-speed, full voltage
 - B — Single-speed, reduced voltage reactor type
 - C — Single-speed, reduced voltage, autotransformer type
 - D — Single-speed, part winding start
 - E — Single-speed, reduced voltage primary resistor
 - G — 2-speed, 1 winding full voltage
 - H — 2-speed, 1 winding reactor reduced voltage
 - J — 2-speed, 1 winding autotransformer reduced voltage
 - N — 2-speed, 2 winding full voltage
 - P — 2-speed, 2 winding reactor reduced voltage
 - Q — 2-speed, 2 winding autotransformer reduced voltage



One-High

Figure 4: CR194 One-high

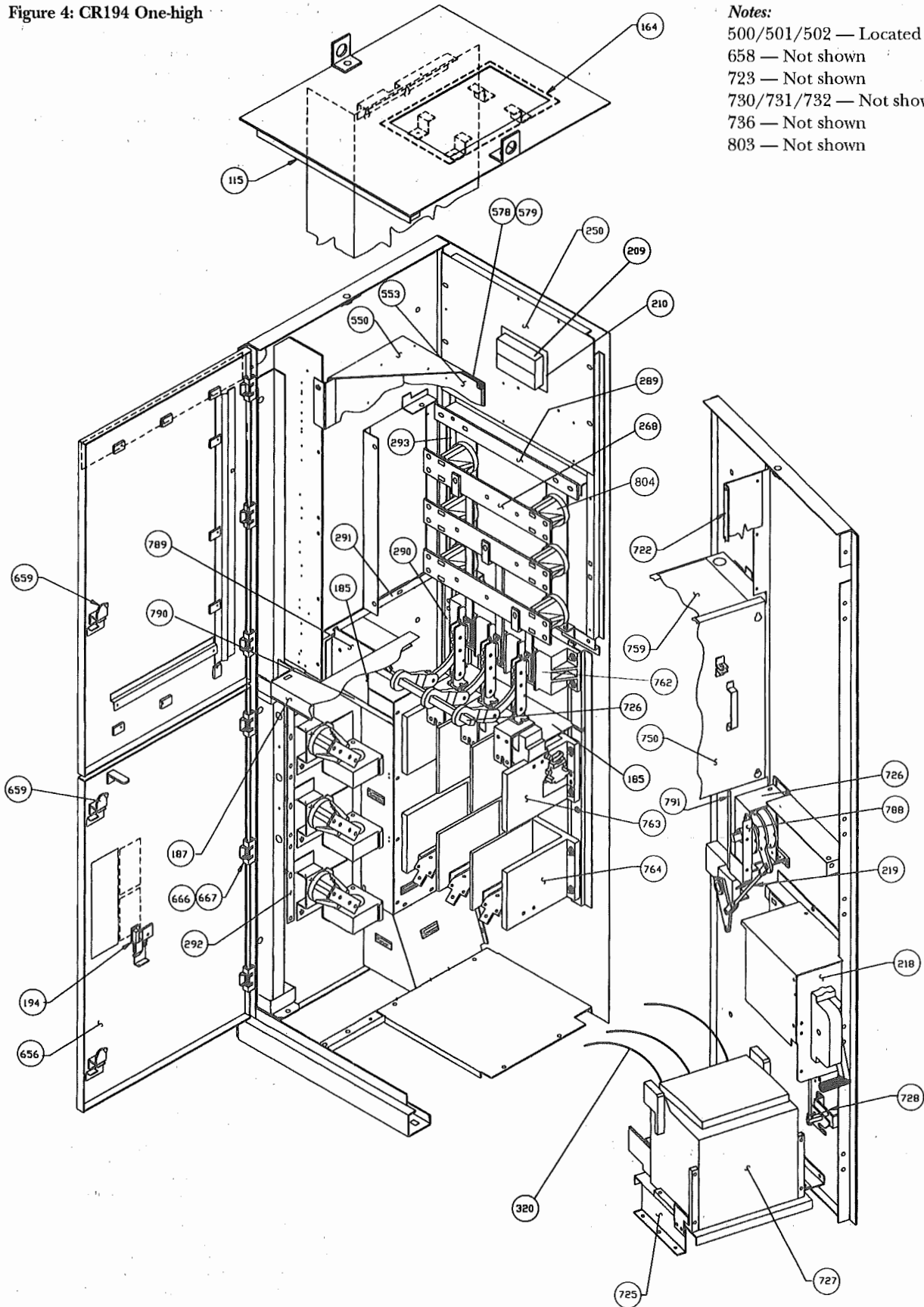

Notes:

- 500/501/502 — Located on LV base
- 658 — Not shown
- 723 — Not shown
- 730/731/732 — Not shown
- 736 — Not shown
- 803 — Not shown

Table 3.
CR194 One-High Vacuum, 26" and 34" Wide Parts List (see Figure 4)

Material List Item Number	Part Description	Part Number 26" Wide	Part Number 34" Wide	Qty.
115	Wire Trough	55B533095G1	68J222210CB0000AAB	1
164	Dust Shield NEMA 1	68J122214VN0000AAB	68J122207DF0000AAB	1
185	Switch Front Barrier (viewing)	68J122210GD0000AAN	68J122210GD0000AAN	1
187	Compartment Barrier	55A212940G3	55A212940G4	1
194	Door Interlock Defeater	194A6916G1	194A6916G1	1
209	CPT Fuse Block	55C682289G3	55C682289G3	1
210	CPT Fuse Block Insulation	55B534922P1	55B534922P1	1
218	Handle Asm.	302A3749G* ①	302A3749G* ①	1
219	Handle to QMQB Rod	55B533263G1	55B533263G1	1
250	CPT Mounting Base	68J222209TU0000AAB	68J210552AB34XXXXB	1
268	Horiz. MB	②	②	3
289	Ground Bus	③	③	1
290	Lower Rear Vertical Ground Bus	68J122210FP0000BB* ④	68J122210FP0000BB* ④	1
291	Side/Horiz. Ground Bus	68J122210FQ0000BB* ④	68J122210FQ0000BB* ④	1
292	Front Bottom Vertical Ground Bus	68J122210FR0000BB* ④	68J122210FR0000BB* ④	1
293	Upper Rear Ground Bus	68J122210FN0000BB* ④	68J122210FN0000BB* ④	1
320	Fuse Base to Cont. Strap	55B533388P1	55B533388P1	3
500	Test Switch (10A)	CR104PSG21B92	CR104PSG21B92	1
500	Test Switch (20A)	328A1141P1	328A1141P1	1
501	Switch NP (10A)	328A1140P1	328A1140P1	1
501	Switch NP (20A)	Included with item 500 (20A)	Included with item 500 (20A)	
502	Test Switch Mounting Bracket	68J122214NS0000AAB	68J122214NS0000AAB	1
550	Swingout Panel	68J222210DB0000AAB	68J222222SM0000AAB	1
553	LV Base	68J1222210BX0000AAB	68J120132BT0504AAB	1
578	Swingout Barrier	68J122220DT0000AAB	68J122220DT0000AAB	1
579	Swingout Supt. Barrier	68J122220DS0000AAB	68J122220DS0000AAB	1
656	HV Door NEMA 1	68J210551ALXXXXXB	68J210551ANXXXXXB	1
656	HV Door NEMA 12	68J210551AKXXXXXB	68J210551AMXXXXXB	1
658	Door Vent Barrier	68J122210FG0000AAN	68J122210FG0000AAN	2
659	Door Latch Asm.	104B9336G2	104B9336G2	3
666	Door Hinge Pin	1459941P1	1459941P1	6
667	Door Hinge	147A4728G1	147A4728G1	6
722	Swing Base Stop Barrier	68J120125DL0000AAB	68J120125DL0000AAB	1
723	Wire Harness	V26G3	V34G3	1
725	Cont. Base	55B533255G1	55B533255G1	1
726	QMQB Operator	55C682220G1	55C682220G2	1
727	Vacuum Cont.	⑤	⑤	1
728	Mechanical Interlock Cont. to Handle	55B533039G1	55B533039G1	1
730	Wire Comb Cleat	171B4725P1	171B4725P1	AR
731	Wire Comb Cover	171B4726P1	171B4726P1	AR
732	Wire Comb Supt.	219A1242P1	219A1242P1	1
736	Swingout Handle	104B9322P18	104B9322P6	1
750	Front AC Bus Barrier	Contact Factory	Contact Factory	1
759	Top Main Bus Cover	Contact Factory	Contact Factory	1
762	Vertical Bus Asm.	55C682205G13	55C682205G13	1
763	Switch & Upper Fuse Supt.	55D781301G* ⑥	55D781301G* ⑥	1
764	Lower Fuse Supt.	55B533212G* ⑥	55B533212G* ⑥	1
788	Front Barrier Side Supt.	55B533258G1	55B533258G1	1
789	Front Switch Barrier	55B533264G1	55B533264G2	1
790	Lower Switch Barrier w/ Inc Line	55B533267G1	55B533267G2	1
790	Lower Switch Barrier w/o Inc Line	55B533267G3	55B533267G4	1
790	Lower Switch Barrier w/o Inc Line 7.2KV	55B533267G5	55B533267G5	1
791	QMQB Rear Switch Barrier	68J122210HD0000AAB	68J122210HD0000AAB	1
803	Power Fuse	see Panel Data NP for fuse part number	see Panel Data NP for fuse part number	3
804	MB Insulator	157C8185P1	157C8185P1	1

AR As Required

① See Tables 5 and 6

② See Table 8

③ See Table 7

④ Add suffix (*) per plating finish:

N=no plating, TC=Silver, TB=Tin.

⑤ See contactor nameplate and GEF-8016.

⑥ See Table 11



Two-High

Table 4.
CR194 Two-High Vacuum, 36" and 40" Wide Parts List (see Figures 5-12)

Material List Item Number	Part Description	Figure Number	Part Number 36" Wide	Part Number 40" Wide	Qty.
127	Cont. Pin Bracket	①	55B533223G2	55B533223G2	1
128	Cont. Socket Bracket	①	55B533224G2	55B533224G2	1
129	Interlock Wire Harness	①	VCP2	VCP2	1
153	Lower Rear Cover	NS	68J110508DGXXXXXB	68J110508DNXXXXXB	1
154	Upper Rear Cover	NS	68J110508DCXXXXXB	68J110508DMXXXXXB	1
155	Lower Side Cover	5	68J110508DDXXXXXB	68J110508DDXXXXXB	2
156	Right Side Upper Cover	5	68J110508DHXXXXXB	68J110508DHXXXXXB	1
157	Vented Top Cover	NS	68J210552DBXXXXXB	68J210552DLXXXXXB	1
157	Non-Vented Top Cover	NS	68J110508DAXXXXXXB	68J110508DKXXXXXB	1
158	Left Side Upper Cover	5	68J110508DJXXXXXB	68J110508DJXXXXXB	1
161	Upper Side MB Cover	NS	55B528977P1	-	2
161	Upper Side MB Cover	NS	-	55B528977P2	1
162	Upper Side MB Cover	NS	-	55B528977P1	1
164	Vented Top Drip Cover	NS	55C685906P1	55C685906P1	1
170	Center Front Wire Trough	NS	55C685909P1	55C685909P2	1
174	Top Control Cover Plate	NS	55B528965P1	55B528965P2	1
180	Side Bus Barrier	11	55B528966P1	55B528966P1	2
194	HV Door Defeater	6	55B534903G1	55B534903G1	1
209	CPT Fuse Block	8/9/10	55C682289G2	55C682289G2	1
210	CPT Fuse Block Insulation	8/9/10	55B534922P1	55B534922P1	1
218	Handle Asm.	6/7/9	55D781326G1 ②	55D781326G1 ②	1
219	Cont. & Handle Mechanical Interlock	7/9	55C685924G1	55C685924G1	1
250	CPT Fuse Block Plate (2KVA)	9/10	55B528973G1	55B528973G1	1
250	CPT Fuse Block Plate (3KVA)	8/9/10	55B528973G2	55B528973G2	1
268	Horiz. MB	11	③	③	1
277	MB Insulator	NS	157C8185P1	157C8185P1	AR
289	Horiz. Ground Bus	11	④	④	1
296	Side Ground Bus Asm.	12	55B534904G* ⑤	55B534904G* ⑤	1
299	Upper VB Brace	11	55C685929G1	55C685929G1	1
308	Window CT Plate Asm.	12	55C685926G3	55C685926G2	1
310	Cont. Slide Plate	NS	55B528941G1	55B528941G1	2
320	Fuse Base to Cont. Strap, Drawout	8	55B534940P1	55B534940P1	3
320	Fuse Base to Cont. Strap, Stationary	NS	55B553388P1	55B553388P1	3
363	HV Door Latch	5	N722DP21022B6	N722DP21022B6	2
500	Test Switch 10A	5	CR104PSG21B92	CR104PSG21B92	1
500	Test Switch 20A	5	328A1141P1	328A1141P1	1
501	Test Switch NP 10A	5	328A1140P1	328A1140P1	1
501	Test Switch NP 20A	5	Included with item 500 (20A)	Included with item 500 (20A)	-
502	Test Switch Mounting Bracket 10A	5	68J122214NS0000AAB	68J122214NS0000AAB	1
550	LV Box	6/8	55C682296G1	55C682296G1	1
553	LV Device Plate	5	68J122223DE0000AA9MM	68J122223DE0000AA9MM	1
560	TB Plate Insulation	12	55B528979P1	55B528979P2	1
568	Upper TB Plate	12	55B528984G2	55B528984G4	1
568	Lower TB Plate	12	55B528984G1	55B528984G3	1
632	LV Door Latch	5	117B5064G3	117B5064G3	2
650	Push Button Device Plate	5	169C6350KFP4	169C6350KFP4	2
651	Push Button Device Plug	5	272A5650UWG1	272A5650UWG1	4
652	Push Button Device Supt.	NS	204B4050TTP1	204B4050TTP1	2
656	Upper HV Door	5	68J210551CQXXXXXB	68J210551CWXXXXXB	1
656	Vented Lower HV Door	5	68J210551CNXXXXXB	68J210551CUXXXXXB	1
656	Non-Vented Lower HV Door	5	68J210551CPXXXXXB	68J210551CVXXXXXB	1
658	HV Door Hinge Asm.	12	55B534937G1	55B534937G1	3
659	LV Door Bracket	5	55C685916G1	55C685916G1	1
703	Right Side Bus Barrier	NS	55B528992P1	55B528992P1	1
705	Left Side Bus Barrier	NS	55B528989P1	55B528989P1	1
706	Left MB Side Barrier	NS	-	55C682254P2	1
707	Upper Rear Cover Insulation	NS	55C682278P1	55C682278P2	1
708	Top Wire Trough	NS	55B534918P1	55B534918P2	1
709	Center VB Insulation	11	55C682252P1	55C682252P1	1

Table 4.
CR194 Two-High Vacuum, 36" and 40" Wide Parts List (see Figures 5-12)

Material List Item Number	Part Description	Figure Number	Part Number 36" Wide	Part Number 40" Wide	Qty.
710	Compartment Barrier Window	NS	55C685908P1	55C685908P1	1
711	Side Bar-Lower Compartment	NS	55C685903P1	-	2
711	Side Bar-Lower Compartment	NS	-	55C685903P1	1
711	Side Bar-Lower Compartment	NS	-	55C685903P2	1
712	MB Side Barrier	NS	55C682254P1	-	2
712	MB Side Barrier	NS	-	55C682254P1	1
712	Right MB Side Barrier	NS	-	55C682254P2	1
713	Front Motor Trough Barrier	9/12	55C682293G1	55C682293G2	1
715	Compartment Barrier-Left Side	8	55C682279P1	55C682279P2	1
716	Bottom MB Barrier	NS	55C682281P1	55C682281P2	1
717	Compartment Barrier-Right Side	8	55C682286P2	55C682286P2	1
718	Upper VB Insulation	11	55C682295P1	55C682295P1	1
719	Lower VB Insulation	11	55C682295P2	55C682295P2	1
720	Drawout Slide Supt.	10	55B534938P1	55B534938P1	2
722	Motor Cable Trough Side Barrier	9/12	55C682294P1	55C682294P1	1
724	Cont. Load Side Connector Base (Drawout)	8	55C685941G1	55C685941G1	1
724	Cont. Load Side Connector Base (Stationary)	10	55C685925G1	55C685925G1	1
726	QMQB	7/9	55C68220G3	55C68220G3	1
728	Cont. Position Interlock (Drawout)	7	55B534963G1	55B534963G1	1
762	VB Stab Supt.	11	55C685927G1	55C685927G1	1
763	Switch & Upper Fuse Supt.	7/9	55D781301G* ⑤	55D781301G* ⑤	1
764	Lower Fuse Supt.	7/9/10	55B533212G* ⑤	55B533212G* ⑤	1
765	Cont. Line Side Stab Asm., Drawout	8	55C685945G1	55C685945G1	1
789	Switch Barriers-Upper Section	7	55C685928G1	55C685928G1	1
789	Switch Barriers-Lower Section	9	55C685928G2	55C685928G2	1
790	Cont. Slide Stop	8/10	55B528996G1	55B528996G1	1
803	Power Fuse	6	see Panel Data NP for fuse part number	see Panel Data NP for fuse part number	3
864	Bus End Cover, Asm.	5	55C685931G1	55C685931G1	2
869	Top Motor Cable Trough Cover	NS	55C685905P1	55C685905P2	2
870	Cont. Lift Truck	NS	55B534913P1	55B534913P1	1

AR As Required

NS Not Shown

① See GEF-8016

② See Tables 5 and 6

③ See Table 10

④ See Table 9

⑤ Add suffix (*) per plating finish:

1=no plating, 2=Silver, 3=Tin.

⑥ See Table 11



Two-High (continued)

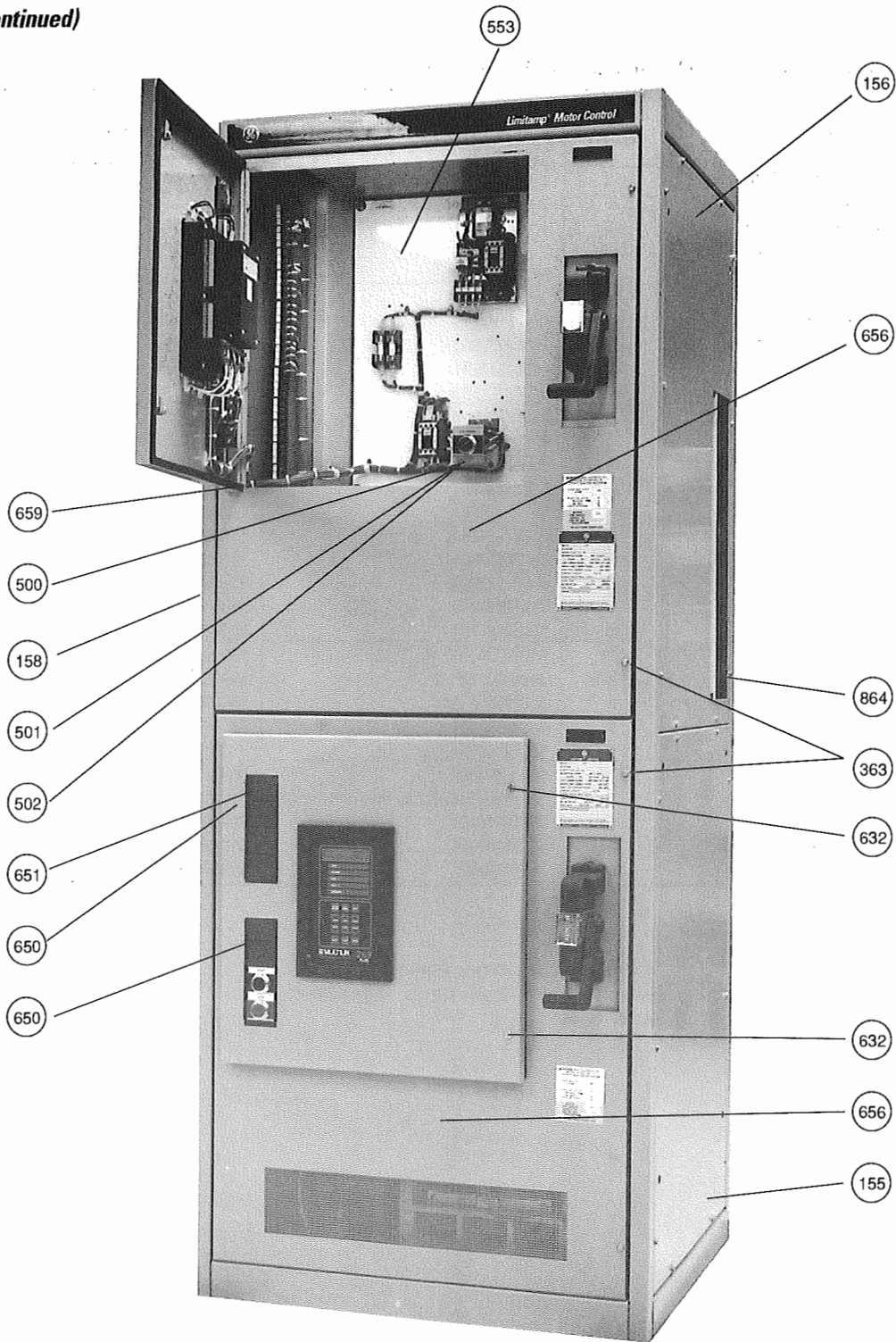

Figure 5. CR194 Two-High with Upper Low-Voltage Door Open

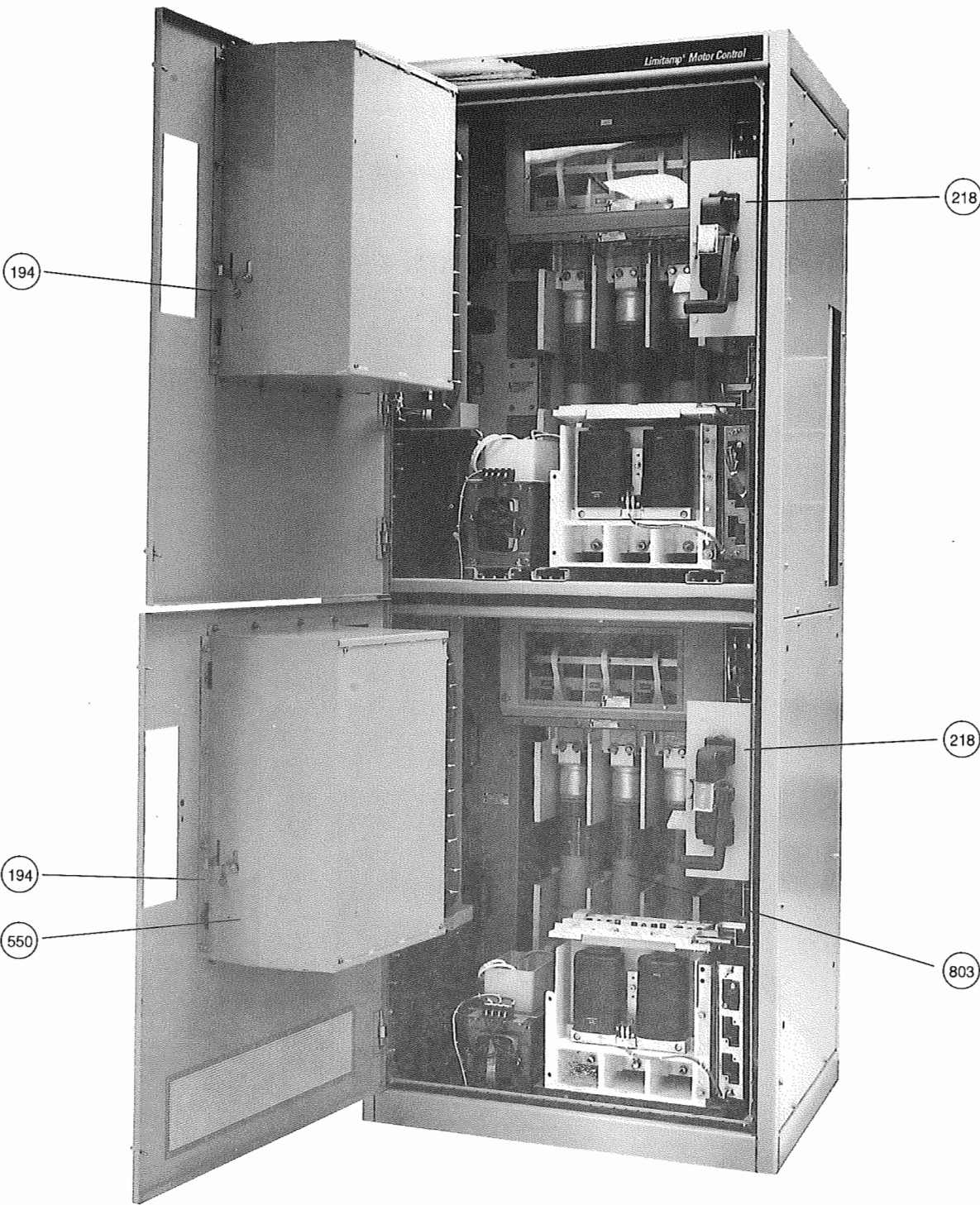

Figure 6. CR194 36" Wide Two-High with Both High-Voltage Doors Open



Two-High (continued)

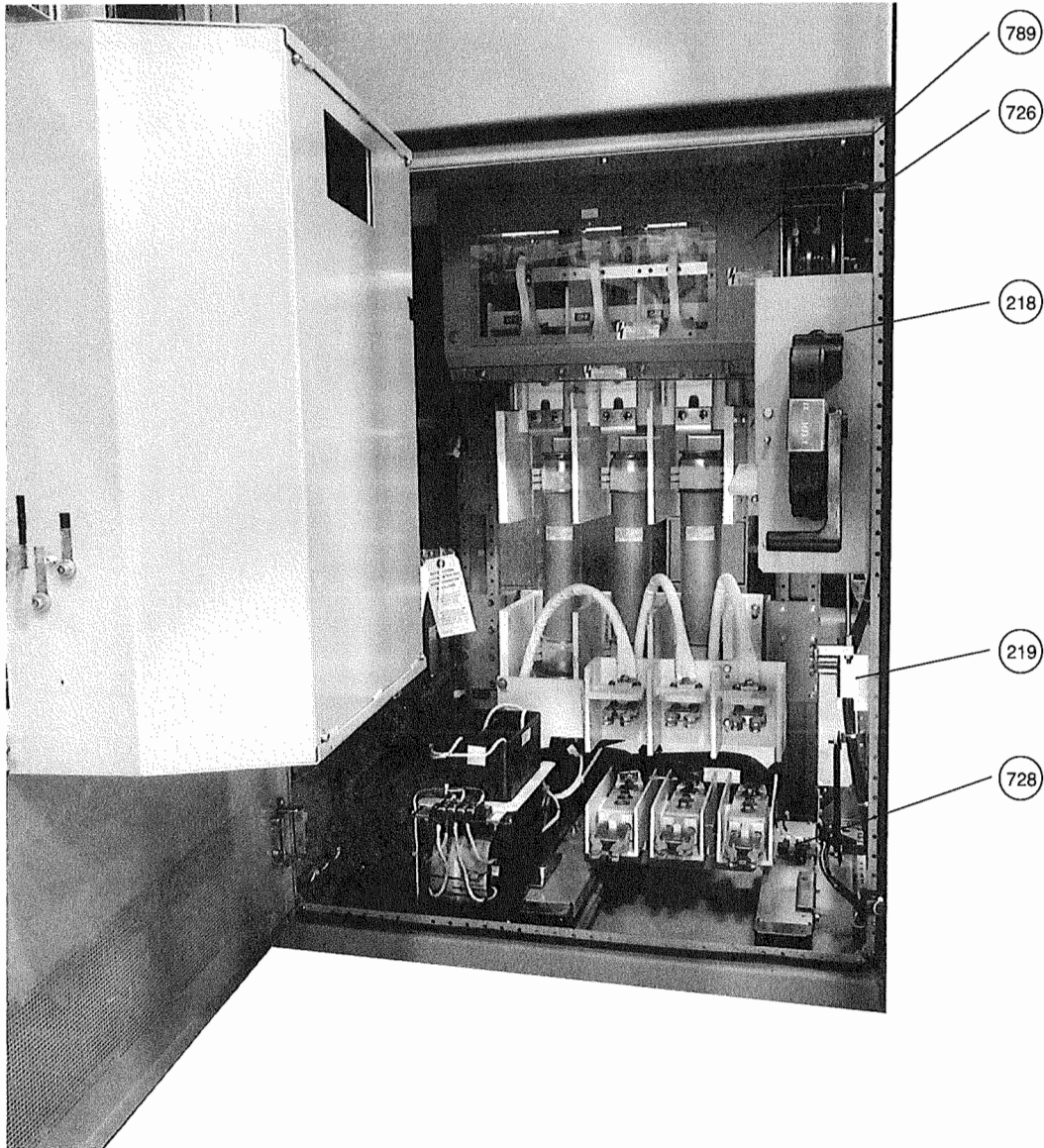

Figure 7. High-Voltage Section — Drawout Contactor

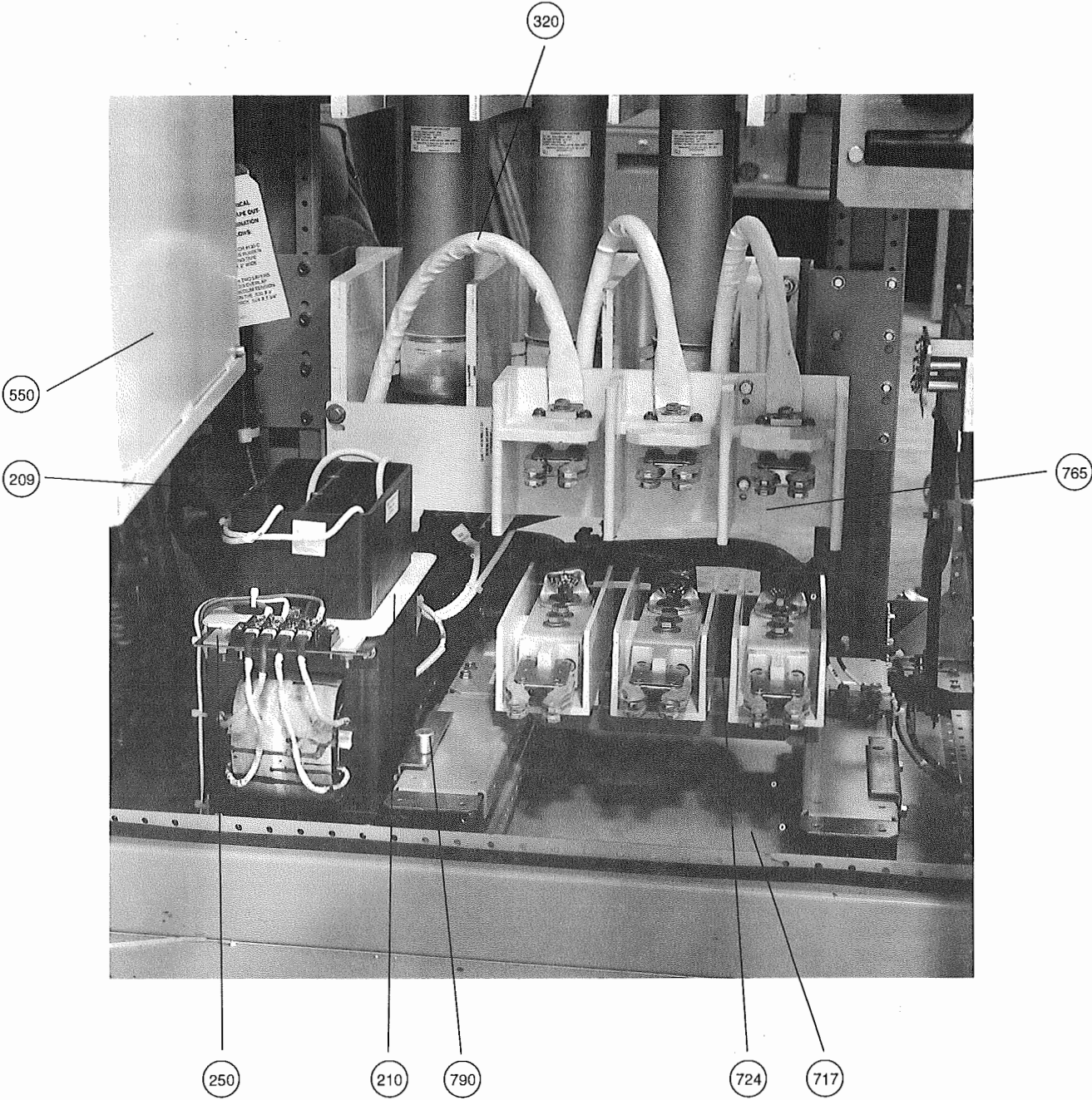

Figure 8. High-Voltage Drawout Contactor Components



Two-High (continued)

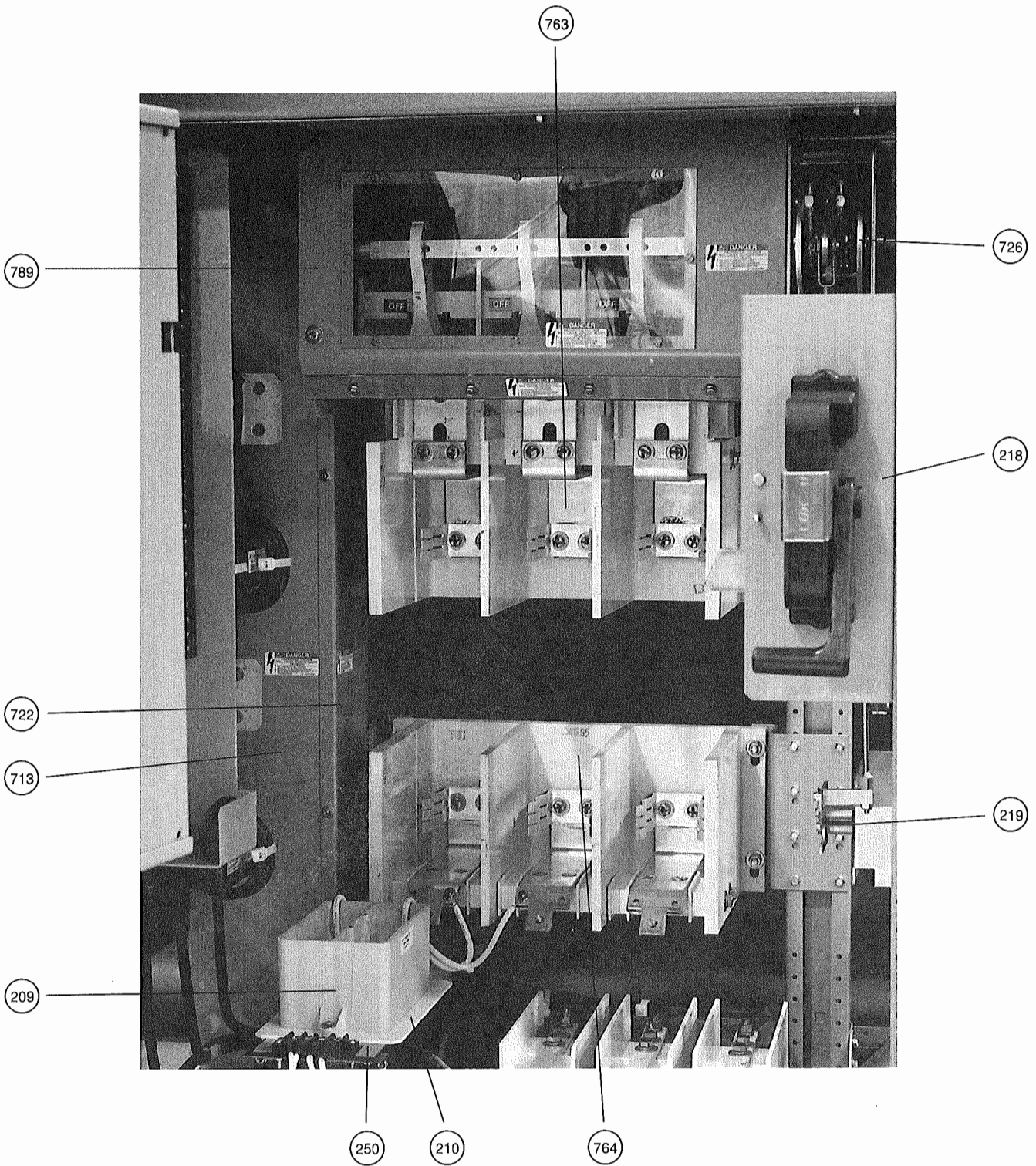

Figure 9. High-Voltage Section — Stationary Contactor

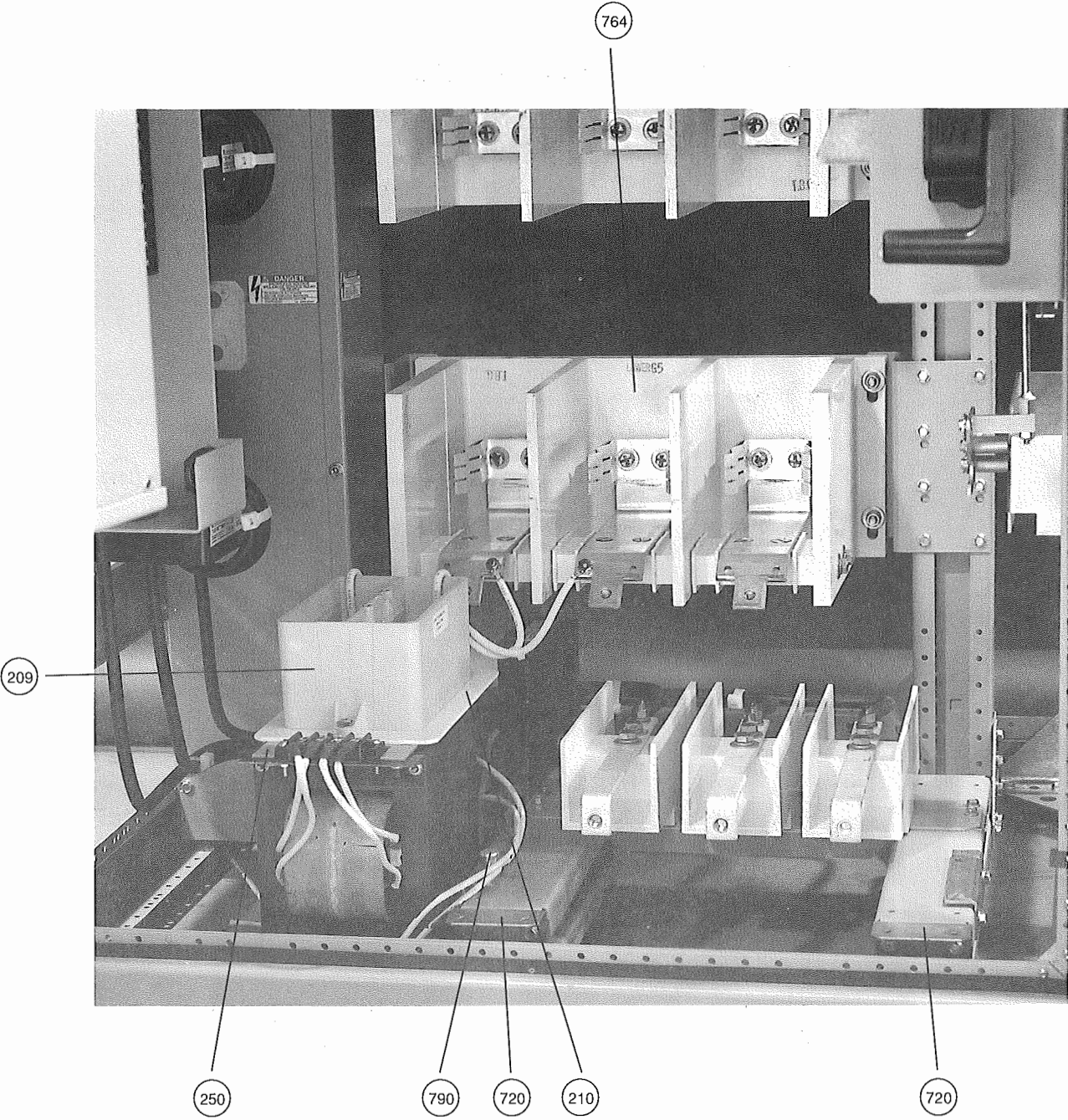

Figure 10. High-Voltage Stationary Contactor Components



Two-High (continued)

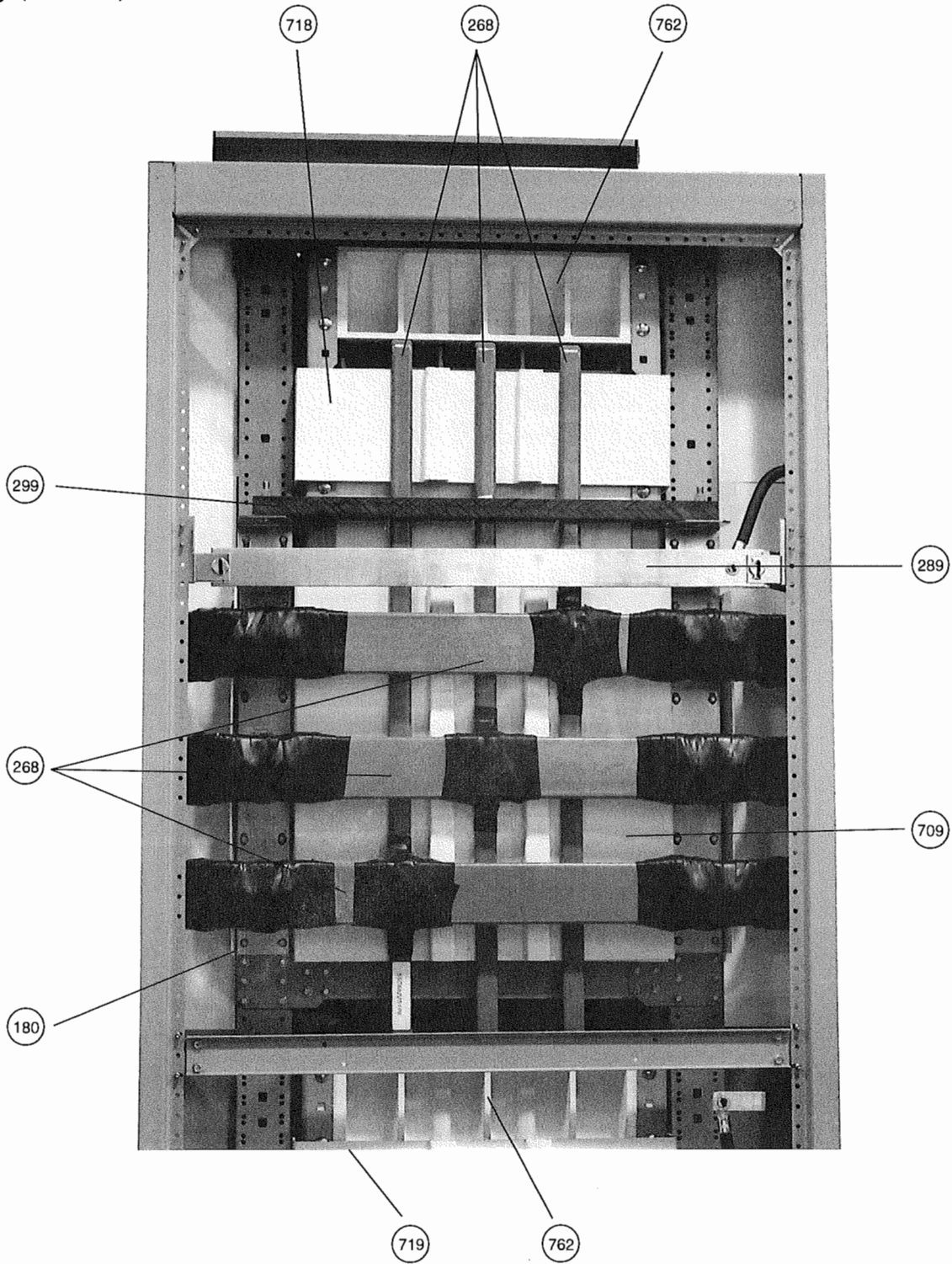

Figure 11. Main/Vertical Bus — Rear View

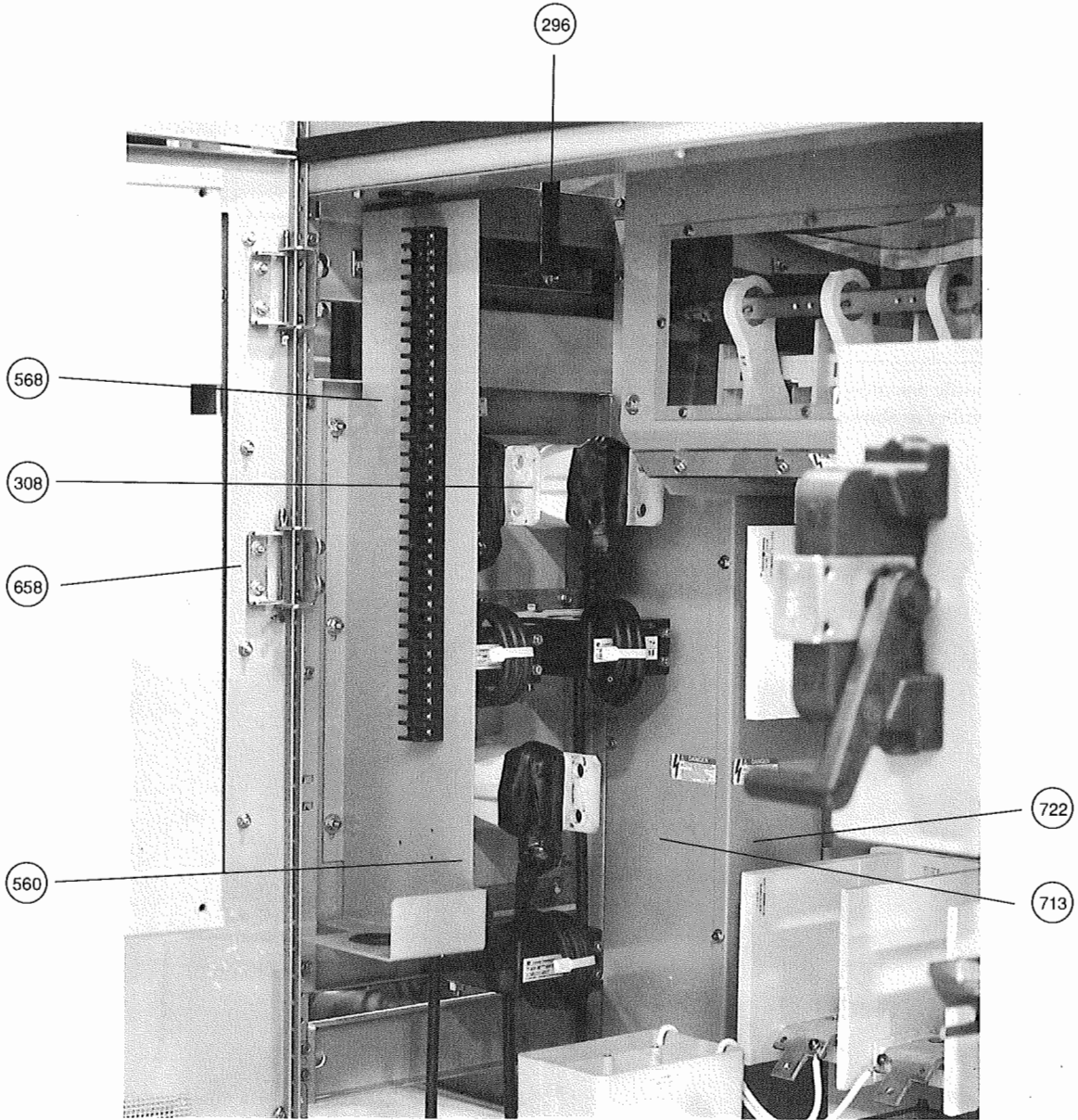

Figure 12. Typical Motor Terminal Area



Handle Assembly

The non-load break isolating mechanism (handle assembly) is a complex assembly requiring a special bench fixture for assembly and special gauges for adjustment of the mechanical interlocking mechanisms. We recommend, therefore, that the entire assembly be replaced if the handle mechanism becomes extensively damaged. Entire assemblies are ordered by catalog number (see Table 5). The group number (G*) is found on an adhesive backed label stuck on the underside of the handle housing (see Figures 13 and 14). Entire assemblies can be ordered as follows:

Table 5.
CR194 Vacuum Handle Assemblies

Type of Starter Unit	One-High Part Number	Two-High Part Number
Full-voltage non-reversing	302A3749G1	55D781326G1
Reduced-voltage non-reversing	302A3749G5	-
Full-voltage reversing-standard	302A3749G5	-

Some parts of the handle assembly are replaceable and can be identified by part number as shown in Table 6.

Table 6.
CR194 Handle Assembly Detail (see Figures 13 and 14)

Figure Item Number	Part Description	One-High Part Number	Two-High Part Number
1	Test power interlocks	IC2956A200BE	IC2956A200BE
2	Test power interlock bracket	68J122214NJ0000AAY	55B534910P1
3	Control power interlocks	723B245G274	723B245G274
4	Handle housing-standard	149B1759G1	149B1759G1
4	Handle housing-if key interlocked	149B1759AAP1	149B1759AAP1
5	Handle-standard	149B1746G1	149B1746G1
5	Handle-if key interlocked	194A7179P1	194A7179P1
6	Connecting rod	55B533058G1	55B533058G2
7	Handle retainer clip	N910P62C6	N910P62C6

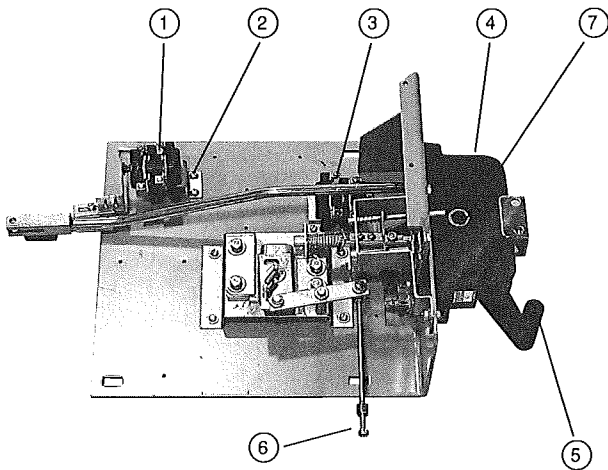

Figure 13. CR194 One-High Handle Assembly

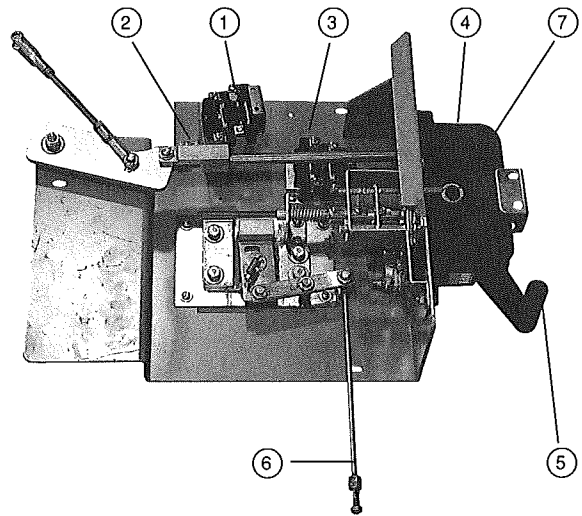

Figure 14. CR194 Two-High Handle Assembly



Bus Assembly
One-High

Table 7.
CR194 One-High Vacuum Ground Bus Parts

Part Description	Part Number
Copper 400A	55C682233P1* ❶
Copper 600A	55C682233P4* ❶
Copper/Tin Plated 400A	55C682233P2* ❶
Copper/Tin Plated 600A	55C682233P5* ❶
Copper/Silver Plated 400A	55C682233P3* ❶
Copper/Silver Plated 600A	55C682233P6* ❶

❶ Contact factory for proper splice part number. Add suffix (*) J for 26" wide or N for 34" wide.

Table 8.
CR194 One-High Vacuum Horizontal Bus Assembly Parts

Part Description	Part Number
Copper 1200A	55C682232P1* ❶
Copper 2000A	55C682232P1* ❶ ❷
Copper/Tin Plated 1200A	55C682232P3* ❶
Copper/Tin Plated 2000A	55C682232P3* ❶ ❸
Copper/Silver Plated 1200A	55C682232P2* ❶
Copper/Silver Plated 2000A	55C682232P2* ❶ ❹

- ❶ Consult factory for suffix (*) catalog number and for proper splice part numbers.
- ❷ Use QTY 6 908B101P29 spacers per section. Order QTY 2 per phase.
- ❸ Use QTY 6 908B101P31 spacers per section. Order QTY 2 per phase.
- ❹ Use QTY 6 908B101P30 spacers per section. Order QTY 2 per phase.

Fuse Support Assemblies

Table 11.
CR194 Upper and Lower Fuse Support Assembly Parts

Description	Part Number	Fuse Type				Fuse Voltage		Contactor Type		With Blown Fuse Indicator	Without Blown Fuse Indicator
		Clip		Bolted		5.0KV	7.2KV	Drawout	Stationary		
		Single Barrel	Double Barrel	Single Barrel	Double Barrel						
Upper Fuse Support (Item #763)	55D781301G1			X	X	X		X	X	X	
	55D781301G2			X	X		X	X	X	X	
	55D781301G5	X	X			X	X	X	X		X
	55D781301G4			X	X		X	X	X		X
	55D781301G3			X	X	X		X	X		X
Lower Fuse Support (Item #764)	55B533212G1				X	X		X		N/A	N/A
	55B533212G3				X		X	X		N/A	N/A
	55B533212G8				X	X		X		N/A	N/A
	55B533212G4			X			X	X		N/A	N/A
	55B533212G9			X		X		X		N/A	N/A
	55B533212G7		X			X			X	N/A	N/A
	55B533212G10	X	X			X	X ❶	X		N/A	N/A
55B533212G5	X				X	X		X	N/A	N/A	

❶ 7.2KV clip fuses limited to single barrel only.

Two-High

Table 9.
CR194 Two-High Vacuum Ground Bus Parts

Part Description	Part Number 36" Wide	Part Number 40" Wide	Splice
Copper 400A	55C682290P3N	55C682290P4N	❶
Copper 600A	55C682290P1N	55C682290P2N	❶
Copper/Tin Plated 400A	55C682290P3T	55C682290P4T	❶
Copper/Tin Plated 600A	55C682290P1T	55C682290P2T	❶
Copper/Silver Plated 400A	55C682290P3S	55C682290P4S	❶
Copper/Silver Plated 600A	55C682290P1S	55C682290P2S	❶

❶ Contact factory for proper splice part number.

Table 10.
CR194 Two-High Horizontal and Vertical Bus Assembly Parts

Part Description	Part Number 36" Wide	Part Number 40" Wide	Splice
Copper 1200A	55C685920G1	55C685920G19N	❶
Copper 2000A	55C685920G4	55C685920G20N	❶
Copper/Tin Plated 1200A	55C685920G2	55C685920G19T	❶
Copper/Tin Plated 2000A	55C685920G5	55C685920G20T	❶
Copper/Silver Plated 1200A	55C685920G3	55C685920G19S	❶
Copper/Silver Plated 2000A	55C685920G6	55C685920G20S	❶

❶ Contact factory for proper splice part number

* Catalog numbers shown include all vertical and horizontal bus bars and spacers.



These instructions do not purport to cover all details or variations in equipment nor to provide for every possible contingency to be met in connection with installation, operation or maintenance. Should further information be desired or particular problems arise that are not covered sufficiently for the Purchaser's purposes, the matter should be referred to the nearest GE sales office.

