



Spectra Series™ Power Panelboards

Bolt-On Circuit Breaker Kits

Application

These instructions apply to bolt-on circuit breaker kits with catalog numbers AMCB3GM and AMCB2GM.

For use with circuit breaker types SGH, SGL, and SGP.

For use with circuit breaker cover kit AFP4SGS.

Replacement hardware kit: AHKBG1.

Installation



WARNING: Danger of electrical shock or injury. Turn OFF power ahead of the panelboard or switchboard before working inside the equipment or removing any component. Equipment is to be installed and maintained by properly trained and qualified personnel only.

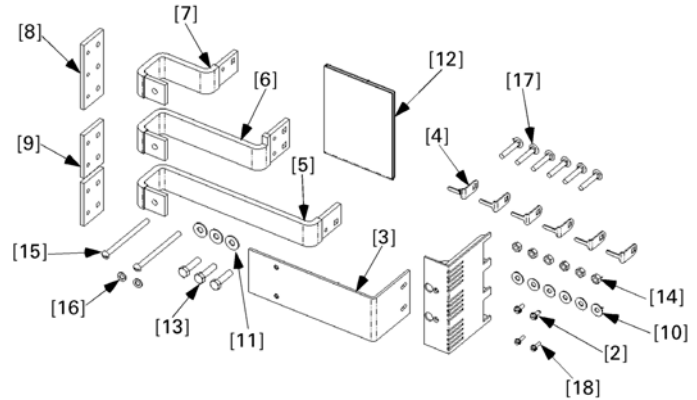

Figure 1. Parts included in the kits AMCB2GM and AMCB3GM.

In the following instructions numbers in brackets in the text and figures refer to the items in Table 1.

- 1. Confirm the contents of the kit.** These kits are used to install main and single-branch G-frame Spectra circuit breakers into Spectra APNB bolt-on-style interiors. The vertical space required for each kit is 5.50 inches (4X).

Figure 1 illustrates the parts included in this kit, which are listed in Table 1.

Item	Part #	Description	Qty. in AMCB2GM	Qty. in AMCB3GM.
1	10083041P1	Terminal cover	1	1
2	192A6976P189	Thread-forming screw, #10-32 x 7/16"	2	2
3	252B3576P1	Circuit breaker mounting bracket	1	1
4	252B3613P1	Antiturn clip	4	6
5	252B3618G13	G frame single strap	1	1
6	252B3618G14	G frame single strap	1	1
7	252B3618G15	G frame single strap	1	1
8	252B3657P1	Spacer	1	1
9	252B3657P2	Spacer	2	2
10	75A105503P101	Conical spring washer, 1/4"	4	6
11	75A105503P105	Conical spring washer, 5/16"	2	3
12	DEH060	Installation instructions	1	1
13	N22P23016B6	Hex-head bolt, 3/8-16 x 1"	2	3
14	N245P21B6	Nut, 1/4-20	4	6
15	N37P21060B6	Screw, 1/4-20 x 33/4"	2	2
16	N402P11B6	Flat washer, 1/4"	2	2
17	N657P21024B6	Carriage bolt, 1/4-20 x 11/2"	4	6
18	N730BP1308B6	Thread-forming screw, #6 x 1/2"	2	2

Table 1. Parts list for kits AMCB2GM and AMCB3GM.

2. **Locate the side of the interior with a 2.75-inch reference distance.** The circuit breaker straps are mounted on the side of the panel interior bus at which the distance from the vertical bus face to the inner face of the bus-support rail is 2.75 inches, as indicated in Figure 2.



NOTE: The following assembly views show the 2.75-inch distance on the right. When this reference distance is on the left, the proper view is upside down.

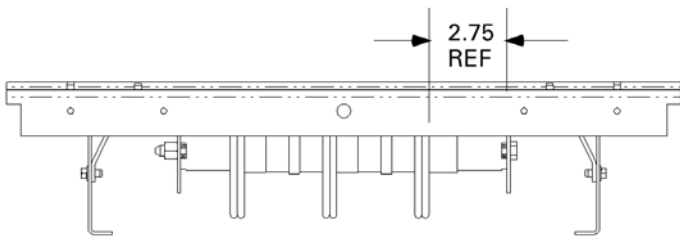

Figure 2. Illustration of the 2.75-inch reference distance.

3. **Assemble antiturn clips onto carriage bolts.** Slide an antiturn clip [4] over the square shank of each carriage bolt [17], as shown in Figure 3. Figure 4 illustrates the installation of a bolt and antiturn clip onto the interior, as called for in the remaining steps.

When the breaker cable connection is on the same side as the 2.75" reference dimension of the interior, as illustrated in Figure 2, then only three each (for kit AMCB3GM) or two each (for kit AMCB2GM) of items [4] and [17] are used, with no spacers [8, 9]. When the cable connections are on the opposite side, then six each (for kit AMCB3GM) or four each (for kit AMCB2GM) of items [4] and [17] are used, along with spacers [8, 9].

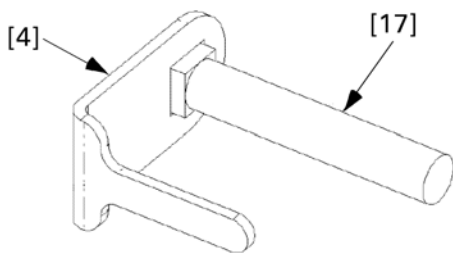

Figure 3. Assembling an antiturn clip [4] with a carriage bolt [17].

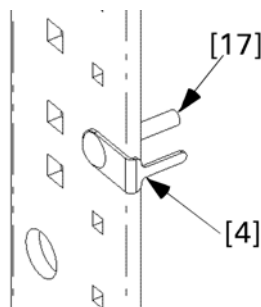

Figure 4. Installing a carriage bolt [17] and antiturn clip [4] into the interior.



NOTE: If the breaker cable connection is on the same side of the interior as the 2.75" reference dimension, proceed with step 4. If the cable connection is on the opposite side of the interior as the 2.75" reference dimension, proceed to step 5.

4. **Strap assembly procedure with cable connection on the same side as the 2.75" distance.** For single-phase and dc applications using the bus closest to the bus support, go to step 4c. For single-phase and dc applications using the middle vertical bus and the vertical bus on the opposite side of the 2.75" reference, go to step 4e.

4a. **For three-phase assembly (kit AMCB3GM).** Position the carriage bolt [17] and antiturn clip [4] assemblies as shown in Figures 5 and 6.

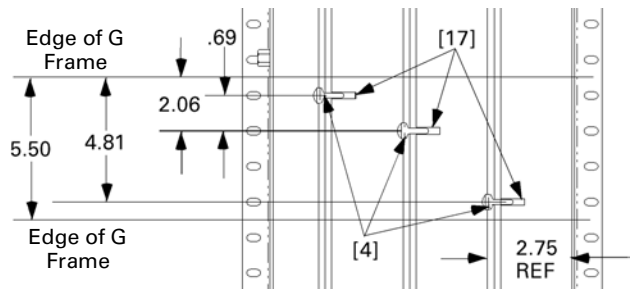

Figure 5. Carriage bolt and antiturn clip installation for three-phase connections.

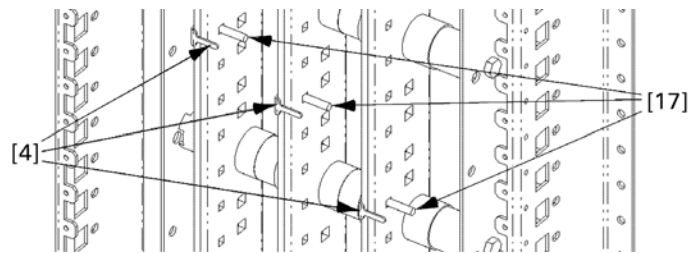

Figure 6. Carriage bolt and antiturn clip installation for three-phase connections, isometric view.

4b. **Install straps.** Place the G frame single straps [5, 6, 7] over the carriage bolts and antiturn clips, as shown in Figures 7 and 8. Place conical washers [10] on the bolts and secure with nuts [14]. Leave the connections finger tight.

If the group assembly selection is three-phase, with the cable connections on the same side as the 2.75" reference dimension, and the assembly looks like Figure 8, then go to step 6.

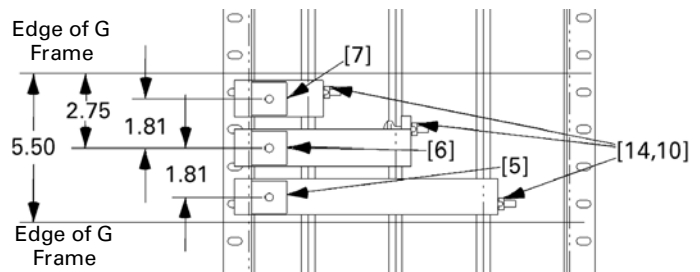

Figure 7. Installing the straps for three-phase connections.

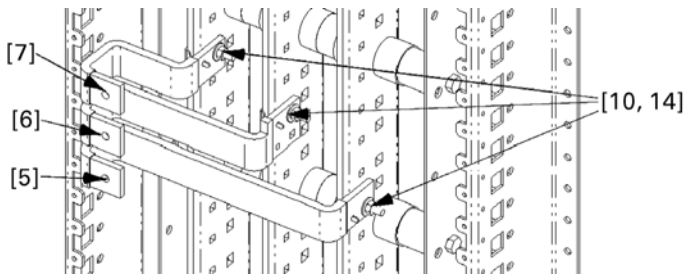

Figure 8. Installing the straps for three-phase connections, isometric view.

4c. Connections to the outer bus of three-phase interiors, with straps on single-phase interiors using this assembly. For applications using the center bus go to step 4e.

Position the carriage bolts [17] and antiturn clips [4] as shown in Figures 9 and 10.

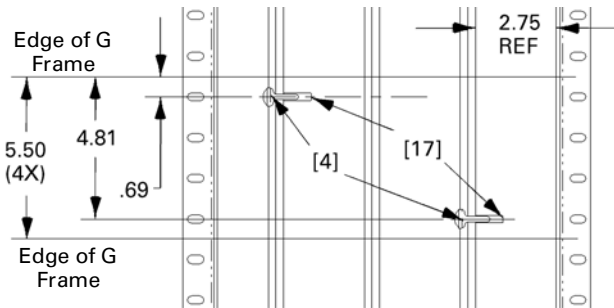

Figure 9. Carriage bolt and antiturn clip installation for connections to the outer bus of three-phase interiors.

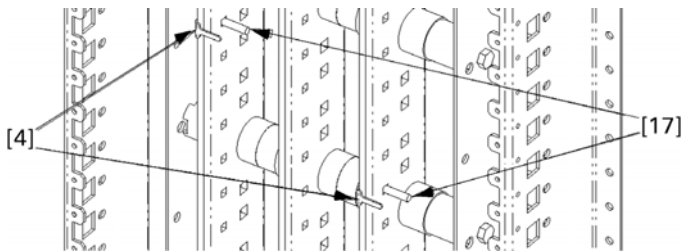

Figure 10. Carriage bolt and antiturn clip installation for connections to the outer bus of three-phase interiors, isometric view.

4d. Install straps. Place the G frame single straps [5, 7] over the carriage bolts and antiturn clips, as shown in Figures 11 and 12. Place conical washers [10] on the bolts and secure with nuts [14]. Leave the connections finger tight.

If the group assembly selection is for connections to the outer vertical bus with the cable connections on the same side as the 2.75" reference dimension, and the assembly looks like Figure 12, then go to step 6.

4e. Strap connections to the middle vertical bus and the vertical bus opposite the 2.75" reference dimension.

Position the carriage bolts [17] and antiturn clips [4] as shown in Figures 13 and 14.

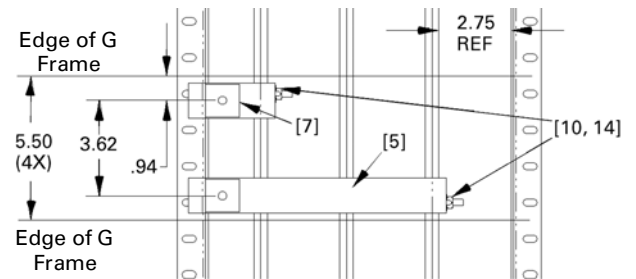

Figure 11. Installing the straps for connections to the outer bus of three-phase interiors.

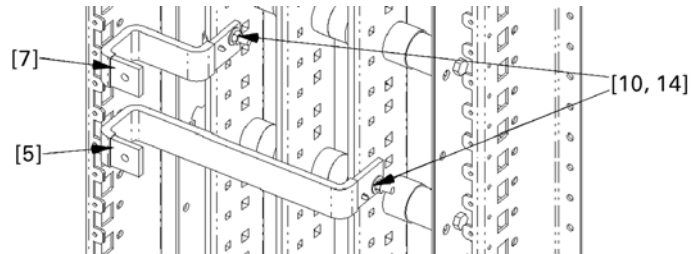

Figure 12. Installing the straps for connections to the outer bus of three-phase interiors, isometric view.

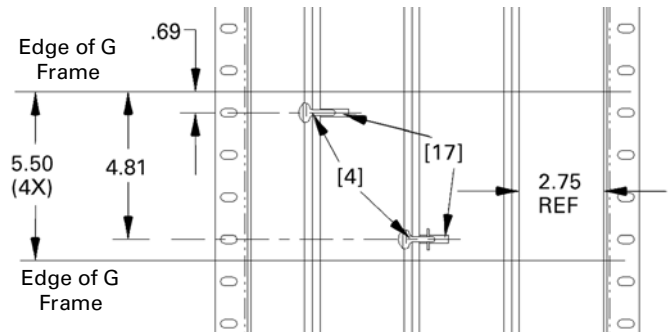

Figure 13. Carriage bolt and antiturn clip installation for single-phase applications with connections to the middle vertical bus.

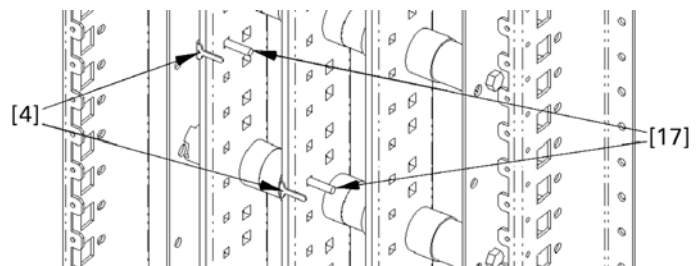

Figure 14. Carriage bolt and antiturn clip installation for single-phase applications with connections to the middle vertical bus, isometric view.

4f. Install straps. Place the G frame single straps [6, 7] over the carriage bolts and antiturn clips, as shown in Figures 15 and 16. Place conical washers [10] on the bolts and secure with nuts [14]. Leave the connections finger tight.

If the group assembly selection is for connections to the outer vertical bus with the cable connections opposite to the 2.75" reference dimension, and the assembly looks like Figure 16, then go to step 6.

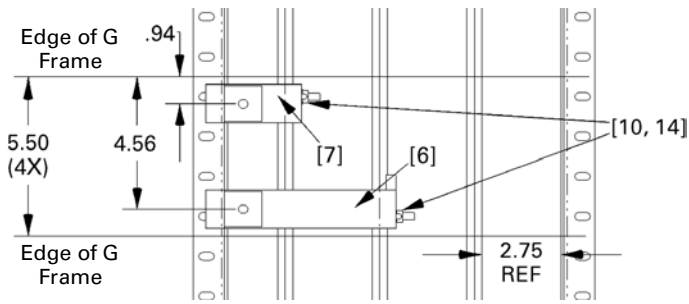

Figure 15. Installing the straps for single-phase applications with connections to the middle vertical bus.

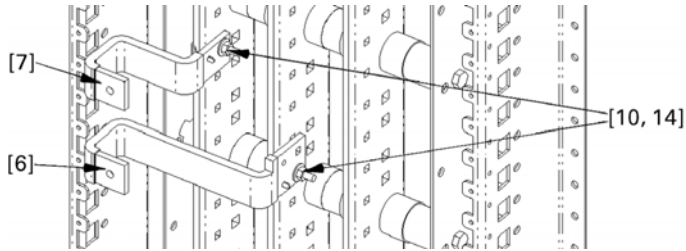

Figure 16. Installing the straps for single-phase applications with connections to the middle vertical bus, isometric view.

5. Strap assembly procedure with cable connection on the opposite side from the 2.75" distance. For single-phase and dc applications using the bus closest to the bus support, go to step 5c. For single-phase and dc applications using the middle vertical bus and the vertical bus on the opposite side of the 2.75" reference, go to step 5e.

5a. For three-phase assembly (kit AMCB3GM). Position the carriage bolts [17], antiturn clips [4], and spacers [8, 9] as shown in Figures 17 and 18.

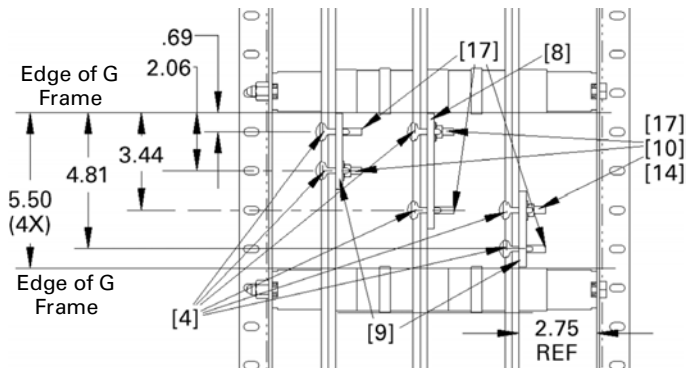

Figure 17. Carriage bolt, antiturn clip, and spacer installation for three-phase connections.

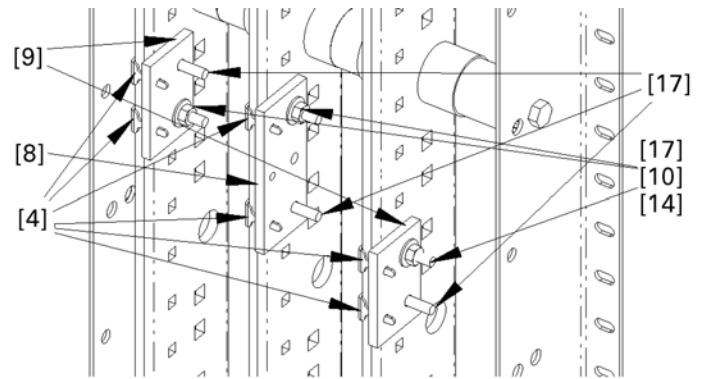

Figure 18. Carriage bolt and antiturn clip installation for three-phase connections, isometric view.

5b. Install straps. Place the G frame single straps [5, 6, 7] over the carriage bolts and antiturn clips, as shown in Figures 19 and 20. Place conical washers [10] on the bolts and secure with nuts [14]. Leave the connections finger tight.

If the group assembly selection is three-phase, with the cable connections on the opposite side from the 2.75" reference dimension, and the assembly looks like Figure 20, then go to step 6.

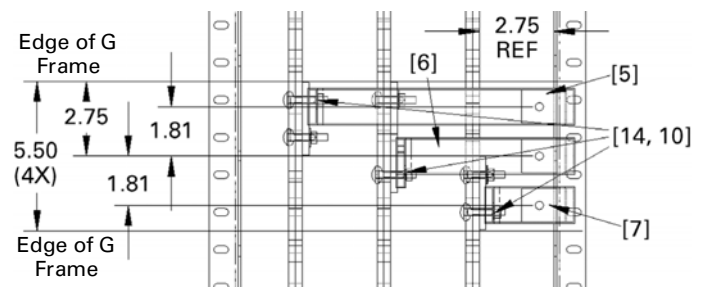

Figure 19. Installing the straps for three-phase connections.

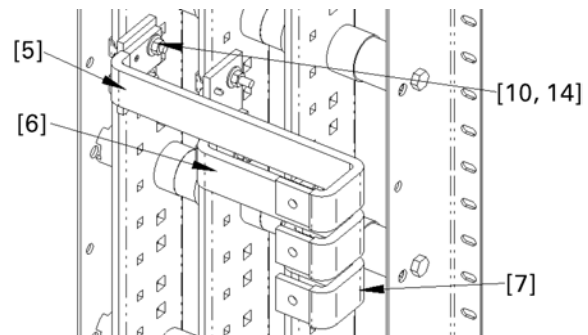

Figure 20. Installing the straps for three-phase connections, isometric view.

5c. Connections to the outer bus of three-phase interiors, with straps on single-phase interiors using this assembly. For phase-balancing applications using the center bus go to step 5e.

Position the carriage bolts [17], antiturn clips [4], and spacers [9] as shown in Figures 21 and 22. Place conical washers [10] on the bolts shown and secure with nuts [14]. Leave the connections finger tight.

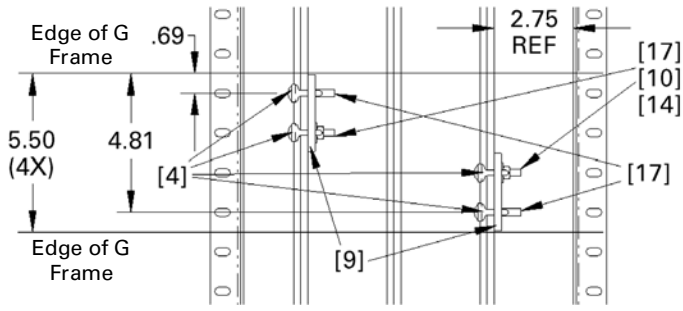

Figure 21. Carriage bolt, antiturn clip, and spacer installation for connections to the outer bus of three-phase interiors.

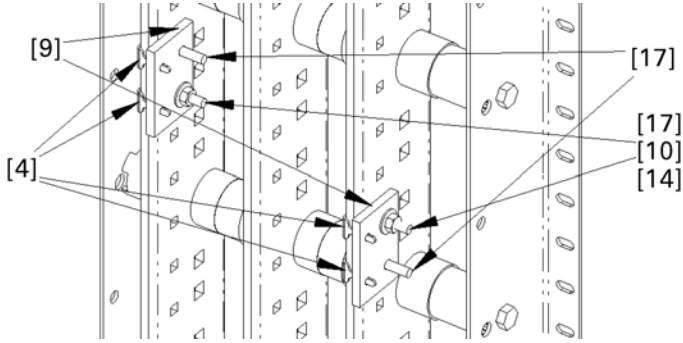

Figure 22. Carriage bolt, antiturn clip, and spacer installation for connections to the outer bus of three-phase interiors, isometric view.

5d. Install straps. Place the G frame single straps [5, 7] over the carriage bolts and antiturn clips, as shown in Figures 23 and 24. Place conical washers [10] on the bolts and secure with nuts [14]. Leave the connections finger tight.

If the group assembly selection is for connections to the outer vertical bus with the cable connections on the opposite side from the 2.75" reference dimension, and the assembly looks like Figure 24, then go to step 6.

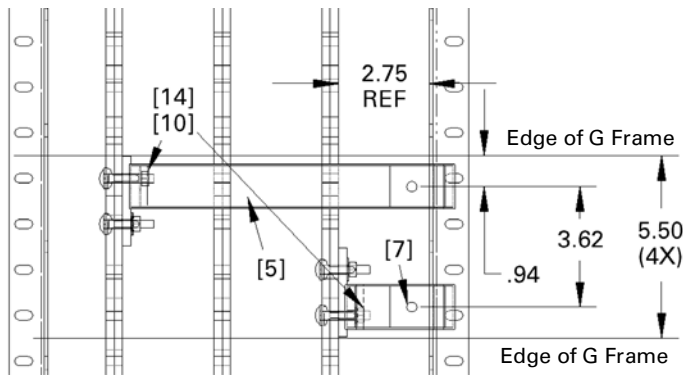

Figure 23. Installing the straps for connections to the outer bus of three-phase interiors.

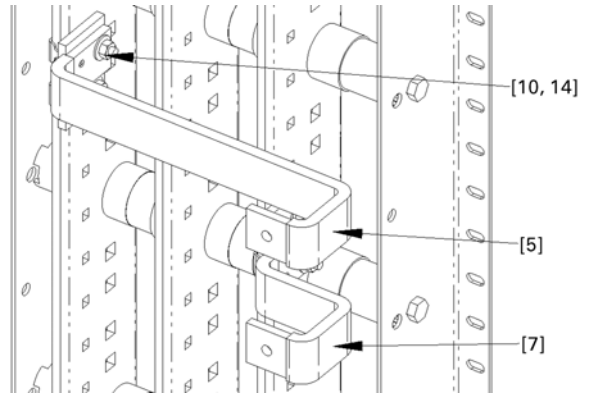

Figure 24. Installing the straps for connections to the outer bus of three-phase interiors, isometric view.

5e. Strap connections to the middle vertical bus and the vertical bus on the same side as the 2.75" reference dimension.

Position the carriage bolts [17], antiturn clips [4], and spacers [8, 9] as shown in Figures 25 and 26. Place conical washers [10] on the bolts shown and secure with nuts [14]. Leave the connections finger tight.

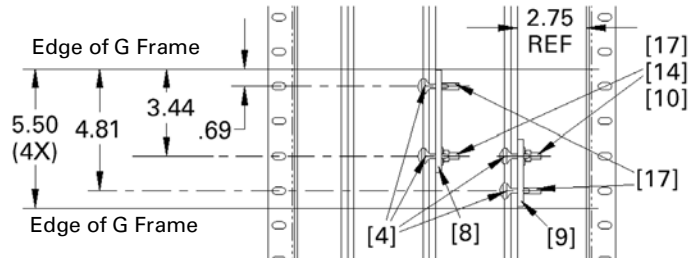

Figure 25. Carriage bolt, antiturn clip, and spacer installation for single-phase applications with connections to the middle vertical bus.

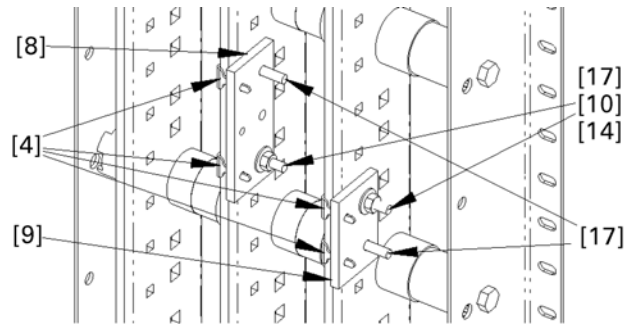

Figure 26. Carriage bolt, antiturn clip, and spacer installation for single-phase applications with connections to the middle vertical bus, isometric view.

5f. Install straps. Place the G frame single straps [6, 7] over the carriage bolts and antiturn clips, as shown in Figures 27 and 28. Place conical washers [10] on the bolts and secure with nuts [14]. Leave the connections finger tight.

If the group assembly selection is for connections to the outer vertical bus with the cable connections opposite to the 2.75" reference dimension, and the assembly looks like Figure 28, then go to step 6.

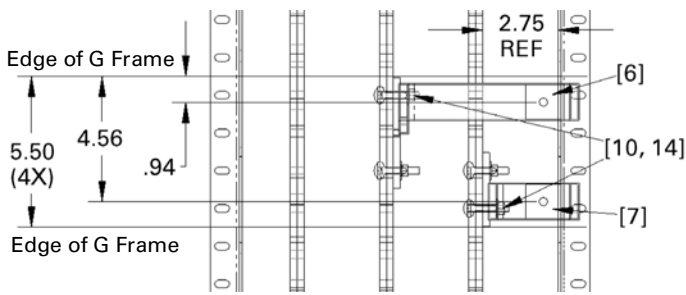

Figure 27. Installing the straps for single-phase applications with connections to the middle vertical bus.

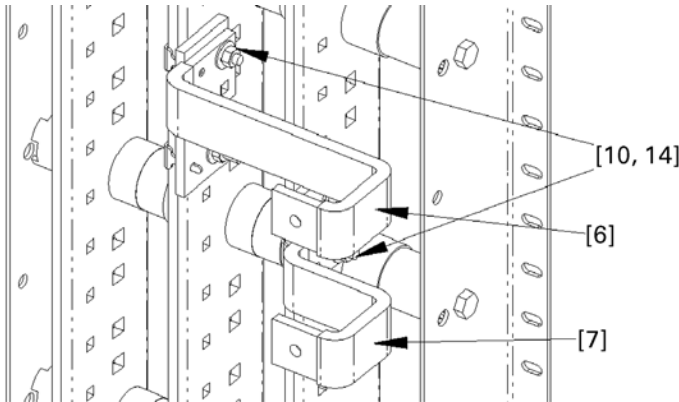

Figure 28. Installing the straps for single-phase applications with connections to the middle vertical bus, isometric view.

6. Install the circuit breaker mounting bracket. Secure the breaker mounting bracket [3] to the panel side rail with thread-forming screws [2]. Figures 29 and 30 show the installation for cable connections on the same side as the the 2.75" reference dimension. Figures 31 and 32 show the installation for cable connections on the opposite side from the 2.75" reference dimension. Tighten the thread-forming screws to 30 in-lb.

7. Install circuit breakers. Figure 33 illustrates circuit breaker installation. For main breaker operation, position the device so that the load- or OFF-side terminals rest on the straps and the opposite side is supported by the mounting bracket. For single-branch operation, mount the breaker so that the line- or ON-side terminals rest on the straps and the opposite side rests on the mounting bracket.

Align the holes in the breaker housing with the corresponding holes in the mounting bracket. Fasten the breaker to the bracket with the machine screws [17] and flat washers [16] and tighten to 50 in-lb.

Attach the breaker terminals to the threaded holes in the straps with the bolts [13] and conical washers [11]. Tighten each terminal to 75 in-lb.



NOTE: Straps may require minor adjustments for proper hole alignment.

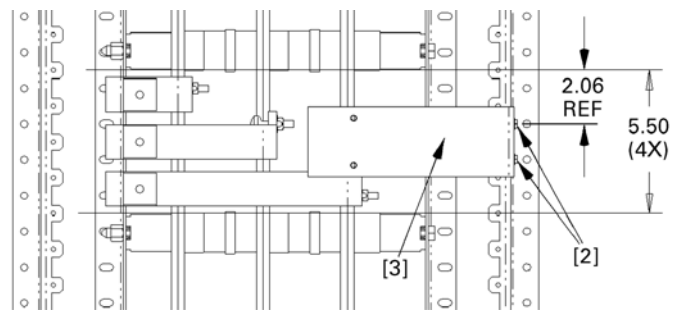

Figure 29. Installing the breaker mounting bracket for cable connections on the same side as the 2.75" reference dimension.

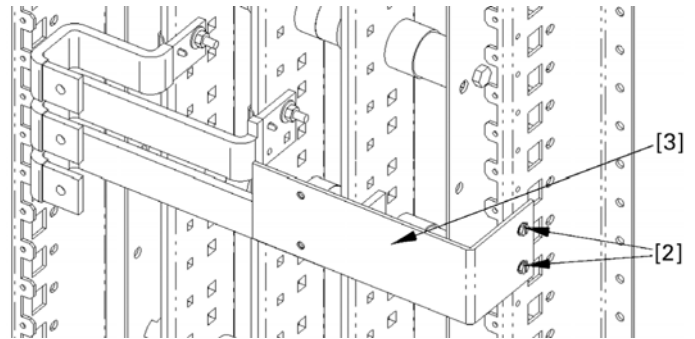

Figure 30. Installing the breaker mounting bracket for cable connections on the same side as the 2.75" reference dimension, isometric view.

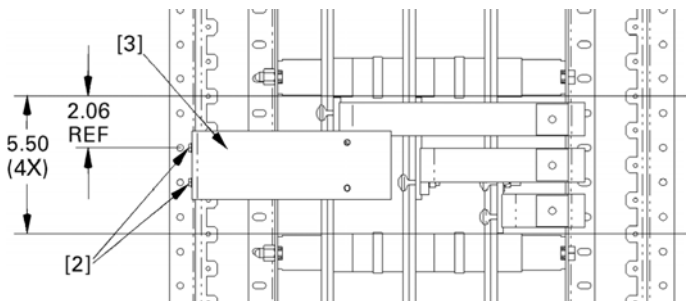

Figure 31. Installing the breaker mounting bracket for cable connections opposite the 2.75" reference dimension.

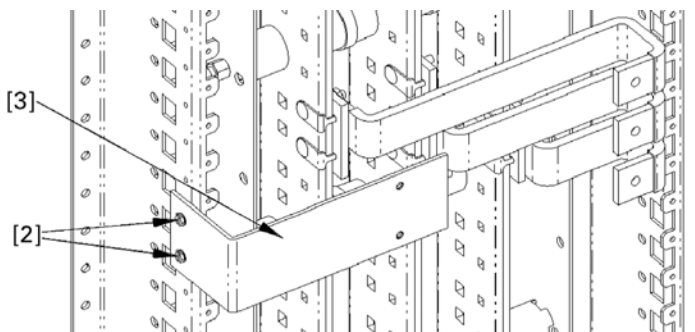

Figure 32. Installing the breaker mounting bracket for cable connections opposite the 2.75" reference dimension, isometric view.

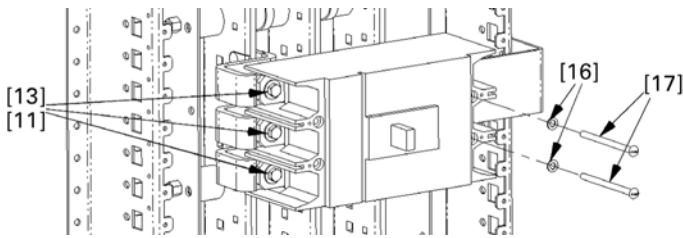

Figure 33. Installing a circuit breaker.

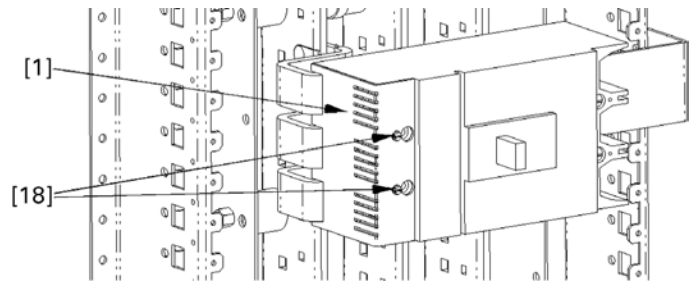

Figure 34. Installing the terminal cover on the breaker.

8. **Tighten the bolted connections.** Tighten the bolted strap connections to the vertical bus to 65 in-lb. It may be necessary to remove an adjacent breaker to allow access to the bolted connections at the vertical bus.
9. **Terminal cover installation.** Install the terminal cover [1] to the breaker with thread-cutting screws [18], as shown in Figure 34. A $\frac{3}{8}$ " x $\frac{3}{8}$ " relief hole must be made in the cover if the breaker is mounted as a main with an accessory cable (such as ground fault and communications) leaving the load end of the breaker.

10. **Breaker mounting configurations.** For phase-balancing, single-phase panels, and dc applications, refer to Figure 35 for the breaker mounting configurations available with these strap kits. When installing these strap configurations, be sure to use standard phase rotation, as required.

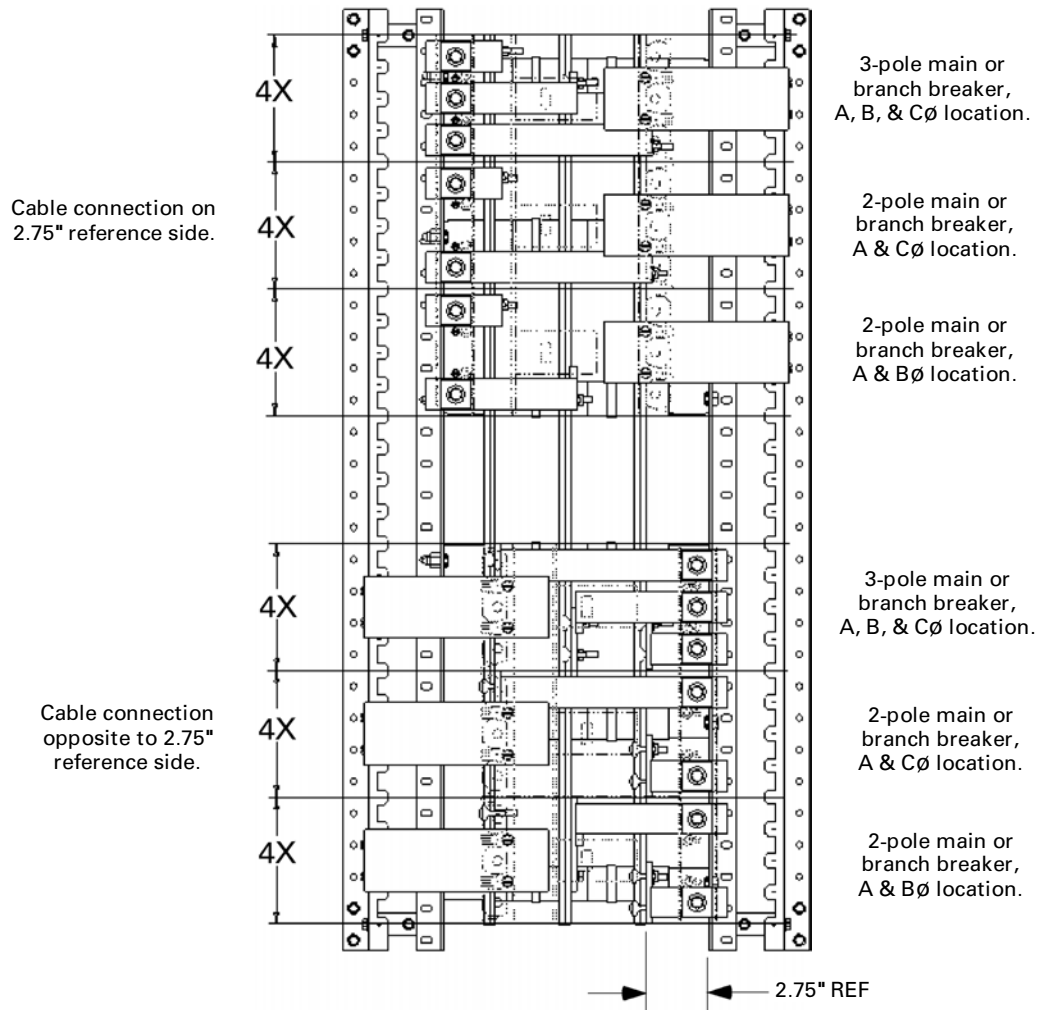

Figure 35. Possible bus strap combinations. Note that if the 2.75" reference dimension is on the left side of the panel, this diagram should be flipped 180° for the appropriate view.

These instructions do not cover all details or variations in equipment nor do they provide for every possible contingency that may be met in connection with installation, operation, or maintenance. Should further information be desired or should particular problems arise that are not covered sufficiently for the purchaser's purposes, the matter should be referred to the GE Company.



GE Industrial Systems