



Definite Purpose Contactors & Starters

CR453A Series Contactors CR454A Series Starters

Caution: Before installing in a nuclear application, determine that the product is intended for such use.

Warning: Disconnect power before installing or servicing.

Description

GE's CR453A magnetic contactors provide a 2- or 3-pole device for use in air conditioning units or other general purpose applications. These instructions give information about ratings, installation, accessories and wiring, overload relay may be added if needed. Factory assembled starters CR454A include overload relay.

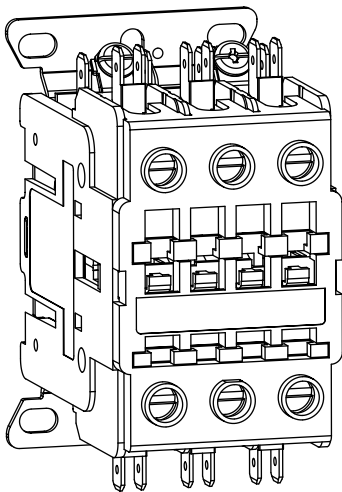

Typical CR453A Series contactor

Ratings – Full Voltage, Non-Reversing

Frame Size	VAC	Ratings				Resistive Rating Per Pole
		FLA	LRA	Horsepower		
				1 PH	3 PH	
CR453AB	120	25	150	2	–	35
	240		150	3	7.5	
	480		125	–	10	
	600		100	–	10	
CR453AC	120	30	180	2	–	40
	240		180	5	10	
	480		150	–	15	
	600		120	–	15	
CR453AD	120	40	240	3	–	50
	240		240	7.5	10	
	480		200	–	20	
	600		160	–	20	

Motor branch circuit and control circuit overcurrent protection should be supplied in accordance with the National Electrical Code or local code as required. CR453A contactors are suitable for use on a circuit capable of delivering not more than 5,000 RMS symmetrical amperes, 600 volts maximum when protected by fuses or a circuit breaker having an interrupting rating not less than 5,000 RMS symmetrical amperes.

Use 75° C copper conductors only.

Power Terminal Tightening Torque (lbs.-in.)

Terminal Type	Torque Values
Box Lug	40
Pressure Plate	20
Binding Screw	20

Contactor Installation

Before connecting to power supply:

1. Remove all packing.
2. Operate movable magnet and operating arm by pressing down on the operating arm from the front or side of the contactor to assure free movement.
3. Mount starter on a sturdy vertical support.
4. Make electrical connections as per wiring diagram.
For quick connect wiring, use UL recognized insulated terminals.

Mounting Hole Dimensions

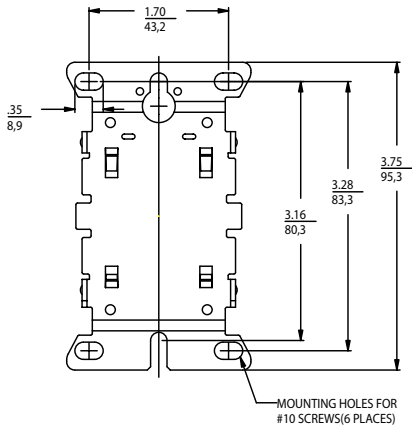

Contactor Wiring Diagram

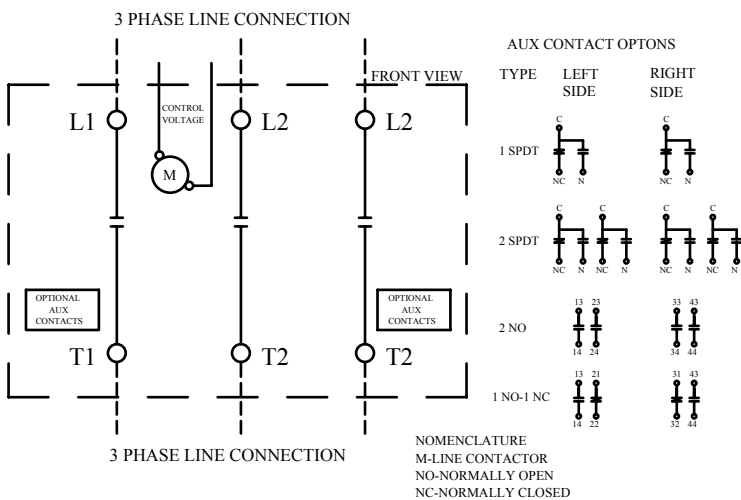

Starter Installation

1. Remove all packing.
2. *Motors with service factor of 1.15 or greater.*
 - Select overload relay as per the FLA shown in the motor nameplate.
 - Adjust the front mounted tripping current setting dial to the motor FLA.
2. *Motors with service factor less than 1.15*
 - Select overload relay as per the formula: Motor FLA (shown in the motor plate) x 0.09.
 - Adjust the front mounted tripping current setting dial to the result of the above mentioned motor FLA.
3. Operate movable magnet and operating arm by pressing down on the operating arm from the front or side of the contactor to assure free movement.
4. Mount starter on a sturdy vertical support.
5. Make electrical connections as per wiring diagram.
For quick connect wiring, use UL recognized insulated terminals.
6. Select the four modes by means of a front selector lever.
7. Overload relays features tripping indicator, independent & double break auxiliary tripping contacts (1NO+1NC) with welding check lever.
8. Overload relay features thermal protection against balanced overload, differential protection against unbalanced overloads and also ambient temperature compensation.

CR454A Series Starter Dimensions

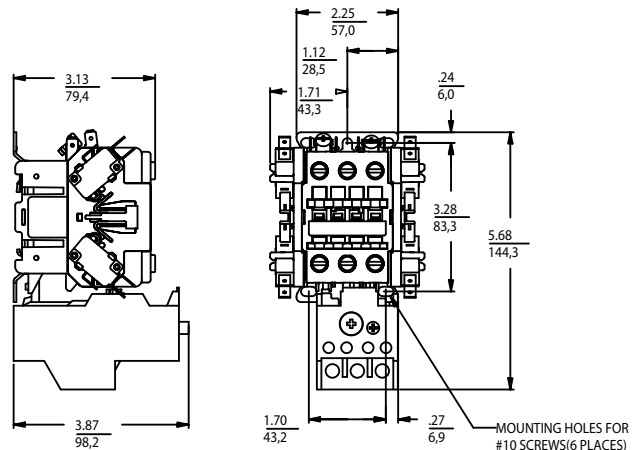

Check for Welded Contacts in Overload Relay

Disconnect power from device and control wiring from the terminals of the relay. Connect the bell set or resistance-measuring instrument across the relay terminals. Depress and release the reset arm to ensure the relay is reset. In this condition there should be continuity between the terminals.

In the tripped condition, the circuit between the terminals should be open indicating the contacts are operating normally. Remove the bell set or resistance measuring apparatus, rewire the relay terminals and reset the relay for normal operation.

Starter Wiring Diagram

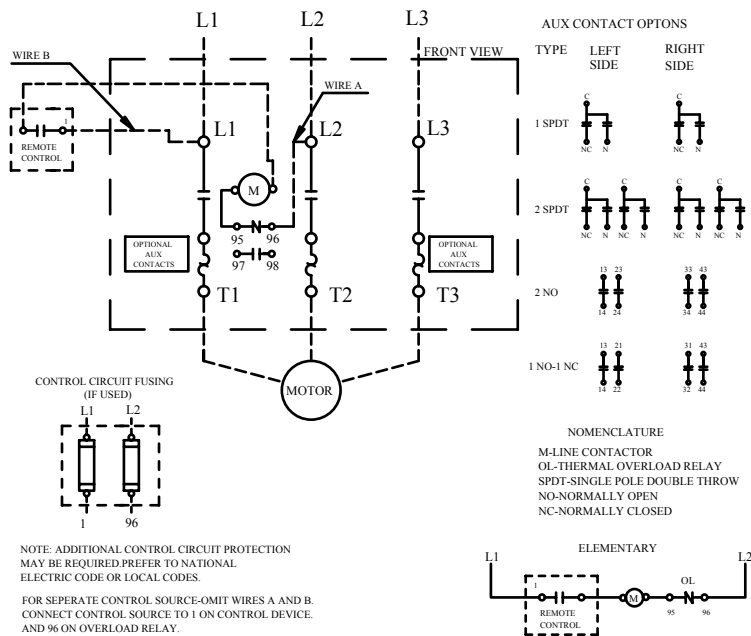

Overload Relays

Contactor	Catalog No.		Current Range (A)
	Class 10	Class 20	
CR453AB, AC, AD	RT1B	RT12B	0.16-0.26
	RT1C	RT12C	0.25-0.41
	RT1D	RT12D	0.4-0.65
	RT1F	RT12F	0.65-1.1
	RT1G	RT12G	1.0-1.5
	RT1H	RT12H	1.3-1.9
	RT1J	RT12J	1.8-2.7
	RT1K	RT12K	2.5-4.1
	RT1L	RT12L	4.0-6.3
	RT1M	RT12M	5.5-8.5
	RT1N	RT12N	8-12
	RT1P	RT12P	10-16
	RT1S	RT12S	14.5-18
RT1T	RT12T	17.5-22	
RT1U	RT12U	21-26	
CR453AC, AD	RT1V	RT12V	25-32
CR453AD	RT1W	RT12W	30-40

For further technical details on overload relays, refer to installation instructions GEH-6237A.

Installation

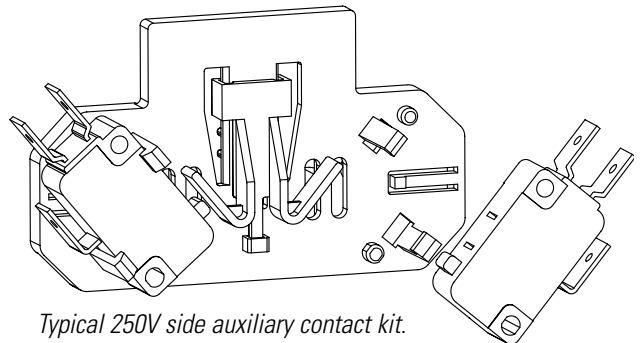

Accessory Kit Installation

Accessories

Accessory	Contacts	CR453A Accessories (with quick connects on side-mount accessories)	Standard C-2000 accessories
600V side-mount aux. contact block	1NO-1NC	CR453XC611	BCLL11
	2NO	CR453XC620	BCLL20
250V side-mount aux. contact block	1 SPDT	CR453XC211	—
	2 SPDT	CR453XC222	—
600V front-mount aux. contact block	1NO	BCLF10	BCLF10
	1NC	BCLF01	BCLF01
Mechanical interlock, side-mount	2NC	CR453XM602	BEL02

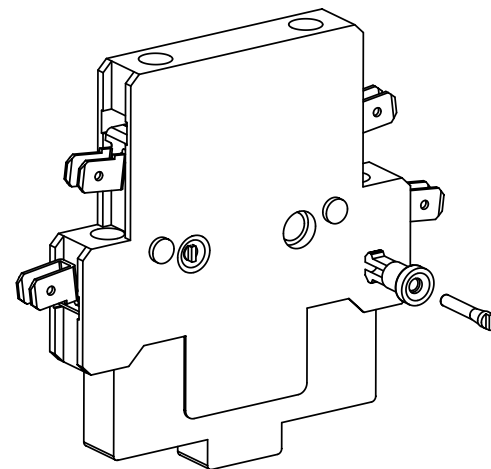

Front-Mount Auxiliary Contacts

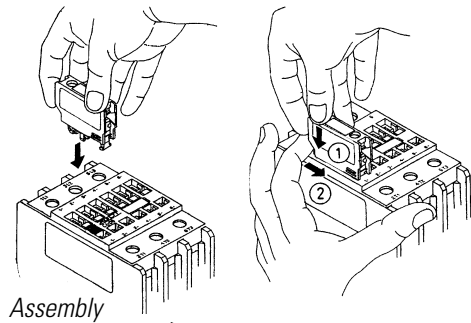

Assembly

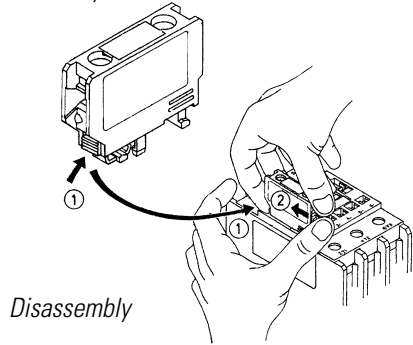

Disassembly

Overload Relays

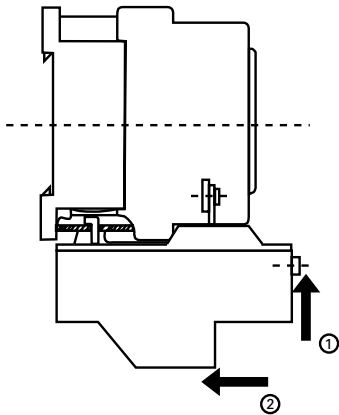

Side-Mount Auxiliary Contacts

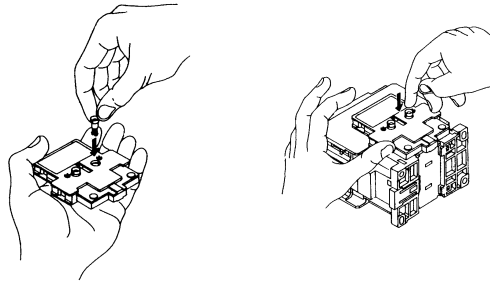

2-Speed Controllers

Mechanical interlock

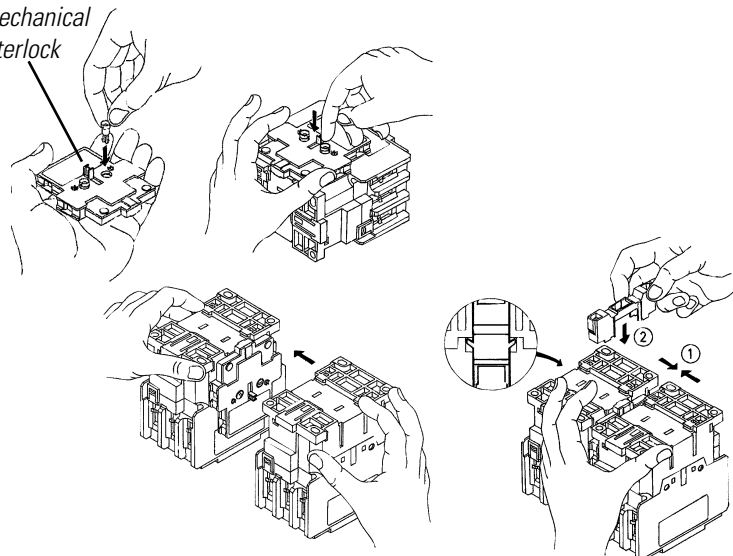

These instructions do not purport to cover all details or variations in equipment nor to provide for every possible contingency to be met in connection with installation, operation or maintenance. Should particular problems arise which are not covered sufficiently for the Purchaser's purposes the matter should be referred to the nearest GE Industrial Systems sales office.



GE Industrial Systems

General Electric Company
41 Woodford Avenue, Plainville, CT 06062
www.GEindustrial.com

© 2001 General Electric Company