



Record Plus™

Molded Case Circuit Breaker

Accessories

Rotary Handle Operator, Type THCH45.

Congratulations and thank you for choosing the **Record Plus™** family of circuit breakers and Rotary Handle THCH45 Operator accessory kit for FC100 circuit breaker series in NEMA 4 and 4X enclosures.

Record Plus™ circuit breakers are designed with a full line of integrated accessories. All units use the latest integrated module circuit breaker technology to allow flexibility in applications and maximizing the product utilization and capabilities.

All **Record Plus™** circuit breakers are listed by Underwriters Laboratories to the UL489 standard and the CSA Standard C22.2, No. 5. These circuit breakers are certified to EN 60947-2.

These accessories are also for use with our MAG-BREAK® instantaneous trip-only circuit breakers, which meet the same standards and are UL-recognized components for use in motor applications. They can also be used with our molded case switches, which are listed per Underwriters Laboratories to the UL489 standard.

Record Plus™ circuit breakers and their accessories are designed and manufactured to exceed our global customers' high standards for reliability and quality.

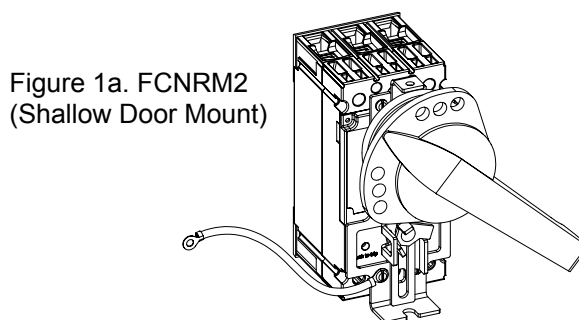

Figure 1a. FCNRM2
(Shallow Door Mount)

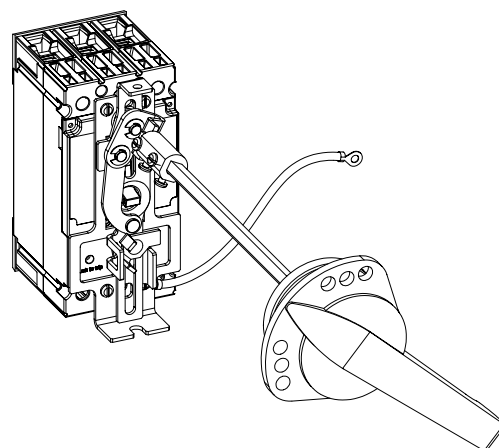

Figure 1b. FCNRM4
(Extended Shaft Door Mount)

Figure 1. FCNRM2 & FCNRM4 with THCH45 Handle mounted on **Record Plus™** FC100 Circuit Breaker.



Warning: DANGER of Electrical shock or injury. Ensure ALL electrical power supplies are OFF before installing or removing any devices. The breaker, trip unit or accessories **MUST ONLY** be installed and serviced by **QUALIFIED** personnel, see NEMA publication AB4.

Avertissement: Danger contre les risques d'électrocutions. S'assurer avant TOUTES manipulations du disjoncteur que les différentes sources d'alimentation sont en position OFF. Les disjoncteurs, unités de protection, ou accessoires doivent être installés par des personnes qualifiées et habilitées. Lire NEMA publication AB4.



CAUTION: This product is NOT suitable for use in equipment not specifically design to accept it. Contact the equipment manufacturer for possible equipment modifications.

ATTENTION: Cet appareil nedeoit pas etre employe dans un equipement non specialement adapte a cet effet. Contactez le constructeur concernant les possibles modifications a apporter a l'equipement.

Product Description

These instructions describe the installation procedure for the Rotary Handle THCH45 operator accessory on **Record Plus™** circuit breakers, as shown in Figures 1a & 1b.

THCH45 operator is available in two variants:

- FCNRM2 provides the necessary parts for direct mounting of the handle on the breaker mechanism through the enclosure door, with a box depth of 5.0 inches (127 mm), as shown in Figure 1a. Maintain the dimension “H” [4.69 inches (119.18)] as shown in Figure 9.
- FCNRM4 is for mounting the handle and operator in enclosures with variable depth, as shown in Figure 1b. Maintain the dimension “H” [Min 7.25 inches (184.0 mm) and Max 15.0 inches (381.0 mm)] as shown in Figure 10.

Step 1 - Unpack and Inspect.

Unpack the rotary handle operating mechanism kit and inspect the parts for any shipping damage. Verify that all parts are supplied, as listed in Table 1. The parts are illustrated in Figure 2.

Note that the numbers in brackets in the following figures and installation instructions refer to the item numbers in Table 1.

Item	Description	Qty
1	Screw, #8-32 x 2.81"	4
2	Base-crank assembly (Direct Mount)	1
3	Grounding Wire	1
4	Screw, #8-32 x 0.312"	4
5	Base-crank assembly (Door Mount)	1
6	Coupler	1
7	Screw, #8-32 x 0.312"	4
8	Handle Arm	1
9	THCH45 Handle Kit	1

Table 1. List of parts in the FC100 THCH45 operator kit.

*Note: Item 9 should be ordered separately.

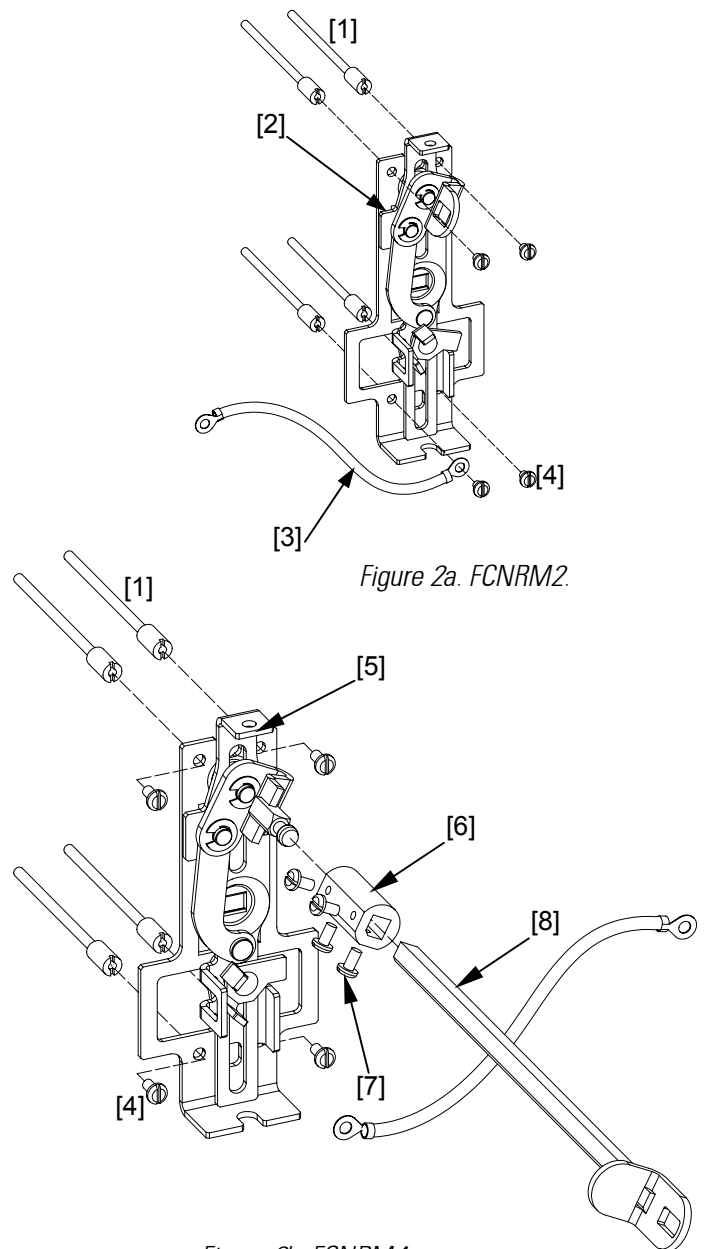

Figure 2b. FCNRM4.

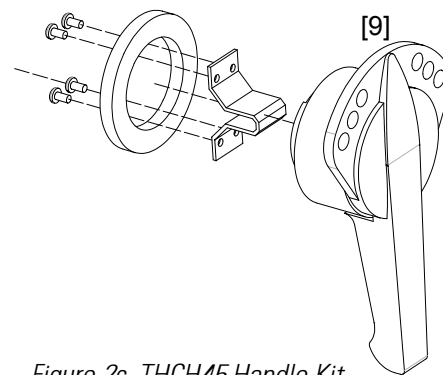

Figure 2c. THCH45 Handle Kit.

Figure 2. Parts supplied with the FC100 THCH45 Operator kits.

Step 2 – Install the Breaker Operating Mechanism.

1. Move the breaker handle to the OFF position.
2. Mount the breaker to the enclosure with # 8-32 x 2.81" screws [1], as illustrated in Figure 3. Tighten the screws to 16- 20 in-lb. Complete the installation of the circuit breaker according to installation instructions DEH40463.
3. **FCNRM2 Direct Mounting -**
(Refer Figure 9 for outline views of completed installations with dimensions).
 - a. Place the base-crank assembly [2] on the breaker, as illustrated in Figure 4.
 - b. Insert the four #8-32 x 0.312" screws [4] through the mounting holes in the base and into the heads of the breaker mounting screws [1], with the grounding wire [3] attached to one of the screws.
 - c. Tighten the screws to 16 - 20 in-lb. Secure the other end of the grounding wire to a suitable ground location.
4. **FCNRM4 Door Mounting -**
(Refer Figure 10 for outline views of completed installations with dimensions).
 - a. Place the base-crank assembly [5] on the breaker, as illustrated in Figure 5.
 - b. Place the coupler (6) on to the crank in the base asm (5) and fasten by screw, #8-32 x 0.312" (7), as illustrated in Figure 6. Tighten the screws to 16- 20 in-lb
 - c. Measure the distance from the breaker-mounting surface to the handle-mounting surface, H, as shown in figures 7 & 10.
 - d. Cut the handle arm [8] to the length L given by
$$L = H - 125.0 \text{ mm (4.92 in.)},$$
as illustrated in Figure 8.
 - e. Attach the handle arm [8] to the coupler [6] with two #8-32 x 0.312" screws [7], as illustrated in Figure 6. Tighten the screws to 16 - 20 in-lb.



Figure 3. Mounting the breaker in the enclosure.

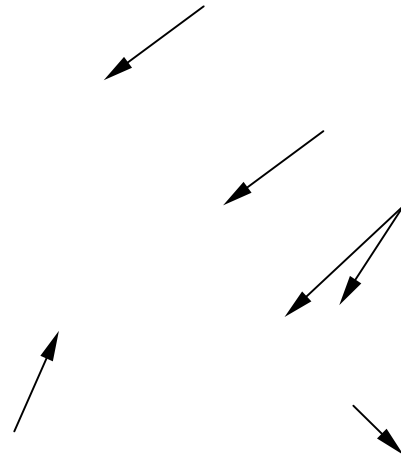

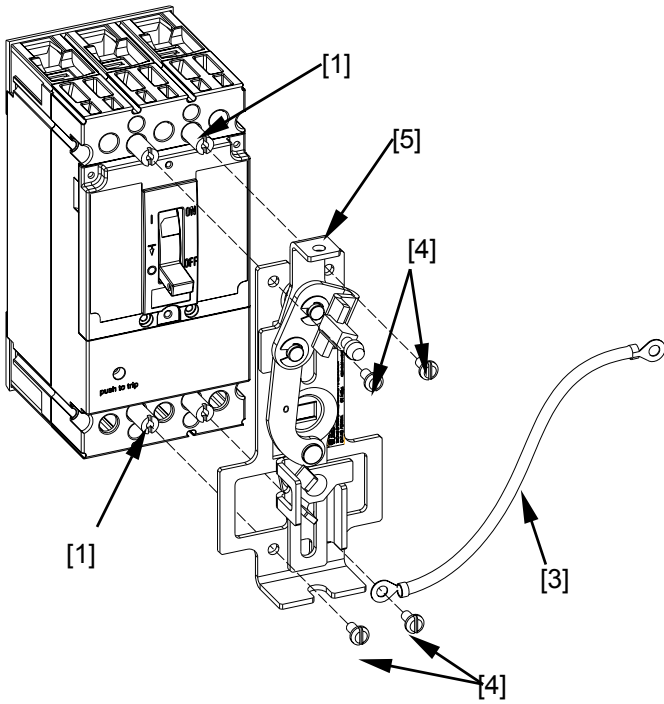

Figure 5. Mounting the FCNRM4 assembly onto the breaker.

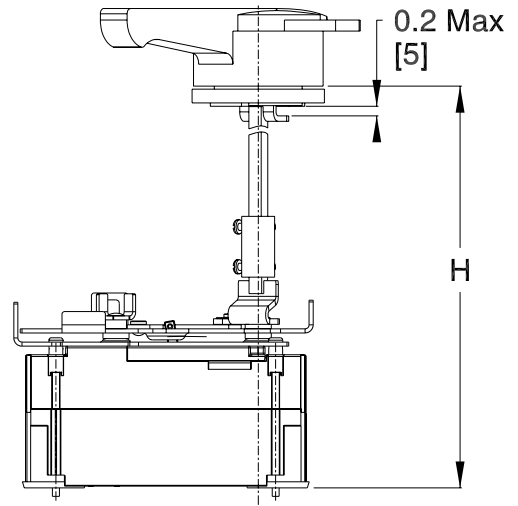

Figure 7. Mounting the Breaker in the Enclosure.

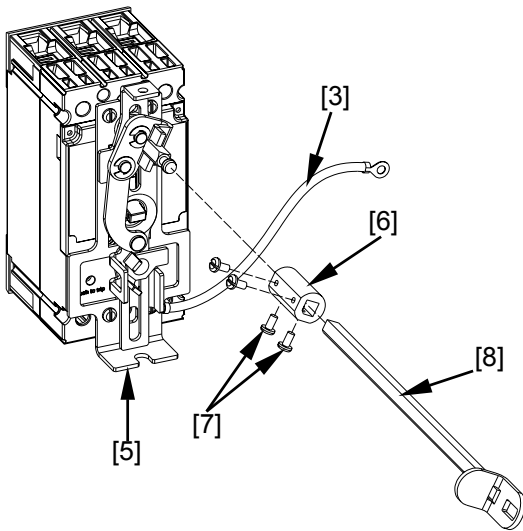

Figure 6. Installing the extension shaft and coupler on to FCNRM4 assembly.

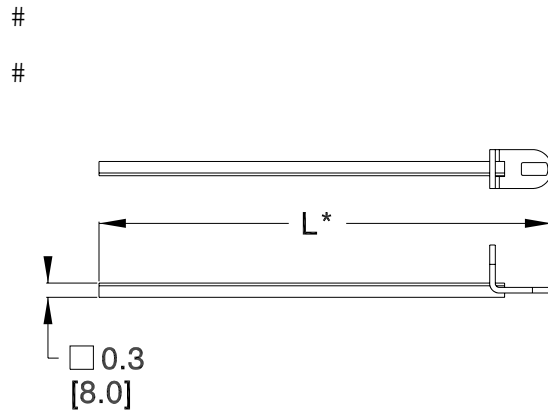

Figure 8. Cutting the Handle arm to the proper length.

Step 3 – Operation

Breaker operation with the rotary handle is as follows:

- Close the enclosure door in **“OFF”** position of breaker.
- To close the breaker, rotate the rotary handle clockwise from the OFF position to ON.
- To open the breaker, rotate the handle counterclockwise from ON to OFF.
- The enclosure door cannot be opened when the breaker is ON.
- Open the enclosure door in **“OFF”** position of breaker only.

Figures 9 and 10 are outline views of completed installations with dimensions.

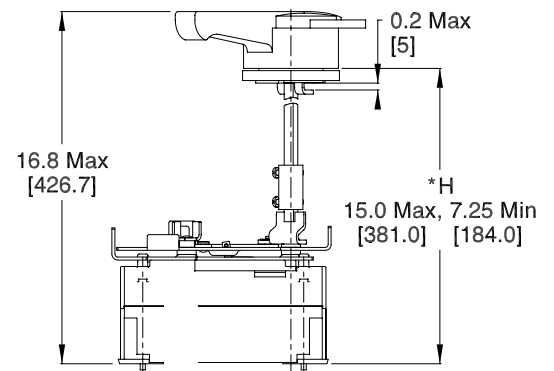
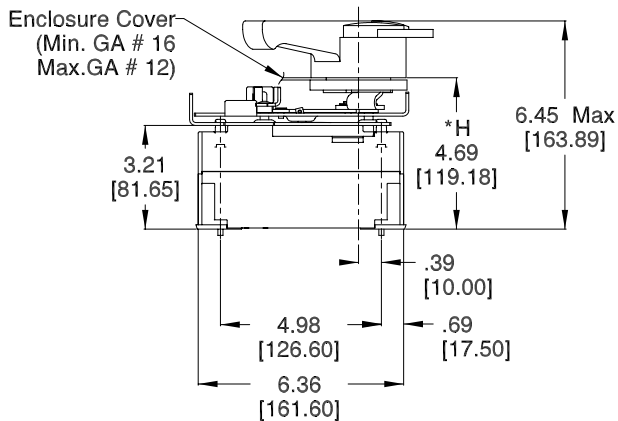
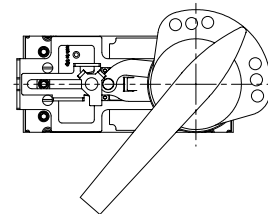
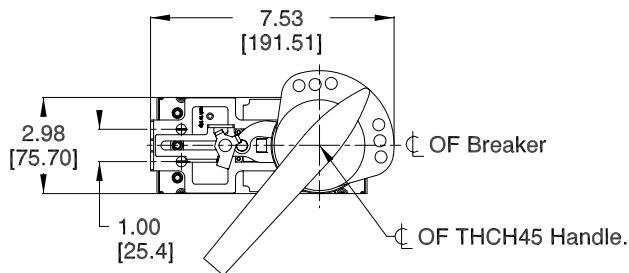

Figure 9. Outline View of completed FCNRM2 installation.

Figure 10. Outline View of completed FCNRM4 installation.

Locking the Rotary Handle Assembly

Push the slider down to **"OFF"** position of breaker and insert the padlock shaft 0.2 in. (5 mm) to 0.315 in. (8 mm) into the slot in the padlock lever, to prevent closing of the breaker during maintenance, illustrated in Figure 11.

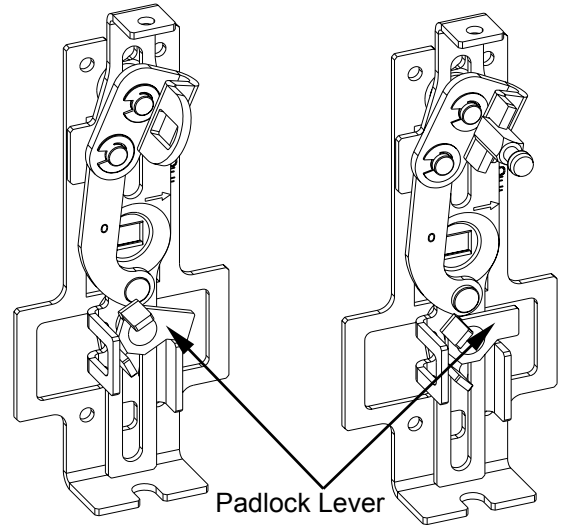

Figure 11. Locking the breaker operating mechanism during emergency.

These instructions do not cover all details or variations in equipment nor do they provide for every possible contingency that may be met in connection with installation, operation, or maintenance. Should further information be desired or should particular problems arise that are not covered sufficiently for the purchaser's purposes, the matter should be referred to the GE Company. The circuit breaker is a sealed unit that contains no user-serviceable parts. Tampering with the seal will void the warranty.



GE Consumer & Industrial

General Electric Company
41 Woodford Ave., Plainville, CT 06062
www.geindustrial.com