



The Switches are “change over switches” with NO, NC & Com terminals. (Form C Contact).

**DEH-41403 Installation Instructions**

**Accessories**

**Carriage Position Switch Kit**

**Introduction**

**Carriage Position Switch Kit:**

Carriage position switch indicates position status of a draw out circuit breaker. The Carriage Position Switch comes in four options:

- 1NO/1NC: one switch indicating Disconnected, Test, or Connected position
- 2NO/2NC: two switches indicating Disconnected, Test, or Connected position
- 6NO/6NC: six switches indicating Connected position
- 2NO/2NC indicating Test position, 4NO/4NC indicating Connected position



**WARNING:** Before installing any accessories, turn the breaker OFF, disconnect it from all voltage sources, and discharge the closing springs.



**AVERTISSEMENT:** Avant d’installer tout accessoire, mettre le disjoncteur en position OFF, le déconnecter de toute tension d’alimentation, et décharger les ressorts d’armement

Use the following procedure to install the Position Switch Kit accessory into the circuit breaker.

1. Verify that the rating and the catalogue on the Position Switch Kit identification plate matches the voltage rating required for the application, as listed in Table 1
2. Before installing ensure the main power sources are disconnected and no power to the breaker main terminals
3. Rack out and remove the Breaker from Cassette if it is installed
4. Insert the carriage position switch wires from the opening from the inside of the cassette and pull out as shown in Fig. 1

**Electrical characteristics Carriage Position Switch Contacts**

**Table 1. Ratings.**

AC Ratings		DC Ratings	
Voltage	Amps	Voltage	Amps
120V	10A	125V	0.5A
250V	10A	250V	0.25A

Contacts are Power Rated

**Table2. Cat No.**

GCPS1R	1 NO/1 NC per position
GCPS2R	2 NO/2 NC per position
GCPS3R	6 NO/6 NC for Connected position
GCPS5R	2 NO/2 NC for Test position, 4 NO/4 NC for Connected position



**Figure 1. Wire insertion.**

- Slide & insert the switch assembly to engage the cassette side sheet in the slot and push towards the front as shown in Fig. 2



**Figure 2. CPS assembly**

- Push the complete assembly to come out side of the cassette and the snap feature engages with the cassette side sheet as shown in Fig.3.



**Figure 3. CPS assembly**

- Ensure the assembly is firmly fitted and locked down by the four snaps features.
- Check functionality of carriage position switch by racking in the breaker and racking out the breaker and confirming changeover of switch as specified in tables 3 - 6.
- Complete the wiring with the equipment.

**Table 3: Switch terminals for cat GCPS1R**

Breaker Position	Continuity between terminals
Disconnected	D11-D14
Test	D31-D34
Connected	D51-D54

**Table 4: Switch terminals for cat GCPS2R**

Breaker Position	Continuity between terminals
Disconnected	D11-D14 & D21-D24
Test	D31-D34 & D41-D44
Connected	D51-D54 & D61-D64

**Table 5: Switch terminals for cat GCPS3R**

Breaker Position	Continuity between terminals
Connected	D11-D14, D21-D24, D31-D34, D41-D44, D51-D54, & D61-D64

**Table 6: Switch terminals for cat GCPS5R**

Breaker Position	Continuity between terminals
Test	D31-D34 & D41-D44
Connected	D11-D14, D21-D24, D51-D54 & D61-D64

**Reference:**

Carriage Position Switch Kit Connection Scheme (GCPS1R or GCPS2R):

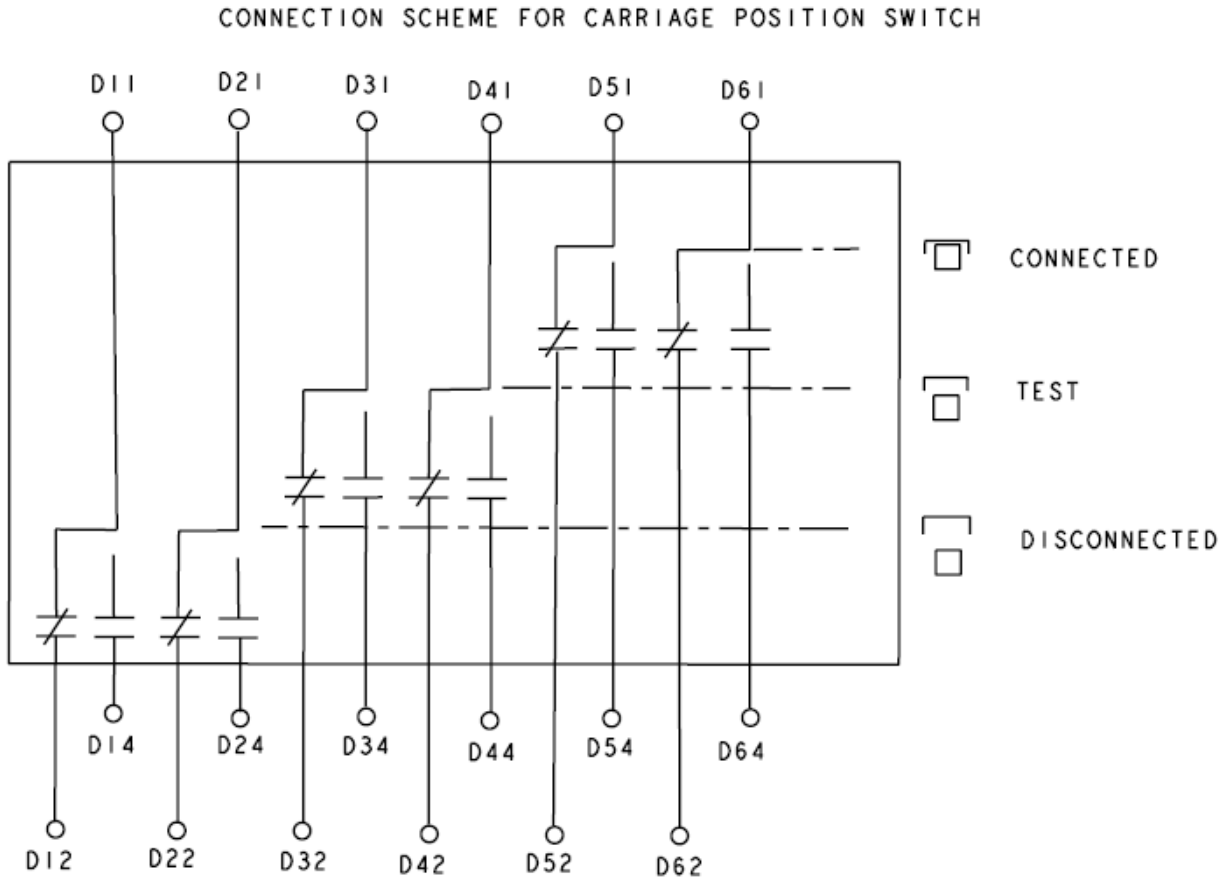

Carriage Position Switch Kit Connection Scheme (GCPS3R):

CONNECTION SCHEME FOR CARRIAGE POSITION SWITCH

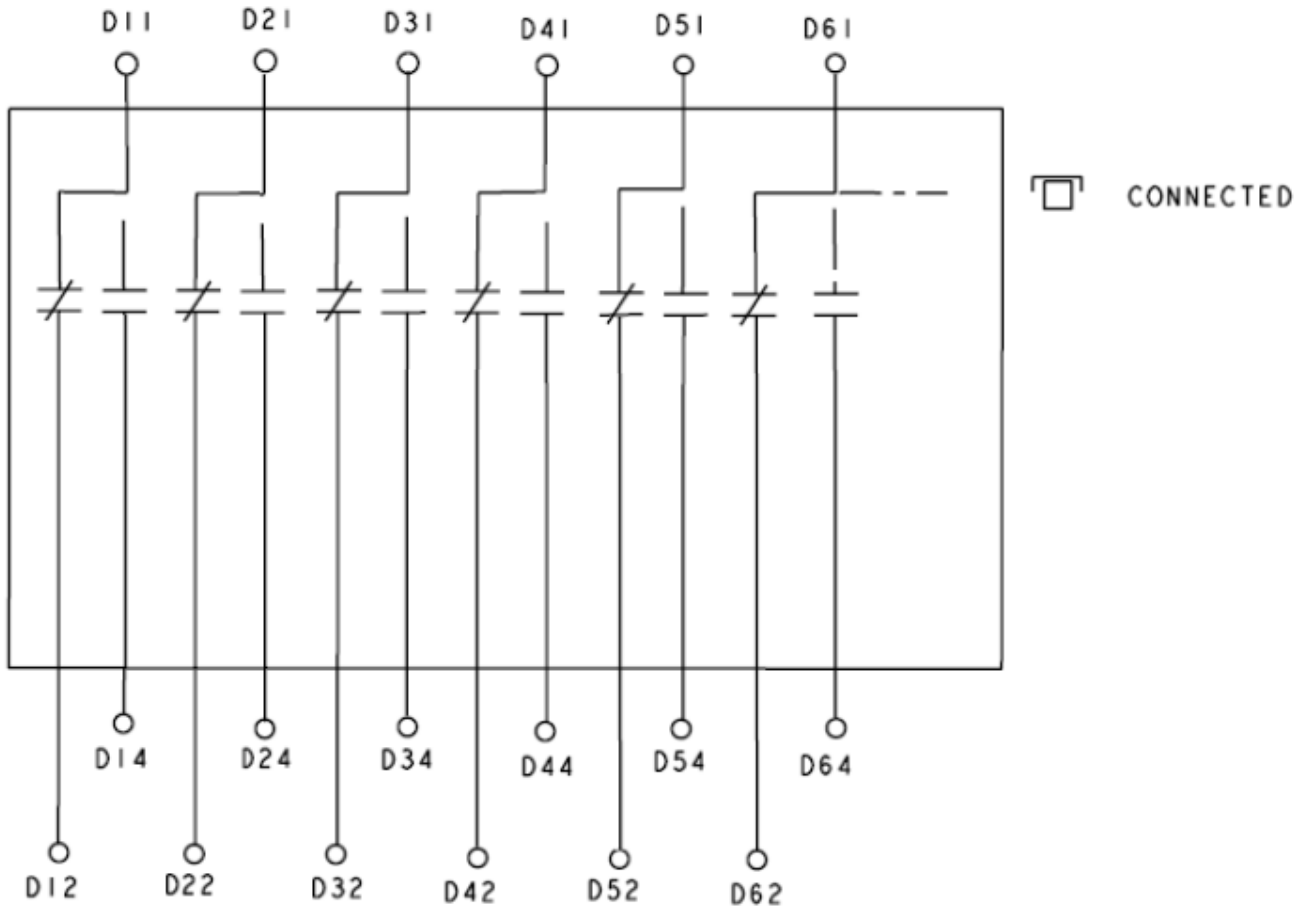

Carriage Position Switch Kit Connection Scheme (GCPS5R):

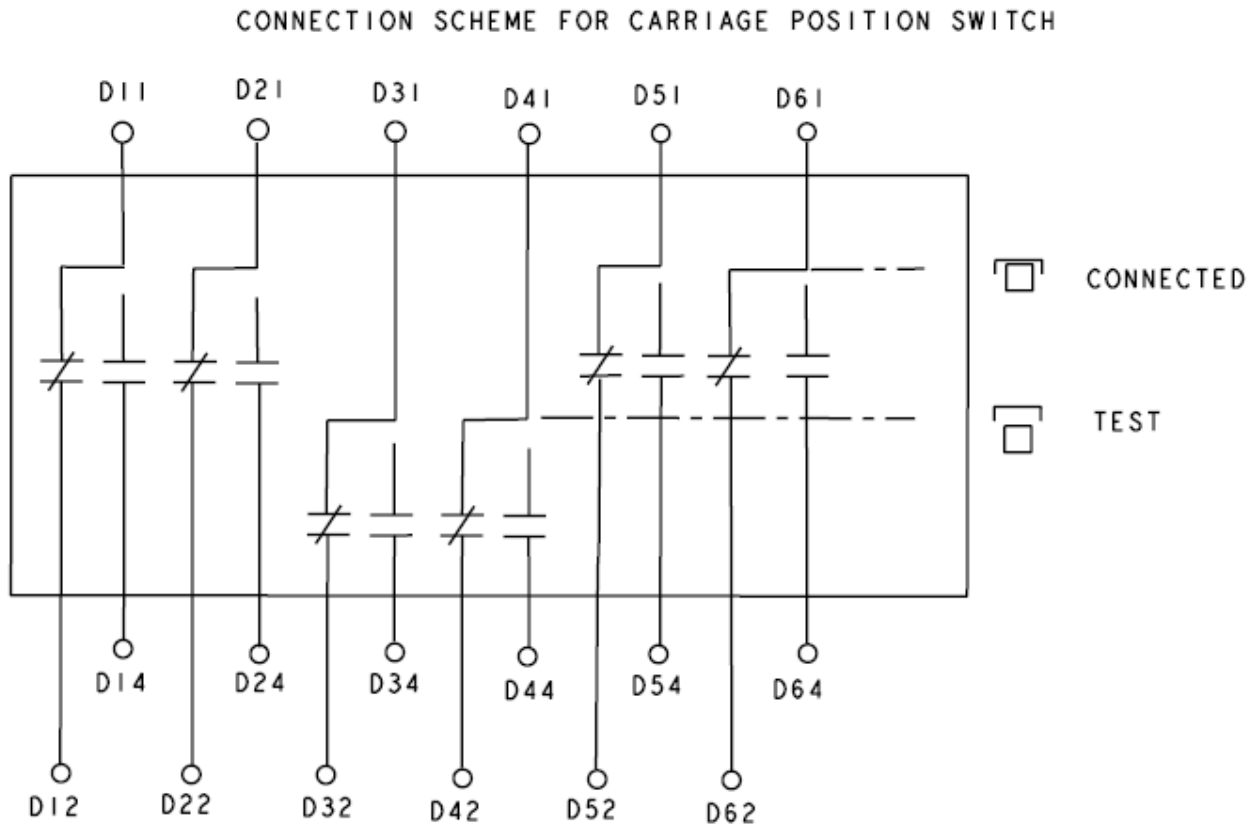

These instructions do not purport to cover all details or variations in equipment nor, to provide contingency to be met in connection with installation, operation, or maintenance. Should further information be desired, or should particular problems arise which are not covered sufficiently for the purchaser's purposes, the matter should be referred to GE.

GE  
 41 Woodford Ave, Plainville, CT 06062  
 www.geelectrical.com

© 2009 General Electric Company

