



DEH-41410 Installation Instructions

EntelliGuard® G Circuit Breaker Accessories

Introduction

Undervoltage Release:

A device designed to open the breaker contacts and to prevent the breaker from closing when in a 'No volt' condition. On a de-energization the Undervoltage release activates the circuit breaker mechanism and ensures a rapid disconnection of the main contacts and the device prevents the Power Circuit Breaker from closing. The EntelliGuard G™ Undervoltage release is designed to react within a pre-defined Voltage band, only reacting when the voltage supply drops below the limits of this band. To prevent nuisance tripping due to short power interruptions or 'Brown Outs' the device has a built in delay of 50 Milliseconds when Voltage is at or below 50% of rated Voltage. Two under voltage Releases can be mounted in each Power Circuit Breaker.



Table 1.

Catalog No	DC Voltage	AC Voltage
GUVT024DR	24V	
GUVT030DR	30V	
GUVT048R	48V	48V
GUVT060DR	60-72V	
GUVT120R	110-130V	120-130V
GUVT208AR		208V
GUVT240R	220-240V	220-240V
GUVT277R	250V	250-277V

Undervoltage Release



WARNING: Before installing any accessories, turn the breaker OFF, disconnect it from all voltage sources, and discharge the closing springs.



AVERTISSEMENT: Avant d'installer tout accessoire, mettre le disjoncteur en position OFF, le déconnecter de toute tension d'alimentation, et décharger les ressorts d'armement

For an External Time Delay Module (1-3 second delay) refer to Pub DEH-41406

- **Inrush Power: 350VA**
- **Steady state : 40VA**

Use the following procedure to install the Undervoltage Device accessory into the circuit breaker.

1. Verify that the rating on the Undervoltage Device identification plate matches the voltage rating required for the application, as listed in Table 1.
2. Turn the breaker off and discharge the closing springs by depressing the OFF and ON buttons in the sequence OFF-ON-OFF. Verify that the breaker OFF-ON indicator shows OFF on a green background and that the charge indicator shows DISCHARGE on a white background. If installing in a draw-out type breaker remove breaker from adaptor (cassette) before continuing.
3. Loosen the 6 screws on front cover (fascia) using a posidrive screw driver as shown in Fig 1.B Rotate the charging handle down and slide the front cover over the handle to remove the front cover as shown in Fig. 1.C.

hooks into the mechanism top support plate as shown in the Fig. 3.



Figure 1. (A) Front Cover (B) Screw Removal (C) Handle Rotation

4. This accessory is mounted on the mechanism. Top plate at 2nd or 4th location as shown in Fig. 2.



Figure 2.

5. Tilt the coil forward and engage the front

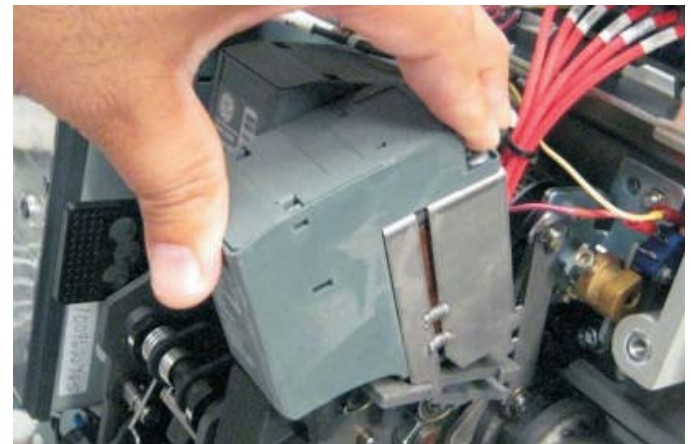

Figure 3. Insert top plate

6. Tilt the device backwards until the rear hooks engage in the slots on the mechanism top support plate as shown in the Fig. 4



Figure 4. Snap on.

7. After installing the UV on the mechanism top plate, connect the input wire assembly plug to the A7/A8 if installed (2nd location) or A12/A13 (4th location) marked on the secondary disconnect as shown in Fig. 5.



Figure 5. Wire assembly

8. Ensure that the plug in connection is firm and that the plug is inserted into the correct terminals.

9. To reinstall the cover, rotate the charging handle down and slide the front cover over the handle to assemble the front cover to housing as shown in Fig. 6.



10. Ensure the fascia is aligned properly with the trip unit and the pad lock features of the breaker.

11. Fasten the 6 mounting screws of fascia with the housing using a pozidrive screwdriver. Apply torque of 6 Nm (4.42 ft-lbs).

Figure 6.

Reference:

Undervoltage Device Connection Scheme:

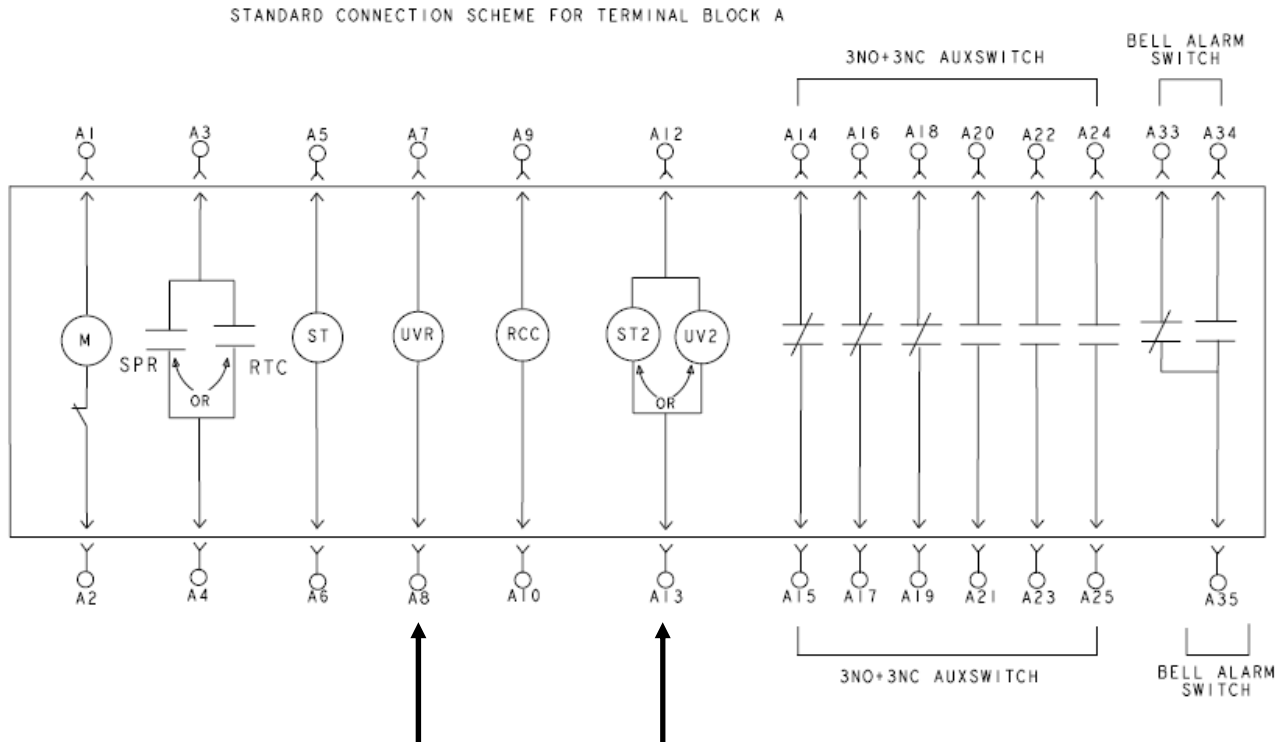

These instructions do not purport to cover all details or variations in equipment nor, to provide contingency to be met in connection with installation, operation, or maintenance. Should further information be desired, or should particular problems arise which are not covered sufficiently for the purchaser's purposes, the matter should be referred to GE.

GE
41 Woodford Ave, Plainville, CT 06062
www.geelectrical.com

© 2009 General Electric Company



DEH-41410 R1 (03/09)