



DEH-41411 Installation Instructions

EntelliGuard® G Circuit Breaker Accessories

Shunt Trip (Extended Range)

Introduction

Shunt Trip (Extended Range):

A device designed to switch the Power Circuit Breaker OFF remotely. When energized a Shunt Release instantaneously activates the circuit breaker mechanism ensuring a rapid disconnection of the main contacts.

Two Shunt trips can be mounted in each Power Circuit Breaker. The devices are available as factory mounted components or as field mountable devices. It is an easy-to-fit, clip-on unit, with simple plug-in connectors to the Secondary Disconnect Block.



Table 1. Catalog Numbers and Ratings

Catalog No.	DC Voltage	AC Voltage	Rating*
GSTG024D	24V		Continuous
GSST024D	24V		Momentary
GSTG048	48V	48V	Continuous
GSTG072	70-72V		Continuous
GSTG120	110-125V	120-125V	Continuous
GSST120	110-130V	110-130V	Momentary
GSTG208A		208V	Continuous
GSTG240	220V	240V	Continuous
GSST240	220-240V	220-240V	Momentary
GSTG250D	250V		Continuous

* Momentary Rated shunt trip requires wiring one or more NO (Normally Open) breaker aux contact(s) in series with the accessory to avoid coil damage.

WARNING: Before installing any accessories, turn the breaker OFF, disconnect it from all voltage sources, and discharge the closing springs.

AVERTISSEMENT: Avant d'installer tout accessoire, mettre le disjoncteur en position OFF, le déconnecter de toute tension d'alimentation, et décharger les ressorts d'armement

- **Inrush Power: 480VA**
- **Steady state : 50VA**

Use the following procedure to install the Shunt Trip accessory into the circuit breaker.

1. Verify that the rating on the Shunt Trip Mechanism identification plate matches the voltage rating required for the application, as listed in Table 1.
2. Turn the breaker off and discharge the closing springs by depressing the OFF and ON buttons in the sequence OFF-ON-OFF. Verify that the breaker OFF-ON indicator shows OFF on a green background and that the charge indicator shows DISCHARGE on a white background. If installing in a draw-out type breaker remove breaker from adaptor (cassette) before continuing.
3. Loosen the 6 screws on front cover (fascia) using a posidrive screw driver as shown in Fig 1.B Rotate the charging handle down and slide the front cover over the handle to remove the front cover as shown in Fig. 1.C .



Figure 1. (A) Front Cover (B) Screw Removal (C) Handle Rotation

4. This accessory is mounted on the mechanism top plate at 1st or 4th location as shown in Figure 2.



Figure 2.

5. Tilt the coil forward and engage the front hooks into the mechanism top support plate as shown in Fig. 3. Tilt the device backwards until the

rear hooks engage in the slots on the mechanism top support plate as shown in Fig. 4.



Figure 3. Shunt Trip Inserting



Figure 4. Shunt Trip Assembly

6. After installing the shunt release on the mechanism top plate, connect the input wire assembly plug to the A5/A6 (if installed in the first location) or A12/A13 (if installed in the fourth location) locations marked on the secondary disconnect as shown in Fig. 5.



Figure 5. Wiring.

7. Ensure that the plug in connection is firm and that the plug is inserted into the correct terminals.

8. To reinstall the breaker cover rotate the charging handle down and slide the front cover over the handle to assemble the front cover to the housing as shown in Figure 6.

9. Ensure the fascia is aligned properly with the trip unit and the pad lock features of the breaker.



Figure 6.

10. Fasten the 6 mounting screws of the fascia with the housing using a Pozidrive screwdriver. Apply torque of 6Nm (4.42 ft-lbs).

11. When installing a GSST* shunt trip device you must wire one or more Normally Open (NO) breaker auxiliary contact(s) in series with the shunt trip accessory coil. In some cases multiple contacts in series are required to ensure reliable performance.

Application Voltage	Required Aux. Contacts
All AC Ratings, 24VDC	One
120VDC	Two
240VDC	Three

GSST* devices do not require an auxiliary contact.



WARNING: Failure to wire a normally open breaker auxiliary contact in series with the GSST* shunt trip accessory will result in accessory damage.

Reference:

GSTG type Continuously Rated Shunt Trip Connection Scheme

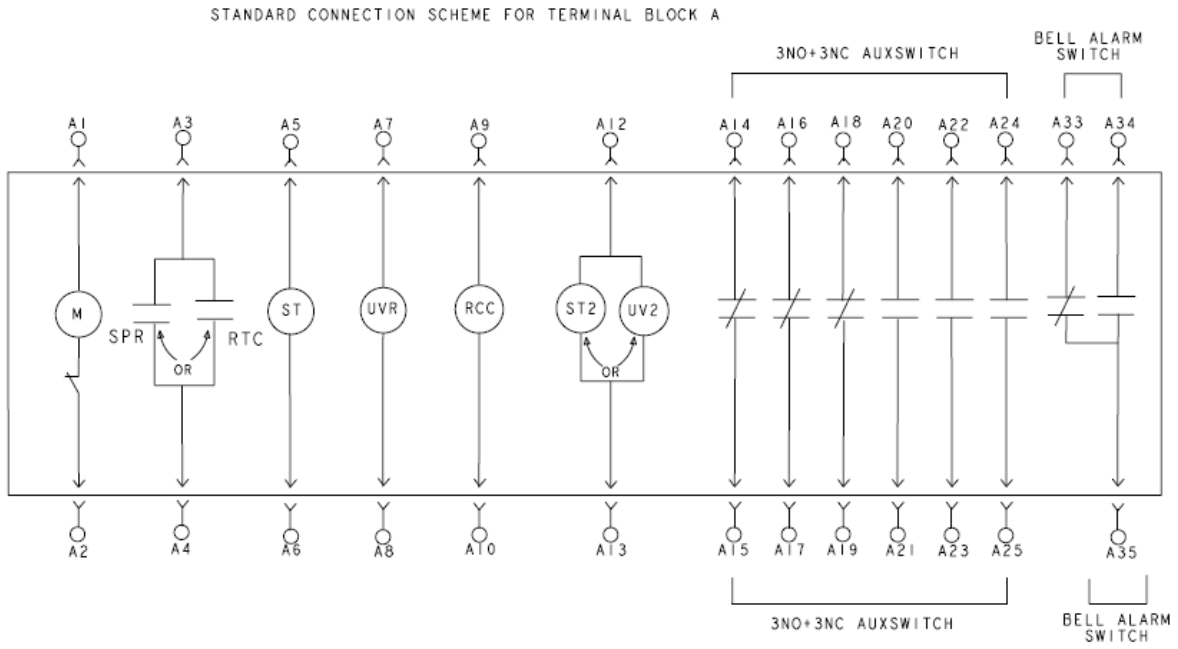

Reference:

GSST type Shunt Trip Connection Scheme with mandatory Breaker Aux contact wiring and optional coil continuity detection circuit. The number of auxiliary contacts wired in series varies by voltage rating.

Application Voltage	Required Aux. Contacts
All AC Ratings, 24VDC	One
120VDC	Two
240VDC	Three

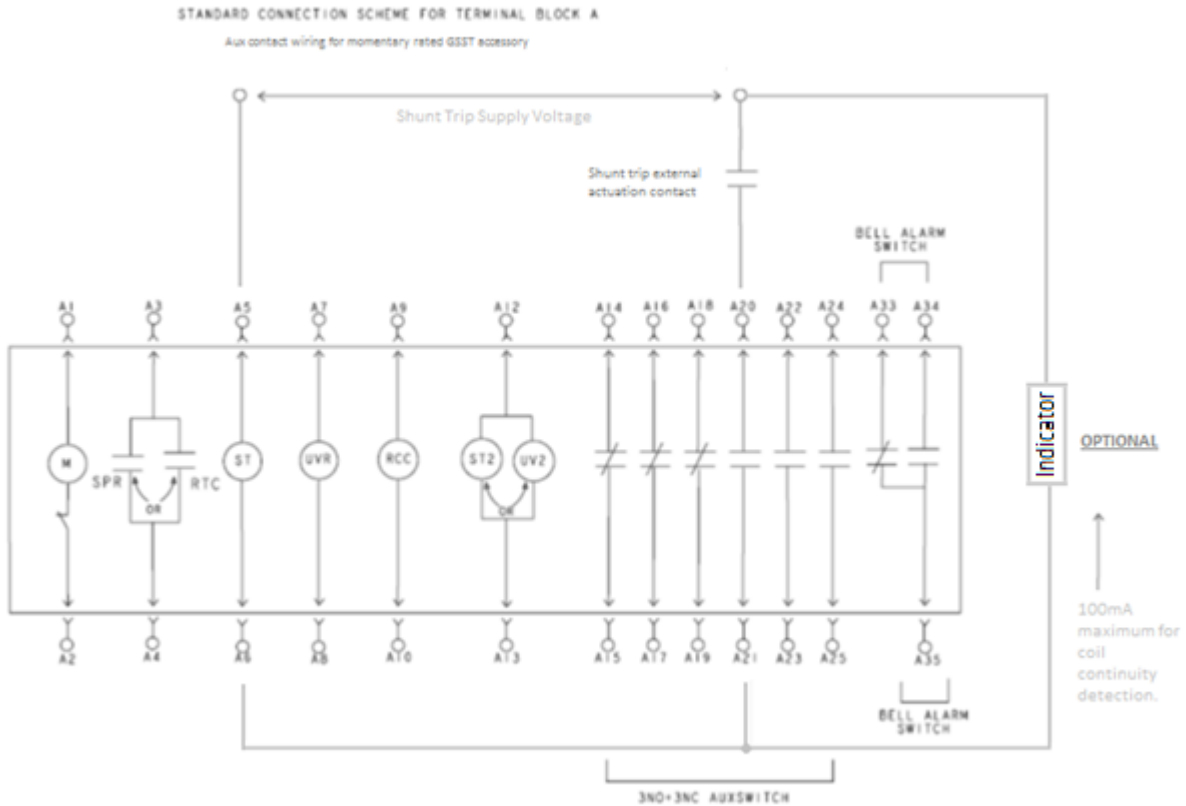

These instructions do not purport to cover all details or variations in equipment nor, to provide contingency to be met in connection with installation, operation, or maintenance. Should further information be desired, or should particular problems arise which are not covered sufficiently for the purchaser's purposes, the matter should be referred to GE.

GE
41 Woodford Ave, Plainville, CT 06062
www.geindustrial.com

© 2019 General Electric Company



DEH-41411 R2 (05/19)