

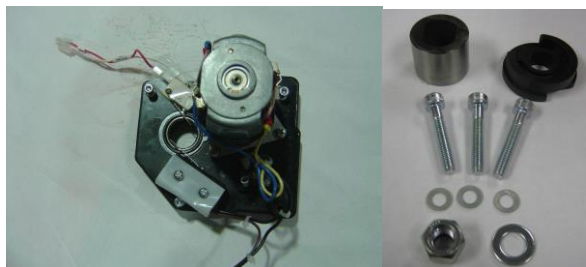

## DEH-41413 Installation Instructions

### Motor Operator

The unique motor/gearbox unit is specially designed to operate with the full range of EntelliGuard G Circuit Breakers. It is easily fitted with three heavy-duty bolts. After a breaker close operation, the unit automatically recharges the spring and makes it ready for immediate open and re-close should the need arise. High speed recharging ensures that the springs are fully charged within approximately three seconds following a release. All electrically operated (EO) ANSI/UL breakers are equipped with "Spring Charged, Power Rated" contacts for status indication.



**Table 1. Motor Catalog and Ratings**

Envelope Size	Catalog #	Voltage Rating
Envelope 1	GM01024D	24/30Vdc
	GM01048D	48 Vdc
	GM01060D	60Vdc
	GM01110D	110/130 Vdc
	GM01250D	250 Vdc
	GM01048A	48 Vac
	GM01120A	120 Vac
	GM01240A	240 Vac
Envelope 2  Envelope 2.5 & Envelope 3	GM01277A	277 Vac
	GM02024D	24 /30 Vdc
	GM02048D	48 Vdc
	GM02060D	60 Vdc
	GM02110D	110/130 Vdc
	GM02250D	250 Vdc
	GM02048A	48 Vac
	GM02120A	120 Vac
	GM02240A	240 Vac
	GM02277A	277 Vac

## EntelliGuard® G Circuit Breaker Accessories

### Motor Operator



**WARNING:** Before installing any accessories, turn the breaker OFF, disconnect it from all voltage sources, and discharge the closing springs.



**AVERTISSEMENT:** Avant d'installer tout accessoire, mettre le disjoncteur en position OFF, le déconnecter de toute tension d'alimentation, et décharger les ressorts d'armement

- Duty Cycle = 2/min
- Spring Charge time = 4s max
- Frame 1 motors: running ~300VA
- Frame 2/3 motors: running ~450VA
- Inrush is 2 to 3 times running VA

Use the following procedure to install the Motor Operator accessory into the circuit breaker.

1. Verify that the rating on the Motor Operator Mechanism identification plate matches the voltage rating required for the application, as listed in Table 1.
2. Check that the package contains all the parts listed in Table 2. If any components are missing, contact the Electrical Distribution Post Sales Service Team at 1-800-843-3742.

**Table 2. Parts List**

Description	Quantity
Motor Operator Assembly	1
Shaft Bearing Sleeve	1
Switch Operating Cam	1
Washer M8	1
Nylock Nut M8	1
Cerrated Belleville Washer M5	3
Hex Socket Head Cap Screw M5X30	3

3. Turn the breaker off and discharge the closing springs by depressing the OFF and ON buttons in the sequence OFF-ON-OFF. Verify that the breaker OFF-ON indicator shows OFF on a green background and that the charge indicator shows DISCHARGE on a white background. If installing in a draw-out type breaker remove breaker from adaptor (cassette) before continuing.

4. Loosen the 6 screws on front cover (fascia) using a pozidrive screw driver as shown in Fig 1.B Rotate the charging handle down and slide the front cover over the handle to remove the front cover as shown in Fig. 1.C



**Figure 1. (A) Front Cover (B) Screw Removal (C) Handle Rotation**

5. Slide the sleeve (coupling bush) on the camshaft as shown in fig 2.



**Figure 2. Assembly of sleeve**

6. Orient the device as shown in Fig. 3, locating the gearbox bearing on to the cam drive shaft, pushing it until flush with the mechanism side plate. If it does not move easily to the flush position, pull the charging handle gently down to ease movement.

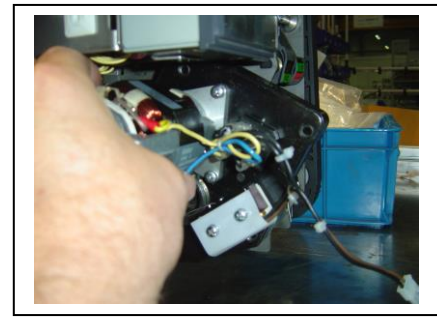

**Figure 3. Motor assembly mounting**

7. Rotate the motor operator to align the 3 mounting holes in the side sheet. Mount the device using three M5 bolts through the holes provided in the gearbox endplate, torque to 7 Nm (5.16 ft-lbs).

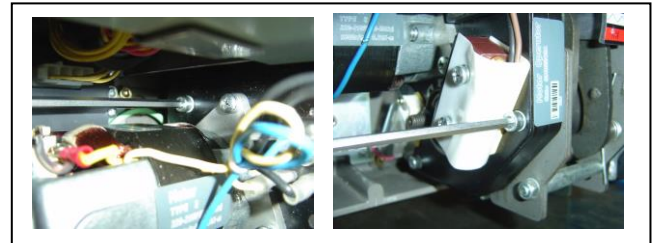

**Figure 4. Assembly of screws**

8. Before installing the cam as shown in fig. 5, fully charge the breaker. (DO NOT CLOSE!) Position the cam with the cutout toward the front of the breaker as shown in fig. 6.

Assemble the cam on the cam drive shaft while pressing the two switch levers as shown in fig. 5.

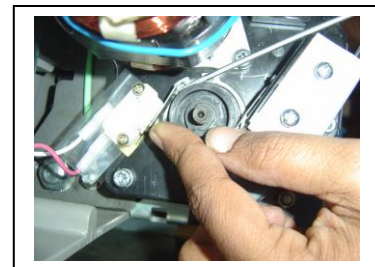
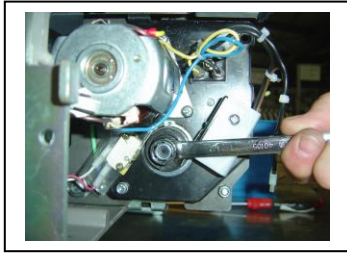

**Figure 5. Assembly of cam**



**Figure 6. Cam Orientation when charged**

9. Assemble the M8 nylock nut at the end of the camshaft and torque to 12 Nm (8.85 ft-lbs) fig .7.



**Figure 7. Assembly of Nut**

10. Manually charge the springs with the charging handle and ensure the motor is assembled properly.

11. Connect the input wire assembly plugs for the motor and the spring charge status indicator switch as shown in fig.8.

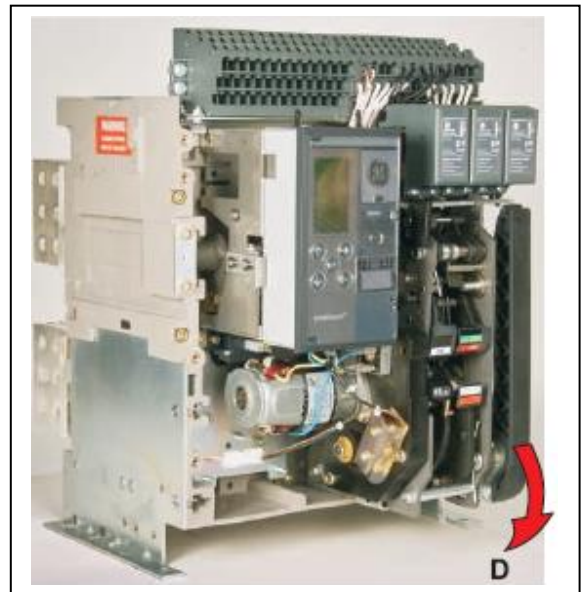

**Figure 8. Assembly of connectors**

12. To reinstall the cover, rotate the charging handle down and slide the front cover over the handle to assemble the front cover to housing as shown in Fig. 9.

13. Ensure the fascia is aligned properly with the trip unit and the pad lock features of the breaker

14. Fasten the 6 mounting screws of fascia with the housing using a pozidrive screwdriver. Apply torque of 6 Nm (4.42 ft-lbs).



**Figure 9.**

**Reference:**  
Secondary Disconnect Wiring Diagram

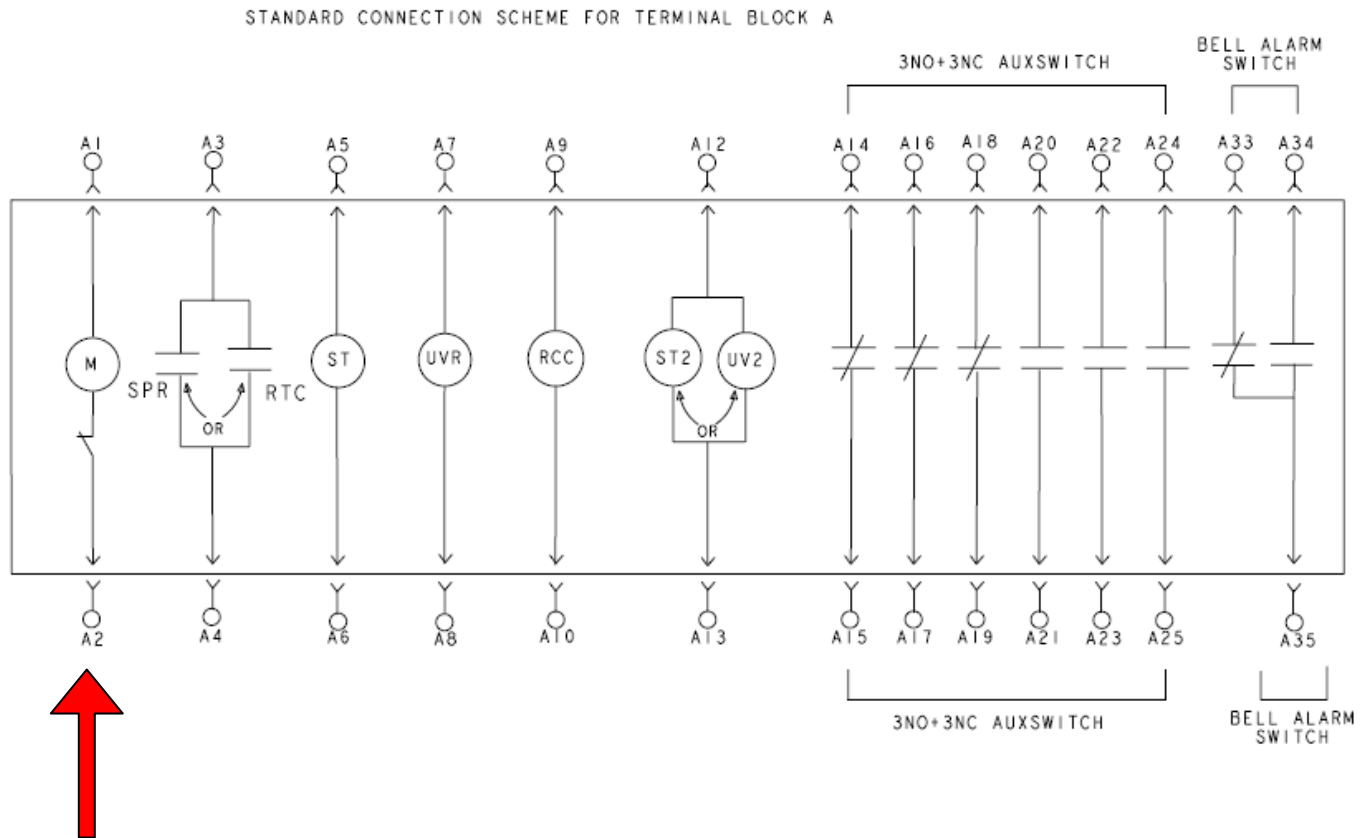

These instructions do not purport to cover all details or variations in equipment nor, to provide contingency to be met in connection with installation, operation, or maintenance. Should further information be desired, or should particular problems arise which are not covered sufficiently for the purchaser's purposes, the matter should be referred to GE.

GE  
41 Woodford Ave, Plainville, CT 06062  
www.geelectrical.com

© 2009 General Electric Company



DEH-41413 R3 (12/15)