

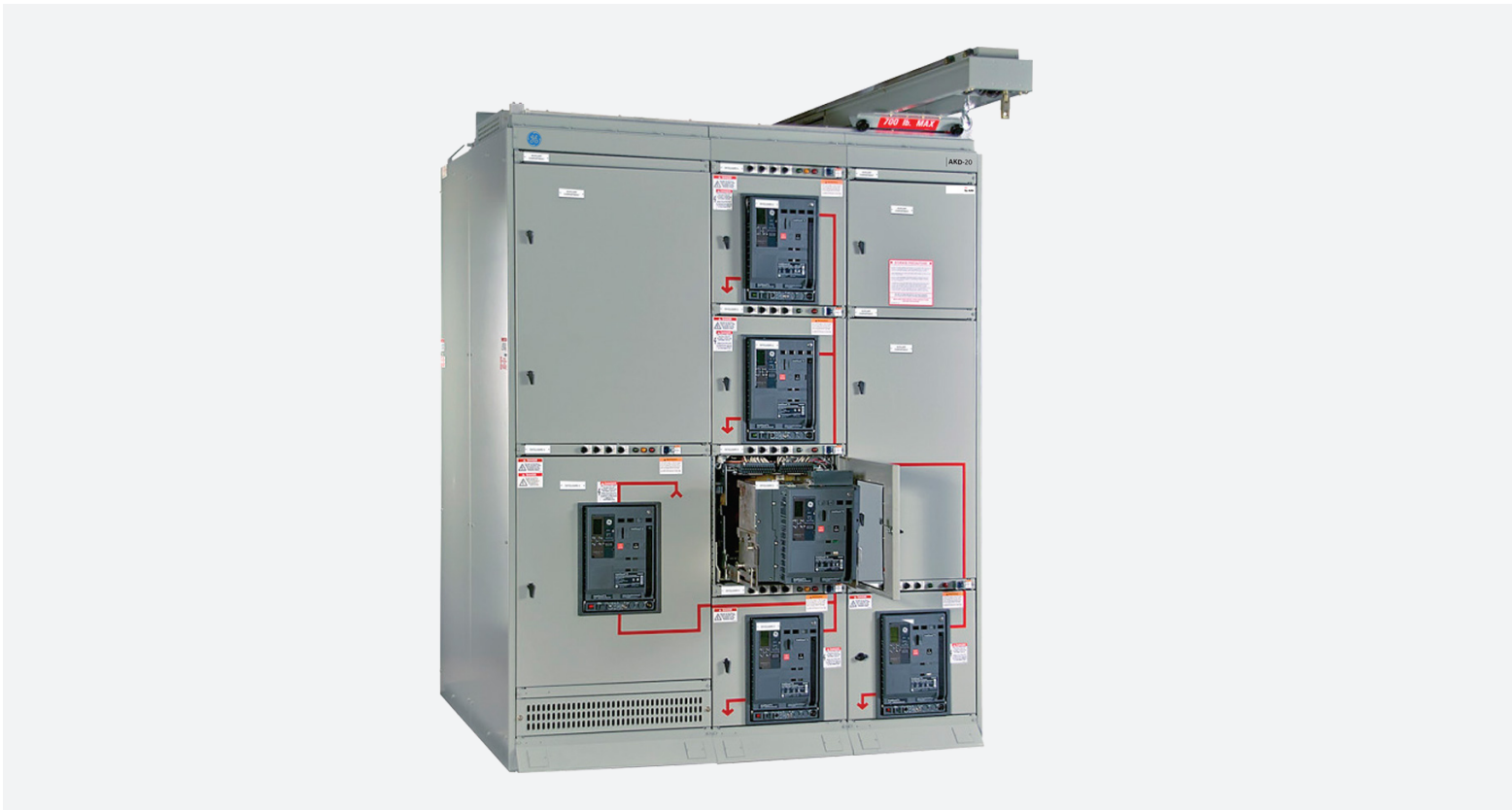

INSTALLATION, OPERATIONS AND MAINTENANCE MANUAL

AKD-20 and Entellisys

Low voltage switchgear



These instructions convey information that pertains to both AKD-20 and Entellisys low voltage switchgear. Information that is applicable only to AKD-20 will be marked as (AKD-20 only) and information that is applicable only to Entellisys will be marked as (Entellisys only). Unless marked otherwise, information provided in this document is applicable to both products.

These instructions do not purport to cover all details or variations in equipment nor to provide for every possible contingency to be met in connection with installation, operation or maintenance. Should further information be desired or should particular problems arise which are not covered sufficiently for the Purchaser's purposes, the matter should be referred to your ABB sales representative. These instructions are intended for use by qualified personnel only.

Table of contents

03–05	Introduction
06–13	Receiving, handling and storage
14–29	Switchgear description
30–49	Equipment installation
50–54	Installing and removing circuit
55–57	Testing and inspection
58–62	Operating the switchgear
63	Energizing the switchgear
64–70	Maintaining the switchgear
71–85	Appendices

1. Introduction

1.1 General information

This manual contains procedures for receiving, handling, storage, equipment installation, operation, and maintenance and service of AKD-20 and Entellisys low voltage switchgear.



Note: The personnel responsible for installing, operating, and servicing this equipment should be thoroughly familiar with the contents of this manual.

Remarque: Le personnel chargé de l'installation, de l'utilisation et de l'entretien de cet équipement doit parfaitement maîtriser le contenu de ce manuel.

Before any installation work is performed, thoroughly read and understand the material in this instruction manual and the drawings furnished with the equipment. The documentation shipped with the equipment includes the Summary, Front View, Elementary Diagram, Connection Diagram and Instruction Book. This material is located in a forward compartment tagged "INSTRUCTIONS IN THIS COMPARTMENT." The documentation provides all of the information necessary for installation of the switchgear. When requesting information from ABB, include the complete data appearing on the equipment nameplate, requisition number, summary number, and elementary diagram number. The nameplate is located in the lower left, front corner of the lineup.

When requesting information concerning any specific item furnished with the switchgear, refer to that item by description, part number, its location within this manual, and any applicable drawing number. Any material external to the equipment, which may be required to meet local codes (such as mats, screens, railings, etc.), is not furnished by ABB.

If there are any questions or requirements not covered in this manual or in the accompanying drawings, please contact your ABB sales representative.

1.2 Instruction book arrangement

Information and procedures in this instruction book are divided as follows:

1. Introduction, gives a brief account of the equipment's function and provides for general information, and applicable data for the equipment and its components.
2. Receiving, Handling and Storage, describes procedures required for receiving and handling the equipment and how to prepare it for short-or long-term storage.
3. Description, describes the AKD-20 and Entellisys low voltage switchgear and its various components. Included are the section enclosure, breaker compartment, circuit breakers, instrument panels and instrument compartments, bus bar arrangement, incoming cable and busway, ground and neutral bus, outdoor equipment, and auxiliary section. This section also explains how the electrical and mechanical components perform their assigned functions.
4. Equipment Installation, provides the information needed prior to installation, site location and foundation requirements, and how to anchor the equipment properly and safely. It also covers installation of peripheral equipment and includes information on electrical connections and mechanical construction.
5. Installing and Removing Circuit Breakers, gives a step-by-step procedure for lifting the breaker from the floor, installing it on draw-out rails, and moving it into the connected position. A further procedure is given to withdraw a breaker, remove it from the draw-out rails, and lower it to the floor. Also included is a description of the rejection system provided to avoid the inadvertent use of an incorrect breaker in a breaker compartment.
6. Testing and Inspection, reviews items which should be tested or inspected prior to energizing and operating the switchgear.
7. Operating the switchgear, covers how to operate the breakers, and contains information concerning draw-out provisions, doors, and various accessories.
8. Energizing the switchgear, outlines the steps to be taken before and during the electrical energization of the equipment.
9. Maintaining the switchgear, provides instructions for all preventive maintenance, servicing, and lubrication information for the switchgear equipment. Included is service and maintenance data for the circuit breakers, instrument compartments, instruments, bus bar joints, and cable and busway connections. This section also includes paint refinishing requirements.

Appendices A, B, and C, contain information concerning screw and bolt torque values, circuit breaker rejection features, and circuit breaker information.

—
Fig. 1.1
AKD-20 low voltage
switchgear

—
Fig. 1.2
Entellisis low voltage
switchgear

1.3 Related publications

Addenda to this instruction book are the available service and maintenance publications supplied separately for circuit breakers, relays and other devices not described in this instruction book.

In addition to instruction books, the following drawings will be supplied as required for each order of AKD-20 and Entellisis switchgear equipment:

1. General arrangement drawings, including front view and floor plan.
2. Elementary and connection drawings (or wiring routing tables) which indicate and identify test and connection points including terminal blocks, device studs, switch contact developments, and remote connections.
3. Summary of switchgear equipment which is a list of all the components furnished with the switchgear, including the breakers, identified by catalog number.

These are all the documents necessary to install, operate, and maintain the equipment. One complete set of drawings and instruction books is shipped with the equipment.



—
Fig. 1.1

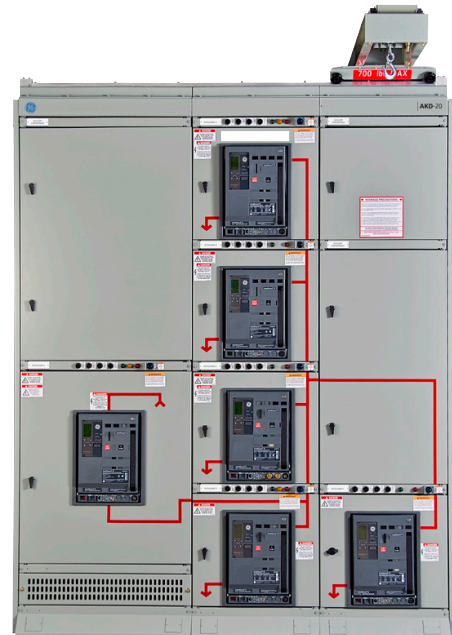

—
Fig. 1.2

2. Receiving, handling and storage

2.1 Receiving

Equipment packages

Every package leaving the factory is plainly marked with the case number, requisition number, and customer's order number. If the equipment has been split for shipment, the section numbers of the equipment enclosed in each shipping package are identified.



Note: To avoid the loss of any parts when unpacking, the contents of each container should be carefully checked against the packing list before discarding the packing material.

Remarque: Pour éviter toute perte de pièces au cours du déballage, vous devez soigneusement comparer le contenu de chaque boîte au bordereau d'expédition avant de jeter le matériel d'emballage.

The contents of each shipping package are listed on the Master Packing List. In addition, this list includes the number of the shipping crate in which miscellaneous parts needed to install and operate the equipment (such as hardware, contact lubricant, touch-up paint, breaker closing devices, etc.) are located. Normally, such devices are packed in a cardboard carton and the carton secured in an empty switchgear compartment. See Fig. 2.1. If such items are packed in a switchgear section instead of a separate crate, the list will indicate the appropriate section number in which they are stored. Large items (such as breaker lifting devices and dollies used with indoor equipment) will always be shipped in separate crates or cartons. See Fig. 2.2.

Inspecting for damage

All equipment leaving the factory is carefully inspected and packed by personnel experienced in the proper handling and packing of electrical equipment. Upon receipt of any equipment, immediately perform a visual inspection to ascertain if any damage has been sustained in shipping or if there are any loose parts. Circuit breakers may be shipped separately in individual containers with the breaker in the open position.

Circuit breakers should be unpacked and visually inspected for damage or loose parts as soon as possible after they have been received.

Be sure to inspect all devices mounted or packed inside compartments of each section to see if any have been dislodged or damaged.

Filing a claim

If any damage is evident, or indication of rough handling is visible, file a claim for damage at once with the transportation company and notify your ABB sales representative immediately. Information on damaged parts, part number, case number, requisition number, etc., should accompany the claim.

—
Fig. 2.1
Packaging of loose
material for shipment

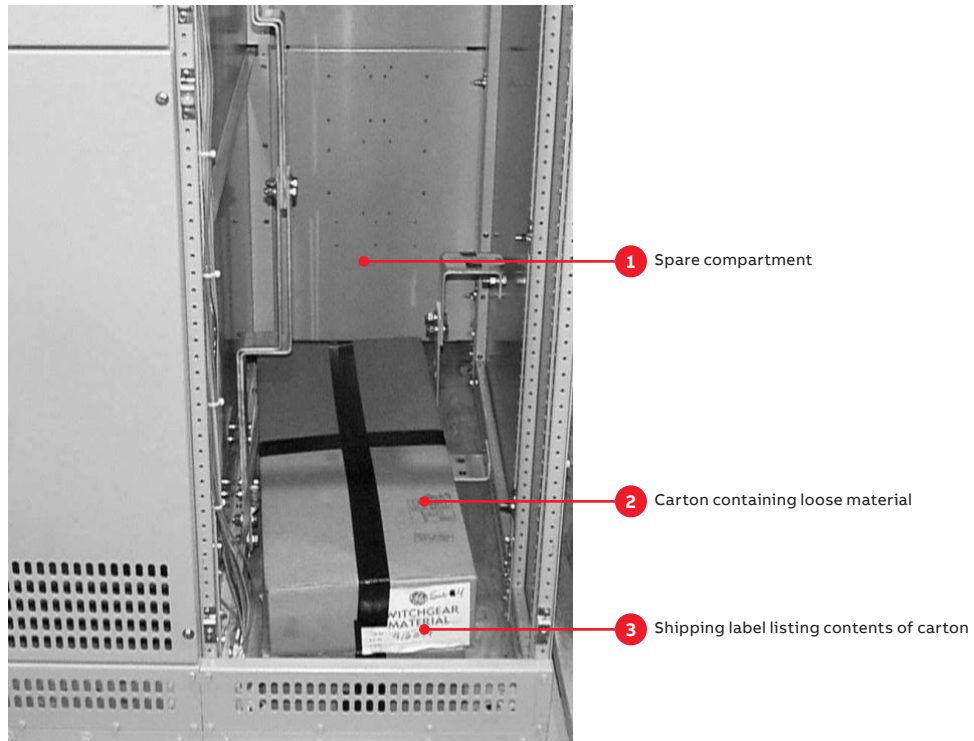

—
Fig. 2.2
Carton containing
breaker lifting device



2.2 Handling



Note: It is preferable to leave the shipping skids in place under the switchgear until it reaches its final location. The equipment should be installed in its final location prior to installing the circuit breakers.

Remarque: Il est préférable de conserver les cales d'expédition à leur place sous l'appareillage électrique jusqu'à ce que celui-ci ait atteint sa destination finale. Installez l'équipement dans son emplacement final avant d'installer les disjoncteurs.

Indoor enclosure lifting

The indoor switchgear sections are best handled by lifting with a crane as shown in Fig. 2.3. Removable lifting plates are provided, as standard equipment, on the top of each switchgear section. To preserve the external appearance of the equipment, it is suggested that the lifting plates be left in place except where adjacent equipment must be bolted together, i.e. shipping splits, etc.

Utilize four equal length cables and an overhead crane, each with a minimum load rating of twice the weight of the switchgear. Estimated weights for shipping splits appear on the Front View drawings.

Example: Switchgear section weight = 5,000 pounds. The crane and the four lift cables must have a minimum load lifting capacity of 10,000 pounds.

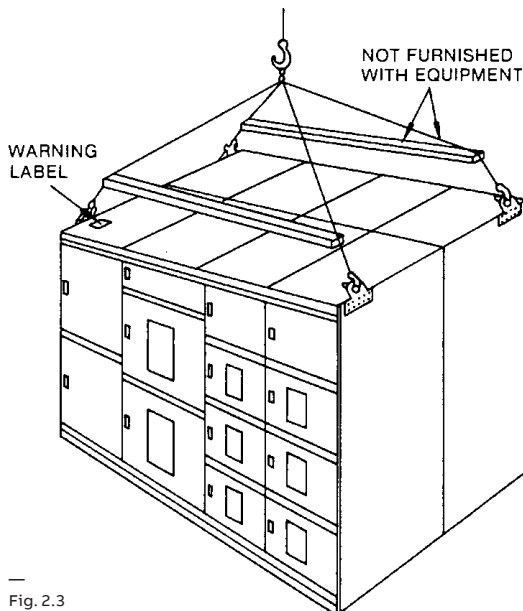

Fig. 2.3
Recommended method of
lifting indoor enclosure



Note: The angle between the cables and the top of the equipment must be at least 45 degrees. If this is not possible because of lack of headspace, spreader bars must be used. Also, lift cables with greater load capability may be necessary, depending upon the angle between the cables and the crane hook.

Remarque: L'angle entre les câbles et le haut de l'équipement doit être d'au moins 45 degrés. Si l'espace est insuffisant pour cela, vous devez utiliser des barres d'écartement. Il est également possible que vous ayez à utiliser des câbles de levage présentant une capacité de charge supérieure, en fonction de l'angle existant entre les câbles et le crochet de la grue.

Connect a cable from the crane to the four lifting plates located on the top-front and rear of the switchgear (Fig. 2.3).

WARNING

When lifting this equipment, use lifting holes provided. Angle of sling must not be less than 45 degrees. If head space is insufficient, use a spreader bar. Refer to Instructions and Operations Manual.

AVERTISSEMENT

Lorsque vous soulevez cet équipement, utilisez les trous de levage fournis. L'angle de l'élingue ne doit pas être inférieur à 45 degrés. Si l'espace de tête est insuffisant, utilisez une barre d'écartement. Reportez-vous au Manuel d'Instructions et Opérations.

ADVERTENCIA

Cuando levante el equipo, utilice los agujeros de transporte proveídos. El ángulo de la eslinga no debe ser inferior a 45 grados. Si el espacio de cabeza es insuficiente, utilice una barra separadora. Consulte el Manual de Instrucciones y Operaciones.

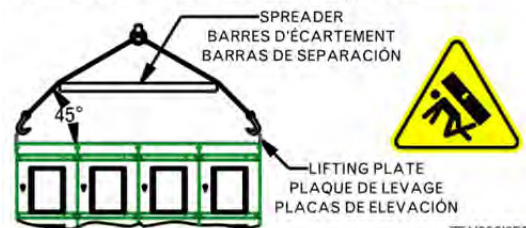

75A106316P201

Warning label is located on each corner by the lifting plate

Fig. 2.4
Location of lifting plates
of outdoor enclosure

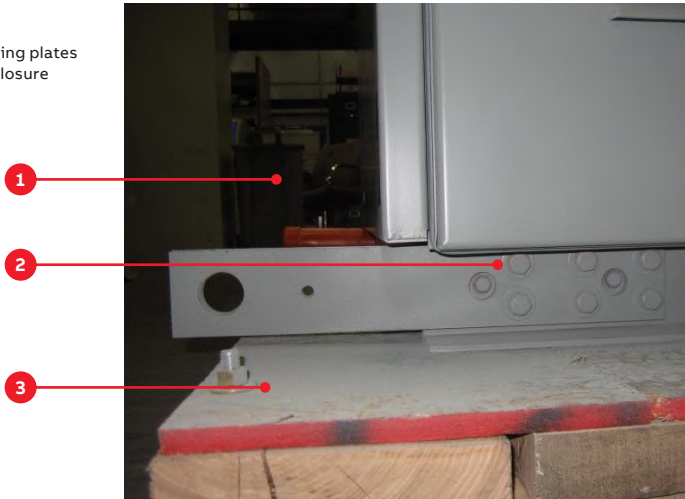

- 1. Lifting plate
- 2. Lifting plate mounting bolts
- 3. Shipping skid

⚠ WARNING

When lifting outdoor equipment, use lifting plates provided along with spreader bars and timber (which are not furnished with switchgear).

Refer to Instructions and Operations Manual.

⚠ AVERTISSEMENT

Lorsque vous soulevez l'équipement extérieur, utilisez les plaques de levage fournies avec les barres d'écartement et le bois (qui ne sont pas fournis avec l'appareillage de commutation.)

Reportez-vous au Manuel d'Instructions et Opérations.

⚠ ADVERTENCIA

Cuando levante el equipo al aire libre utilice placas de elevación junto con barras de separación y madera (que no están equipadas con aparatura).

Consulte el Manual de Instrucciones y Operaciones.

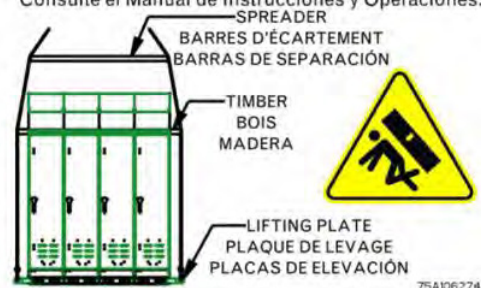

Warning label is located on each side by the lifting plate

Fig. 2.5
Recommended method
of lifting outdoor
enclosure (using
cable spreaders)

Spreaders and timber not furnished with equipment

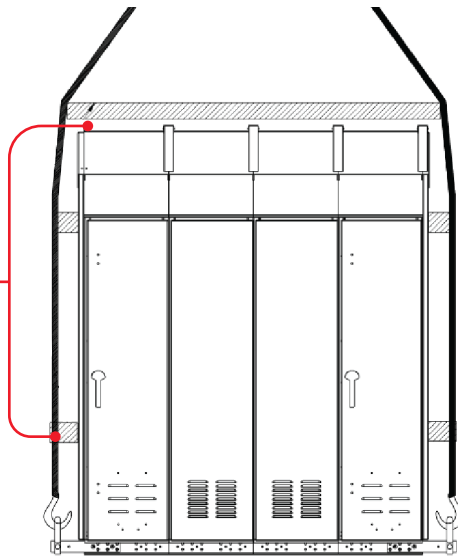

Front view

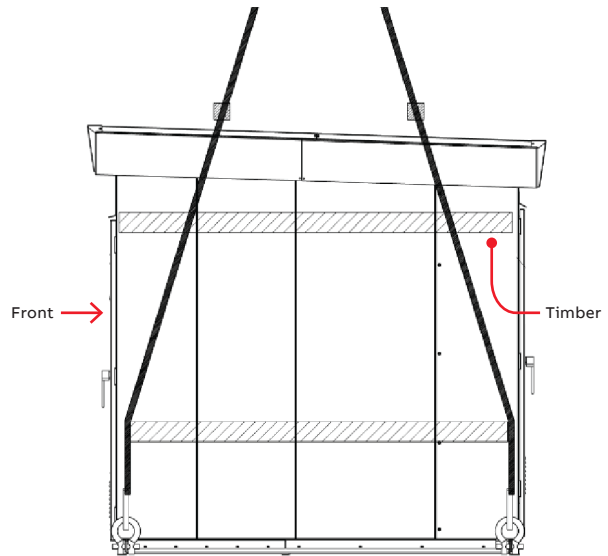

Side view

Take up the slack in the lifting device very carefully and manually stabilize the switchgear to prevent it from rotating.



Warning: Do not stand under switchgear while it is being moved. Serious injury may occur if the cables or lifting device fail.

Avertissement: Ne restez pas sous l'appareillage électrique tant que celui-ci est en mouvement. Des blessures graves sont possibles en cas de chute des câbles ou du dispositif de levage.



Caution: Gently lower the switchgear section onto the level site location. If the switchgear is roughly handled or jarred, it is possible to damage or misalign internal components.

Prudence: Abaissez doucement l'appareillage électrique sur un emplacement plat. Si vous manipulez cet appareillage brutalement ou s'il subit des secousses, vous risquez d'endommager ou de désaligner ses composants internes.

Outdoor enclosure lifting

Methods of lifting outdoor switchgear sections are much the same as for indoor equipment except the lifting plates are provided at the base of the structure. See Fig. 2.4.

If lifting outdoor switchgear sections, side support timbers must be placed along the sides to prevent any damage that could be caused by the lifting cables. In addition, spreader bars must be inserted between each lift cable, both front and rear. Spreader bar locations must be on the sides and above the switchgear equipment as shown in Fig. 2.5. Proceed to lift and place the outdoor switchgear utilizing all the precautions and requirements that apply to lifting the indoor switchgear. The lifting plates, Fig. 2.4, should be removed after the equipment is permanently anchored so passageways at the ends of the equipment will not be obstructed.

Rollers

If crane facilities are not available, the equipment may be moved into position by means of construction rollers placed under the shipping skids. The switchgear may be raised enough for the placement of rollers by means of a fork lift or jack.

There should never be less than four rollers under the equipment unless the line-up is less than five feet long. Use one roller for each 18 inches of equipment length.

Forklifts

When using a forklift to raise the line-up to position rollers underneath, proceed as follows:

1. Expand forklift tines to their maximum (widest) extension.
2. Carefully insert tines of forklift below one side of the switchgear line-up at the approximate center of the panel as shown in Fig. 2.6.



Note: Do not attempt to lift or move the equipment with a forklift positioned in the front or rear of the equipment.

Remarque: Ne tentez pas de soulever ou déplacer l'appareil avec un chariot élévateur positionné à l'avant ou à l'arrière de l'équipement.

3. Raise equipment and position one roller under the skids close to the raised end of the line-up.
4. Carefully lower the gear until it rests on the roller as shown in Fig. 2.7.
5. Repeat the lifting process at the other end and place the appropriate number of rollers under the skids spacing them evenly across the width of the line-up.

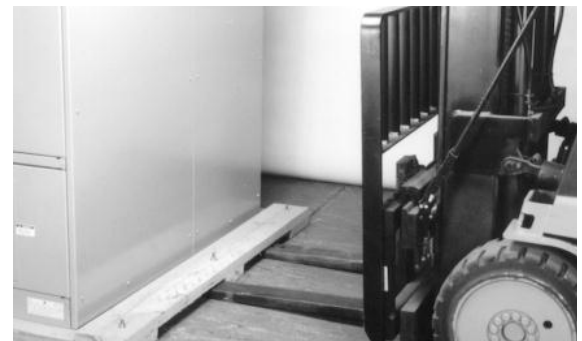

—
Fig. 2.6
Placing forklift tines
under equipment
shipping skid



—
Fig. 2.7
Placement of rollers
under shipping skid

Fig. 2.8
Method of rolling
equipment into place

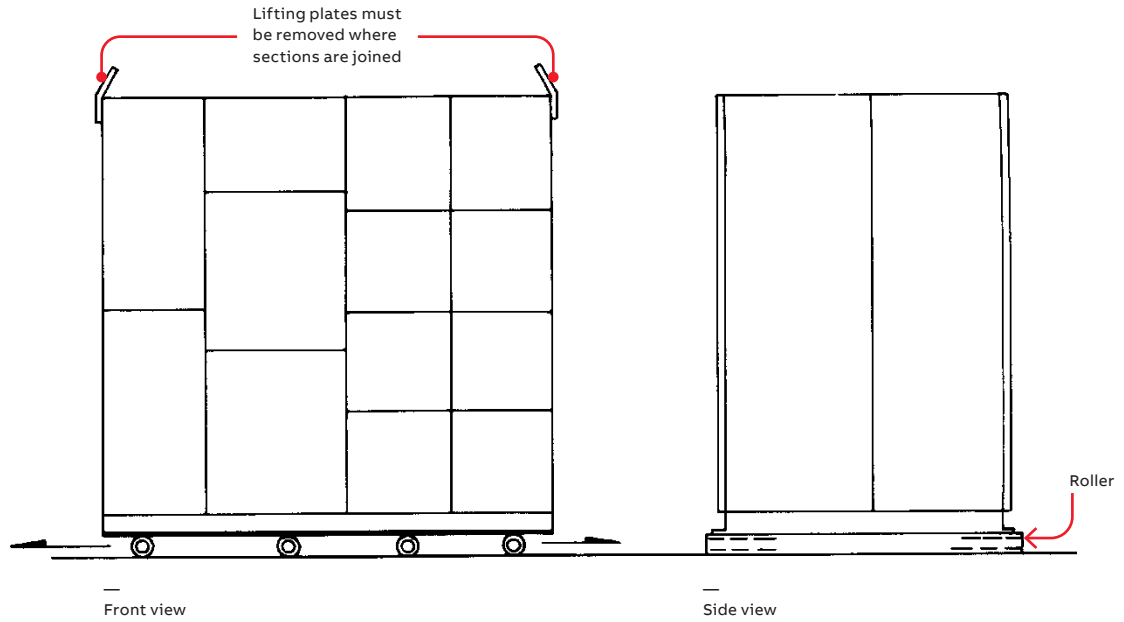
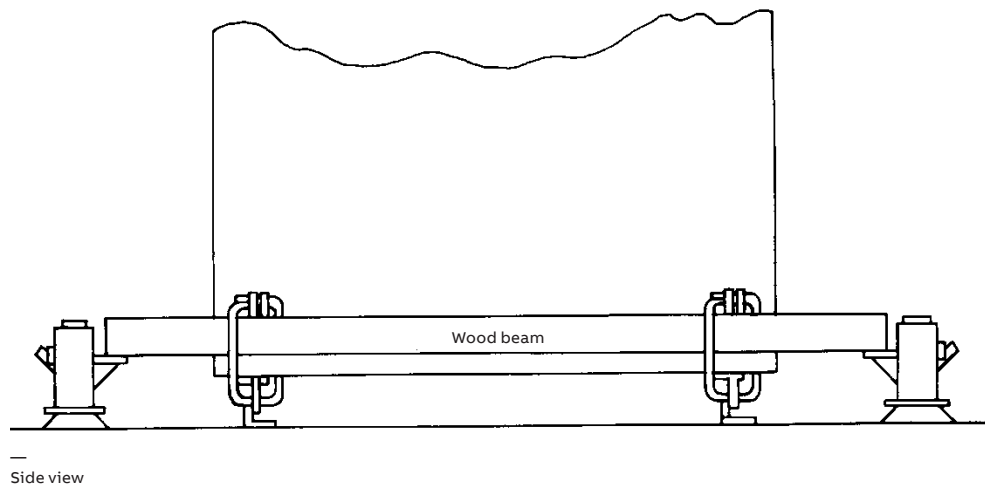

Fig. 2.9
Recommended
method of jacking
outdoor equipment



Note: If shipping skids are removed prior to final placement of equipment, rollers may only be used to move the equipment in a direction parallel to the front.

Remarque: Si vous retirez les cales d'expédition avant le placement final de l'équipement, vous pouvez utiliser des rouleaux pour le déplacer, uniquement dans le sens parallèle à l'avant.

6. Carefully lower the gear until it rests on the rollers (Fig. 2.7).
7. While carefully pushing the switchgear to its final site position, the rollers that are freed from the rear of the switchgear are then repositioned at the forward end. This procedure should be continued until the switchgear is in its final location (Fig. 2.8).
8. When the switchgear is in its final position, remove all lug bolts holding the shipping skids to the switchgear line-up.
9. Insert the tines of the forklift at one end of the line-up, raise slightly, and remove the loose rollers.
10. Lower the end of the gear carefully to the floor.
11. Raise the other end of the line-up slightly and remove the remaining roller at that end.

Fig. 2.10
Recommended
method of jacking
outdoor enclosure

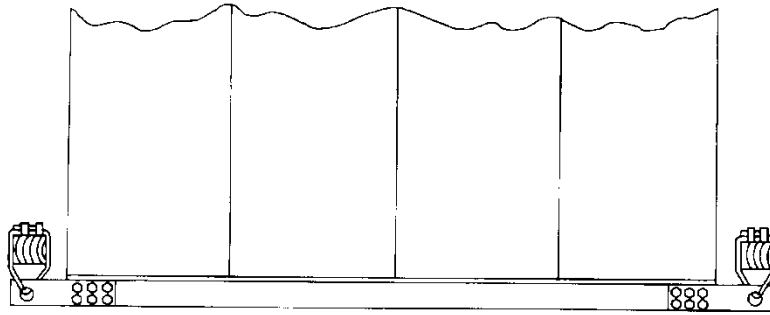

Front view

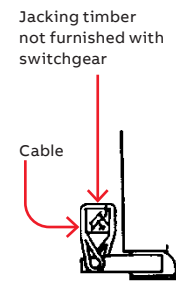

Partial front or rear
view of jacking

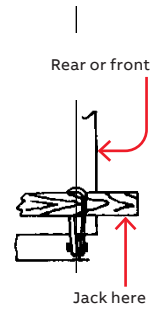

Partial side view
of jacking

Jacks

Jacks may be used in place of forklifts to raise and lower switchgear.

1. Place a jack under the front and rear corners of one end of the line-up. Fig. 2.9 and 2.10 illustrate the use of jacks with outdoor equipment.



Caution: Do not place jacks in any other location other than the front and rear corners of the switchgear. Doing so may result in serious damage to the switchgear equipment.

Prudence: Ne placez pas de vérins ailleurs que dans les coins avant et arrière de l'appareillage électrique. Vous risqueriez d'endommager gravement l'appareillage.

2. Raise the switchgear evenly and just enough to position a roller beneath the equipment. Gently lower the switchgear onto the rollers. Repeat the procedure at the opposite end of the switchgear, raising the gear far enough to place the appropriate number of rollers under the skids, spacing them evenly across the width of the line-up. Gently lower the gear onto the rollers.
3. While carefully pushing the switchgear to its final site position, the rollers that are freed from the rear of the switchgear are then repositioned at the forward end. This procedure should be continued until the switchgear is in its final location.
4. When the switchgear is in its final position, remove all lag bolts holding the shipping skids to the switchgear line-up.
5. Place one jack at each corner, front and rear, of the switchgear. Carefully raise the line-up evenly and remove the rollers and the shipping skids. Evenly lower the line-up to the floor and remove the jacks.

2.3 Storage

Switchgear

If it is necessary to store the switchgear equipment for any length of time, the following precautions should be taken to prevent corrosion or deterioration.

1. Remove protective covering. Check thoroughly for damage.
2. Store in a clean, dry, rodent-free location with moderate temperature and provide protective coverings to prevent dirt, water, or other foreign substances from entering the switchgear.



Caution: Remove all cartons, containers and any other miscellaneous packaging and packing material from inside the switchgear sections before energizing any internal heaters. To prevent fire, remove any plastic or polyethylene shrouding from the switchgear sections before energizing any internal heaters.

Prudence: Retirez tous les cartons, boîtes et autres matériaux d'emballage de l'intérieur de l'appareillage électrique avant d'allumer les éléments thermiques internes. Pour éviter tout risque d'incendie, retirez tout bâchage en plastique ou polyéthylène de l'appareillage avant d'allumer les éléments thermiques internes.

3. If dampness or condensation may be encountered in the storage location, heaters must be placed inside the switchgear sections to prevent moisture damage. Approximately 250 watts of heat in each section is required. On outdoor switchgear equipment, this may be accomplished by making a temporary power supply connection to the heaters already installed in the equipment.



Caution: If the space heaters are to be temporarily energized from external source, it is important to remove the fuses on the secondary side of the control power transformer. This precaution is to prevent a feedback of higher voltage to other portions of the equipment through the CPT primary.

Prudence: Si les générateurs doivent être temporairement allumés à partir d'une source externe, il est important de retirer les fusibles du côté secondaire du transformateur d'alimentation. Ceci permet d'éviter tout retour de tension plus élevée vers d'autres parties de l'équipement via le primaire du transformateur.

Circuit breakers

If circuit breakers are not to be placed into service at once, remove them from their shipping cartons and thoroughly inspect them for damage. If the breakers are in satisfactory condition, replace the breakers in their shipping cartons for storage. Do not remove the circuit breaker shipping members at this time.

Store the circuit breakers in a clean, dry location in an upright position. They must be properly supported to prevent bending of the studs or damage to any of the breaker parts. Do not remove any protective grease until the circuit breakers are ready to be installed. A plastic or canvas-type cover should be provided to reduce the possibility of damage to the breakers due to dust and water.

3. Switchgear description

3.1 Receiving

This section contains a description of the ABB low voltage switchgear. It also describes the functions of the electrical and mechanical systems.

Figure 3.1 is a side view of a typical section showing compartmentation.

3.2 Summary description

ABB low voltage switchgear is a freestanding assembly of metal-enclosed sections containing low voltage power circuit breakers, bus bars, cable termination provisions, auxiliary power circuit protective devices, controls, and instrumentation. It may also be an integral part of a load center unit substation, either single-ended or double-ended.

Fig. 3.1
Side-view section of
low voltage switchgear

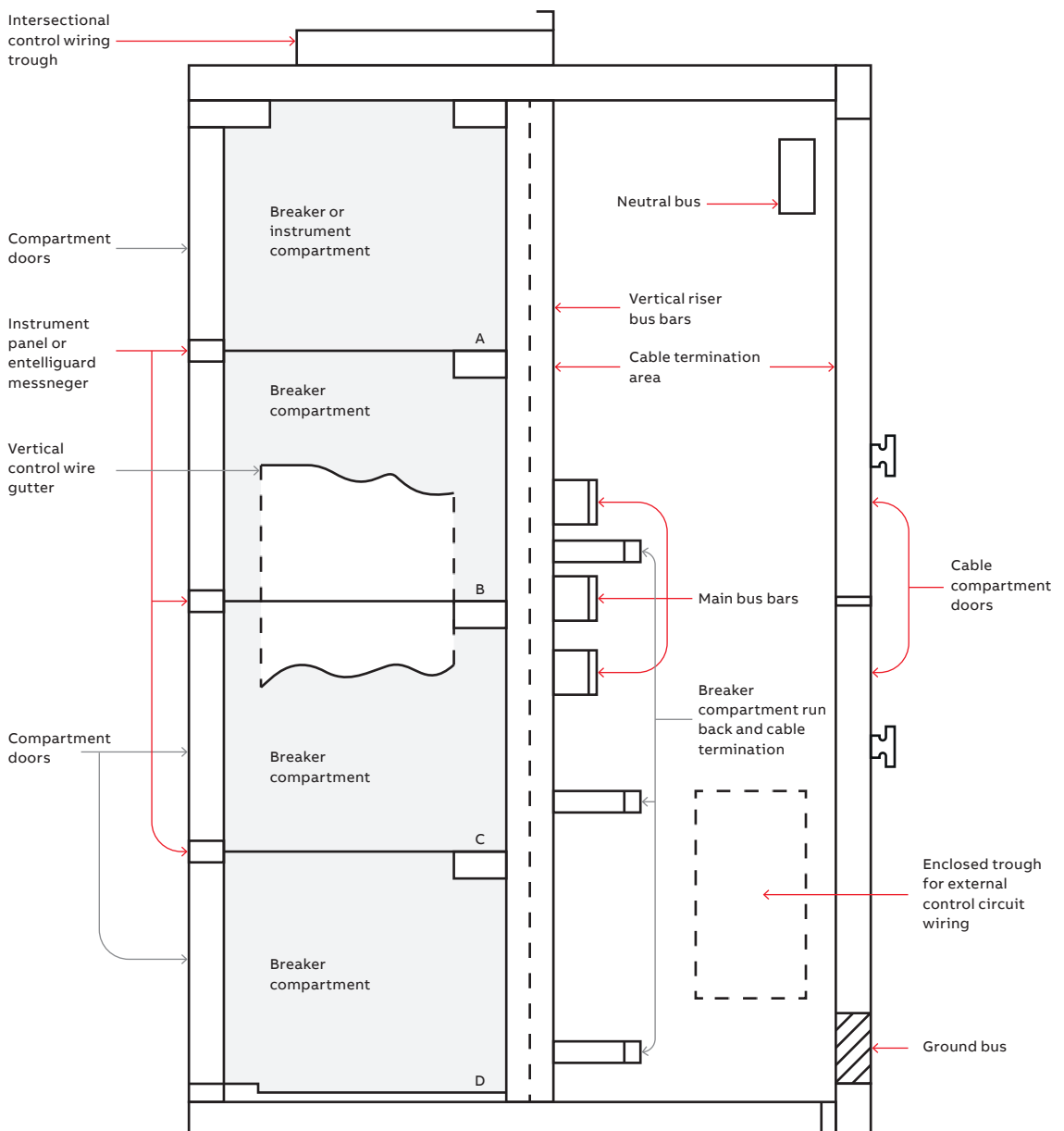

All of the primary circuit switching and protective devices, secondary control and metering devices, control fuses, instrument transformers, and Entellisys instrumentation are mounted in the enclosure. The breaker compartments include draw-out rails, stationary breaker contacts, interlocks, Entellisys Messenger, and necessary control and indicating devices.

The breakers are provided with self-aligning primary and secondary disconnecting contacts, breaker locking mechanism, and integral trip unit. The individual sections, compartments, and devices are described in the following paragraphs. Figure 3.2 is an outline of a typical single-ended load center unit substation illustrating the nomenclature used for all equipment.

Fig. 3.2
Outline of a typical load center unit substation

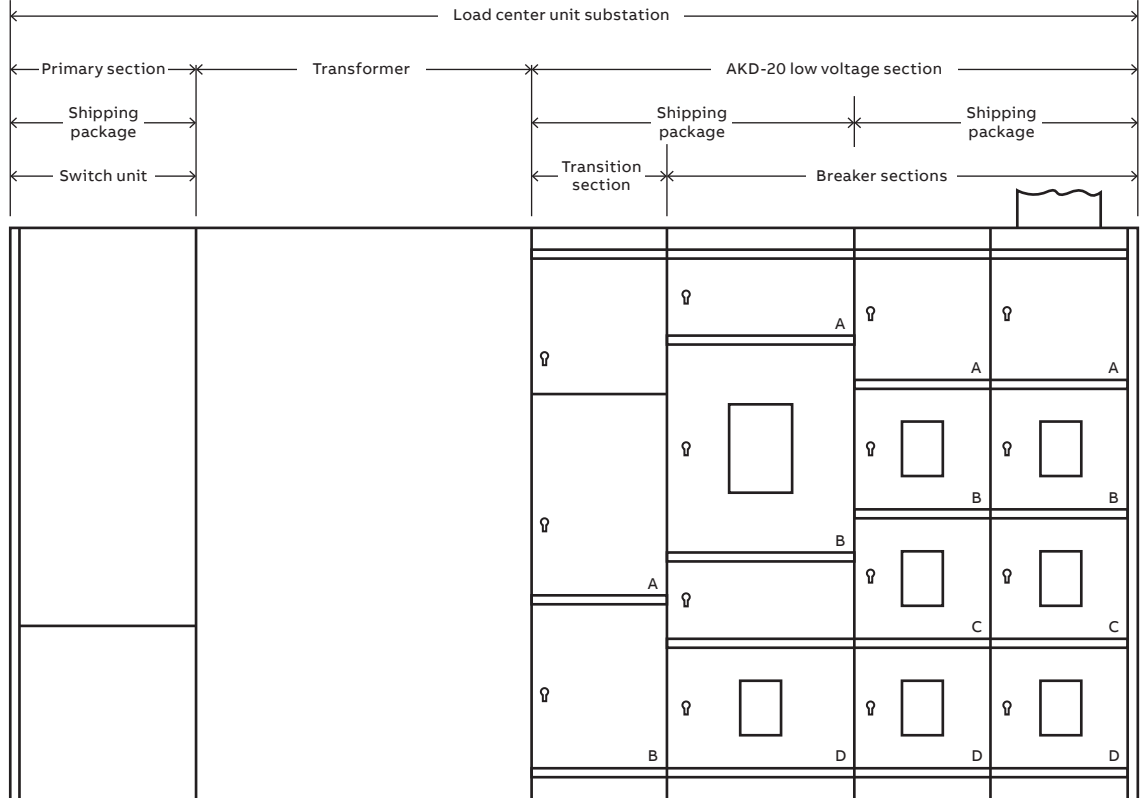

—
Fig. 3.3
AKD-20 instrument panel

3.3 Compartment area

The front enclosure of each section is divided into individual compartments. These compartments house either a low voltage power circuit breaker or are used to mount instruments, control components and other ancillary devices.

3.4 Instrument panel (AKD-20 only)

A standard instrument panel, Fig. 3.3, is located above each breaker compartment eliminating cross-hinge wiring. When required, optional devices may be included and mounted on the front face of the panel such as breaker control circuit fuses, pilot lights, and a RELT switch.

Fuses for the charge, close, and trip circuits of the electrically operated EntelliGuard G breakers are mounted on the panel. Routine wiring inspections and fuse checks or fuse replacements can be performed with the breaker compartment door in the closed position so that operators are protected from the energized primary circuits.



—
Fig. 3.3

- 1. Control circuit fuses
- 2. Pilot lights
- 3. RELT switch and indication

Circuit breaker control fuse panel (Entellisys only)

Control fuses for the charge, close and trip circuits of electrically operated EntelliGuard E circuit breakers are mounted in the middle right side of the cassette, behind the compartment door. Control fuses for the SET and RESET coils of the optional Network Interlock breaker accessory are also mounted on the same panel. See Fig. 3.4.

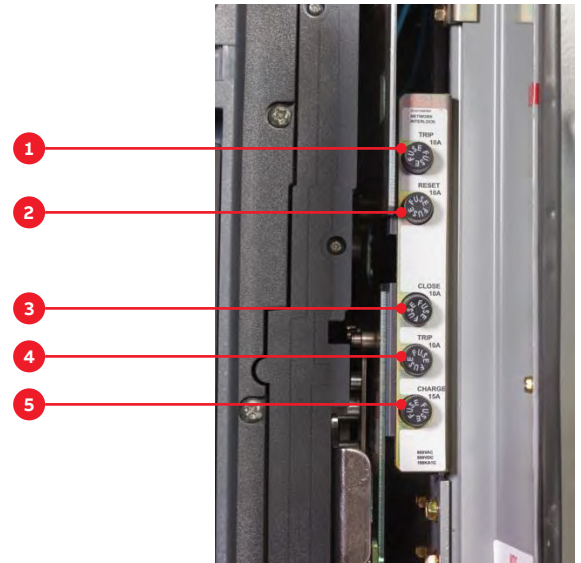

—
Fig. 3.4

- 1. Network interlock trip (set) fuse (optional)
- 2. Network interlock reset fuse (optional)
- 3. Circuit breaker close fuse
- 4. Circuit breaker trip fuse
- 5. Circuit breaker charge fuse

3.5 EntelliGuard messenger (Entellisys only)

An EntelliGuard messenger, Fig. 3.5, is located above each breaker compartment. The messenger provides an interface between the circuit breaker, the breaker compartment, and the Entellisys system. For additional information and instructions, reference DEH-501.



—
Fig. 3.5
Entellisys EntelliGuard messenger

—
Fig. 3.6
Instrument/auxiliary
compartment

—
Fig. 3.7
Entellisis instrument/
auxiliary compartment

3.6 Instrument/auxiliary compartment

An instrument/auxiliary compartment, Fig. 3.6, is available as a standard feature. Relays, fuse cutouts, and similar devices may be installed in the instrument compartment or in adjacent compartments.

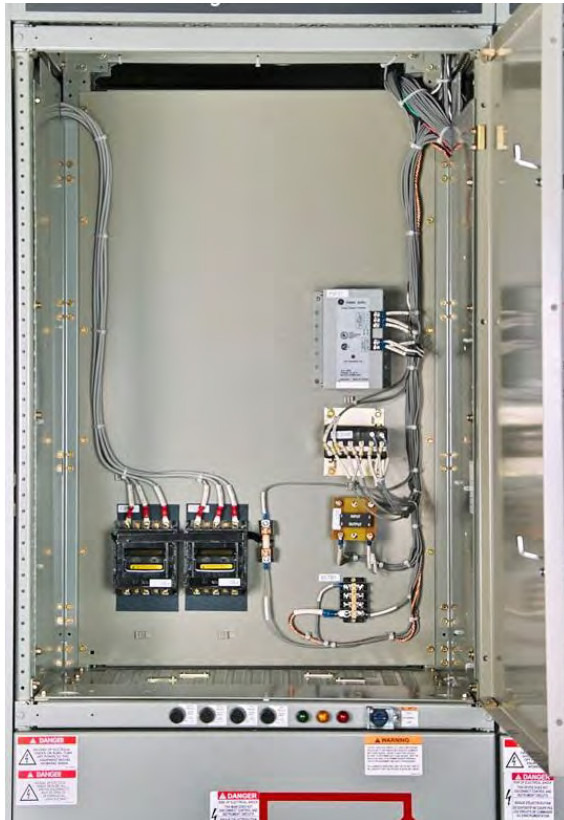

—
Fig. 3.6

Entellisis instrument/auxiliary compartment (Entellisis only)

Each Entellisis low voltage switchgear lineup contains standard devices housed within the instrument compartments, Fig. 3.7. Two CPUs (Central Processing Units) provide the processing capability to support all switchgear functions. At least one HMI (Human-Machine Interface) provides user access to the Entellisis system. Network switches provide communication links between the CPU, the HMI, the EntelliGuard Messengers, and the external world. A pair of uninterruptible power supplies (UPS's) and control power throw-over relays supply highly reliable control power to these system devices. For additional information and instructions, reference DEH-501.



—
Fig. 3.7

1. HMI (Human Machine Interface)
2. Network switches
3. Firewall security device
4. Cpu's (Central processing units)

—
Fig. 3.8
EntelliGuard circuit
breaker compartment

—
Fig. 3.9A
Circuit breaker
compartment
for EntelliGuard
circuit breakers

—
Fig. 3.9B
Circuit breaker
compartment
for EntelliGuard
circuit breakers

3.7 Breaker compartment

Closed-door draw-out circuit breaker compartments, Fig. 3.8, are standard construction with all switchgear equipment. The circuit breaker compartment doors remain closed and latched while the breaker is racked out from the CONNECTED position, through TEST, to the DISCONNECTED position.

Breaker compartment doors do not have any ventilation slots, thus protecting operators from hot ionized gases which may be vented by the breaker during circuit interruption. Additionally, the breaker compartment, Fig. 3.9, is enclosed by grounded steel barriers on the top, sides, bottom, and front. In the back, a flame-retardant, track resistant, glass-filled polyester base minimizes the possibility of fault communication between compartments or to the bus.

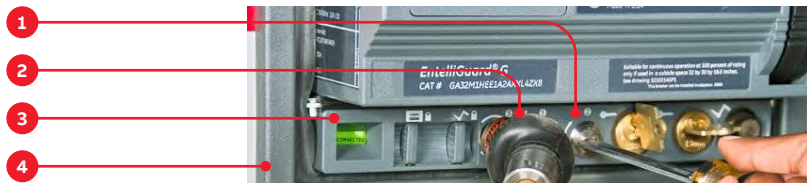

—
Fig. 3.8

- 1. Access port to racking mechanism
- 2. Racking handle
- 3. Breaker position indicator
- 4. Circuit breaker door frame and gasket

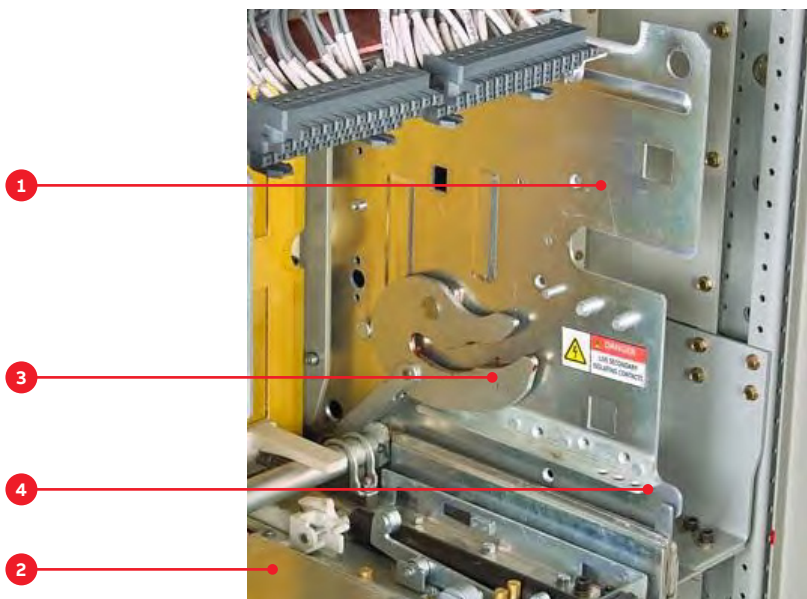

—
Fig. 3.9A

- 1. Cassette side barrier
- 2. Cassette bottom and racking box
- 3. Racking arm
- 4. Draw-out rails

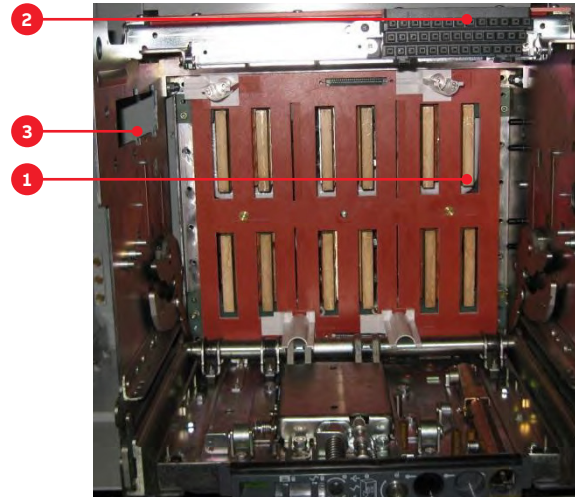

—
Fig. 3.9B

- 1. Primary disconnect stab tip (typical)
- 2. Secondary disconnects
- 3. Position switch location (not shown)

—
Fig. 3.10
EntelliGuard circuit
breaker (rear view)

—
Fig. 3.11
Racking handle
for movement
of EntelliGuard
circuit breakers

The cassette racking arm slots engage fixed racking anchor pins on the sides of the breaker. As the racking arms are rotated by operation of the racking handle, the breaker is pulled into the compartment, and locked in its final connected position.

The breaker should always be OPEN when it is moved into or out of the CONNECTED position. As a safeguard, a draw-out interlock will prevent access to the racking mechanism unless the breaker is OPEN.

All EntelliGuard circuit breakers are provided with a mechanical rejection feature. See section 5 of this instruction book for additional details.

Each circuit breaker compartment has four positions as described in the Table 3.1.



Note: Items shown in Figs. 3.9, 3.12, and 3.13 (such as secondary disconnects and shutters) are optional and may appear in any compartment or not be included at all, depending on the equipment specified.

Movement of the breaker between the CONNECTED, TEST, and DISCONNECTED positions is performed by the use of a racking handle, see Fig 3.11, which engages the racking mechanism mounted on the cassette. An optional remote racking device is also available. Movement to the WITHDRAWN position is manually performed after opening the compartment door. These positions are illustrated and described more fully in Section 5 of this instruction book.



Caution: The door should NOT be opened when the circuit breaker is closed and in the CONNECTED position. Although the breaker compartment door may be opened in any position, it is recommended that the door only be opened when the breaker is in the DISCONNECTED or WITHDRAWN position.

Prudence: Vous ne devez PAS ouvrir la porte lorsque le disjoncteur est fermé et en position CONNECTED (connectée). Bien que vous puissiez ouvrir la porte du compartiment d'un disjoncteur dans n'importe quelle position, nous vous recommandons de l'ouvrir uniquement lorsque le disjoncteur est en position DISCONNECTED (déconnectée) ou WITHDRAWN (retirée).

Table 3.1 - Description of the circuit breaker positions

Circuit breaker position in the cassette	Primary disconnects	Secondary disconnects	Shutter assembly	Circuit breaker functionality	Circuit breaker door position
Connected	Engaged	Engaged	Opened	<ul style="list-style-type: none"> • Breaker can be operated mechanically or electrically. • Breaker ready for service. 	Closed
Test	Disengaged	Engaged	Closed	<ul style="list-style-type: none"> • Breaker can be operated mechanically or electrically. • Breaker and control circuits operations can be tested and verified. 	Closed
Disconnected	Disengaged	Disengaged	Closed	<ul style="list-style-type: none"> • Breaker can be operated only mechanically. • Breaker cannot be removed from the circuit breaker compartment. 	Closed
Withdrawn	Disengaged	Disengaged	Closed	<ul style="list-style-type: none"> • Breaker can be operated only mechanically. • Breaker can be removed from the compartment. 	Open

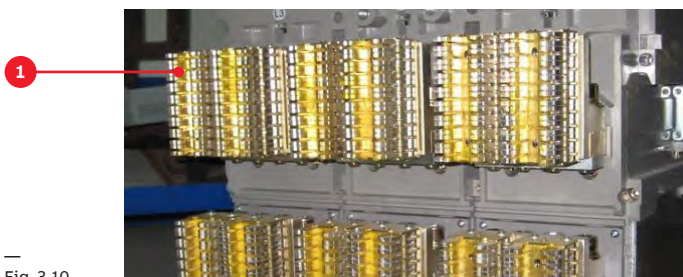

—
Fig. 3.10

1. Primary disconnect



—
Fig. 3.11

1. Racking handle
2. Breaker position indicator

—
Fig. 3.12
Primary disconnect
shutter assembly (shown
in closed position)

—
Fig. 3.13
Primary disconnect
shutter assembly (shown
in open position)

Primary disconnect shutters

Primary disconnect shutters, Fig. 3.12, are available as options to provide protection against contact with the energized stationary primary disconnects when the breaker is removed from its compartment. Shutters are supplied as standard components in the main and tie breaker compartments of double-ended substations.

The shutters are constructed from glass-reinforced polyester insulating material. The shutters (movable barriers) prevent frontal access to the primary disconnect line and load stationary disconnects.

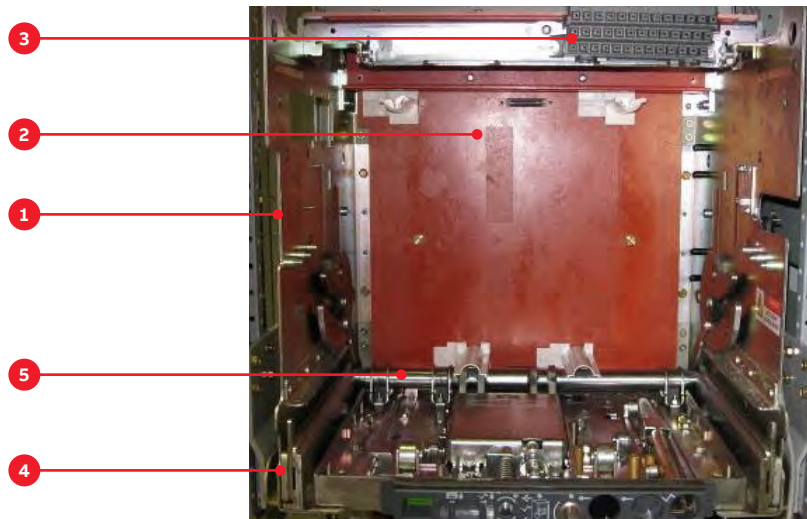

—
Fig. 3.12

1. Cassette side barrier
2. Shutter assembly (closed)
3. Secondary disconnects
4. Draw-out rails
5. Racking shaft

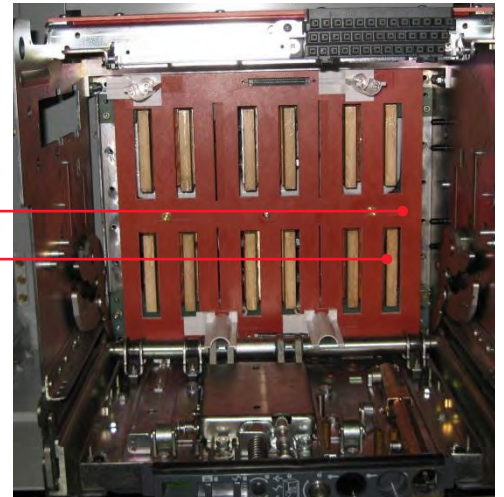

—
Fig. 3.13

The shutters are closed when the breaker is in the DISCONNECT Position. As the circuit breaker is racked from the DISCONNECT Position to the TEST Position the shutters remain fully closed. As the breaker is racked from the TEST Position to the CONNECTED Position, the shutters open allowing the breaker to connect to the primary disconnects.

Figure 3.13 shows the shutter assembly with the shutter in the open position.



Danger: Hazard of electrical shock or burn.
Turn off power to this equipment before working inside.

—
Fig. 3.14
EntelliGuard E
circuit breaker

—
Fig. 3.15
EntelliGuard G circuit
breaker (shown with
draw-out rails extended)

3.8 Circuit breakers

The EntelliGuard low voltage power circuit breaker includes spring-operated, stored energy, close and trip mechanisms for either manual or electrical operation.

EntelliGuard circuit breakers form the complete family of breakers used in the AKD-20 and Entellisys switchgear. Each type of breaker listed in Table 3.2 describes the breaker interrupting rating which corresponds to the 5th digit of the breaker catalog number. These circuit breakers range from 400 to 5,000 ampere frame size.



—
Fig. 3.14

EntelliGuard circuit breakers

Envelope 1 EntelliGuard circuit breaker

- 2,000 ampere frame size;
- Up to 100kAIC interrupting rating;
- Four high stacking; 22 inch wide sections.

Envelope 2 EntelliGuard circuit breaker

- 2,000 ampere frame size;
- Up to 100kAIC interrupting rating;
- Four high stacking; 22 inch wide sections.

Envelope 2 EntelliGuard circuit breaker

- 3,200 ampere frame size;
- Up to 100kAIC interrupting rating;
- Available in 22 inch wide sections.

Envelope 3 EntelliGuard circuit breaker

- 5,000 ampere frame size;
- Up to 150kAIC interrupting rating;
- Available in 38 inch wide sections.



—
Fig. 3.15

Table 3.2 - EntelliGuard short time and short circuit interruption ratings

Interrupting Rating Tiers ANSI/ UL1066 Devices, LVPCB					Envelope 1 ²		Envelope 2 ²		Envelope 3	
Type	254 Vac	508 Vac	635 Vac	1/2S Withstand	400, 800, 1200	400,800, 1600, 2000	3200	400-3200	3200	4000- 5000
S	65,000	65,000	50,000	50,000	x					
N	65,000	65,000	65,000	65,000		x	x			
H	85,000	85,000	65,000	65,000		x				
P	100,000	100,000	65,000	65,000		x				
M	100,000	100,000	100,000	85,000				x		x
E	85,000	85,000	85,000	85,000				x	x	x
B	100,000	100,000	100,000	100,000					x	x
L	150,000	150,000	100,000	100,000					x	x
W ¹	200,000	200,000	100,000	100,000					x	x

1. Contact factory
2. EntelliGuard E Circuit Breakers exclude 400A and 1,200A ratings

—
Fig. 3.16
Future breaker
compartment

—
Fig. 3.17
Future breaker door cover
(pad-lockable ¼-turn
latch may be provided on
future breaker cubicles)

—
Fig. 3.18
Auxiliary/transition
section (partial
front view)

3.9 Compartments for future breakers

When specified, compartments may be supplied for future addition of circuit breaker elements. These compartments are fully equipped with draw-out rails, primary disconnects, and ancillary devices as required (i.e. secondary disconnects, accessory devices, etc.). The opening in the breaker compartment door is closed with a bolted-on steel plate to deter accidental contact with energized electrical circuits (i.e. primary disconnect stab tips). See Fig. 3.16 and 3.17.

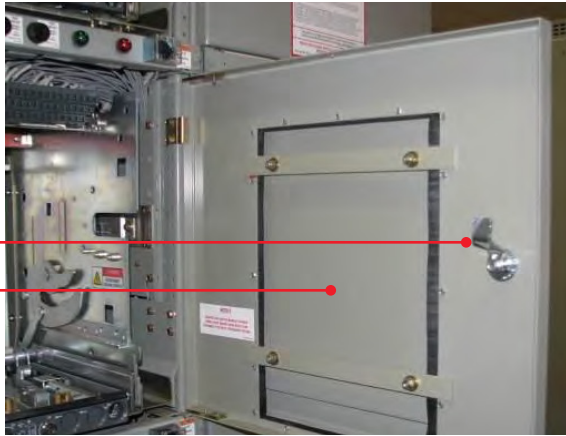

—
Fig. 3.16

1. Quarter-turn latch
2. Steel plate (future cubicle door cover)

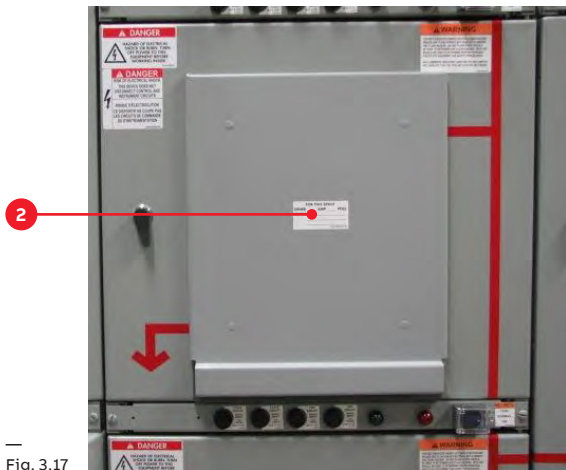

—
Fig. 3.17

1. Future cubicle door cover

3.10 Auxiliary/transition sections

Sections may be provided for any one or more of several reasons including:

- Transition to a close-coupled transformer;
- Transition to "match and line-up" with existing AKD-8/AKD-10/AKD-20 and Entellisys switchgear;
- Incoming cable or busway when a main breaker section is not provided;

- Mounting and wiring of additional metering, relaying, and control devices requiring more space than available in a standard instrument panel or instrumentation compartment (transition or auxiliary);
- Mounting and wiring of purchaser specified and/or furnished devices (i.e. utility revenue metering equipment, etc.).

Auxiliary sections may be 22-inch, 30-inch, or 38-inch wide as required to accommodate the space requirements. The compartment doors on the front of the sections are hinged and latched in the same manner as breaker compartment doors.

Generally, transition sections will be 22-inches wide for close-coupling to transformers and "match and line-up" to non-ABB equipment.

Power company metering requirements generally require either a 38-inch or 49-inch wide auxiliary section to accommodate the current transformers, kilowatt-hour meters, demand meters, etc. as required by their individual practices, tariff schedules, and/or regulatory commissions.

Figure 3.18 is a front view of a typical instrumentation compartment.

Examples of primary and secondary control protection in the instrument compartment are shown in Fig. 3.19.

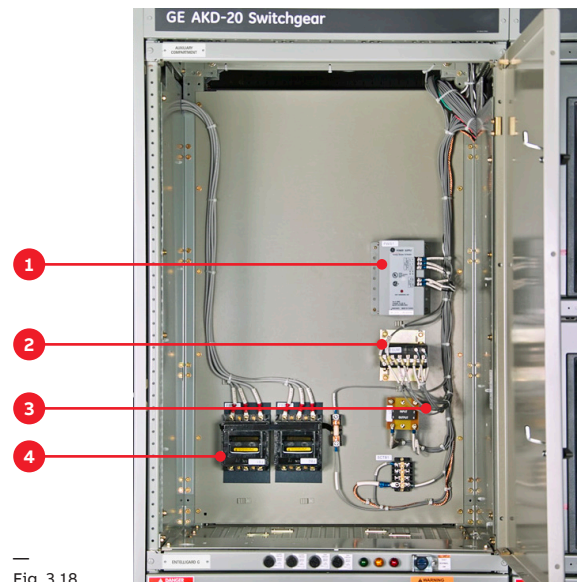

—
Fig. 3.18

1. 24V power supply
2. Auxiliary summing ct
3. Voltage conditioners
4. Enclosed fuse block

—
Fig. 3.19
Auxiliary/transition
compartment
(primary and secondary
circuit fusing)



—
Fig. 3.20
Auxiliary/transition
compartment

—
Fig. 3.21
Bus construction

Fig. 3.19

1. Enclosed fuse block
2. Open fuse block

Figure 3.20 illustrates an auxiliary/transition compartment with switchgear-type relays mounted in semi-flush draw-out cases installed on the compartment door. Space in the compartment has been used for power management components and other control devices.

3.11 Bus area

The bus area, Fig. 3.21, contains the main horizontal bus and vertical riser bus bars for the particular section. The vertical bus bars are supported at the breaker run-ins which are bolted to the molded bases that form the rear wall of the breaker compartment. The horizontal bus bars are supported by the power connectors which are bolted to the vertical bus bars. All bolted supports and connections are accessible from the rear for maintenance. The bus area is fully isolated from the breaker, instrument and auxiliary compartments by the molded bases or glass polyester sheet.

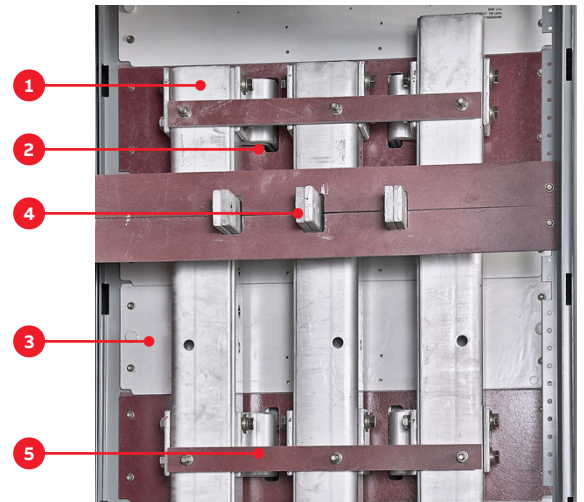

Fig. 3.21

1. Vertical riser bus
2. Run-ins to breaker compartment
3. Molded base
4. Run-backs from breaker compartment
5. Short-circuit brace

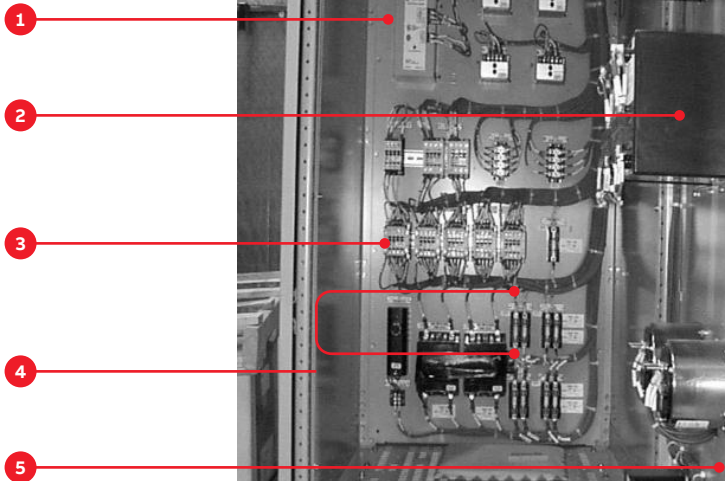

Fig. 3.20

1. Power supply
2. Relays in draw-out cases
3. Auxiliary relays
4. Fuse blocks
5. Compartment door

—
Fig. 3.22
Main breaker
arrangement

Busing system

Bus bars are fully tin-plated copper with bolted joints and silver plating is optional. The standard construction is open bus. A barrier system (Bus Compartmentation) that isolates the main and vertical bus bars from the cable area is available as an option. All run-backs (load-side power conductors) from the breaker compartment to the cable termination area are covered with non-PVC insulated tubing.

The typical arrangement is shown in Fig. 3.22 on the next page.

The standard bracing is 65,000 amperes, RMS symmetrical. Bracing for 100,000, 150,000 and 200,000 amperes, RMS symmetrical is available as an option.

In general, when the switchgear equipment has no more than four sections or does not exceed 10 feet in length, it will be shipped as one complete lineup. In such cases, the only field assembly would be to a close-coupled transformer if, the switchgear were part of a Load Center Unit Substation. If, because of shipping and/or handling considerations, the equipment cannot be handled in one piece, it can be split into two or more shipping sections at the factory. The individual shipping splits require both mechanical and electrical connections between sections to be made in the field.

At these shipping splits, provisions are made for bolting all buses and making the necessary electrical and mechanical connections. These are described in Section 4 of this publication.

On main and tie breakers, the bus area is divided into an upper and lower section by a glass reinforced polyester isolation barrier. For typical unit substation main circuit breakers, the upper section contains the incoming line bus. The lower section of the bus area contains the load side main bus (protected by the main breaker) which feeds all sections of the switchgear equipment. Similarly, barriers at tie breakers isolate the two main bus sections from each other.

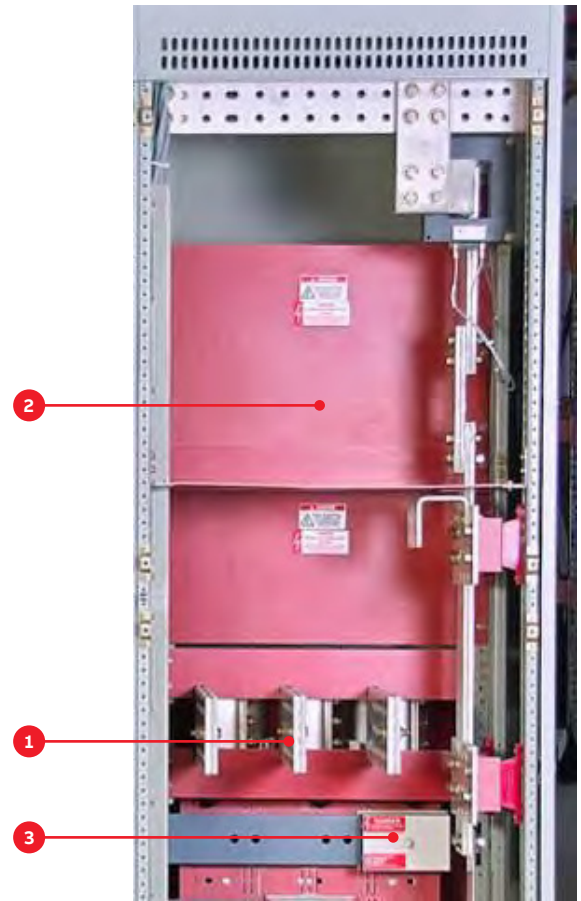

—
Fig. 3.22

1. Incoming cable connection
2. Isolation barriers
3. Main horizontal bus connections

—
Fig. 3.23
Insulated/isolated-
bus system

—
Fig. 3.24
Transition section

Insulated/isolated bus system

A bus insulation system, Fig. 3.23, that fully insulates and isolates each phase of the horizontal main bus and isolates each phase of the vertical bus, is optionally available for AKD-20 and Entellisys switchgear when specified. With the INSULATED/ISOLATED BUS system, there are no live connections accessible in the rear of each section except the cable lugs.

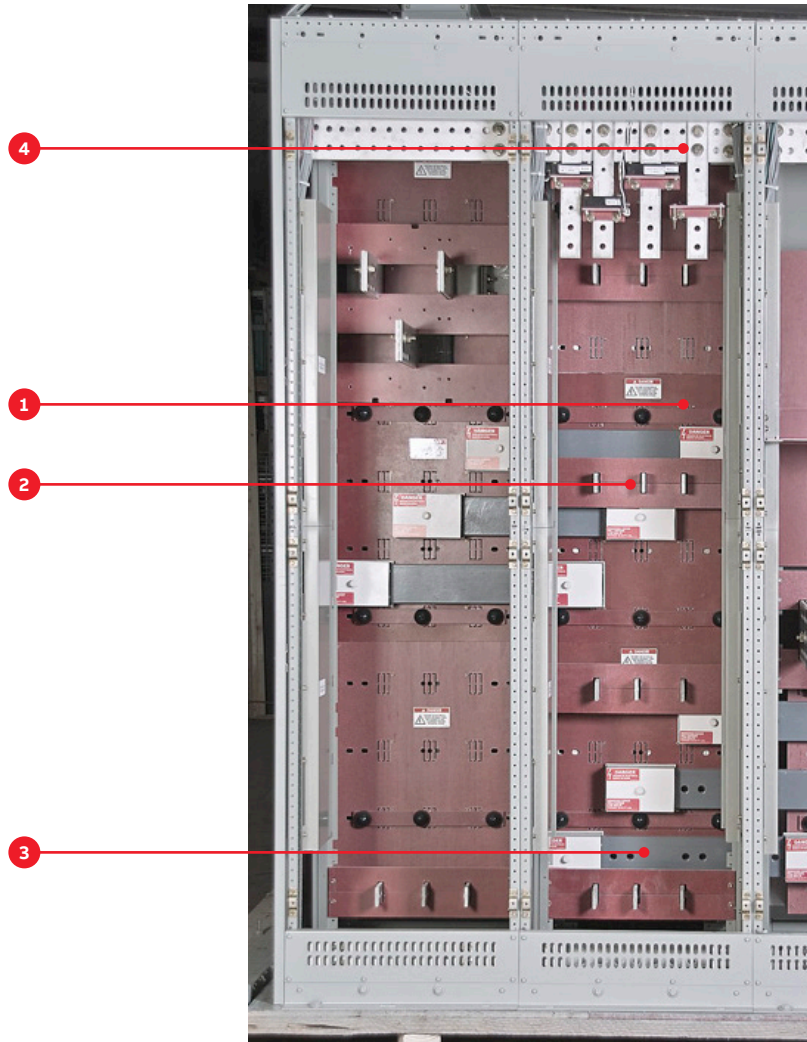

—
Fig. 3.23

1. Vertical riser bus covers
2. Run-backs to feeder cables
3. Horizontal main bus
4. Upper neutral bus with 4th wire sensors

A vertical barrier, Fig. 3.24, between the transition section and the first breaker section is always furnished. The buswork in the device/auxiliary/transition sections is not insulated at the termination points to the other connected equipment such as transformers, busway, or existing equipment.

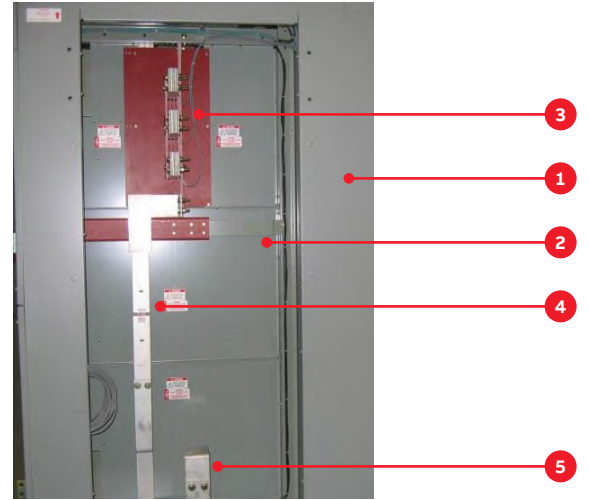

—
Fig. 3.24

1. Transition compartment
2. Barrier
3. Main incoming bus
4. Neutral bus
5. Ground bus

Insulation and isolation of the vertical riser bus bars, Fig. 3.25, is provided by installing phase isolation barriers (not shown) between the bus bars and by the vertical bus barrier which covers over the bus bars.

The phase isolation barriers and riser bus covers are constructed from insulating material. Insulation of the horizontal main bus bars is achieved by an oven cured coating of epoxy.

The vertical/ horizontal bus bar joints are covered with collars and caps (Joint Cap) held in place with nylon thumb screws. The collars and caps are constructed from insulating material.

—
Fig. 3.25
Bus system

—
Fig. 3.26
Insulated horizontal
bus system

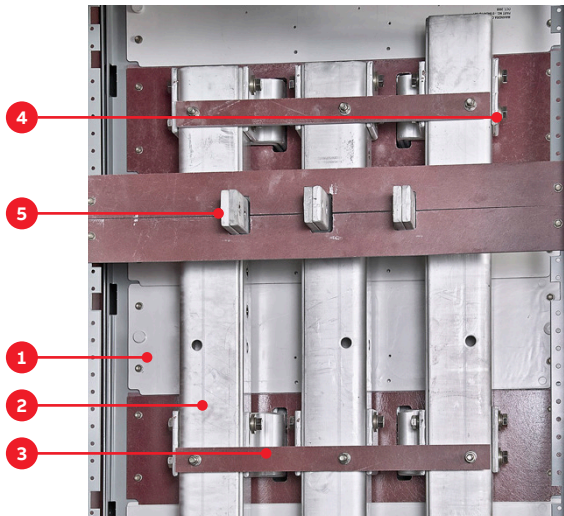

—
Fig. 3.25

1. Molded base
2. Vertical riser buses
(cover removed to show bus location)
3. Vertical bus bracing
4. Run in conductors
5. Insulated run backs

Figure 3.26 illustrates the various components comprising the vertical main bus bars. Bus bars are supported by molded or machined barriers. Vertical bus can be braced depending on the interrupting rating of the switchgear. Conductors that provide current to the breaker compartments are called run in bars and are bolted to the riser bus bars. Insulated run back bars are for connecting load conductor cabling.

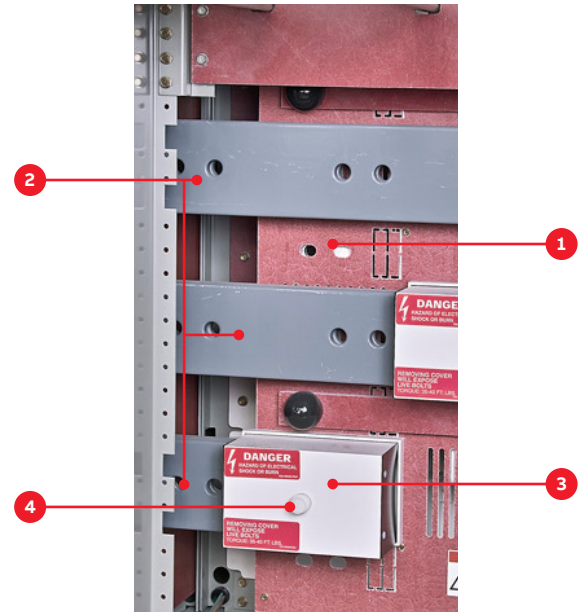

—
Fig. 3.26

1. Vertical bus barrier
2. Insulated bus bar (epoxy coated)
3. Joint cap
4. Nylon thumb screw

—
Fig. 3.27
Cable termination
provisions

—
Fig. 3.28
Control wiring
termination trough

3.12 Feeder cable and busway

The rear cable and terminal compartment, Fig. 3.27, provides for cable installation and terminations. The cable bending space meets the requirements of the National Electric Code. Various arrangements of single or double cable terminals are provided, depending upon the purchaser's requirements.

When specified, racks for the support of feeder cables are located in the cable compartment. The actual support of the cables is provided by lashing them to these racks.

Also located in the cable compartments are provisions for terminating control wires between external devices and control circuits within the switchgear equipment. Figure 3.28 shows this typical arrangement.



—
Fig. 3.27

1. Cable lugs (mechanical type)

When furnished, the terminal boards, Fig. 3.28, for such connections are located in an enclosed vertical wiring trough mounted on the side of the cable compartment. The trough is of steel construction with bolted covers to provide an isolation barrier between the control wiring and the adjacent power cables.

A neutral bus, insulated from ground, is provided in the bus area on switchgear designed for four-wire systems. The neutral bus is located either near the top or near the bottom of the cable compartment. It includes provisions for terminating the neutral conductor of four-wire feeder cables and also direct mounting of the neutral CT or neutral Rogowski as required for those feeder system circuit breakers having a ground fault trip function.

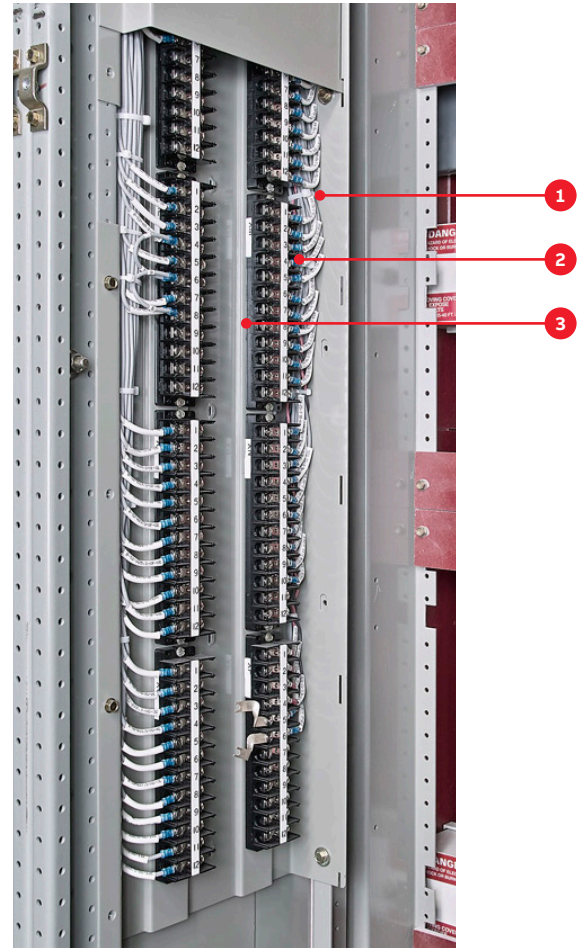

—
Fig. 3.28

1. Internal equipment control wiring
2. Terminal boards
3. Space for purchaser's field control wiring

—
Fig. 3.29
Cable termination
compartment

—
Fig. 3.30
Switchgear outdoor
enclosure

3.13 Ground bus

All AKD-20 and Entellisys switchgear sections are grounded to the internal equipment ground bus, Fig. 3.29, located at the bottom or the top of the cable compartment.

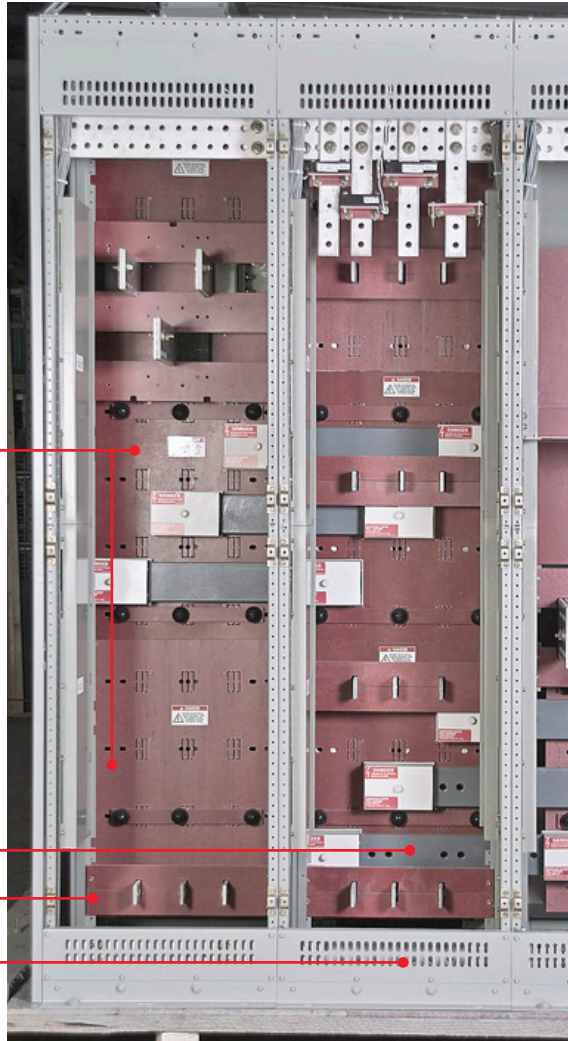

Fig. 3.29

1. Feeder run backs
2. Vertical riser bus covers
3. Horizontal main bus
4. Ground bus (behind steel cover)

3.14 Outdoor switchgear

Switchgear designed for outdoor installations is fully weatherproofed. See Fig. 3.30. A weatherproof housing completely encloses the switchgear and may be provided with a walk-in front aisle for easy access to all controls and instruments.

Aisle lighting with wall switch, Fig. 3.30 and a 115-volt GFCI convenience outlet are standard devices supplied with front aisle, outdoor switchgear equipment. Also included in the walk-in front aisle area are the breaker-lifting device and storage provision for the breaker lifting device operating crank as shown in Fig. 3.30.

A double-wide door with panic latch is provided for breaker loading.

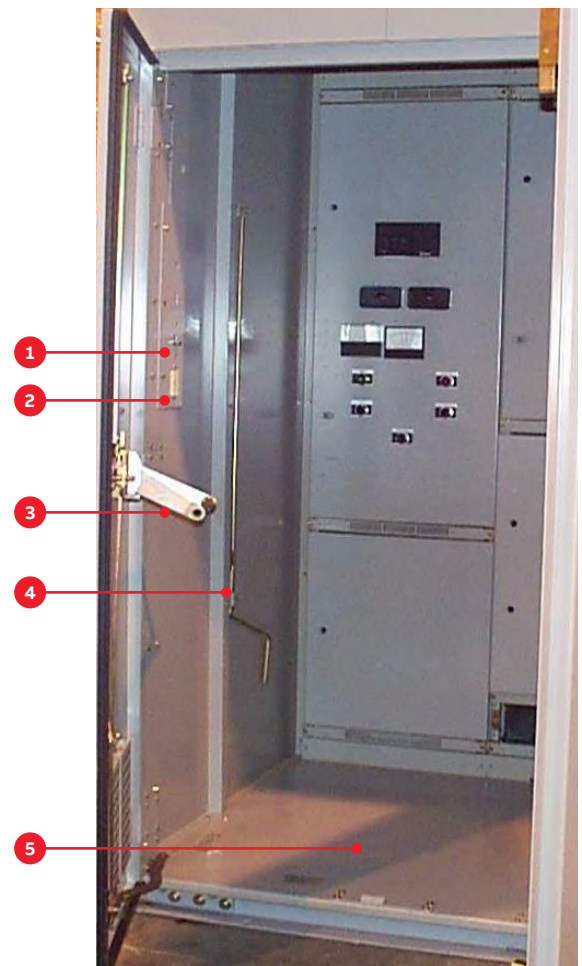

Fig. 3.30

1. Interior lighting switch
2. GFCI convenience outlet
3. Panic latch
4. Breaker lifting device crank
5. Walk-in aisle - 46 inches deep (approx.)

Space heaters, Fig. 3.31 are provided as standard equipment. They provide protection against condensation of moisture that could, in combination with air-borne contaminants, deteriorate insulation or cause corrosion.

One 1000-watt, 240-volt, operating at 120V (250-watts) AC heater is located on the floor of the bus compartment of each outdoor switchgear section. The heaters should be energized at all times to prevent condensation within the switchgear.

Heaters are fed by the control power transformer. The on-off control switch is located in the walk-in front aisle.

Fig. 3.31
Location of space heater
(indoor enclosure)

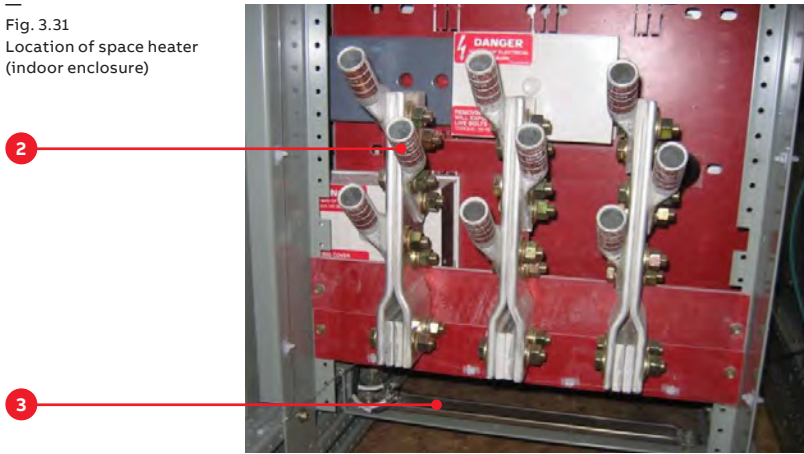

1. Rear cable compartment floor (standard on outdoor - optional on indoor) (not shown)
2. Run backs and cable lugs (compression type)
3. Space heater

Outdoor switchgear may also be provided without the walk-in front aisle. Non-walk-in outdoor equipment is not equipped with an overhead breaker lifting device. A portable breaker lifting device, available as an optional accessory, is used for lifting the EntelliGuard breakers.

4. Equipment installation

4.1 General

This section contains complete instructions for installing AKD-20 and Entellisys low voltage switchgear.



Caution: Personnel installing this equipment must be thoroughly familiar with this instruction manual and all articles of the National Electrical Code applicable to the installation of this switchgear. In addition, all drawings, both mechanical installation and electrical, must be understood and strictly followed to prevent damage to the switchgear or equipment being protected by the switchgear.

Prudence: Le personnel installant cet équipement doit parfaitement connaître ce manuel d'instructions, ainsi que tous les articles du Code national électrique des États-Unis applicables à l'installation de cet appareillage électrique. En outre, ce personnel doit bien comprendre et suivre à la lettre tous les dessins, mécaniques et électriques, afin d'éviter d'endommager l'appareillage ou l'équipement protégé par l'appareillage.



Note: Before installation work is started, it is important to review all of the drawings provided, including the equipment arrangement drawings, site installation drawings, elementary and remote connection drawings, mechanical connection drawings, and the summary of equipment list.

Remarque: Avant de commencer la procédure d'installation, il est important de passer en revue tous les dessins fournis, notamment les dessins d'organisation de l'équipement, les dessins pour l'installation sur site, les dessins des connexions élémentaires et distantes, les dessins des connexions mécaniques, ainsi que le récapitulatif de la liste des équipements.

All expendable hardware for shipping purposes only, is painted yellow or tagged with yellow adhesive tape and may be discarded at completion of the installation phase.

Site location

In general, the location of the switchgear equipment will have been predetermined during the specification and/or procurement of equipment phases. Indoor locations within buildings impose certain requirements which must be met so that the switchgear may operate efficiently with a minimum of maintenance.

In locating the switchgear, adequate aisle space must be provided at the front and rear of the equipment to ensure proper ventilation of the equipment and to allow service and maintenance of the equipment with the front and rear doors open. The recommended aisle space is shown on the floor plan supplied with the equipment drawings.

The switchgear equipment should be placed in an area where clean, dry air is free to circulate around and above it. Since air is taken into the equipment at the bottom of each section and exhausted at the top, a location with good airflow must be provided for efficient operation. A minimum of 30 inches of clear space above the equipment is recommended.

Foundation requirements

For optimum performance of your switchgear equipment, the foundation requirements expressed in this section should be strictly adhered to.



Note: The foundation for the outdoor switchgear must provide proper drainage of ground and/or surface water accumulations away from the equipment.

Remarque: La base sur laquelle repose l'appareillage électrique extérieur doit offrir un drainage approprié des accumulations d'eau dans le sol et/ou en surface, à l'écart de l'équipement.

The foundation must be strong enough to prevent sagging due to the weight of the switchgear structure and to withstand the shock stress caused by the opening of the breakers under fault conditions. The shock loading is approximately 1-1/2 times the static load. The foundation must be flat and level in all planes. Refer to Fig. 4.1 for definition of flat and level.

Foundation preparation - indoor equipment

Refer to Fig. 4-2 along with the owner's foundation construction drawings and the supplemental installation drawings. Although the indoor switchgear equipment can be mounted directly on a smooth, level floor, it is recommended that recessed steel channels be installed for supporting the equipment. Anchor bolts and channels are to be provided by the purchaser.



Note: When the equipment is installed on a surface subject to impact (shock) loads due to operating conditions or environmental seismic (earthquake) conditions, the anchor bolts should be fabricated of medium carbon steel (grade 5 load rating).

Remarque: Lorsque l'équipement est installé sur une surface susceptible de subir des charges dynamiques dues aux conditions de fonctionnement ou de l'environnement (séismes), les boulons d'ancrage doivent être en acier dur (charge dynamique de niveau 5).

Fig. 4.1
Definition of flat
and level

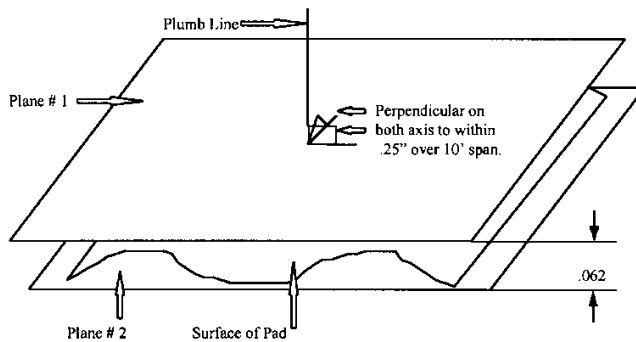

The floor channels under the front and rear switchgear anchor points (see Fig. 4.2) should be embedded in a level concrete slab with their top surfaces flush with the finished floor. It is essential that these steel channels be level and aligned with each other prior to final anchoring, to prevent distortion of the switchgear structure, to assure proper mechanical and electrical connections between shipping splits, and to assure proper interfacing to other close-coupled equipment.

ABB switchgear and load center substations are frequently mounted on steel floors and/or structural steel in industrial installations (such as a mezzanine) to minimize usage of production floor space.

Regardless of the type of mounting surface, the requirement for a smooth level surface remains. If studs or anchor bolts are to be used, they should be installed in the foundation as it is poured. It is important that the studs or bolts are spaced to agree with dimensions given on the job drawings. The dimensions between anchor bolts for a particular installation are dependent upon the configuration of equipment ordered. The dimensions shown on Fig. 4.2 cover the entire standard enclosures available for AKD-20 and Entellisys switchgear.

Fig. 4.3 illustrates the space available for conduit and/or cable entrance through the bottom or top of each equipment section. The space required for control wiring entry to the optional wiring trough is also shown.

Fig. 4.2
Indoor enclosure
anchor locations

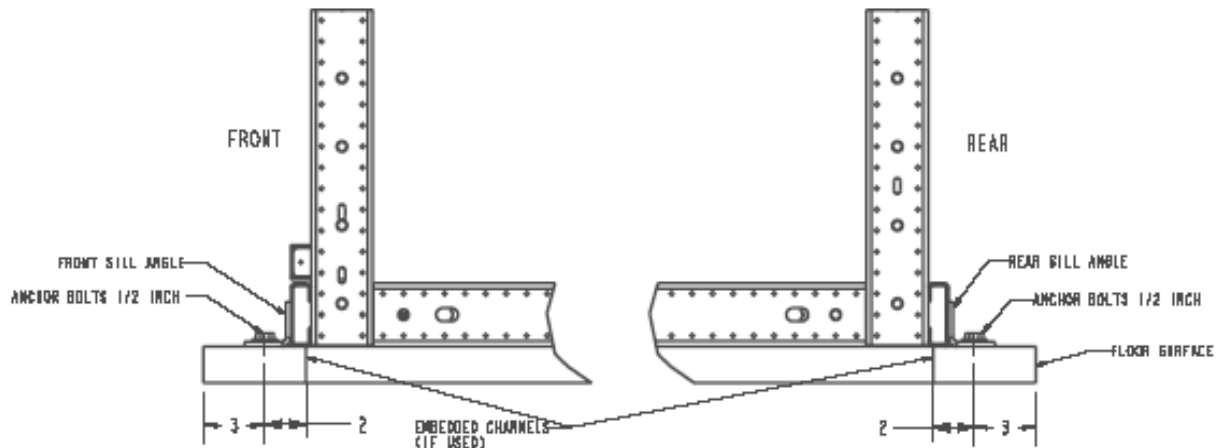

Embedded "C" Channel, if used

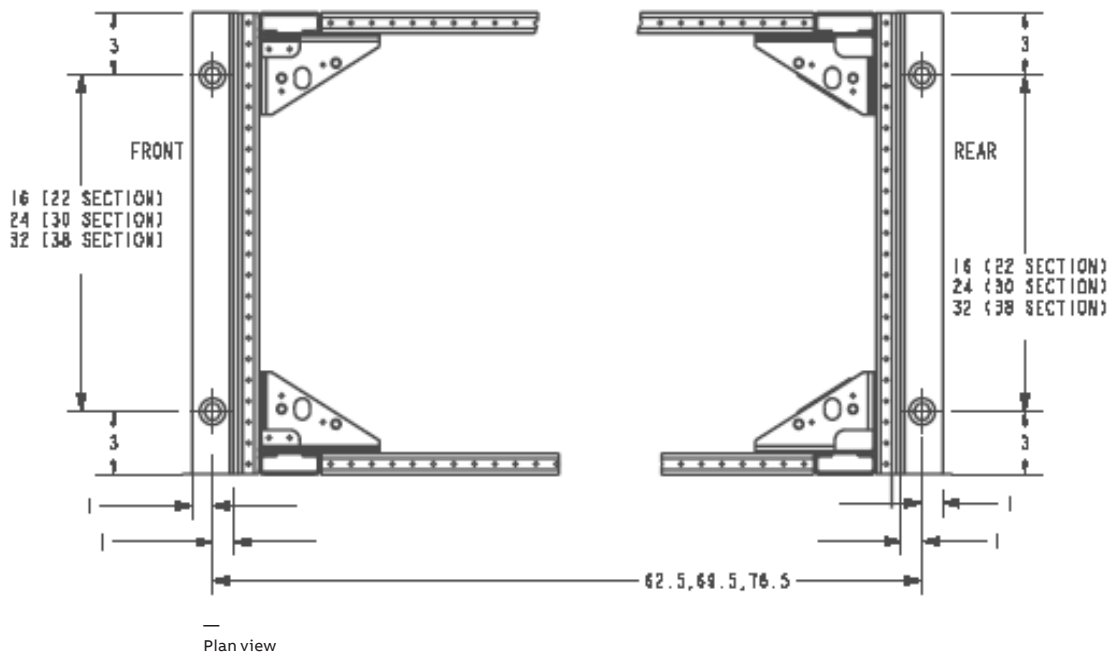

Plan view

Fig. 4.3
Floor plan and cable entry
space (indoor enclosure)

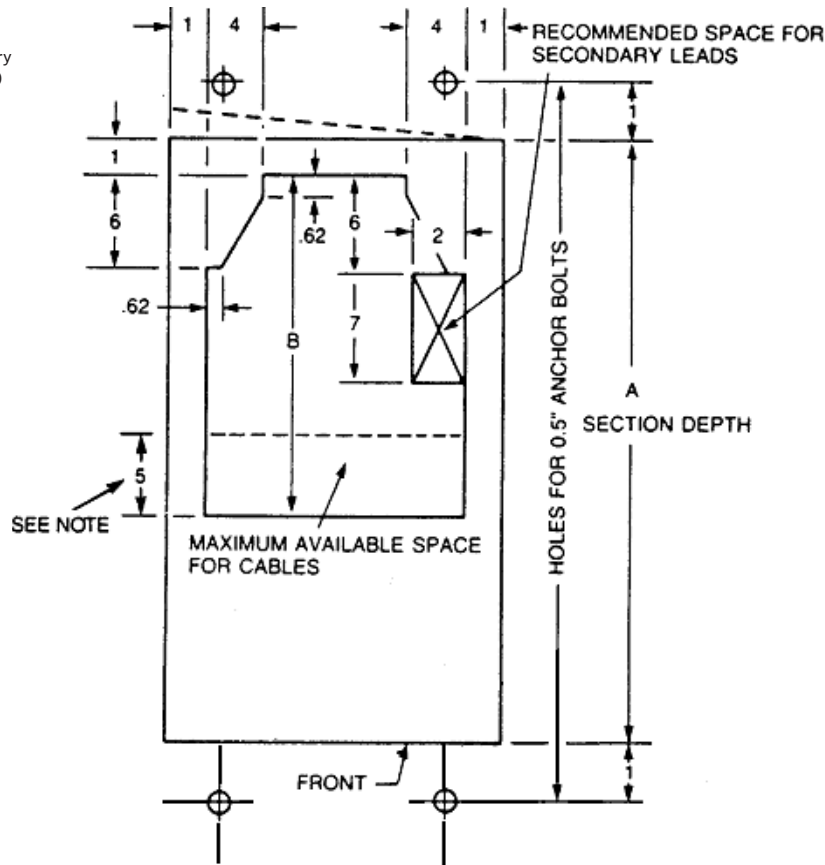

Note: Bus compartment barrier location. When this optional feature is provided, it will reduce the available cable entry space by (5) inches.

Equipment Depth "A" (inches)	Direction of Cables	"B" (inches)
54	Below	19
	Above	24
60	Below	25
	Above	30
67	Below	32
	Above	37
74	Below	39
	Above	44

All dimensions are in inches.

Outdoor equipment

Refer to Fig. 4.4 along with the owner’s foundation construction drawings and the supplemental installation drawings. The outdoor switchgear equipment is supplied with three built-in structural support channels in the base of the switchgear as shown in Fig. 4.4. The front and rear structural support channels are designed to be clamped to the foundation.

The center channel is a structural stabilization channel. Although the equipment can be mounted directly on a smooth, level surface, it is recommended that recessed steel channels be installed to support the switch-gear. The floor channel sills under the front, center, and rear of the switchgear base should be embedded in a level concrete slab with their top surfaces flush with the finished floor.



Note: Four (4) clamp plates are required for each outdoor lineup. One clamp plate located at each corner of the equipment.

While the equipment base center channel is not anchored to the foundation, it is still required that the center channel sill (see Fig. 4.4) be level with the foundation and also with the front and rear channel sills to prevent structural distortion of the switchgear equipment. Only four anchor bolts are normally used for outdoor enclosures.

Depth of indoor switchgear "A"	Depth of outdoor switchgear "B"	Anchor bolt spacing "C"	Sub base depth "D"
60	107.62	106.00	104.62
74	121.62	120.00	118.62

All dimensions are in inches.

Fig. 4.4
Outdoor walk-in enclosure anchor locations

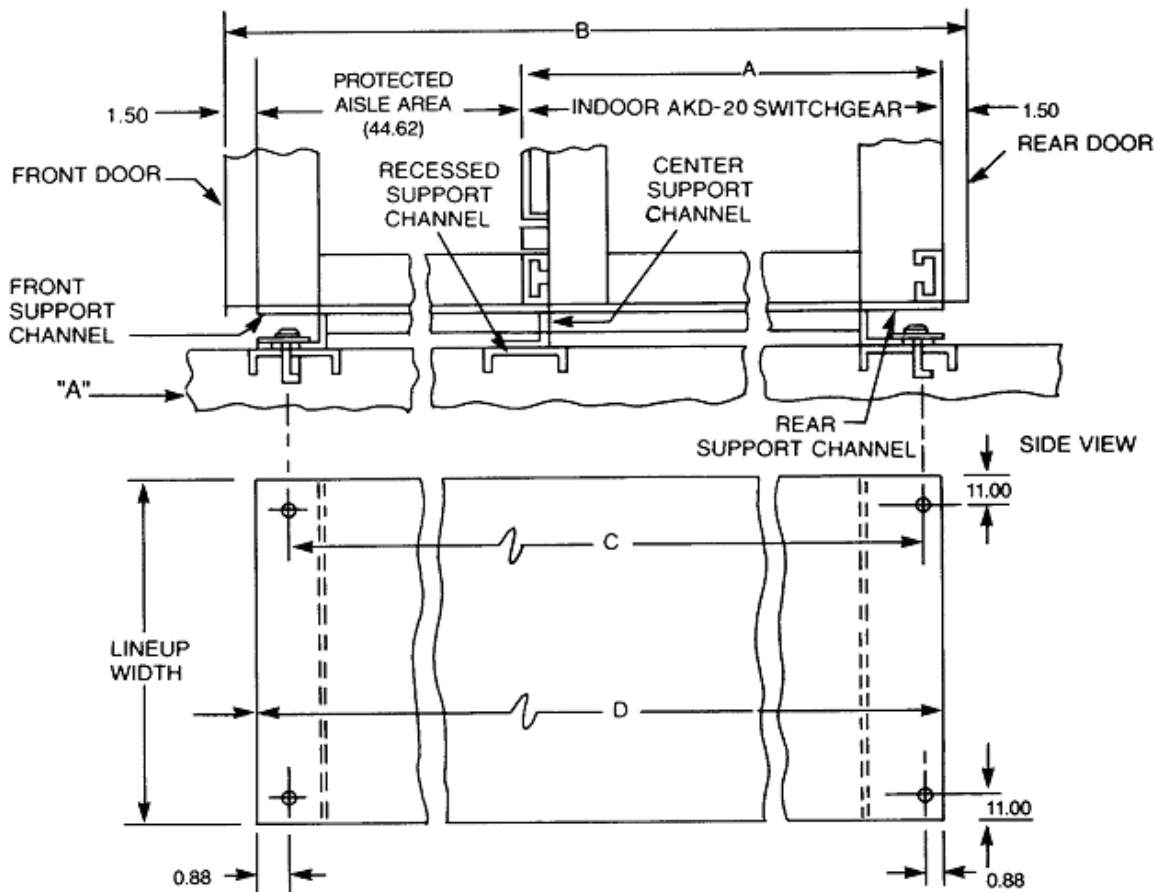

Plan view at level "A"



Note: The factory must be consulted for anchoring recommendations for equipment subject to operational and/or environmental (seismic) shock loading.

Remarque: Veuillez consulter le fabricant pour connaître les recommandations d'ancrage de l'équipement en fonction de la charge dynamique opérationnelle et/ou environnementale (sismique).

Refer to Fig. 4.2 along with the owner's foundation construction drawings and the supplemental installation drawings. Although the indoor switchgear equipment can be mounted directly on a smooth, level floor, it is recommended that recessed steel channels be installed for supporting the equipment. Anchor bolts and channels are to be provided by the purchaser.

Fig. 4.5
Outdoor enclosure
clamp plate

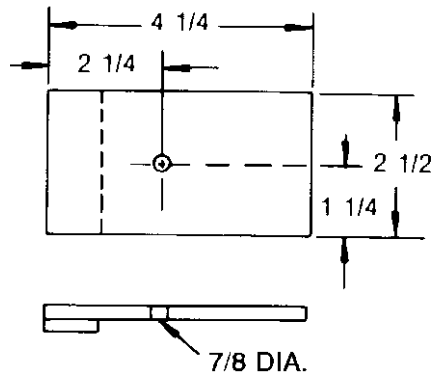

Dimension in inches

4.2 Assembly and installation of switchgear equipment

General requirements

Before assembling or installing the switchgear equipment, all components should be available at the site location. This will facilitate switchgear component identification as well as installation. The foundation should be prepared in accordance with the instructions in Sections 4.1 and 4.2, and all embedded conduits installed and capped.



Note: If rollers are to be used for movement of the equipment to its permanent installation, it is recommended that the shipping skid not be removed until the equipment is placed in position over the anchor bolts.

Remarque: Si vous utilisez des rouleaux pour déplacer l'équipement jusqu'à son emplacement d'installation définitif, nous vous conseillons de ne pas retirer les cales d'expédition tant que l'équipement n'est pas placé au-dessus des boulons d'ancrage.

If a transformer is not part of the installation, and/or the equipment has been split for shipment, place the center section on the foundation first. Assemble the remaining sections outward from the center section, in each direction.

If the switchgear equipment is part of a load center unit substation, the transformer section should be set on its pad first in accordance with the instructions furnished with the transformer. All remaining sections of the switchgear should then be installed.



Note: Before assembling and installing the switchgear equipment, the foundation must be absolutely level and clear of debris to prevent damage and possible misoperation of the switchgear equipment.

Remarque: Avant le montage et l'installation des équipements de commutation, la fondation doit être absolument niveau et exempt de débris pour prévenir les dommages et possible mauvais fonctionnement de l'équipement.

—
Fig. 4.6
Lifting plate location

Detailed assembly and installation instructions indoor equipment

The recommended procedure for installation of an indoor switchgear or load center unit substation is as follows:

1. Position the equipment - Position the equipment or sections of the complete equipment in their final location.



—
Fig. 4.6

1. Indoor Lifting Plates



Note: If the equipment line-up was split into shipping sections, the lifting plates on corners of adjacent sections shown in Fig. 4.6 must be removed. Failure to remove these plates will interfere with mating adjacent sections and prevent installation of bus splice plates, structure tie plates, etc.

Remarque: Si l'équipement a été divisé en plusieurs sections pour l'expédition, les plaques de levage au niveau des angles des sections adjacentes indiquées sur la Fig. 4.6 doivent être retirées. Si vous ne retirez pas ces plaques, cela empêchera l'assemblage des sections adjacentes, ainsi que l'installation des plaques d'assemblage du jeu de barres, des plaques d'attache de la structure, etc.

Once the lifting plates have been removed, they may be discarded.



Note: In the event the lifting plates must be reassembled on the equipment for lifting purposes, they must be moved to locations where unused screw holes are available, generally achieved by shifting the plate horizontally on the mounting surface one bolthole from its previous location. When remounting the lifting plates, torque the mounting bolts to 7-9 ft-lbs.

Remarque: Si les plaques de levage doivent être réassemblées sur l'équipement pour lever celui-ci, elles doivent être déplacées à des emplacements où des trous de vis non utilisés sont disponible, ce qui est généralement le cas si vous décalez la plaque à l'horizontale sur la surface de montage d'un trou de boulon à partir de son emplacement précédent. Lorsque vous remontez les plaques de levage, tournez les boulons de montage sur 7-9 pieds-livres (9,49- 12,20 Nm).



Note: All mating sections of the equipment line-up (including transformer, if applicable) must be securely fastened together prior to tightening anchor bolts fastening the equipment to the mounting surface.

Remarque: Toutes les sections de l'ensemble de l'équipement (y compris le transformateur, le cas échéant) doivent être solidement fixées les unes aux autres pour que vous puissiez serrer les boulons d'ancrage fixant l'équipement à la surface de montage.

—
Fig. 4.7
View showing method of attaching equipment to shipping skids

2. Remove the shipping skids - The equipment is fastened to the shipping skids with ½ inch lag screws through the equipment anchoring holes. See Fig. 4.7.

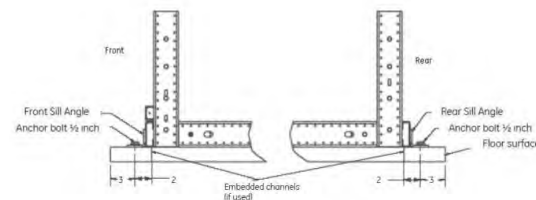

—
Fig. 4.7

Equipment shipping sections up to 10 feet long will be fastened to the skids with four lag screws, one in each corner. The shipping skid and lag screws are expendable material and may be disposed of at the purchaser's discretion.

—
Fig. 4.8
Location of through-bolts (dimension in inches)

3. Fasten section together - After placement of the equipment and installing the anchor bolts loosely, the various shipping sections must be rigidly fastened together. Throughbolts fasten each section of the switchgear equipment to the adjacent section. Fig. 4.8 shows the location of the throughbolts

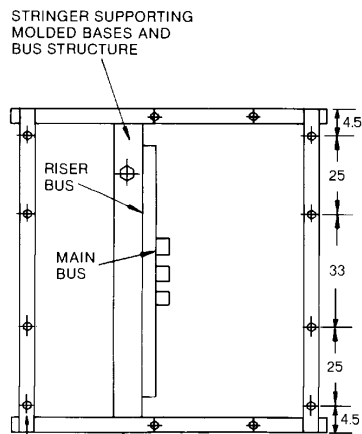

—
Fig. 4.8

Fig. 4.9 illustrates the installation of the throughbolts. The throughbolts are in the front and rear compartments. The nut and bolt assembly should be tightened with a torque of 25–30 ft-lbs.

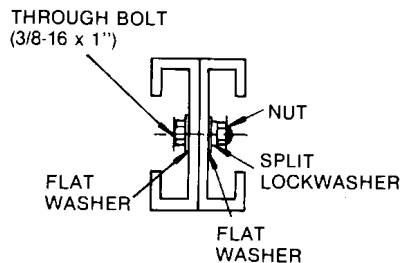

—
Fig. 4.9

All of the hardware required for assembling the equipment across the shipping splits is furnished with the equipment. If a transformer is included in the line-up of equipment, the transformer flange should be aligned with the opening in the side of the transition section and fastened together using the 3/8-16 bolts, nuts and washers supplied with switchgear. The fastener assembly should be tightened with a torque of 25-30 ft-lbs.

4. Complete the electrical interconnections - After completing the mechanical connections between the several sections of equipment, the electrical interconnections should be completed. This includes the installation of splice plates for the main bus bars, the neutral bus, and the ground bus in addition to the control and metering circuits.

Warning: All switchgear equipment must be adequately grounded for safety. Failure to ground equipment properly may result in serious injury.

Avertissement: Pour des raisons de sécurité, tout l'équipement de l'appareillage électrique doit être correctement mis à la terre. Faute de cela, il existe un risque important de blessures graves.

Fig. 4.10 illustrates the general location of the buses that must be spliced across the shipping splits.

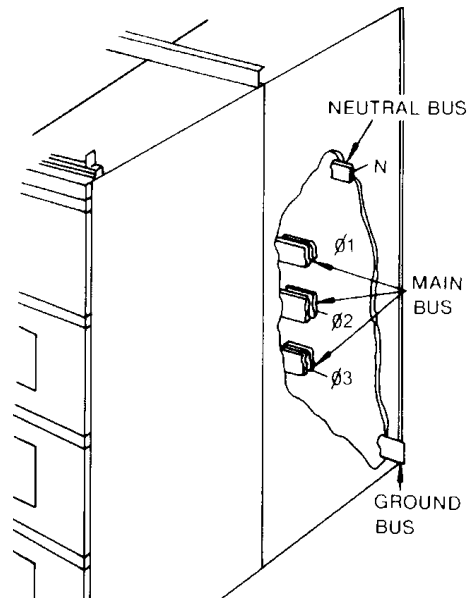

—
Fig. 4.10

—
Fig. 4.11
Plan view of ground
bus splice installation

—
Fig. 4.12
Flange opening on a
transition section to
a GE transformer

Ground bus

The ground bus is mounted directly on the rear upright channels in each individual section.



Note: It is particularly important that the ground bus be connected first since it provides an integral ground for all the equipment. It must also be connected to the station ground prior to proceeding with the installation.

Remarque: Il est particulièrement important que le jeu de barres de mise à la terre soit connecté en premier car il fournit une mise à terre intégrale pour l'ensemble de l'équipement. Il doit également être relié au sol avant le début de l'installation.

A 4/0 AWG cable connector is located in the bottom of the transition section (or in the incoming line compartment if a transition section is not included) for terminating the purchaser's cable connection to ground. The specific location of the station ground connection is shown on the site floor plan drawing and in the electrical drawings supplied with the equipment. All grounding of the switchgear should be in accordance with National Electrical Code.

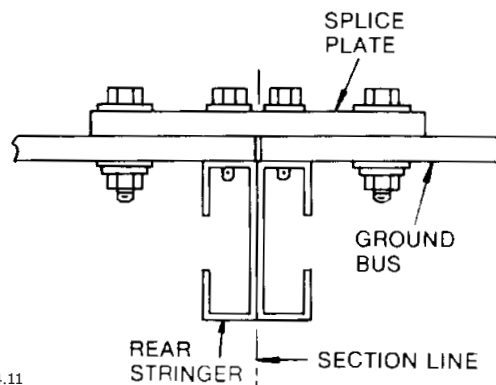

—
Fig. 4.11

Fig. 4.11 illustrates the installation of the ground bus splice plate across a shipping split. In addition to the bolted fastening of the splice plate to the two ends of the ground bus, self-tapping 1/4-20 bolts pass through the splice plate and ground bus stubs, and thread into the equipment frame. These bolts should be fastened with a torque of 7–9 ft-lbs.

If a transformer (rated above 750 kVA) is present in the line-up, a ground bar located in the transition compartment, Fig. 4.12, is provided for connection of the transformer ground pad to the equipment ground termination point.

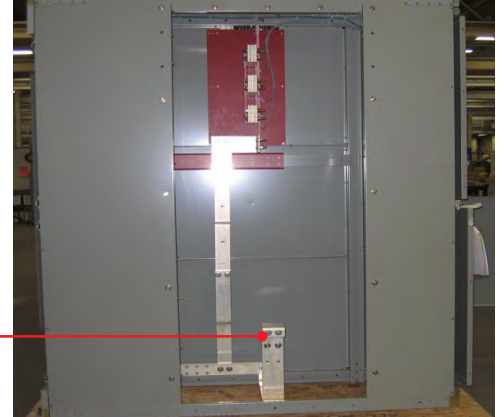

—
Fig. 4.12

1. Ground bus

As shipped, the ground bar is mounted so it does not protrude beyond the outer surface of the equipment. When the equipment is installed in its final location, the ground bar must be reassembled using the outer bolt holes in the horizontal ground bus spanning the width of the transition compartment. In this mounting location, the offset portion of the ground bar will permit connection to the transformer ground pad with the 1/2-13 bolt assembly supplied with the switchgear equipment. If an optional floor plate is supplied for the transition compartment, it will be necessary to remove the floor plate to permit relocation of the ground connection bar.

All bolted bus joints should be made using the proper torque as shown in Table A.1 in Appendix A of this manual. Transformers not manufactured by ABB may require special mounting and bus connection hardware.

—
Fig. 4.13
Plan view of neutral
bus splice installation

—
Fig. 4.14
Rear view of main bus
at a shipping split

—
Fig. 4.15
Plan view of a three bar
main bus connection

Neutral bus

The neutral bus may be insulated from the grounded frame of the switchgear equipment; thus, it is mounted on insulators throughout the equipment.

Installation of the neutral bus splice plate across a shipping split is similar to the ground bar splice except that the splice plate is not bolted to the equipment frame. Fig. 4.13 illustrates the installation of the neutral splice plate.

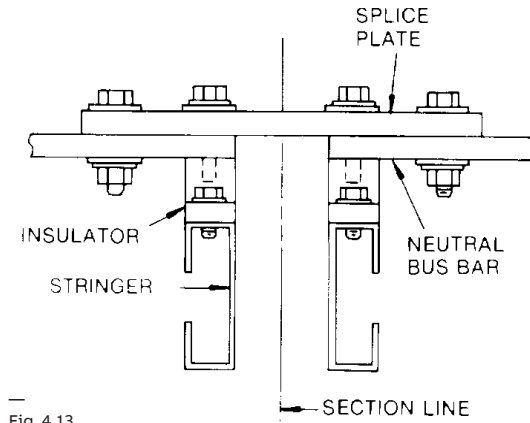

—
Fig. 4.13

Horizontal main bus

The installation of the horizontal bus splice bars is with bolted joints. Figs. 4.14 and 4.15 illustrate the assembly of the main bus splice plates on the bolted bus system. Copper bus systems are normally supplied with flat washers and lock washers.

Fig. 4.14 shows the rear view of the main bus area with the installed splice plates indicated with cross-hatching.

Fig. 4.15 shows that a spacer is used both between the bus bars when more than one bar is used per phase (normally the 2500 ampere and larger main bus ratings).

After assembly of the splice bars and spacers, the 1/2-13 bolts should be tightened to a torque of 35-40 ft-lbs. After completing the installation of the main bus splice bars, the joint covers may be mounted and secured by a 3/8-16 nylon bolt and polyester flat washer if the bus insulation option has been supplied with the equipment.

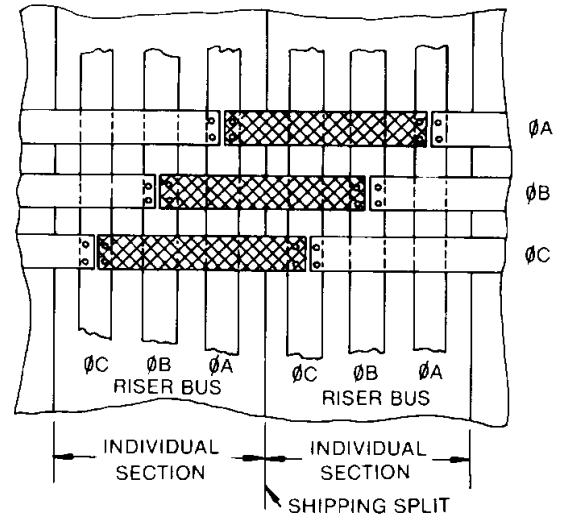

—
Fig. 4.14

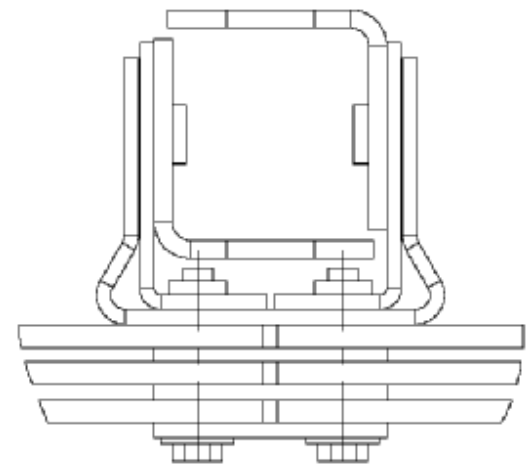

—
Fig. 4.15

—
Fig. 4.16
Interconnect
control wiring

5. Connect the transformer secondary - The connection of the transformer secondary to the incoming bus bars in the transition is made using the flexible connection straps supplied with the transformer. These connections are always bolted joints.

The recommended torque for tightening the ½-13 bolts fastening the transformer connection straps to the incoming bus bars is 35-40 ftlbs.

Interconnect control wiring

Interconnect control wiring is located in the wire trough at the top front side of the equipment and runs the length of the lineup.

6. Interconnect control wiring - Interconnection of control wiring across shipping splits is accomplished by connecting to terminal blocks located in the cross-section wiring trough on top of the equipment shown in Fig. 4.16.

If terminal blocks are provided, each wire must be attached to the correct point on the terminal block, following the circuit identification number attached to each wire.

Ethernet or other communication wiring is connected by similar methods.



—
Fig. 4.16

Outdoor equipment

The recommended procedure for installing switchgear supplied in an outdoor enclosure is as follows:

1. Position the equipment - Position the equipment or sections of equipment in their final location. If the equipment line-up was split into two or more shipping sections, it is necessary to first match, line up, and reassemble the multiple sections into an integrated equipment assembly.
2. Apply gasket material - After removal of the lifting plates (see Fig. 2.4), it is necessary to apply the presstite gasket material, Figs. 4.17 and 4.18, to the mounting surface of the roof flange. The gasket material is supplied with the equipment.

3. Align sections - Align the two sections with the mating surfaces butted together.

4. Fasten sections together - Referring to Fig. 4.17, the mating sections of the outdoor enclosure should be immediately bolted together including the front and rear vertical posts and the roof flange. Each vertical post will require ten 3/8-16 x 1-inch bolt assemblies, see Fig. 4.19; the roof flange will require either eleven or twelve 1/4-20 x 1/2-inch thread forming bolts. The bolts should be tightened with a torque of 7-9 ft-lbs. Fig. 4.18 is a cross-sectional view of the assembled roof joint.

Fig. 4.17
Outdoor enclosure
shipping split assembly

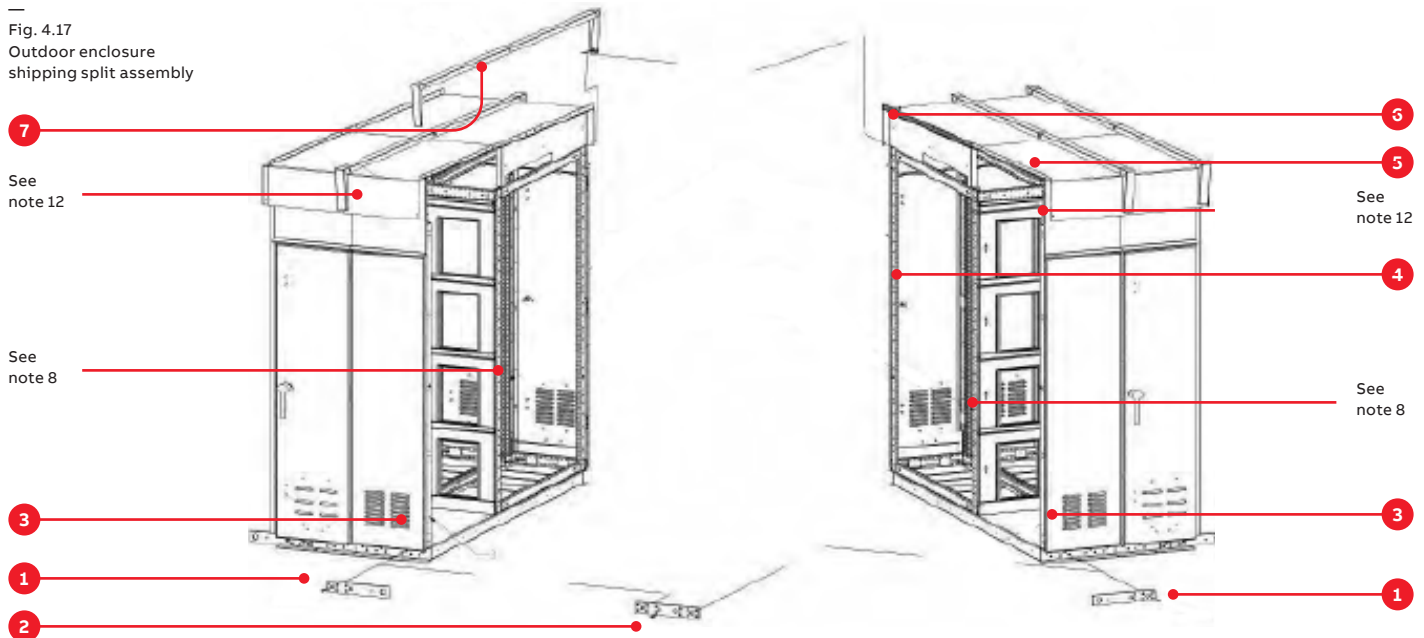

1. Lifting plates (quantity of (4) per shipping split; rear plates not shown)
2. Splice plates
3. Front vertical post
4. Rear vertical post
5. Roof flange
6. Gasket
7. Roof cap

—
Fig. 4.18
Cross-section view of
assembled roof joint

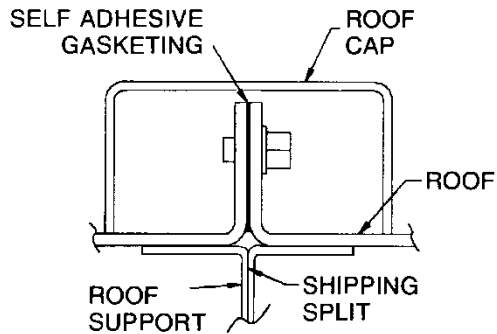

—
Fig. 4.18

5. Tie housing bases together - Referring to Fig. 4.17, tie the bases of the outdoor housing together using the splice plate supplied with the equipment and the bolts which previously secured the lifting plates removed after emplacement of the equipment. The nuts are welded to the rear surface of the base. The bolts should be tightened with a torque of 45 ft-lbs.



Note: There are two splice plates required, front and rear of the assembly.

Remarque: Deux plaques d'assemblage sont nécessaire, à l'avant et à l'arrière de l'équipement.

6. Install the roofcap - The roof cap, Fig. 4.17, should be installed over the sealed and fastened roof flange assembly. The roof cap is secured in place with two 1/4-20 NC x 1/2-inch thread forming bolts, each at the front and the rear ends of the roof cap. These bolts should be tightened with a torque of 7-9 ft-lbs.
7. Connect transformer flange - If a transformer is included in the equipment line-up, the flange should be connected to the switchgear opening using the gasket and fastening material supplied with the switchgear equipment.
8. Join sections together - The switchgear equipment within the outdoor enclosure should be joined to its mating sections in the manner described for indoor equipment in Section 4, Step 3 referenced on page 32.

9. Make electrical interconnections -
The installation of bus splice plates for the main horizontal, neutral and ground buses should be done in accordance with the instructions for indoor equipment, Section 4, Step 4, referenced on page 33.
10. Connect the transformer secondary -
The installation of the transformer connection straps to the incoming bus should be done in accordance with the instructions for indoor equipment, Section 4, Step 5, referenced on page 35.
11. Interconnect control wiring -
The interconnection of control wiring across shipping splits should be done in accordance with the instructions for indoor equipment, Section 4, Step 6, referenced on page 35.
12. Seal small openings - After completion of the shipping split assembly, any small openings should be sealed with clear silicone caulking cement.

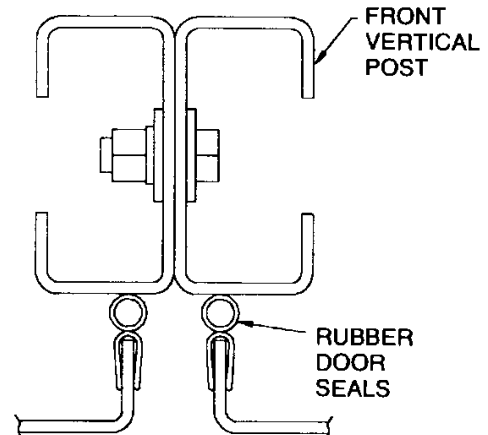

—
Fig. 4.19

Anchoring switchgear equipment

Correct anchoring of the switchgear equipment to the foundation is very important. After completion of re-assembly of the equipment at the shipping splits, the equipment anchoring procedure should be completed.

Indoor equipment

1. Anchoring by anchor bolts - Indoor equipment are normally secured to their final mounting surface by anchor bolts threaded into the embedded channel sills, Fig. 4.20. The bolts were loosely threaded into place before reassembling the equipment shipping splits and connecting to the close-coupled transformer, if appropriate. The anchor bolts should now be tightened with a torque of 35-40 ft-lbs.

2. Anchoring by weld - An alternate method of anchoring the equipment to its foundation is to weld the equipment to floor sills (or the floor itself if constructed of steel). Several methods, shown on Fig. 4.21, are available to the purchaser for welding the equipment to the channel sills.

a. The front of the equipment is attached to the embedded channel sills, Fig. 4.21, by two 3/16-inch fillet welds. It is recommended that two welds, each 2-1/2 inches long (min.), be used for each section to firmly tie the bottom width post to the channel sill.

b. The rear of the equipment may be anchored by one of three procedures:

The first method is by plug welds, Fig. 4.21, using the anchor bolt holes in the rear sill angle. The plug weld should receive a minimum 1/2-inch bead around the entire circumference of the anchor bolt hole.

A second method of securing the front and rear sill angles to the channel sill is the use of two linear fillet welds for each section. It is recommended that each weld be 2-1/2 inches long (min.) with a 3/16-inch fillet (min.).

A third method for anchoring the rear of the equipment is to remove the rear sill angle from the switchgear and weld the rear bottom width post to the channel sill. These welds should, like the front welds, have a 3/16-inch (min.) fillet and each have a minimum length of 2- 1/2 inches.

Outdoor equipment

Outdoor equipment is anchored after re-assembly of the separately shipped sections. The four anchor bolts should be tightened with a torque of 45-55 ft-lbs.



Caution: If the equipment is to be subjected to operational or environmental (seismic) shock loading, the factory must be consulted for anchoring recommendations.

Prudence: Si l'équipement risque d'être soumis à une charge dynamique opérationnelle ou environnementale (sismique), veuillez consulter le fabricant pour connaître les recommandations d'ancrage.

Fig. 4.20
Indoor equipment
anchoring

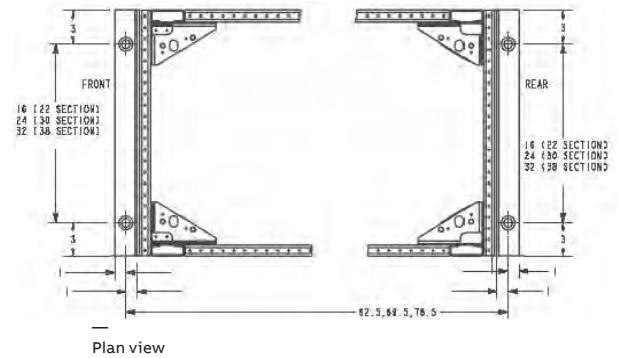
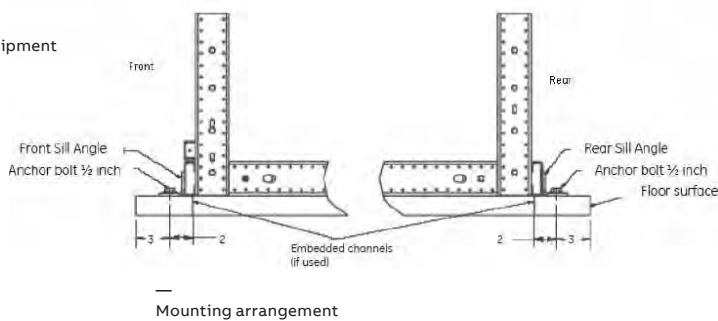
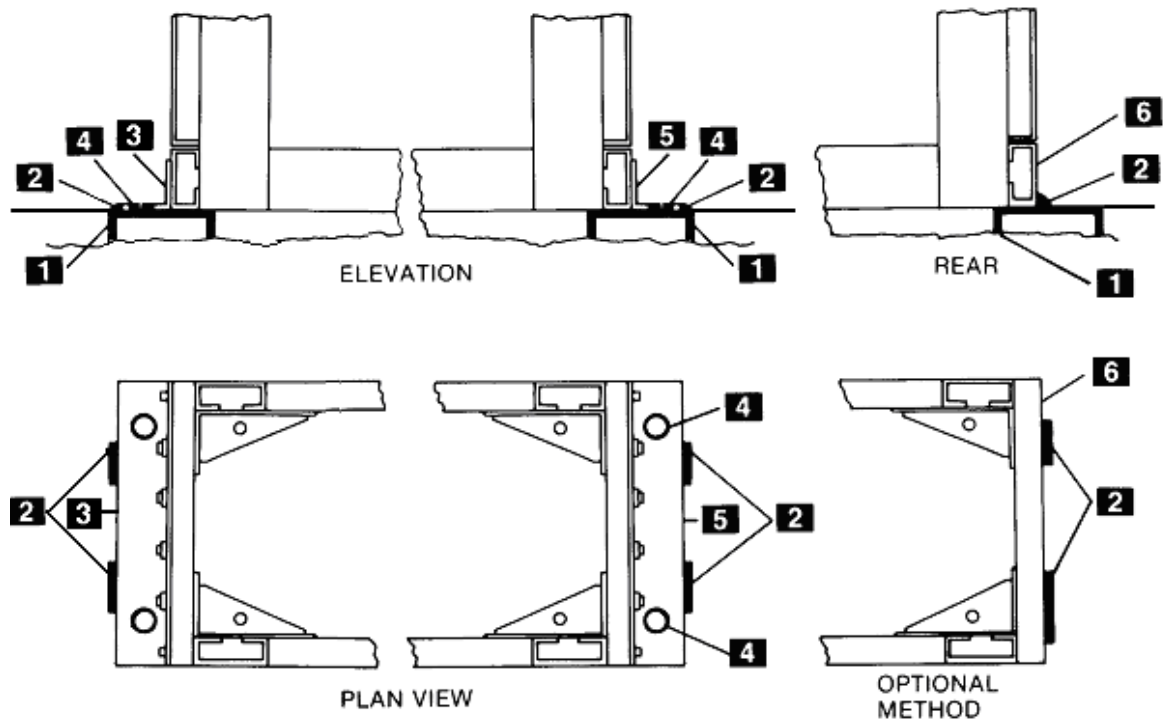

Fig. 4.21
Indoor equipment
weld anchoring



Busway connections

Busway runs must be aligned with openings in the equipment and connected to the mating components electrically and mechanically. A collar is mounted on the top of the equipment cable compartment to which is bolted the busway housing. See Fig. 4.22. The 1/4-20 NC bolts, washers, and nuts for this mechanical connection are supplied with the busway stub. The bolts should be tightened with a torque of 7-9 ft-lbs.

The power conductors in the busway stub are designed to bolt directly to power connector blocks mounted on the switchgear riser bus bars. These connections are made with 1/2-13 NC bolts supplied with the switchgear equipment.



Note: To maintain the minimum contact resistance across bolted bus joints, it is recommended that the joint contact surfaces be coated with a film of lubricating grease. A can of this grease is supplied with the equipment. Do not put grease on the bolt threads as this will affect the clamping force exerted by the bolt.

Fig. 4.22
Spectra series* busway
mounting (front-entry)

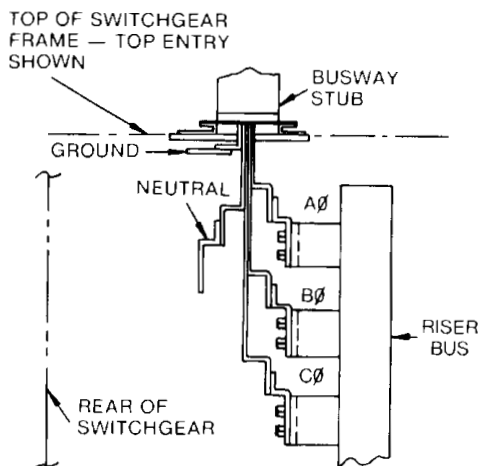

Remarque: Pour conserver la résistance de contact minimale sur les raccordements du jeu de barres boulonné, nous vous conseillons d'enduire les surfaces de contact des raccordements d'un film de graisse, référence. Une boîte de cette graisse est fournie avec l'appareillage. Ne mettez pas de graisse sur le filetage des boulons car cela affecterait la force de serrage exercée.

Control wire connections

For external control wiring, refer to Fig. 4.23 for switchgear cable area dimensions, and connect the control wires to the switchgear sections as follows:

1. When control conduits enter the switchgear from below, they should not extend more than one inch above the floor. The control wires may be pulled through the conduits before or after the switchgear is installed.
2. Route the control wires from the conduits through the wiring trough (cross-hatched area- 2" x 7"-shown on Fig. 4.23) at the side of the cable compartment. Connect the cables to the terminal blocks in accordance with the connection diagrams for the equipment.
3. If the control conduits enter from above, drill the top cover within the available space indicated. See Fig. 4.23. Control wires should be routed to the wiring trough and connected to the terminal blocks as described previously.

Power cable connections

Connect the main cables to the main lugs. Before any main cable connections are made, the cables should be identified to indicate their phase relationship with the equipment. Adequate electrical and mechanical clearances must be provided between conduit, cables, and bus. Where the cables enter the section, they can be lashed to optional cable supports at the rear of the cable compartment as required.

Mechanical cable terminals are normally included with the switchgear (compression terminals are supplied when ordered) and are mounted at the ends of the breaker runbacks in the cable compartment. Carefully follow the cable manufacturer's recommendations for installation of cable.

Install the cables in the proper path to the terminals, using temporary lashing if required. Cut the cables to the proper length. Strip the insulation to the desired dimension, being careful not to damage any strands.

For copper cables, coat the wires with lubricating grease, insert the cables into the terminals, and tighten the set screws in accordance with torque values shown in the torque value table for cable terminals in the addendum of this manual. See Appendix A, Table A.3.

For aluminum cables, wire brush the wire strands thoroughly. Immediately after wire brushing, coat the cable strands with a quality oxide inhibiting compound such as Penetrox A. Insert exposed wires into the terminals and tighten the set screws in accordance with values shown in the torque Table A-3 in Appendix A of this Instruction Book.

Caution: The torque values shown in the table are for dry threads only. Do not grease or otherwise lubricate the threads on the cable terminals as this will permit over-tightening of the screw and possible damage to the terminal or cable.

Prudence: Les tensions de serrage indiquées dans le tableau sont valables uniquement pour des filetages secs. Ne graissez pas et ne lubrifiez pas les fils des extrémités de câbles. Cela risquerait d'entraîner un serrage excessif de la vis et d'endommager l'extrémité ou le câble.

Fig. 4.23
Control wire entry space
(indoor enclosure)

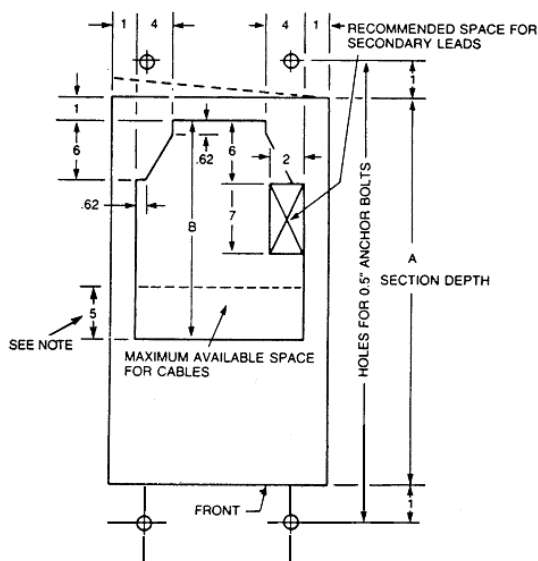

Table 4.23 - Floor plan

Equipment Depth "A" (inches)	Direction of Leads	"B"
54"	Below	19
	Above	24
60"	Below	25
	Above	30
67"	Below	32
	Above	37
74"	Below	39
	Above	44

—
Fig. 4.24
Typical cable lashing

—
Fig. 4.25
Breaker lifting device
assembly (indoor
equipment)

—
Fig. 4.26
Carton containing
breaker lifting device

This should result in the oozing of compound material from between individual strands. Wipe off any excess compound.

Bolt the cable terminal connectors to the ends of the bars in the cable compartment. A non-oxidizing grease should be used at these connection surfaces. The bolts should be tightened in accordance with values shown in the torque Table A.3 in Appendix A of this instruction book.

Lash the cables securely to the cable support, if present, to take their weight off the runbacks and to brace them against short circuit forces in the event of a fault.

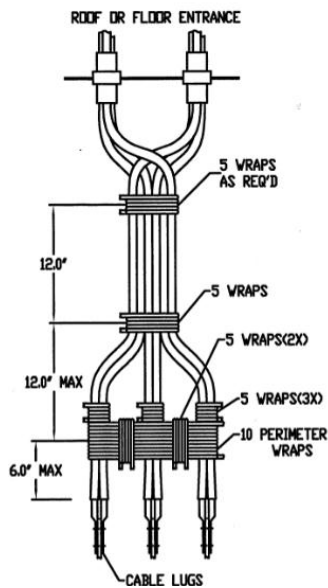

—
Fig. 4.24

Cable supports can be optionally ordered from the factory. The following instructions for cable lashing should be used as a guide and Fig. 4.24 details a typical cable lashing diagram. Run and bend the main cable in a most convenient orientation, making sure the main cable has been located directly up against any cable braces (if present) before it connects to the main cable terminals. Using a 3/8 inch diameter continuous nylon rope or equivalent (minimum 2000 pounds tensile strength) at 6 inches from the main cable terminals, make five revolutions around the "A" and "B" phase main cables, making sure the rope does not overlap.

Make five revolutions around the "B" and "C" phase main cables. With the remaining rope, wrap around the main cable lashing between the "B" and "C" phase and the cable brace (if present) with a minimum of 5 revolutions getting as much revolutions as possible between the phases. Continue wrapping between the "A" and "B" phase around the main cable lashing and the cable brace (if present) with a minimum of 5 revolutions getting as much revolutions as possible between the phases. Securely tie off the remaining rope. Repeat this lashing at every 6-inch interval.

Relays and control devices

Remove all blocking on relays and devices as shown in the instructions accompanying the devices.

Breaker lifting device

Indoor equipment

Fig. 4.25 shows the breaker lifting device assembled on indoor switchgear equipment. When supplied with indoor equipment, the breaker lifting device is shipped in a separate carton completely assembled, Fig. 4.26.

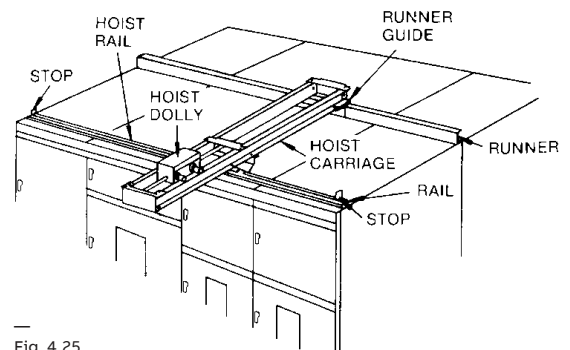

—
Fig. 4.25

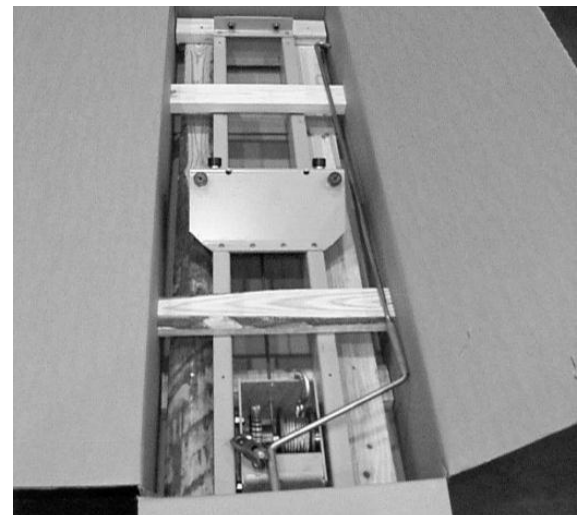

—
Fig. 4.26

—
Fig. 4.27
Removal of breaker lifting device runner guide

—
Fig. 4.28
Location of breaker lifting device rear rollers

—
Fig. 4.29
Front rollers positioned on front track

—
Fig. 4.30
Replacing the runner guide after completion of breaker lifting device installation

—
Fig. 4.31
Removing the bracket locking the dolly

—
Fig. 4.32
Switchgear shipping split front splice plate

Before attempting to install the breaker lifting device assembly on the switchgear equipment, it is necessary to remove the runner guide from the breaker lifting device carriage as shown in Fig. 4.27. Do not dispose of this guide since it must be reinstalled after mounting the breaker lifting device on the equipment.



Note: Maximum recommended lifting capacity is 700 lbs.

Remarque: La capacité de levage maximale recommandée est de 700 livres (317 kg).



—
Fig. 4.29

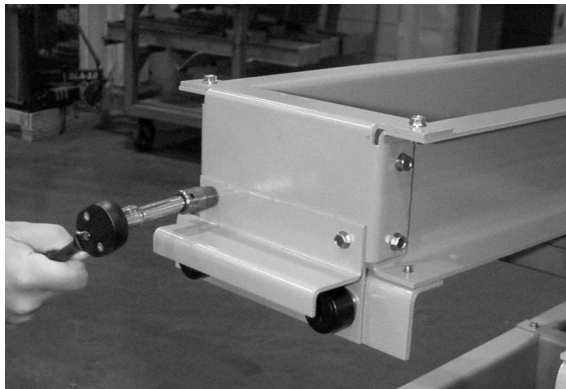

—
Fig. 4.27



—
Fig. 4.30

The breaker lifting device should be lifted into position on top of the switchgear so that the end with two rollers is toward the rear of the equipment, Fig. 4.28.



—
Fig. 4.28



—
Fig. 4.31

If the equipment has been shipped in sections, Fig. 4.32, there are splice plates for the runner guide and breaker lifting device rail attached to each respective part.

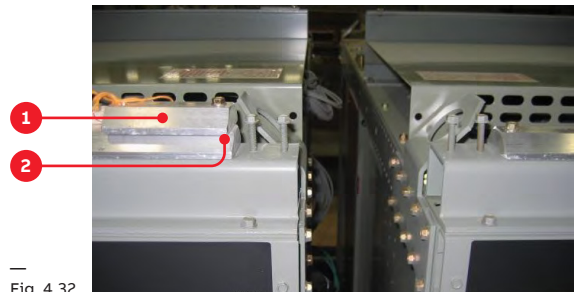

—
Fig. 4.32

The rear wheels can then be hooked under the channel and the front wheels can be positioned on the front track. See Fig. 4.29. The runner guide at the rear should then be reassembled, Fig. 4.30. Stop blocks are provided at each end of the front track to prevent the breaker lifting device from rolling off the ends of the track.

- 1. Breaker lifting device rail splice plate
- 2. Splice plate mounting hardware

—
Fig. 4.33
Switchgear shipping
split rear splice plate

—
Fig. 4.34
Switchgear shipping
breaker lifting device
rail splice plate

—
Fig. 4.35
Retaining clips used
for shipment

After the sections have been aligned and bolted together, on each shipping split section remove the bolt holding the splice plate to the breaker lifting device runner. Retain the splice plate and remove the remaining bolts, Fig. 4.32, and reinstall bolts with splice plates in place. Fig. 4.34 shows a typical breaker lifting device rail splice installed.

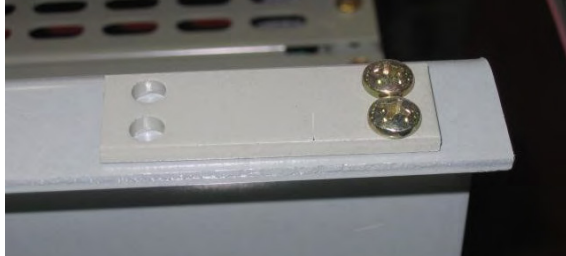

—
Fig. 4.33

On the runner, there is also a splice plate held in place with two screws, Fig. 4.33 shows a typical example. After the breaker lifting device rail splices have been installed, remove and retain the two screws holding the runner splice.

Remove the two screws that are on the other side of the shipping split. Place the runner splice over both sections of the shipping split and align the four mounting holes. Install the four screws that were previously removed.



—
Fig. 4.34

After the splice plates have been installed, run the breaker lifting device over the assembled shipping split to check the alignment of the rail and runner. If necessary, adjust the rail and/or runner for smooth operation of the rollers on the breaker lifting device. On seismic rated equipment, it is necessary to remove the bracket locking the dolly on the breaker lifting device before the device can be used, Fig. 4.31. Replace the bracket after breaker installation or removal is complete.

Outdoor equipment

When the breaker lifting device is provided with outdoor equipment, it is shipped mounted and secured in place. The shipping supports at either end of the breaker lifting device movable track must be removed. To free the dolly, remove the retaining clip used to keep it in place during shipment, as shown in Fig. 4.35.

Final Inspection

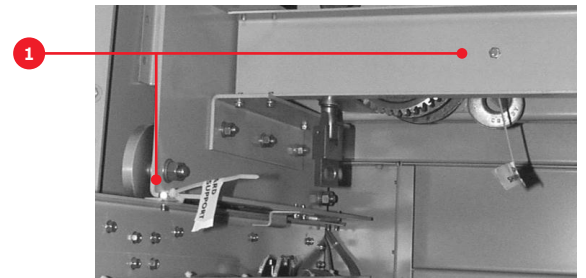

—
Fig. 4.35

1. Retaining clips

Make a final inspection to see that no tools, construction materials, or other foreign matter have been left in the switchgear equipment.

—
Fig. 4.36
Entellisis wall
mounted HMI unit

—
Fig. 4.37
Entellisis wall mounted
HMI unit and devices

—
Fig. 4.38
Enclosure mounting
using bolts and nuts

—
Fig. 4.39
Enclosure mounting with
self-threading bolts

4.3 Anchoring wall mounted HMI (Entellisis only)

General requirements

The Entellisis switchgear can be optionally provided with a wall mounted HMI (Human Machine Interface) unit, Fig. 4.36. Before installation of the HMI unit, ensure that the surface to which the enclosure will be mounted is capable of supporting 85 pounds.

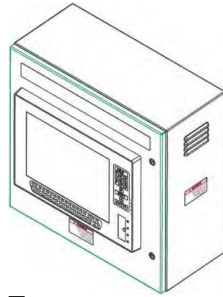

—
Fig. 4.36

Installation

The recommended procedure for installation of the Entellisis wall mounted HMI unit is as follows:

1. Add two conduit connection holes in either the top or bottom surface of the HMI unit enclosure. Do not position the holes less than 1-1/2 inches from the edges of the enclosure, Fig. 4.37.
2. Four mounting holes are provided in the back of the enclosure. Drill an identically spaced pattern of holes in the surface to which the enclosure will be mounted to according to the drawing supplied with the enclosure.
3. Attach the enclosure to the wall or other structure using 3/8 inch bolts, flat washers, and, if the bolts are not self-threading, lock washers and nuts. To ensure proper sealing and enclosure protection rating, use the provided sealing washers. Installing the sealing washers inside the enclosure with the tapered cone against the enclosure and then add the flat washers as shown in Fig. 4.38 and 4.39.
4. Attach suitable conduit fittings to the holes from step 1. Run the conduit to the enclosure as necessary.

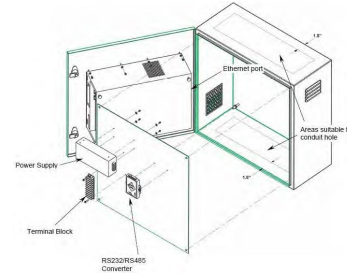

—
Fig. 4.37

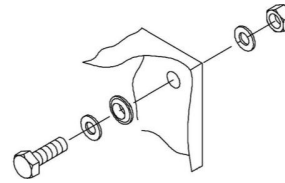

—
Fig. 4.38

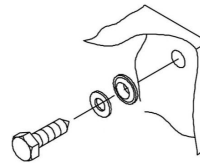

—
Fig. 4.39

Wiring

The recommended procedure for connecting the Entellisis HMI power and communication cables is as follows:

1. Connect the 120V ac line, neutral, and ground wires to the terminal block as shown in the wiring diagram included with the assembly.
2. Connect the incoming Ethernet cable to the port on the side of the HMI display. Secure the wires to the HMI and the enclosure with cable ties.
3. If the enclosure is equipped with a power supply and RS232/RS485 converter, connect the incoming RS485 to the converter terminals labeled RX+ and RX-.

5. Installing and removing circuit breakers

—
Fig. 5.1
Rejection block mounting
used in cassette

—
Fig. 5.2
Rejection pin mounting
used on entelliguard
circuit breaker

5.1 General

Inspection and preparation of circuit breakers

Before installing, operating, or removing a circuit breaker, refer to the breaker instruction manual for preparation, inspection, and test. Check thoroughly for damaged or loose parts and for any dirt or foreign matter which may be in the breaker. Be sure that a thin film of lubricating grease is present on primary disconnects of the switchgear before installing the breaker.

Circuit breaker installation

To install a circuit breaker, proceed as follows:

1. Before installing check the contact areas on each primary disconnect bar or cluster of fingers for foreign matter that may have accumulated. Clean these areas if necessary. Be sure that a thin film of lubricating grease covers the contact areas before putting a breaker in the compartment.
2. Check to see that the breakers match their respective compartments. Each breaker is assigned a part or mark number. This number is shown on the breaker sheets of the summary, the front view drawings, and on the identification card on the breaker shipping carton. The breaker may also be identified using the 20 digit catalog number (AKD-20 Only) or using the 10 digit catalog number (Entellisys Only).
3. To locate the breaker in the proper compartment, refer to the breaker location list on the front view drawing. Find the proper breaker by the identification card on the breaker carton. All identical breakers will have the same mark and catalog number.

Rejection feature

Draw-out breakers of the same type and ratings are interchangeable in their equipment compartments. Draw-out breakers of different type or short-circuit rating are intentionally made noninterchangeable to prevent inserting the wrong type breaker into a draw-out compartment; Unique "rejection hardware" is affixed to each breaker and its cassette. When the wrong type breaker is inserted into a compartment, the pins on the breaker and the blocks in the cassette interfere, thus preventing the wrong breaker from being racked onto the primary stabs.



—
Fig. 5.1



—
Fig. 5.2



Exception: Breakers with a higher short-circuit rating will fit into a compartment keyed for a lower short-circuit rating.

Exception: Les disjoncteurs présentant un pouvoir de coupure élevé peuvent être installés dans un compartiment indiqué pour un pouvoir de coupure inférieur.



Note: If a breaker is rejected by the rejection pins, check the breaker type and rating against the job drawing.

Remarque: Si un disjoncteur est rejeté par les broches de rejet, vérifiez le type de disjoncteur et le pouvoir par rapport au dessin.

The complete rejection pin pattern code is included in Appendix.

5.2 Installing the circuit breakers

Prior to installation

Prior to lifting a breaker to its intended compartment location, observe the following precautions:



Precautions:

1. Check the compartment to ensure that it is free of foreign objects.
2. Verify that the breaker is the correct type for that compartment.
3. Ensure that the breaker is OPEN.
4. Apply a thin fresh coat of lubricating grease to the breaker's primary disconnects.
5. Ensure that the position indicator on the cassette is in the DISCONNECTED position and is correctly positioned for initial engagement. To do this, open the racking handle door and insert the racking handle and rotate it fully counter-clockwise.

Précautions:

1. Vérifiez le compartiment pour vous assurer qu'il ne comporte aucun corps étranger.
2. Assurez-vous que le disjoncteur est du type approprié pour le compartiment.
3. Vérifiez que le disjoncteur est OPEN (ouvert).
4. Appliquez une fine couche de graisse sur les sectionneurs principaux du disjoncteur.
5. Assurez-vous que l'indicateur de position sur la cassette est en position DISCONNECTED (déconnectée) et correctement positionné pour l'installation. Pour cela, ouvrez la porte de la poignée de montage, insérez la poignée, puis faites-la tourner entièrement dans le sens inverse des aiguilles d'une montre.

Installation procedures

To install the EntelliGuard circuit breaker, proceed as follows:

1. Carefully place the breaker in front of the section in which it is to be installed.
2. Open the breaker compartment door by rotating the door latch assembly $\frac{1}{4}$ turn clockwise.
3. Attach the appropriate lifting beam, Table 5.1, to the circuit breaker and breaker lifting device as shown in Fig. 5.3. The carabineers of the lifting beam should be securely closed on the circuit breaker lifting tabs.



Caution: When using the switchgear breaker lifting device, do not unwind the cable completely from the drum. To lift the breaker, turn the device operating crank clockwise. To lower the breaker, turn the device operating crank counter-clockwise.

Prudence: Lorsque vous utilisez le dispositif de levage du disjoncteur de l'appareillage électrique, ne déroulez pas entièrement le câble. Pour lever le disjoncteur, tournez la manivelle du dispositif dans le sens des aiguilles d'une montre. Pour abaisser le disjoncteur, tournez la manivelle du dispositif dans le sens inverse des aiguilles d'une montre.

—
Fig. 5.3
Attaching lifting
beam to entelliguard
circuit breaker

—
Fig. 5.4
Alignment of
entelliguard circuit
breaker with cassette

—
Fig. 5.5
Entelliguard circuit
breaker positioned on
cassette draw-out rails

Note: Envelope 1 and 2 circuit breakers share a common lifting beam. The lifting beam has two unique positions for the carabiners to properly lift each of these circuit breakers as detailed in Fig. 5.3.

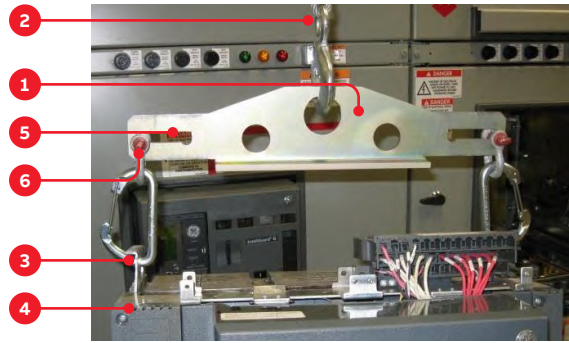

—
Fig. 5.3

1. Lifting Beam
2. Breaker Lifting Device Hook
3. Carabineers
4. Circuit Breaker Lifting Tabs
5. Envelope 1 Carabineer Position
6. Envelope 2 Carabineer Position (shown)

Table 5.3 - EntelliGuard lifting beams

Catalog number	Poles	Description
GLD3F12	3	Envelope 1 or 2 lifting beam
GLD3F3		Envelope 3 lifting beam
GLD4F12	4	Envelope 1 or 2 lifting beam
GLD4F3		Envelope 3 lifting beam

4. Using the switchgear breaker lifting device or a suitable lifting mechanism and the appropriate lifting beam, raise the breaker above the elevation of the breaker compartment rails.



Warning: Do not stand under the circuit breaker during the lifting or lowering operation.

Avertissement: Ne restez pas sous le disjoncteur pendant l'opération de levage ou de descente.

5. Fully withdraw the rails to their stops.

6. Slowly lower and guide the circuit breaker to align with the breaker compartment. Prior to lowering the circuit breaker onto the rails, be sure the breaker metallic side frames, Figs. 5.4 and 5.6 are aligned with the grooves in the cassette.

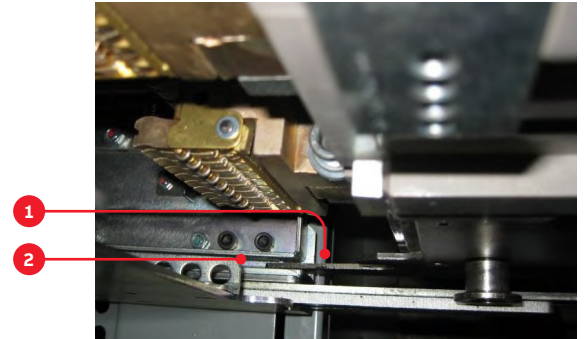

—
Fig. 5.4

1. Circuit Breaker Side Frame
2. Cassette Groove

7. With both sides of the circuit breaker aligned with the grooves in the cassette, slowly lower and guide the breaker to allow the 4 breaker wheels to align with the rails. See Fig. 5.5. Remove the lifting beam. The breaker is now positioned on the draw-out rails.

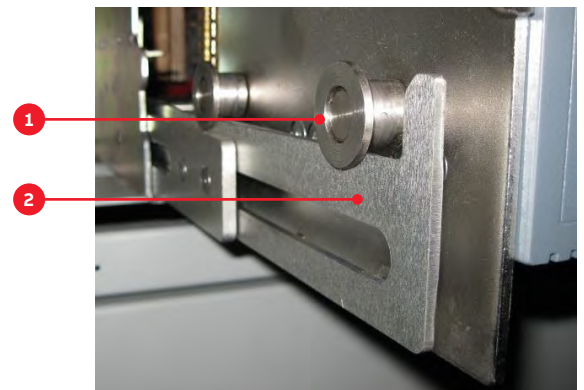

—
Fig. 5.5

1. Circuit Breaker Wheels
2. Cassette Draw-out Rails

—
Fig. 5.6
Using breaker lifting device and lifting beam to raise or lower circuit breaker

—
Fig. 5.7
Engage the racking shaft with the racking handle

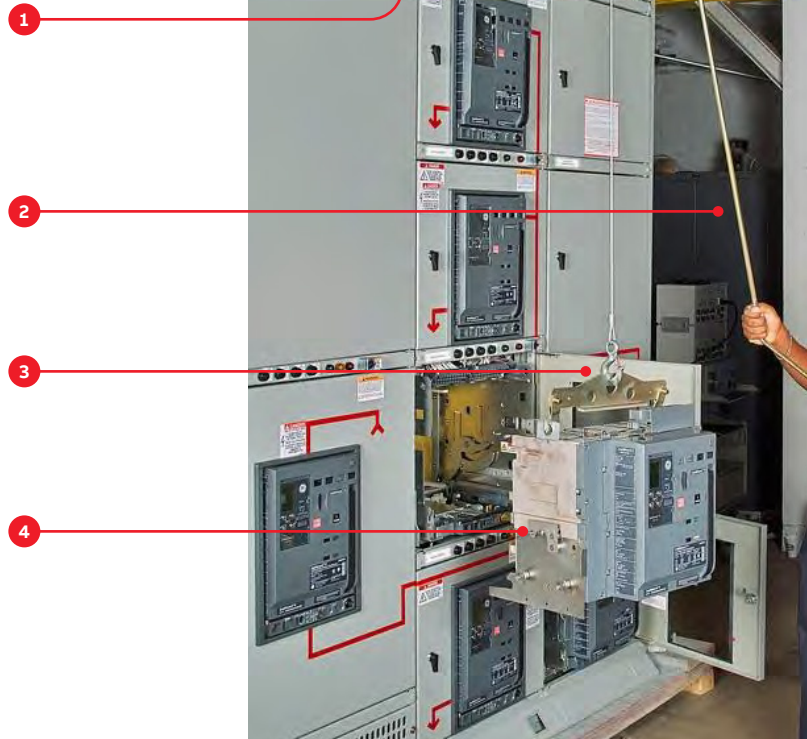

—
Fig. 5.6

1. Switchgear Breaker Lifting Device
2. Operating Crank
3. Lifting Beam
4. Circuit Breaker Side Frame

8. Roll the breaker into the compartment until the racking forks meet the racking pin, this is the DISCONNECT position. If an incorrect breaker has been installed, the interference pins on the breaker will interfere with the rejection pins in the compartment prior to reaching the disconnect position. At this point, the racking forks on the cassette are contacting the fixed racking pins on the breaker.

9. Slide rails back into compartment. Close the compartment door and rotate latch ¼ turn counter-clockwise.

10. Engage the racking handle by using a slot screwdriver to open the racking shaft door by rotating it clockwise, then insert hex manual racking handle.

11. Rotate the handle clockwise as far as it will go. As you rotate the handle clockwise, the breaker will travel from the DISCONNECT, through the TEST position (you will notice an audible click), and then into the CONNECT position. The breaker position can be seen on the indicator barrel, located on the cassette escutcheon.



—
Fig. 5.7

1. Breaker Draw-out Position Indicator
2. Racking Shaft Access
3. Racking Handle

5.3 Removing the circuit breakers



Warning: Do not stand under the circuit breaker during the lowering operation.

Advetissement: Ne restez pas sous le disjoncteur pendant l'opération de descente.



Caution: When using the switchgear breaker lifting device, do not unwind the cable completely from the drum. To lift the breaker, turn the device operating crank clockwise. To lower the breaker, turn the device operating crank counter-clockwise.

Prudence: Lorsque vous utilisez le dispositif de levage du disjoncteur de l'appareillage électrique, ne déroulez pas entièrement le câble. Pour lever le disjoncteur, tournez la manivelle du dispositif dans le sens des aiguilles d'une montre. Pour abaisser le disjoncteur, tournez la manivelle du dispositif dans le sens inverse des aiguilles d'une montre.

To remove the EntelliGuard circuit breaker, proceed as follows:

1. Open the breaker by pressing the OFF/OPEN button.
2. Use a slot screwdriver to open the racking shaft door by turning clockwise. Insert the racking handle and rotate it counterclockwise until the breaker travels from CONNECT through TEST to the DISCONNECT position, as shown by the position indicator. This operation should be performed with the door closed. If the breaker closing spring is fully charged, it will be automatically discharged when the breaker is moved to the WITHDRAWN position.
3. Open the compartment door and fully extend the draw-out rails. Roll breaker out to rail stops. This is the WITHDRAWN position.
4. Before proceeding, visually check the breaker's spring charge and close indicators to verify that breaker is open and the springs are discharged.
5. Attach the lifting device and raise breaker off draw-out rails.
6. Push the draw-out rails back into the compartment.
7. Pull the breaker forward until the primary disconnects clear the compartment.
8. Lower the breaker onto a flat surface free of protrusions that could damage the breaker's internal parts.
9. Close the breaker compartment door. If the circuit breaker will be removed from the compartment for an extended period of time. An optional dead front cover, catalog #GFUTDF, may be ordered and installed to prevent access to live conductor parts.

6. Testing and inspecting

6.1 General

After the equipment has been installed and all connections made, it must be tested and inspected before it is put in service. Although the equipment and devices have been tested at the factory, a final field test must be made to be sure that the equipment has been properly installed and that all connections are correct.



Warning: The equipment must be completely de-energized while the tests are in progress.

Avertissement: Pour les tests, l'équipement doit être entièrement coupé de la source d'alimentation principale.

Directions for testing relays, instruments, and meters are given in the instruction book furnished for each device. The proper settings of the protective relays and circuit breaker trip units or EntelliGuard Messengers are normally determined from a complete power system coordination study performed by the purchaser or their consultant; therefore, the settings of these devices must be made by the purchaser. When the equipment is shipped from the factory, the time dial of all inverse-time induction disc relays (i.e., IFC types) is set to zero to prevent contact bounce during transportation.



Note: The trip setting adjustments of the trip unit or Messenger for each circuit breaker may be at any setting when shipped from the factory and must be correctly set prior to energization of the equipment.

Remarque: Le paramètre de l'unité de déclenchement de chaque disjoncteur peut être défini sur n'importe quelle valeur après la livraison. Il doit être correctement défini avant toute alimentation de l'équipement.

General instructions for setting the relays are given in the applicable Relay or Trip Unit Instruction Book. Directions for Entellisys instrumentation is provided in DEH-501. The extent of the tests on the equipment as a whole will depend on the type and function of the equipment. Tests which should be performed, however, include circuit breaker operation, and switchgear meggering, phasing, and grounding checks.

High-potential tests to check the integrity of the insulation are not necessary if the installation instructions are carefully followed. If local codes demand this test, or the purchaser wishes to make highpotential tests, the voltage should not exceed 75 percent of the IEEE factory test voltage. For the power circuit, the IEEE factory test voltage is two times switchgear rating plus 1,000 volts. See Table 6.1. Potential and control power transformers must be disconnected during highvoltage testing.

Table 6.1 - Factory high potential test values

Switchgear voltage rating	ANSI test voltage, ac RMS	Field test voltage, ac RMS
600V	2200V	1650V
480V	1960V	1470V
240V	1480V	1110V

6.2 Key interlocks

After initial installation of the switchgear equipment, all necessary interlock keys should be inserted into the appropriate locks and all spare keys should be stored in a location in accordance with the owner's established procedures.



Caution: Refer to the key interlock schematic included in the summary furnished with the equipment to determine the sequence of operation and the correct number of operating keys required. This precaution is necessary since the improper use of spare keys will defeat the interlocking scheme.

Prudence: Reportez-vous au schéma des dispositifs de verrouillage à clé inclus dans le récapitulatif fourni avec l'équipement pour déterminer l'ordre des opérations et le nombre de clés de fonctionnement requises. Cette précaution est nécessaire car toute utilisation incorrecte de clés de rechange bloquera le dispositif de verrouillage.

6.3 Breaker operation test

All compartments housing EntelliGuard circuit breakers have a TEST position in which the breaker primary contacts are disconnected while the secondary contacts are still engaged. This TEST position permits complete testing of the electrical control circuit without energizing the primary power circuit. When the breaker is first put into service, its control circuit must be thoroughly tested while in this position to make sure that all closing and tripping circuits are complete and functioning properly. The TEST position is not suitable for inspection and maintenance of the breaker and should therefore be used only for testing breaker operation. Refer to the appropriate breaker instruction manual for other preoperational checks on the breakers. See DEH-41304 (AKD-20 Only) or DEH-41526 (Entellisys Only).

6.4 EntelliGuard trip units (AKD-20 only)

The calibration of the EntelliGuard trip unit should be checked with the Type GTUTK20 test kit, a portable instrument designed for the field testing of EntelliGuard trip units. The complete trip system is comprised of the following components:

1. Solid-state Trip Unit with rating plug
2. Phase Current Sensors
3. Flux Shift Magnetic Trip Device
4. When applicable, a Neutral Sensor for units containing a Ground Fault Trip element.

All components, except the Neutral Sensor, are integrally mounted in the circuit breaker. When used, the Neutral Sensor is separately mounted in the bus or cable compartment of the switchgear. In draw-out construction, it is automatically connected to the trip unit in the breaker via a draw-out secondary disconnect block.



Caution: Never disengage the trip unit on a breaker that is energized and carrying load current. This will open-circuit the current sensors, allowing dangerous and damaging voltages to develop.

Prudence: Ne dégagez jamais l'unité de déclenchement d'un disjoncteur alimenté et transportant du courant de charge. Cela ouvrirait le circuit des capteurs électriques et des tensions dangereuses pourraient se développer.

Complete Instructions for testing the trip units are included with the test set. The trip unit user manuals are DEH-4567 (EntelliGuard trip unit) and DEH-4568 (GTUTK20).

6.5 Entellisys system test kit (Entellisys only)

The Entellisys system can be tested with the Type ETSTESTKIT03 test kit, a portable instrument designed for field-testing of the Entellisys system functionality. The test kit user manual is DEH-503.

6.6 Final steps to be taken before energizing equipment

The following steps should be taken before energizing the equipment:

1. Manually exercise all switches, circuit breakers, and other operating mechanisms to make certain they are properly aligned and operate freely.
2. Conduct an electrical insulation resistance test to make sure the switchgear is free from short circuits and grounds. This should be done both phase-to-ground and phase-to-phase with the switches or circuit breakers both opened and closed. This test should be performed with a 1000 volt meggar. Disconnect all control circuits before checking resistance.
3. Check any electrical relays, meters, or instrumentation to determine that connections are made properly and the devices function properly.
4. Electrically exercise all electrically operated circuit breakers, and other mechanisms (but not under load), to determine that the devices operate properly. An auxiliary source of control power may be necessary to provide power to the electrical operators.
 - a. (Entellisys Only):
Using the Entellisys HMI, exercise all EntelliGuard circuit breakers to determine all devices are functioning correctly. For Entellisys HMI instructions, reference DEH-501.
5. Test the ground fault protection system (if furnished) in accordance with the manufacturer's instructions.
 - a. (Entellisys Only): Test all protective functions using the Entellisys Test Kit (ETSTESTKIT03). Reference DEH-503 for instructions.
6. Set the adjustable current and voltage trip mechanisms to the proper values. Experience has indicated that damage from faults can be reduced if the devices used for overload and short circuit protection are set to operate instantaneously (that is, without intentional time delay) at 115 percent of the highest value of phase current which is likely to occur as the result of any anticipated motor starting or welding currents.
7. Make certain that field wiring is clear of live bus and, where necessary, physically secured to withstand the effects of fault currents.
8. Check to determine that all grounding connections are made properly.
9. Remove all debris, scrap wire, etc., from the switchgear interior before closing the enclosure.
10. Install covers, close doors, and make certain that no wires are pinched and that all enclosure parts are properly aligned and tightened.

7. Operating the switchgear

7.1 Circuit breaker operation

General

Included below are abbreviated operating instructions for EntelliGuard circuit breakers. Before activation of the circuit breakers or operation of the switchgear equipment, thoroughly read, and be familiar with the circuit breaker manuals which will be supplied as supplementary information to this manual. Publication number is DEH-41304 (AKD-20 Only) or DEH-41526 (Entellisys Only).

Manually operated circuit breakers

Closing operation

Manually operated EntelliGuard circuit breakers are equipped with a integral charging handle and a push button marked CLOSE on the front of the escutcheon. The spring must be charged first.

- A complete charge is accomplished by pulling the handle down about 90° (until it stops) ten times to fully charge the closing springs. This will not close the breaker contacts. The charge indicator will show CHARGED on a yellow background.

Opening Operation

A mechanically operated OPEN button mounted on the breaker escutcheon, operates the trip shaft to open the breaker.

Opening operation (Entellisys only)

The Entellisys HMI may also be used to electrically open the breaker.

Electrically operated circuit breakers closing operation

Electrically operated breakers may be closed by ac control power, or dc (normally station or standby battery) control power. Refer to the provided elementary diagrams for information on control circuitry.

Closing operation (Entellisys only)

The Entellisys HMI may be used to electrically close the breaker.

Opening operation

A shunt trip device is used for electrical tripping and each breaker can have up to two shunt trip accessories installed.

Opening operation (Entellisys only)

The Entellisys HMI may also be used to electrically open the breaker.

—
Fig. 7.1
Breaker shown in
CONNECT position

—
Fig. 7.2
Breaker shown in
TEST position

—
Fig. 7.3
Breaker shown in
DISCONNECTED position

7.2 Circuit breaker draw-out operation

Breaker positions

Refer to Figs. 7.1, 7.2, and 7.3. The draw-out operation features four positions:

1. Connected - In the CONNECTED position, the primary and secondary disconnects are fully engaged. The breaker must be tripped before it can be racked out of this position.
2. Test - When in the TEST position, the primary contacts are disconnected, but the secondary contacts remain engaged. This allows complete breaker operation without energizing the primary circuit.
3. Disconnected - In the DISCONNECTED position, neither primary nor secondary contacts are made. Breakers may be racked between these three positions with the compartment door closed and latched.
4. Withdrawn - With the door open, the breaker can be rolled out manually from the DISCONNECTED to the WITHDRAWN position. Here, the breaker is completely out of its compartment, ready for removal.

Draw-out operation

All breakers are supported on the draw-out rails mounted on the side walls of the cassette. On EntelliGuard breakers, two wheels on each side of the breaker rest on each draw-out rail.

Motion is provided by a mechanism mounted on the bottom of the cassette. This mechanism drives racking cams which engage pins anchored to each side of the breaker. The cams are driven by a removable racking handle or remote racking device, catalog #EGGRRLV, which engages the mechanism. The handle is inserted through an opening in the cassette escutcheon below the breaker.

Turning the handle in a clockwise direction drives the breaker into the compartment. As the breaker disconnect fingers engage the stab tips, a high force will be felt. Turn the racking handle until the indicator barrel clearly shows CONNECTED. The position of the breaker is given by the position indicator in the cassette escutcheon as it moves through the door cutout.



—
Fig. 7.1



—
Fig. 7.2



—
Fig. 7.3

—
Fig. 7.4
Switchgear front
access doors

—
Fig. 7.5
Front access door details

7.3 Front doors

Operation

The front access doors on all standard switchgear are hinged and equipped with a ¼-turn latch, Fig. 7.4. To open the door, rotate the knob clockwise ¼ turn.

Removal and installation

Refer to Fig. 7.5 and remove/install switchgear front doors.

Door removal

To remove the switchgear door, proceed as follows:

1. Open door.
2. Loosen the two screws holding the top hinge pin plate and allow the pin to drop out of the hinge block. See Fig. 7.5.
3. Move the top of the door away from the switchgear, avoiding the door stop and lift the door out of the lower hinge pin socket. Retain the washers.

Door installation

To install the switchgear door, proceed as follows:

1. Insert washer, then place lower hinge pin into hinge pin socket on switchgear. See Fig. 7.5.
2. Swing door open, position behind door stop and align hinge pin socket.
3. Insert the hinge pin into the hinge block and tighten two screws.
4. Close door.



—
Fig. 7.4

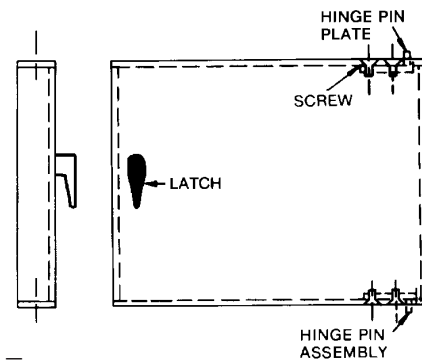

—
Fig. 7.5

—
Fig. 7.6.
Future circuit breaker
compartment

—
Fig. 7.7.
Key interlocks shown
in cassette

—
Fig. 7.8.
Cassette racking door
padlock device

7.4 Switchgear accessories

Future circuit breaker compartments

Breaker compartments designed for future use are complete and ready to use. These breaker compartments have a steel panel to cover the door cutout, Fig. 7.6. To prepare the circuit breaker compartment for use, remove the steel outer cover.



Warning: Terminals behind the steel barrier may be electrically hot.

Avertissement: Les bornes situées derrière la barre d'acier peuvent être sous haute tension.

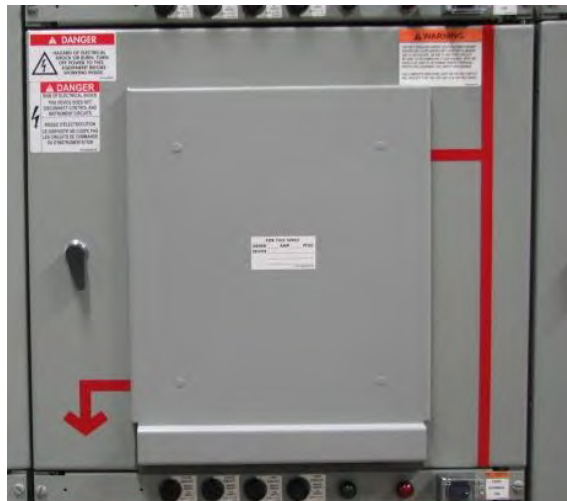

—
Fig. 7.6.

Circuit breaker key interlock

General

A circuit breaker key interlock is available to provide protection against unauthorized operation. See Fig. 7.7. The key interlock is mounted on the right of escutcheon of the cassette below the breaker.

The typical interlock system is designed so that the key may be removed from the lock only when the breaker is tripped. The key actuates a cam that elevates the trip bar on the cassette and the breaker is rendered trip free.

Key interlock operation check

The operation of the key interlock should be checked as follows:

1. With the breaker in the CONNECT position, manually trip the breaker. This then allows the key interlock to elevate the trip bar. When the trip bar is elevated, the breaker cannot be closed but the key can be removed. The breaker will remain trip free until the key is returned and the trip bar is lowered.
2. If desired, the breaker may be moved to either the TEST or DISCONNECT position while the key is removed from the lock. In these positions, the breaker cannot be operated for checking or maintenance.



—
Fig. 7.7.

Padlocking the cassette racking door

The cassette racking door can be padlocked to prevent access to the racking door. The cassette can be padlocked with the breaker in any position or without the breaker installed. Up to three padlocks can be placed on a cassette. A padlock with a hasp thickness of at least 0.120" should be used to padlock the racking shaft door. To padlock cassette racking door, pull out the racking door locking tab and insert padlock, see Fig 7.8.



—
Fig. 7.8.

—
Fig. 7.9.
Compartment
padlock device

—
Fig. 7.10.
Shutter padlocking

Padlocking the cassette

The circuit breaker compartment door must be opened to put the padlock on; however, there is no interference with the door after the padlock has been placed in position. Padlocks will prevent the acceptance of breakers in the cassette. The padlock device on the cassette will accept up to three padlocks on both the left and right sides of the cassette. See Fig. 7.9.



—
Fig. 7.9.

Padlocking the shutter

The shutter on each cubicle can be padlocked to prevent access to the live primary conductors. The shutter can be padlocked without the breaker installed. One padlock can be placed on a cassette. To padlock shutter, pull out the shutter locking tab and insert padlock, see Fig 7.10. Pulling out the shutter locking tab actuates a rod that goes through moving shutter parts that prevents it from opening.

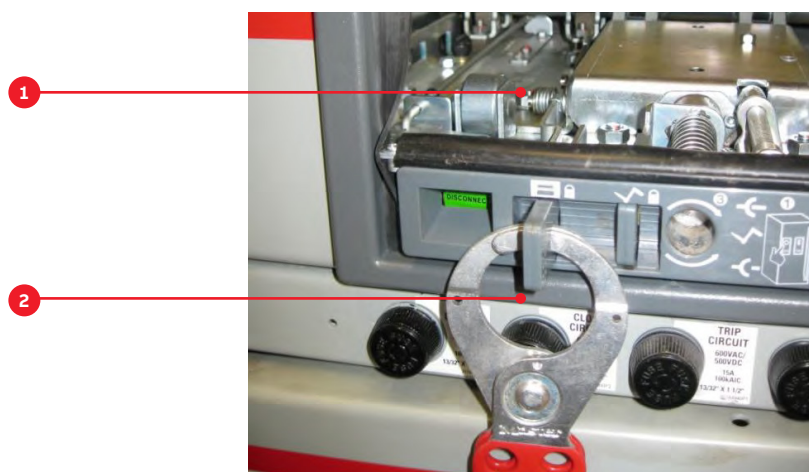

—
Fig. 7.10.

1. Shutter locking rod
2. Shutter padlock tab

Removing the shutter unit

Refer to DEH-41696 for full instructions on the removal of the shutter unit.



Warning: Unless the proper precautions are taken, the removal of a shutter unit presents the hazard of electrical shock and burn. Do not remove the shutter unit unless the equipment has been deenergized. Failure to do this can result in serious injury.

Avertissement: Si les précautions requises ne sont pas prises, le retrait d'un obturateur présente un risque de choc électrique et de brûlure. Ne retirez pas l'obturateur, sauf si l'équipement n'est plus alimenté. Vous courez sinon le risque de vous blesser gravement.

Installing the shutter unit

Refer to GEH-41696 for full instructions on installation of shutter units. Available shutter units are listed below on the table listing available catalog numbers.

Table 7.1 - Factory high potential test values

Catalog Number	Description
GM2F120H2SSL	Envelope 1 Shutter
GM2F220H2SSL	Envelope 2 Shutter (2,000A or below)
GM2F232M2SSL	Envelope 2 Shutter (Above 2,000A)
GM2F350M2SSL	Envelope 3 Shutter



Warning: Unless the proper precautions are taken, the installation of a shutter unit presents the hazard of electrical shock and burn. Do not install the shutter unit unless the equipment has been de-energized. Failure to do this can result in serious injury.

Avertissement: Si les précautions requises ne sont pas prises, l'installation d'un obturateur présente un risque de choc électrique et de brûlure. N'installez pas d'obturateur, sauf si l'équipement n'est plus alimenté. Vous courez sinon le risque de vous blesser gravement.

8. Energizing the switchgear

8.1 Before energizing

Before switchgear is energized, a thorough final check should be made using the following checklist: Refer to section 6.5 for additional information.

- Breakers and other operating mechanisms exercised
- Electrical insulation resistance tested phase-to-phase and phase-to-ground
- Relays, meters and instruments properly connected
- Electrically operated breakers and operating mechanisms exercised
- Ground fault protection system tested
- Adjustable trips properly set
- Field wiring secured and free of live bus
- Grounding connections made
- All debris, scrap wire, etc. removed
- All covers installed, doors closed and latched

There should be no load on the switchgear when it is energized.

Turn off all of the downstream loads, including those such as motor control centers and other devices which are remote from the switchgear. The equipment should be energized in sequence by starting at the source end of the system and working toward the load end. In other words, energize the main devices, then the feeder devices, and then the branch-circuit devices.

Turn the devices on with a firm positive motion (AKD-20 Only). Using the Entellisys HMI, turn on the devices (Entellisys Only).

8.2 Energizing procedures



Caution: Energizing switchgear for the first time is potentially dangerous. Therefore, qualified electrical personnel should be present when the equipment is energized. If problems caused by damage or poor installation practices have not been detected in the checkout procedure described previously, serious damage can result when power is turned on.

Prudence: La première alimentation de l'appareillage électrique présente potentiellement un danger. Par conséquent, un électricien qualifié doit être présent. Si des problèmes dus à des dommages ou à une mauvaise installation n'ont pas été détectés pendant la procédure de vérification décrite précédemment, l'alimentation peut générer d'importants dommages.

9. Maintaining the switchgear

9.1 Maintenance requirements

General

A periodic maintenance schedule must be established to obtain the best service from the switchgear. An annual check of the switchgear devices and all connections should be made as a minimum requirement. Equipment subject to highly repetitive operation may require more frequent maintenance. A permanent record of all maintenance work should be kept. The record should include a list of periodic checks and tests made, the date they were made, the condition of the equipment, and any repairs or adjustments that were performed. Maintenance employees must follow all recognized safety practices, such as those contained in NFPA 70B: Electrical Equipment Maintenance, and NFPA 70E: Standard for Electrical Safety in the Workplace and in company or other safety regulations.



Warning: Solid insulation surrounding an energized conductor and power apparatus must never be relied upon to provide protection to personnel.

Avertissement: La protection du personnel ne doit jamais reposer uniquement sur l'isolation entourant un conducteur alimenté et un appareil électrique.

For specific information regarding the maintenance of devices, such as circuit breakers, relays, meters, etc., refer to the separate instruction book furnished for each device.

9.2 Breaker and instrument compartments

Periodic inspection of the circuit breaker is recommended at least once a year. More frequent inspections are recommended where severe load conditions, dust, moisture or other unfavorable conditions exist, or if the vital nature of the load warrants it. Always inspect the breaker after a short-circuit current has been interrupted.



Breakers

Test for proper operation

Test and inspect all circuit breakers for proper operation as follows:

1. Operate each breaker while in the TEST position and check all functions. This is particularly important for breakers that normally remain in either the opened or closed positions for long periods of time.



Warning: Primary equipment must be completely de-energized while tests on control circuits, etc. are being conducted. Be sure that all areas of feedback from secondary circuits, as well as outside sources, are disconnected.

Avertissement: L'équipement principal doit être entièrement coupé de la source d'alimentation principale lorsque des tests sont réalisés sur les circuits de commande, etc. Assurez-vous que toutes les zones de retour de tension des circuits secondaires, ainsi que les sources extérieures, sont déconnectées.

2. Remove the breakers from their compartments to a clean maintenance area. Close compartment door and cover the breaker cutout to prevent access to live parts.



Warning: De-energize equipment completely before doing maintenance work on any devices, connections, bus work, breaker or feeder cable compartments. This includes de-energizing any connections to outside primary or secondary sources, such as transformers, tie lines, etc.

Avertissement: Coupez l'alimentation principale de l'équipement avant d'effectuer des opérations d'entretien sur les dispositifs, les connexions, le jeu de barres ou les compartiments des disjoncteurs ou des câbles d'alimentation. Cela inclut également la coupure de toutes les connexions vers des sources principales ou secondaires extérieures, telles que des transformateurs, lignes d'interconnexion, etc.

Checks after breaker is de-energized

At the time of inspection, the following checks should be made after the breaker has been de-energized.

1. Manually operate the breaker several times, checking for obstructions or excessive friction. Manual closing of an electrically operated breaker may be performed by the following two steps:
 - a. To charge the mechanism springs, pull the operating handle down until it stops (about 90°) ten times for the EntelliGuard breaker. The charge indicator will show CHARGED on a yellow background.
 - b. Depress the CLOSE button on the front of the breaker. The springs should discharge and, if the latch is properly reset, the breaker will close.
2. Electrically operate the breaker several times to check performance of the electrical accessories.
3. Visually check the breaker for loose hardware on the breaker; also, check the bottom of the compartment for any hardware that has fallen from the breaker.
4. Remove and inspect the arc quenchers and contacts for breakage or excessive burning.
5. The performance of the solid-state current trip devices may be checked with a suitable test set. Check electro-mechanical devices for positive trip in accordance with the instructions in the proper Maintenance Manual.
6. Check insulating parts for evidence of overheating and for cracks that indicate excessive thermal aging.

Refer to circuit breaker instruction manuals for detailed maintenance instructions and information for replacement of parts. See DEH- 41304 (AKD-20 Only) or DEH-41526 (Entellisys Only).

Lubrication

In general, the circuit breaker requires moderate lubrication. Bearing points and sliding surfaces should be lubricated at the regular inspection periods with a thin film of lubricant. Before lubricating, remove any hardened grease and dirt from latch and bearing surfaces with mineral spirits then wipe with a clean rag.



Caution: All excess lubricant should be removed with a clean cloth to avoid accumulation of dirt or dust.

Prudence: Tout excès de lubrifiant doit être retiré avec un chiffon propre pour éviter l'accumulation de poussières ou de saletés.

On draw-out breakers, the contact surface of the disconnect fingers should be cleaned and greased with lubricant.

Instruments, instrument transformers, and relays

Check and inspect all devices to see that they are functioning properly. Check that all electrical connections are tight. Check mounting of the device.

Under normal conditions, the protective relays do not operate; therefore, it is important to check the operation of these devices regularly. Refer to Relay Instruction Books for detailed instructions.

Breaker compartment interiors

Warning: De-energize equipment completely before doing maintenance work in compartments. This includes de-energizing any connections to outside primary or secondary sources, such as transformers, tie lines, etc.

Avertissement: Coupez l'alimentation principale de l'équipement avant d'effectuer des opérations d'entretien dans les compartiments. Cela inclut également la coupure de toutes les connexions vers des sources principales ou secondaires extérieures, telles que des transformateurs, lignes d'interconnexion, etc.

Thoroughly clean the interior of the breaker and instrument compartments. Use a vacuum cleaner and clean rags only. Do not use steel wool or oxide papers. Blowing with compressed air is not recommended.

Check indicating devices, mechanical and key interlocks. Check primary disconnecting device contacts for signs of abnormal wear or overheating. Discoloration of the silvered surfaces is not ordinarily harmful. These contacts should be cleaned only by wiping with a lint-free cloth. Clean the racking mechanism and lubricate with lubricant.

Before replacing the breaker, wipe off the primary disconnecting device contacts. Apply a thin coat of lubricant to the stationary studs and to the primary disconnects on the breaker.

9.3 Bus area

Warning: De-energize equipment completely before doing maintenance work on any devices, connections, bus work, breaker or feeder cable compartments. This includes de-energizing any connections to outside primary or secondary sources, such as transformers, tie lines, etc.

Avertissement: Coupez l'alimentation principale de l'équipement avant d'effectuer des opérations d'entretien sur les dispositifs, les connexions, le jeu de barres ou les compartiments des disjoncteurs ou des câbles d'alimentation. Cela inclut également la coupure de toutes les connexions vers des sources principales ou secondaires extérieures, telles que des transformateurs, lignes d'interconnexion, etc.

Inspect and check the bus area as follows:

1. Inspect the buses and connections carefully for evidence of overheating or weakening of the insulating supports. If bus insulation is present, remove the molded covers over the main bus connection to expose joints for inspection.
2. Check all connection bolts in the bus compartment and all bracing bolts for tightness. See the Torque Table A.1 in Appendix A.
3. Vacuum and, with a clean rag, wipe the buses and supports.
4. Visually inspect the insulation on the bars that run from the breaker studs through the bus structure to the cable area.
5. After cleaning, megger and record the resistance to ground and between phases of all insulated bars and all buses and connections. Disconnect all control circuits before checking resistance. Do not use over a 1500-volt megger. Since definite limits cannot be given for satisfactory insulation resistance values, a record must be kept of the readings.

Weakening of the insulation from one maintenance period to the next can be recognized from the recorded readings. The readings should be taken under similar conditions each time, if possible, and the record should include the ambient temperature and humidity.

9.4 Cable and busway compartment

Inspect and check the cable and busway compartment as follows:

1. Inspect all power cable connections for signs of overheating and tighten all connections. If severe discoloration or if damage is apparent, remove the damaged portion of the cable.



Caution: Be sure the condition which caused the over-heating has been corrected before energizing.

Prudence: Veillez à ce que le problème à l'origine de la surchauffe ait été corrigé avant de relancer l'alimentation.

2. Check all bolts that hold cable terminals to the connection bars for tightness.
3. Check the neutral bus and ground bus connection and mounting bolts for tightness.
4. Check that all secondary control wiring connections are tight and that all control cabling is intact.

9.5 Overall switchgear

Make the following checks on the complete switchgear equipment.

- Clean and inspect all painted surfaces and retouch where necessary.
- Check to see that all anchor bolts and other structural bolts are tight.
- Check that all breaker and instrument compartment door latches operate properly.
- If the switchgear is equipped with heaters, check to see that all heaters are energized and operating.
- For exterior vent openings in equipment furnished with air filters, the foam filter elements should be removed and washed in warm soapy water, rinsed, and reassembled at least annually. Elements should be inspected before re-assembly and replaced if any signs of deterioration are evident.

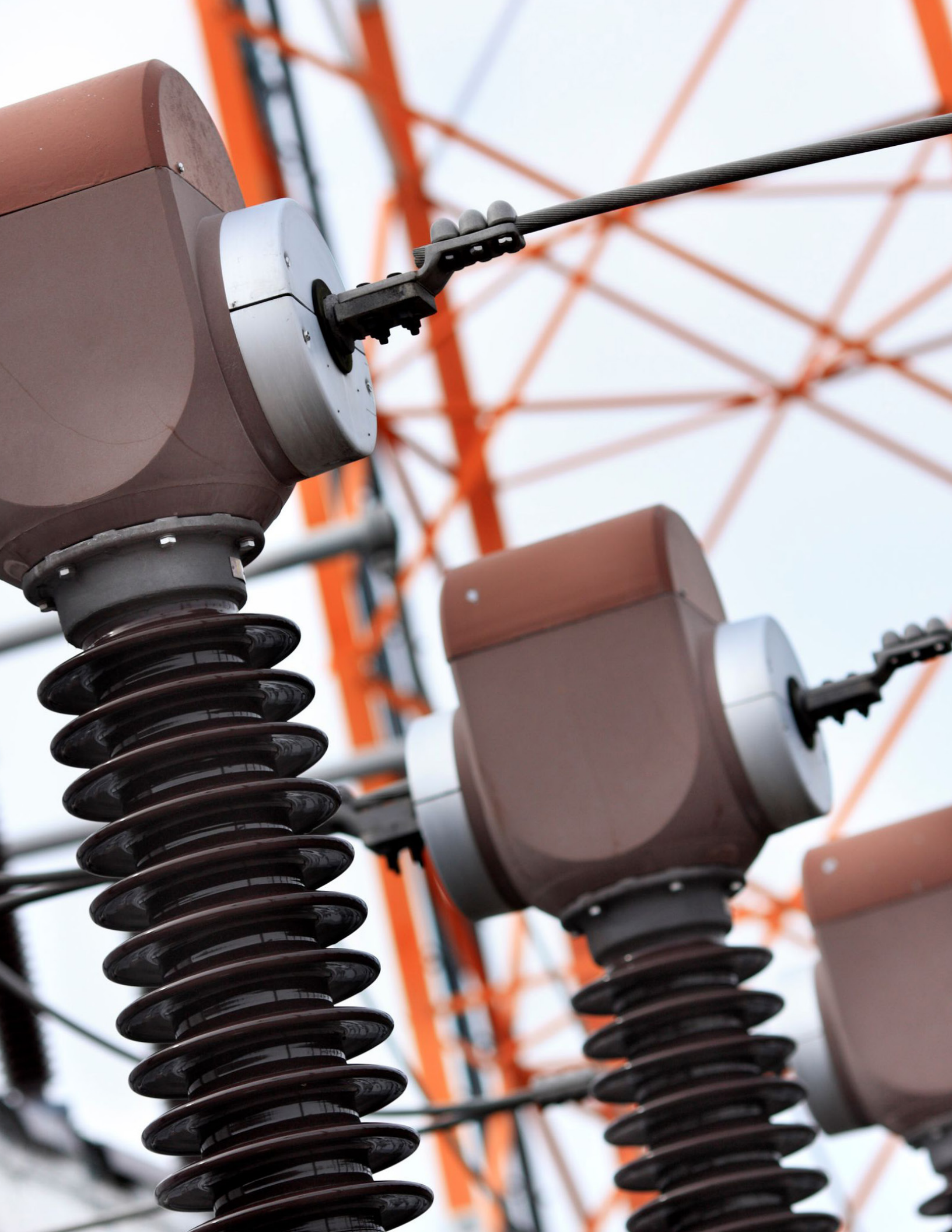

9.6 Paint refinishing

Indoor switchgear is finished with ANSI-61 gray acrylic enamel paint (PPG W42713, part number 21525032650). To refinish damaged areas, remove all loose paint, rust, scale, oil or grease. Sand any scratches smooth using 220 grit paper or finer.

Apply a coat of good acrylic enamel primer (Sherman-Williams E61 A 60, part number 21525025200) with a viscosity of approximately 24-32 seconds using a #2 Zahn cup. Reduce with D5B9 Xylol (part number 21525038000) if needed. Air dry the primer for a minimum of 30 minutes, then apply the finish color coat of acrylic enamel. The top coat should be applied within 24 hours for best adhesion. If the area is to be spray-coated, thin the acrylic enamel with D5B9 Xylol (part number 21525038000). This thinning should only be necessary if the paint was received in a five gallon drum or more.

The recommended viscosity for the W42713 topcoat should be 24-32 seconds with a #2 Zahn cup. The curing schedule for PPG W42713 is dust free in 5 minutes, touch in 30 minutes, handle in 60 minutes, full cure in 7 days. Both the primer (Sherwin-Williams E61 A 60) and paint (PPG W42713) should be applied only when temperature is above 55 degrees Fahrenheit. Application of special paint will be per the manufacturer's Product Data Sheet which includes instructions on thinning and application.

9.7 Circuit breaker lifting mechanism

Under normal conditions, no special maintenance procedures or lubrication is required for this device. If the cable is abraided under any condition, it should be inspected for broken strands or other damage and replaced if necessary.

Appendix A - torque values

Table A.1

Torque values for low voltage equipment electrical joint hardware other than cable terminals (copper, tin or silver plated)

Hardware Size	Torque ^{1,2} (ft/lbs)
1/4-20	7-10
3/8-16	25-30
1/2-13	35-40
5/8-11	45-55

1. These torque values are for non-lubricated threads
2. Standard nut with conical spring washer or lock washer

Table A.2 - Torque values for cable terminals

Wire Size	Torque ¹ (in/lbs)
6	
5	
4	100
3	
3	
2	125
1	
0	150
00	
000	
0000	200
200.000	
250.000	
300.000	
350.000	250
400.000	
500.000	
600.000	
700.000	300
750.000	
800.000	
900.000	400
1.000.000	
1.250.000	
1.500.000	
1.750.000	500
2.000.000	

1. These torque values are for non-lubricated threads.

Appendix B - circuit breaker rejection features

—
Fig. A.1
Circuit breaker
pin assembly

—
Fig. A.2
Cassette block assembly

General

In general, draw-out breakers of the same type and rating are interchangeable in their equipment compartments; draw-out breakers of different types or short circuit ratings are intentionally made non-interchangeable. To prevent inserting the wrong breaker into a draw-out compartment, unique “rejection hardware” is affixed to each breaker and its cassette. The rejection is accomplished by pins on the sides of the breaker and the blocks on the sides of the cassette.

Rejection feature

This factory-installed, pin and gate device prevents the insertion of a circuit breaker into a cassette if the nominal rating of the breaker is incompatible with that of the cassette and its ancillary equipment.

The information in the following appendices lists the available rejection scheme combinations for the rejection feature. AKD-20 rejection combinations are in Appendix C and Entellisys rejection combinations are in Appendix D.



—
Fig. A.1



—
Fig. A.2

Appendix C - EntelliGuard G circuit breaker rejection features (AKD-20 Only)

Envelope 1 - ANSI circuit breaker

ANSI BR 800, P 100 kA

ANSI 1600, P 100 kA

ANSI 2000A, P 100 kA

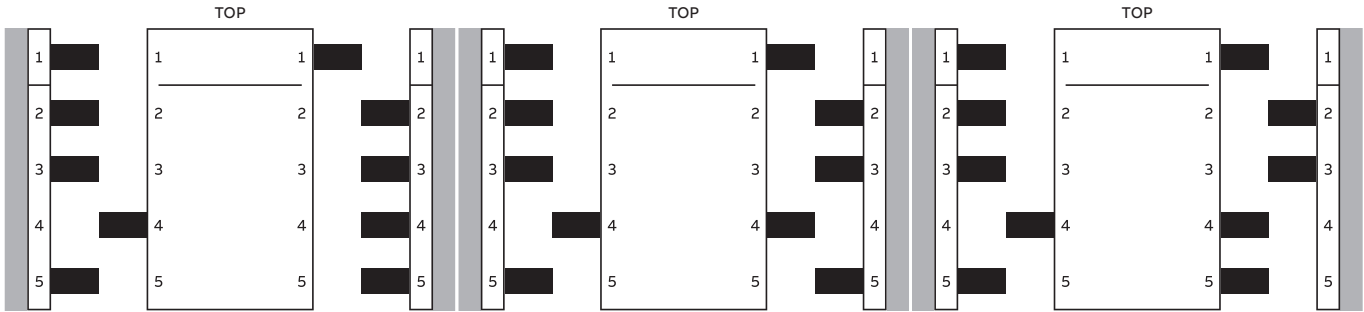

ANSI 800, H 85 kA

ANSI BR 1600, H 85 kA

ANSI BR 2000A, H 85 kA

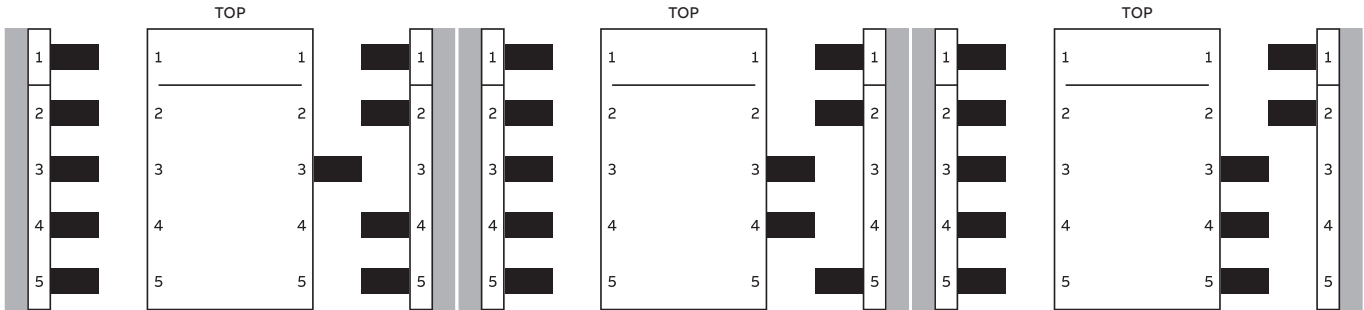

ANSI BR 800, N 65 kA SQ

ANSI BR 1600, N 65 kA SQ

ANSI BR 2000A, N 65 kA SQ

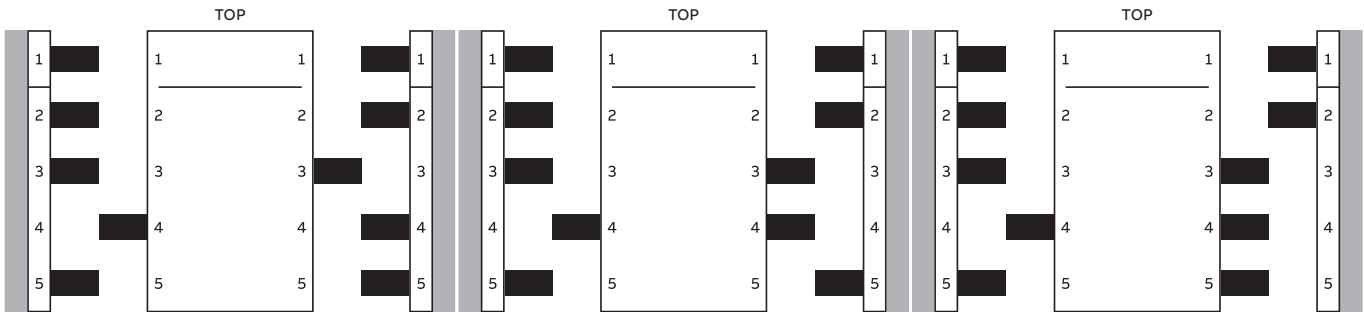

ANSI BR 800, S 65 kA

ANSI BR 1200, S 65 kA

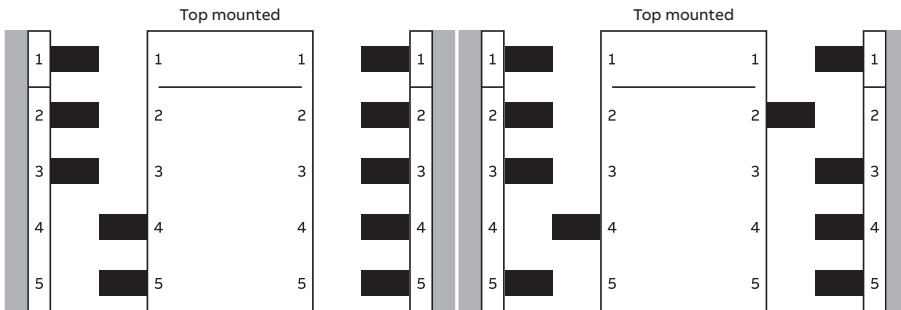

Envelope 1 - ANSI non-automatic switch

ANSI SW 800, H 42 kA

ANSI SW 1600, H 42 kA

ANSI SW 2000A, H 42 kA

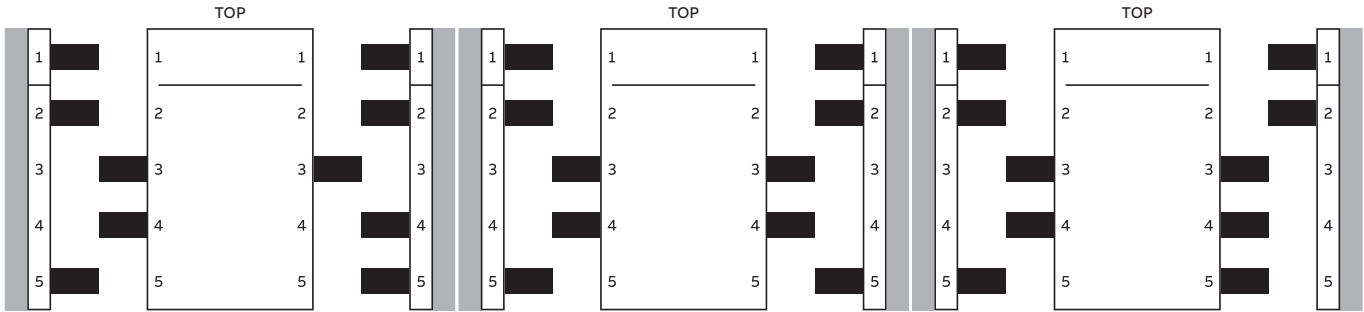

ANSI SW 800, S 42 kA

ANSI SW 1200, S 42 kA

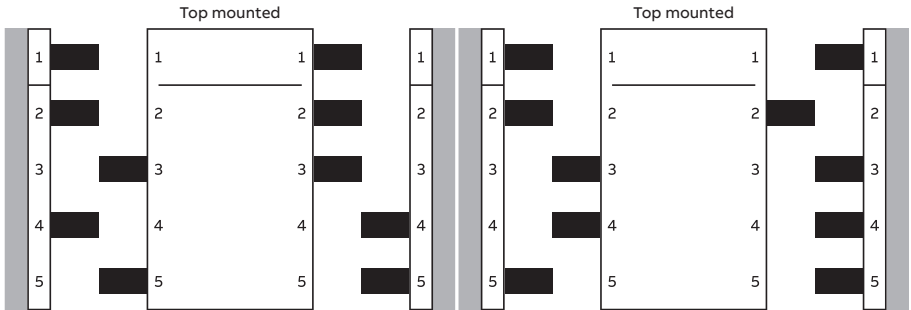

Envelope 2 (single cluster) - ANSI circuit breaker

ANSI BR 800, M 100 kA

ANSI BR 1600, M 100 kA

ANSI BR 2000, M 100 kA

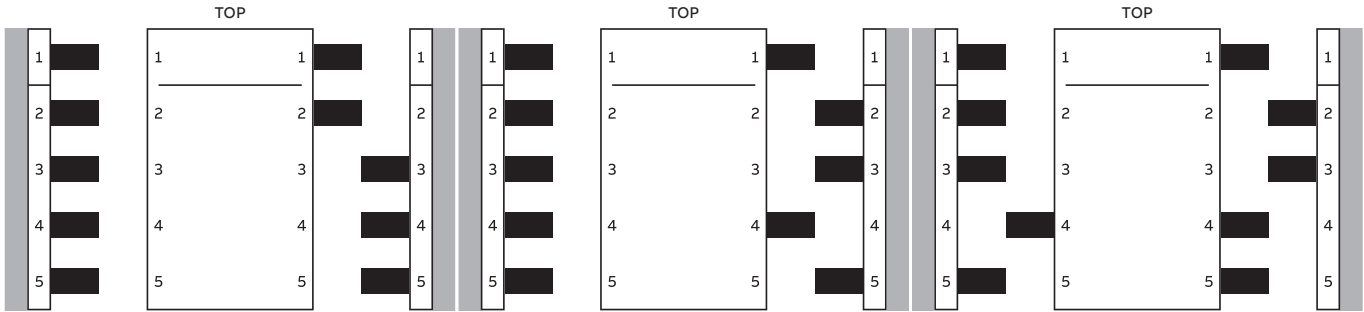

ANSI BR 800, E 85 kA SQ

ANSI BR 1600, E 85 kA SQ

ANSI BR 2000, E 85 kA SQ

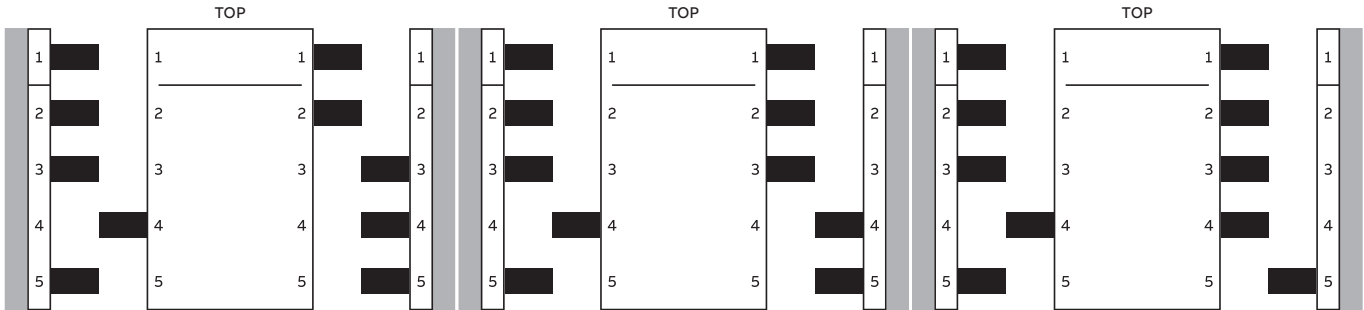

Envelope 2 (Single Cluster)

ANSI Non-Automatic Circuit Breaker

ANSI SW 800, M 65 kA

ANSI SW 1600, M 65 kA

ANSI SW 2000, M 65 kA

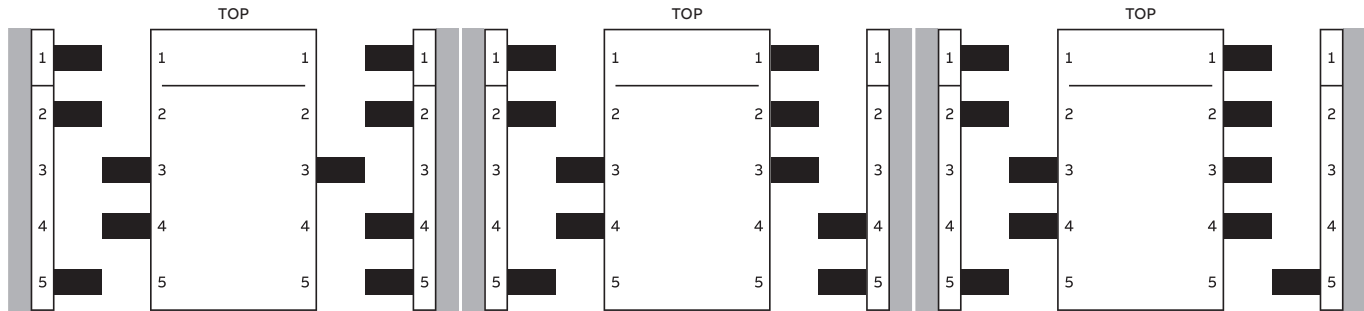

Envelope 2 (double cluster) - ANSI circuit breaker

ANSI BR 800, M 100 kA

ANSI BR 1600, M 100 kA

ANSI BR 2000, M 100 kA

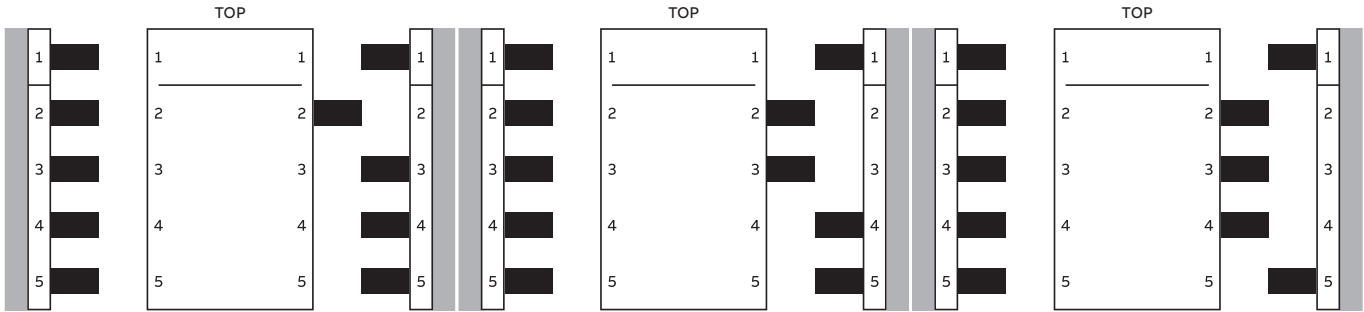

ANSI BR 800, E 85 kA SQ

ANSI BR 1600, E 85 kA SQ

ANSI BR 2000, E 85 kA SQ

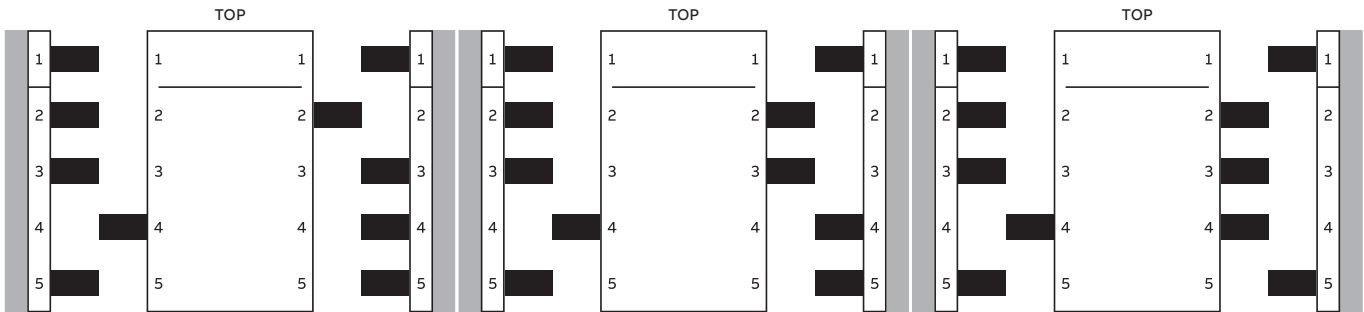

ANSI BR 3200A, M 100 kA

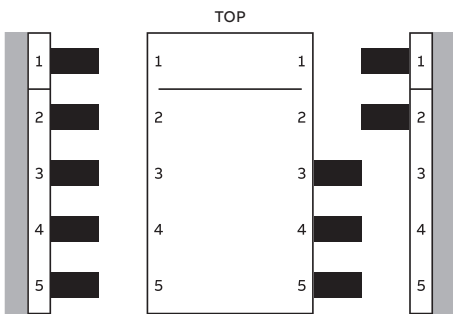

ANSI BR 3200A, E 85 kA SQ

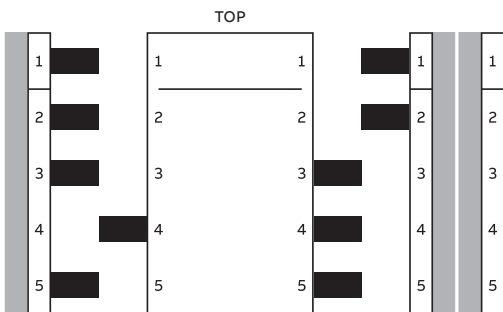

ANSI BR 3200, N 65 kA SQ

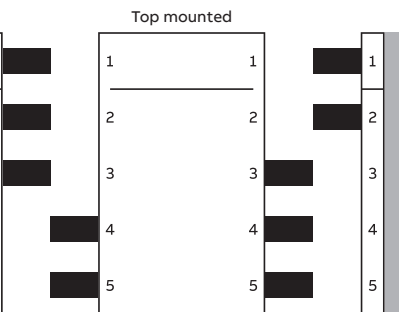

Envelope 2 (Double Cluster) - ANSI non-automatic circuit breaker

ANSI SW 800, M 65 kA

ANSI SW 1600, M 65 kA

ANSI SW 2000, M 65 kA

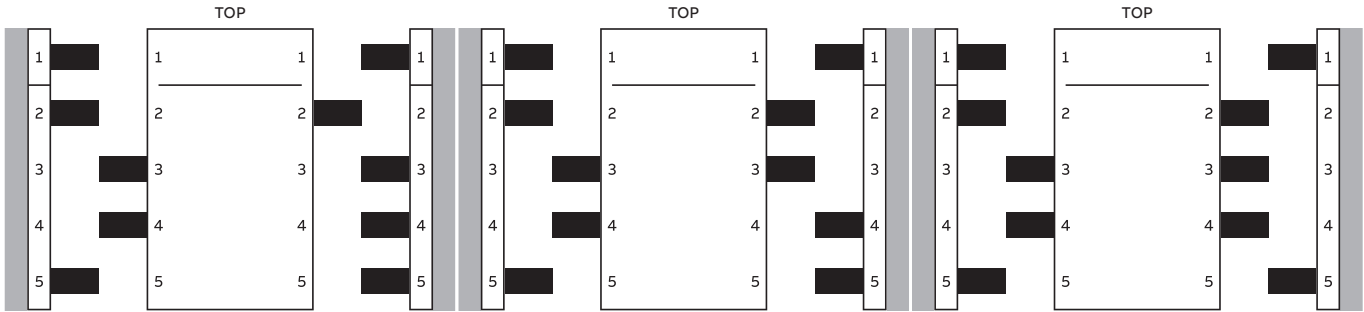

ANSI SW 3200, M 65 kA SQ

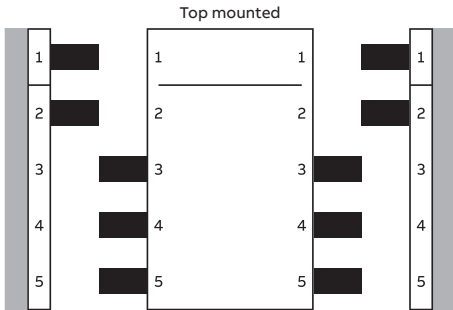

Envelope3 - ANSI circuit breaker

ANSI BR 3200, W 200 kA

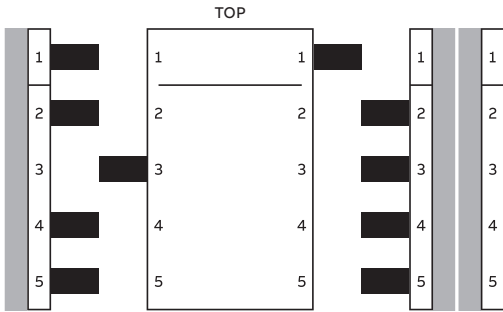

ANSI BR 4000, W 200 kA

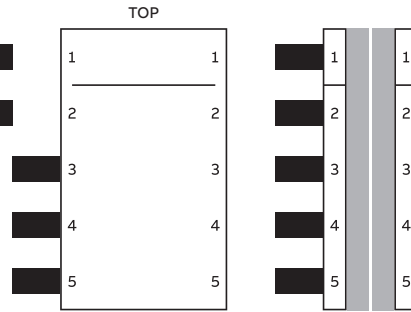

ANSI BR 5000, W 200 kA

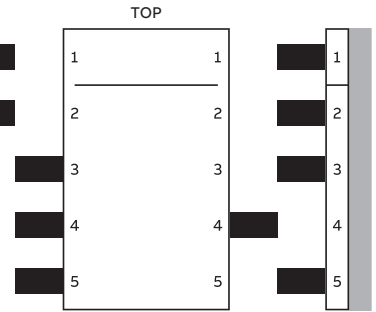

ANSI BR 3200, L 150 kA

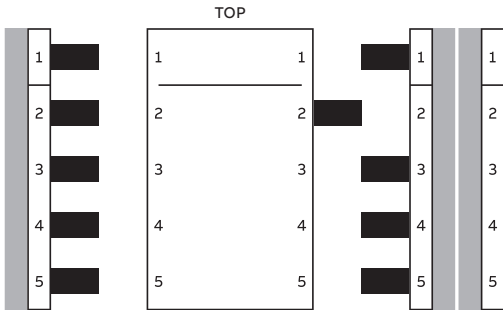

ANSI BR 4000, L 150 kA

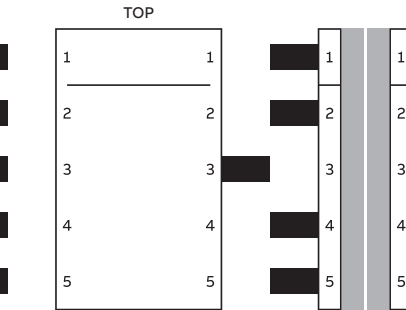

ANSI BR 5000, L 150 kA

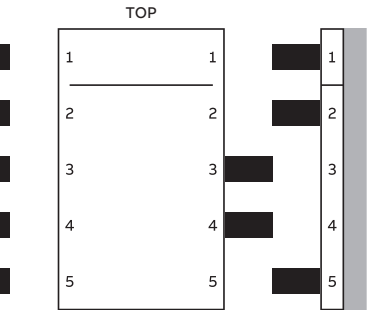

ANSI BR 3200, B 100 kA SQ

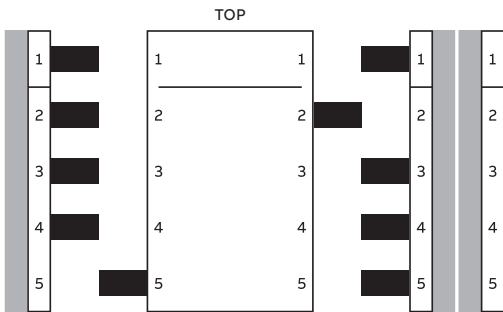

ANSI BR 4000, B 100 kA SQ

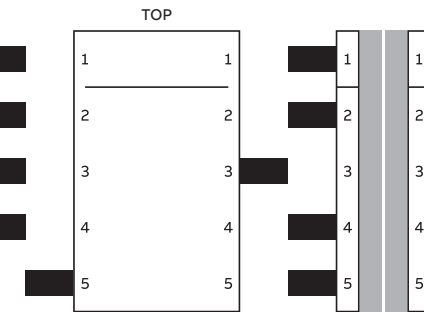

ANSI BR 5000, B 100 kA SQ

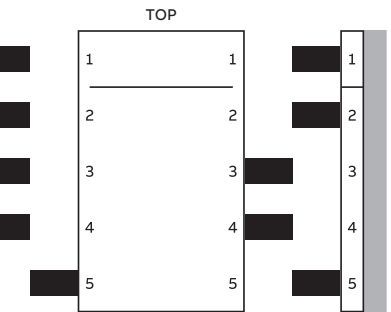

Envelope 3 - ANSI circuit breaker

ANSI BR 4000, M 100 kA

ANSI BR 5000, M 100 kA

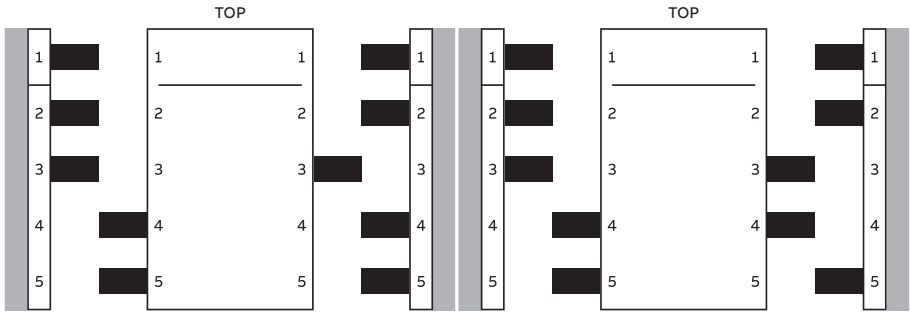

ANSI BR 4000, E 85 kA SQ

ANSI BR 5000, E 85 kA SQ

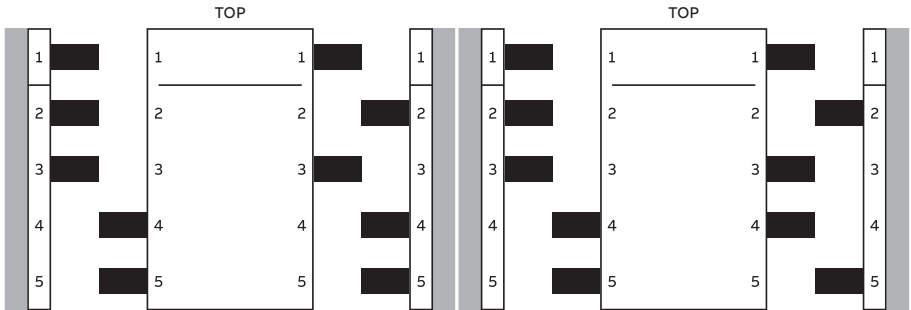

Envelope 3 - ANSI non-automatic circuit breaker

ANSI SW 3200, B 100 kA SQ

ANSI SW 4000, B 100 kA SQ

ANSI SW 5000, B 100 kA SQ

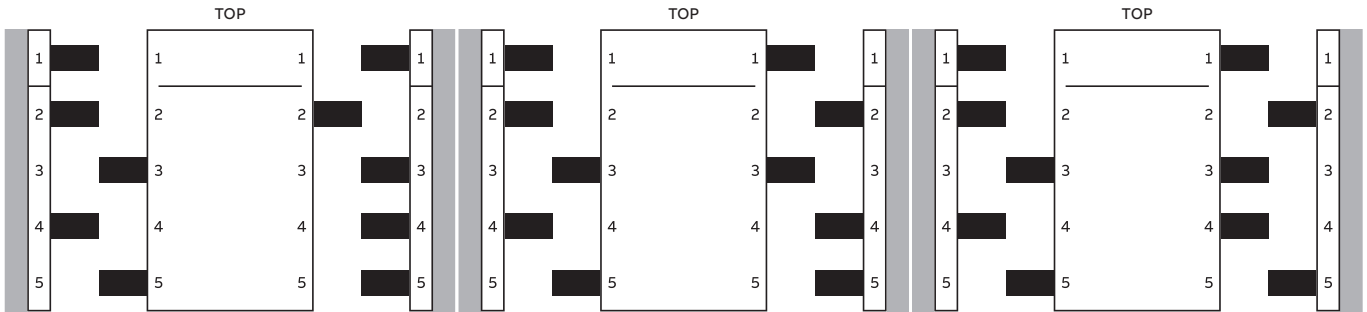

Appendix D - EntelliGuard E circuit breaker rejection features (Entellisys Only)

Envelope 1 - ANSI circuit breaker

Entellisys 800A, P 100 kA

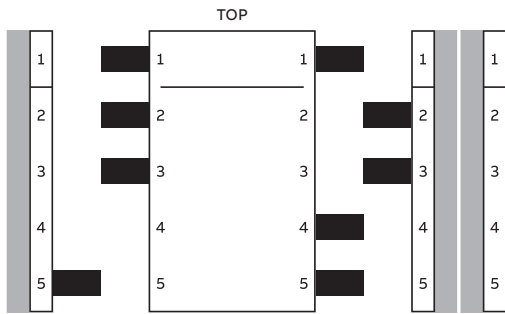

Entellisys 1600, P 100 kA

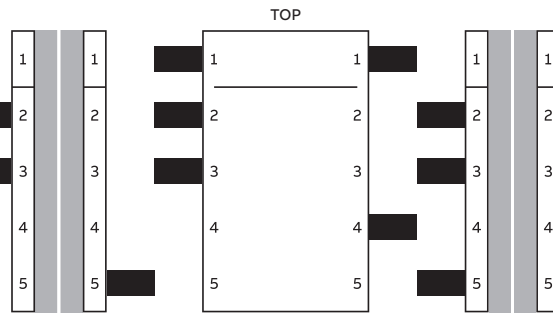

Entellisys 2000, P 100 kA

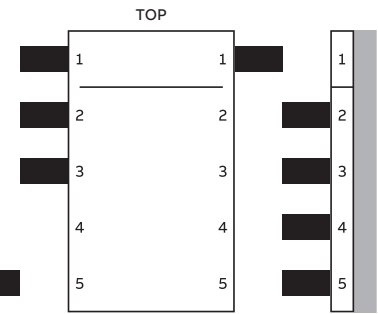

Entellisys 800A, H 85 kA

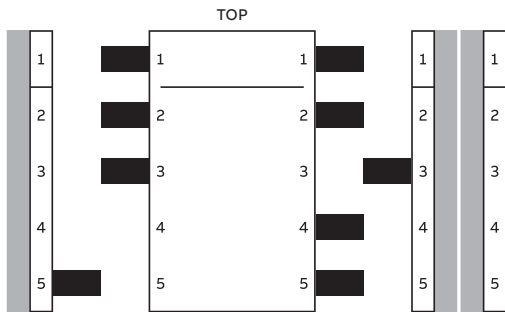

Entellisys 1600, H 85 kA

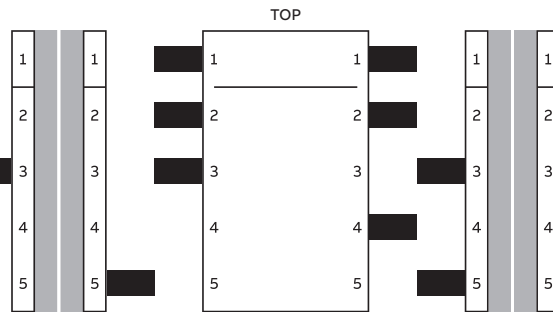

Entellisys 2000, H 85 kA

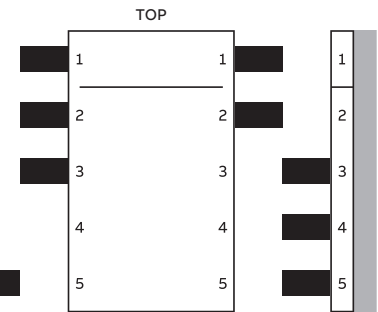

Entellisys 800A, N 65 kA SQ

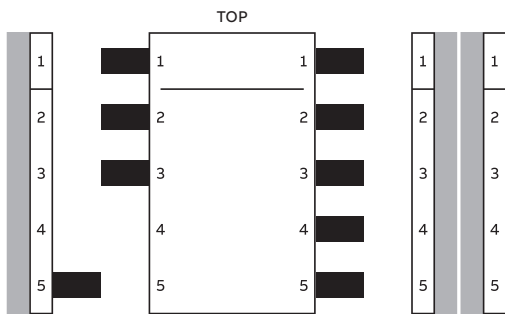

Entellisys 1600, N 65 kA SQ

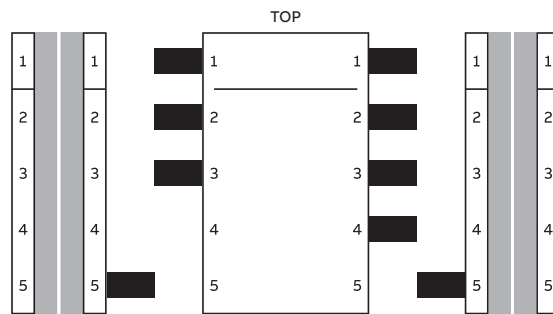

Entellisys 2000, N 65 kA SQ

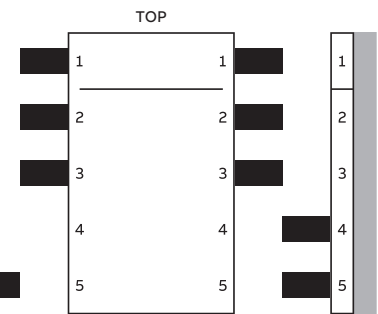

Entellisys 800, S 65 kA

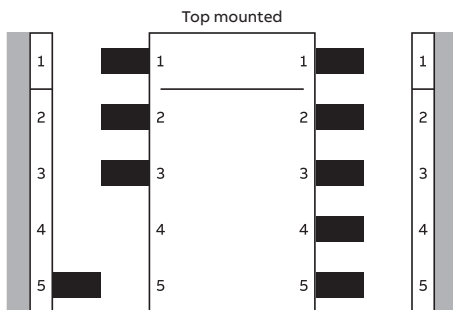

Envelope 2 (single cluster) - ANSI circuit breaker

Entellisis 800A, M 100 kA

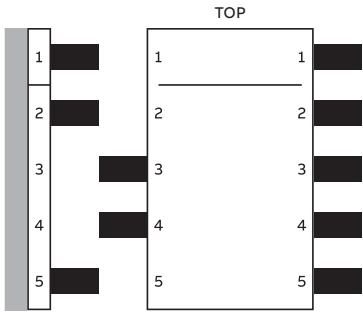

Entellisis 1600, M 100 kA

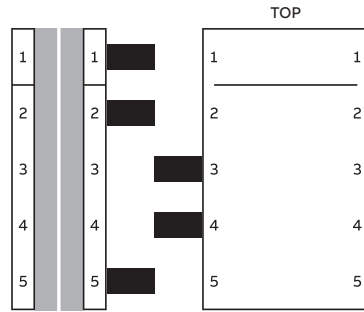

Entellisis 2000, M 100 kA

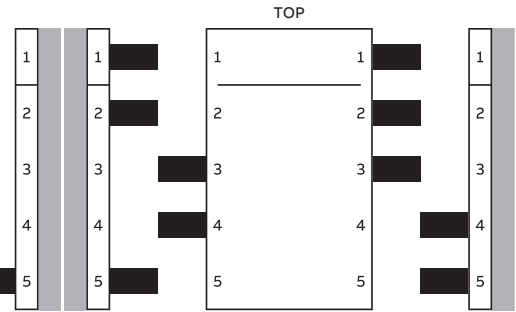

Entellisis 800A, E 85 kA SQ

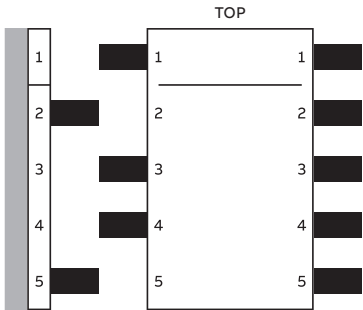

Entellisis 1600, E 85 kA SQ

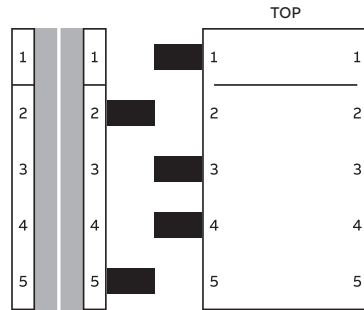

Entellisis 2000, E 85 kA SQ

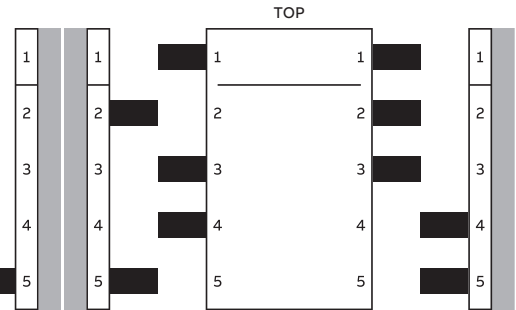

Envelope 2 (Double Cluster) - ANSI Circuit Breaker

Entellisys 3200, M 100 kA

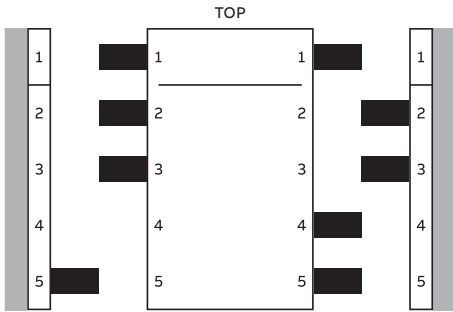

Entellisys 3200, E 85 kA SQ

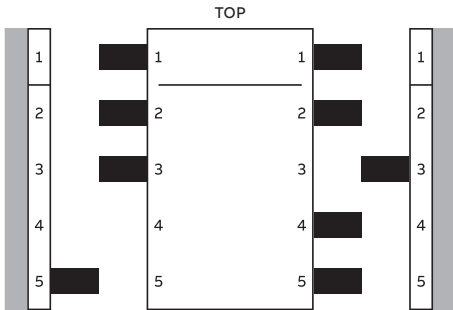

3200, N 65 kA SQ

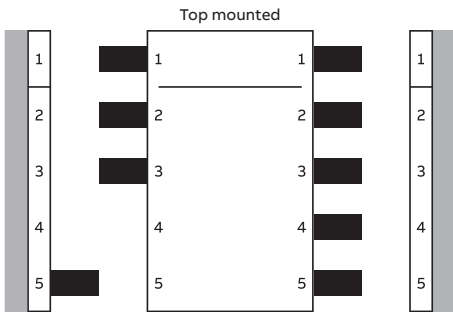

Envelope 3 - ANSI Circuit Breaker

Entellisy 3200A, W 200 kA

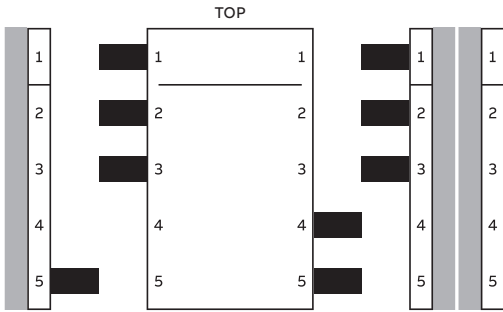

Entellisy 4000, W 200 kA

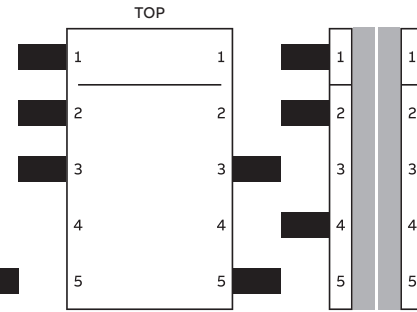

Entellisy 5000, W 200 kA

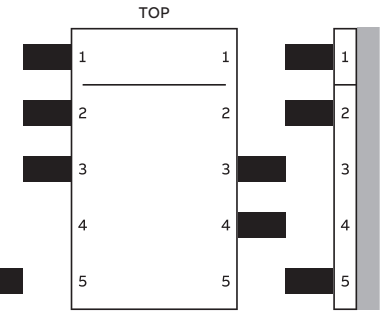

Entellisy 3200A, L 150 kA

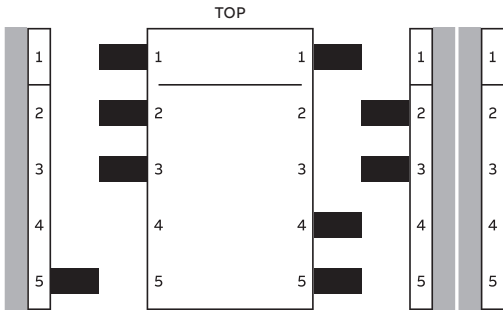

Entellisy 4000, L 150 kA

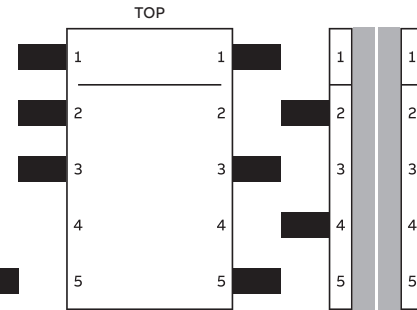

Entellisy 5000, L 150 kA

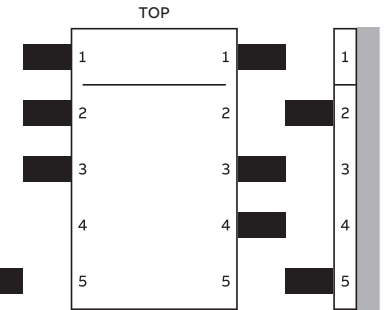

Entellisy 3200A, B 100 kA SQ

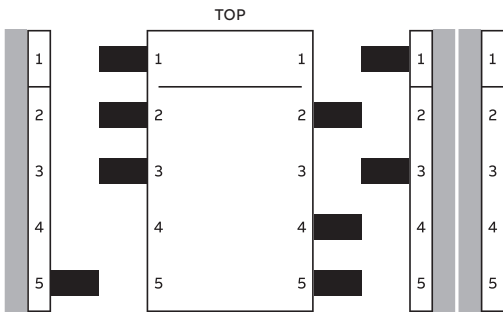

Entellisy 4000, B 100 kA SQ

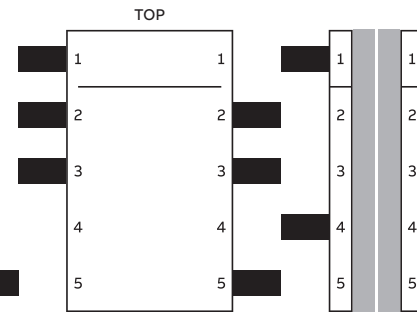

Entellisy 5000, B 100 kA SQ

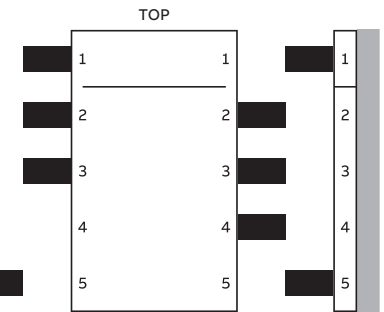

Envelope 3 - ANSI Circuit Breaker

Entellisy 4000, M 100 kA

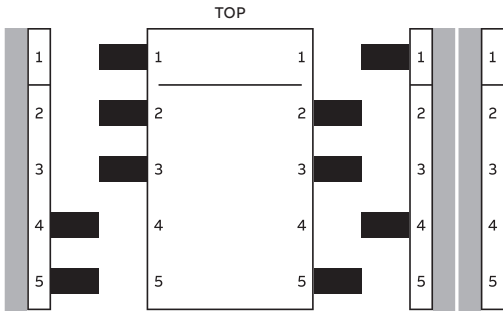

Entellisy 5000, M 100 kA

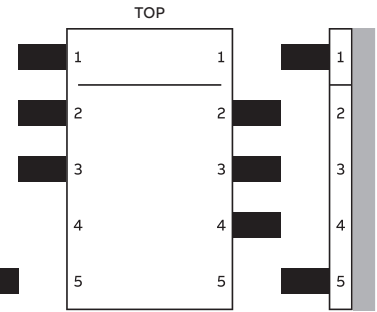

Entellisy 4000, E 85 kA

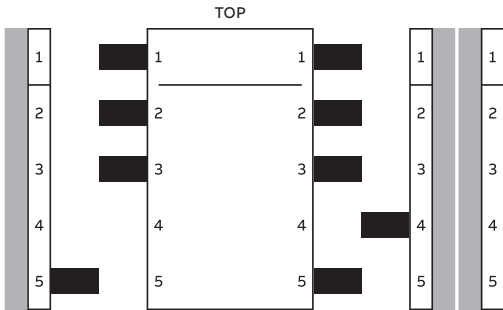

Entellisy 5000, E 85 kA

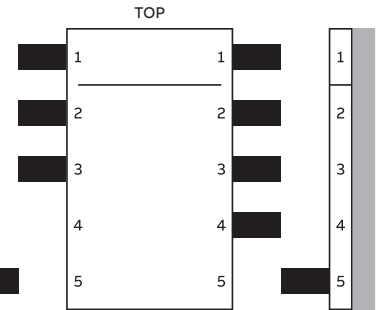

Appendix E - circuit breaker information

For all circuit breaker information, including ratings, weights, accessories, etc., reference DEH-41304 (AKD-20 Only) or DEH-41526 (Entellisis Only) at abb.com/lowvoltage. In Publication Library select publication number type in this DEH number and click Go.

—
ABB Inc.

305 Gregson Drive
Cary, NC 27511

abb.com/lowvoltage

**GE is a trademark of GE.
Manufactured by ABB Ltd
under license from General
Electric Company.**

The information contained in this document is for general information purposes only. While ABB strives to keep the information up to date and correct, it makes no representations or warranties of any kind, express or implied, about the completeness, accuracy, reliability, suitability or availability with respect to the information, products, services, or related graphics contained in the document for any purpose. Any reliance placed on such information is therefore strictly at your own risk. ABB reserves the right to discontinue any product or service at any time.

© Copyright 2019 ABB. All rights reserved.