

GE
Industrial Solutions

EntelliGuard* Retrofill Circuit Breakers 600-2000A AKD-5 Installation Manual

General Electric AKD-5 Low Voltage Switchgear is a free-standing assembly of metal-enclosed ANSI power circuit breakers. It may be a part of a single-ended or double-ended load center unit substation. This applies to EntelliGuard R breakers to replace AK-#A-25/50/T50 legacy circuit breakers and AKJ/AKJT/AKS/AKST legacy replacement breakers.



imagination at work

Table of Contents

| | |
|--|-----------|
| Preface | 3 |
| Hazards | 3 |
| Danger | 3 |
| Warning..... | 4 |
| Caution | 4 |
| Notice or Note..... | 5 |
| Warranty..... | 5 |
| Trademarks and Patents | 5 |
| Standards..... | 5 |
| Document Conventions..... | 5 |
| Related Publications..... | 6 |
| Service and Support..... | 6 |
| Estimated Time to Complete Tasks..... | 6 |
| Description | 6 |
| Product Specs | 6 |
| Weight (lbs) | 7 |
| Views..... | 7 |
| History and Types..... | 8 |
| AKD | 9 |
| AKD-5—AK25/AK50 | 9 |
| Unpack Retrofill Circuit Breaker | 11 |
| Quality | 12 |
| Information Label..... | 12 |
| Product and Catalog Serial Numbers | 12 |
| Remove Circuit Breaker from Container | 12 |
| Inspect | 12 |
| Use Lifting Truck..... | 12 |
| Store Circuit Breaker | 14 |
| Check Before Installing | 15 |
| Clean and Grease Breaker..... | 15 |
| Customize Retrofill Secondary Wiring | 16 |
| Modify AKD-5 Switchgear Compartment | 16 |

| | |
|---|-----------|
| Cut Power | 16 |
| Rack Out Legacy Breaker | 17 |
| Empty Compartment—Legacy Breaker Removed..... | 17 |
| Check, Clean, Grease Compartment..... | 17 |
| Install Position Switch Actuator—AK25 Breaker | 18 |
| Install Position Switch Actuator—AK50 Breaker | 19 |
| Racking-Lock Bracket—Initial Tasks..... | 20 |
| Install Cassette (Landed Wires)..... | 22 |
| Install Lock Bracket..... | 24 |
| Install AKD-5 Retrofill Breaker..... | 26 |
| AK/AKT-50 - Key Interlock..... | 34 |
| Secondary Disconnects, Bullets | 34 |
| Wiring Diagram and Block Info (AK25)..... | 35 |
| AK25 Wiring Harness, B-Block (AK25/50)..... | 37 |
| Programmer Secondary Disconnect (Breaker Side—N/A) | 39 |
| AK25..... | 39 |
| Install Door Interlock System (Breaker Side)..... | 40 |
| Neutral Disconnect Assembly (Breaker Side)..... | 40 |
| Install AKD-5—Neutral Rogowski Current Transformer (CT) | 40 |
| Remove Existing Iron Core Neutral CT Assembly..... | 41 |
| Neutral CT assembly in Cable/Bus Compartment:..... | 41 |
| AKD-5—Neutral Sensor Packaging | 43 |
| AKD-5—Multi-Source Ground Fault | 44 |
| Remove and Replace AKD-5—Existing Door | 45 |
| Wiring Diagram for the AK/AKR Retrofill..... | 48 |
| Notes..... | 48 |

Preface

Hazards

The following important highlighted information appears throughout this document to warn of potential hazards or to call attention to information that clarifies a procedure. Carefully read all instructions and become familiar with the devices before trying to install, operate, service, or maintain this equipment.


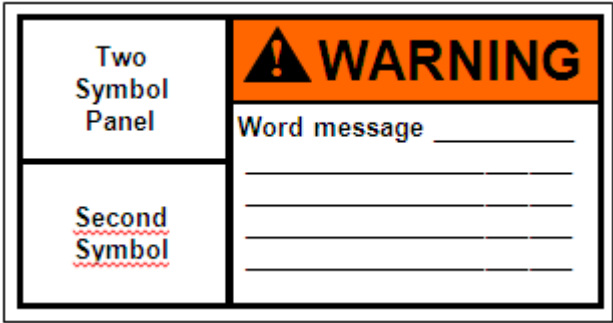
Danger

This indicates a hazardous situation which, if not avoided, results in death or serious injury. A variety of electrical hazards warnings are displayed here and are applied to installation manuals. These are standard or generic alerts and labels that must be taken quite seriously when installing Retrofill circuit breakers in AKD switchgear and when working with potentially dangerous electrical equipment ([Table 1](#)). There are also dangers, pertaining to product safety, that need to be custom-written for particular or specific circumstances ([Table 2](#)).

| Table 1. <u>Generic</u> Danger Alerts and Labels Used for Documentation and Dangerous Equipment | Table 2. <u>Custom</u> Danger Alerts and Labels Used for Documentation and Dangerous Equipment |
|---|--|
| | |

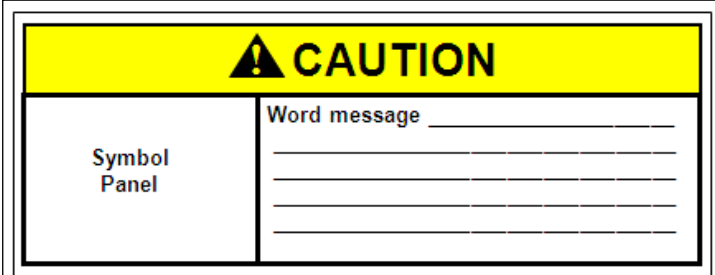
Warning

This indicates a hazardous situation, which, if not avoided, would result in death or serious injury. A variety of electrical hazards warnings are displayed here and are applied to installation manuals. These are standard or generic alerts and labels that must be taken quite seriously when installing Retrofill circuit breakers in AKD switchgear and when working equipment that can cause injury, but may not be necessarily fatal (Table 3). There are also warnings, pertaining to product safety, that need to be custom-written for particular or specific circumstances (Table 4).

| Table 3. <u>Generic</u> Warning Alerts and Labels Used for Documentation and Dangerous Equipment | Table 4. <u>Custom</u> Warning Alerts and Labels Used for Documentation and Dangerous Equipment |
|--|---|
|  |  |

Caution

This pertains to a hazard that has a low level of risk, which means that if not avoided, it could result in minor or moderate injury. It also indicates that failure to comply with instructions may result in product damage. The label here requires a specific message that targets a special product or procedure (Table 5).

| Table 5. <u>Custom</u> Caution Alerts and Labels Used for Documentation and Operating Equipment | |
|---|--|
|  | |

Notice or Note

This indicates important information in that it aids in job performance, that is, a notice or note is used to notify practices not related to personal injury ([Table 6](#)).

| Table 6. <u>Custom</u> Notice Alerts and Labels Used for Documentation and Operating Equipment |
|--|
| <p>Not considered a safety label</p> <div style="border: 1px solid black; padding: 10px;"><div style="background-color: #0070C0; color: white; text-align: center; padding: 5px;">NOTICE</div><p>Word message _____</p><p>_____</p><p>_____</p><p>_____</p></div> |

Warranty

This document is based on information available at the time of its publication. While efforts have been made to ensure accuracy, the information contained herein does not cover all details or variations in hardware and software, nor does it provide for every possible contingency in connection with installation, operation, and maintenance.

Features may be described herein that are not present in all hardware and software systems. GE Energy assumes no obligation of notice to holders of this document with respect to changes subsequently made. GE Energy makes no representation or warranty, expressed, implied, or statutory, with respect to, and assumes no responsibility for the accuracy, completeness, sufficiency, or usefulness of the information contained here in. Not warranties of merchantability or fitness for purpose shall apply.

Contact your local sales office if further information is required concerning any aspect of EntelliGuard R Circuit breaker operation or maintenance.

Trademarks and Patents

EntelliGuard® R
EntelliGuard® TU
EntelliGuard® Trip Unit
EntelliGuard® G

Standards

| Agency Certification | |
|---------------------------------|---|
| Standard Number | Title |
| ANSI C37.13,16,17,20.1,50,51,59 | Low-Voltage AC Power Circuit Breakers |
| UL 1066 | Low-Voltage AC and DC Power Circuit Breakers Used in Enclosures |

Document Conventions

Topics and text are divided into primary, secondary, and tertiary paragraph headings.

Related Publications

| Publication | Publication Number |
|--|--------------------|
| Brochure | DEA-532 |
| Snapshot | DEE-543 |
| Installation Manual AKD-10 | DEH-41550 |
| Installation Manual AKD-8 | DEH-41549 |
| Installation Manual AKD-6 | DEH-41548 |
| Installation Manual AKD-5 | DEH-41547 |
| Accessory: Door Interlock (Door Interlock Kit) | DEH-41529 |
| Accessory Retrofill Doors Assembly | DEH-41563 |
| Accessory: Position Switch Plate & Position Switch Assembly & Wiring (Position Switch Kit) | DEH-41530 |
| Accessory: Neutral Rogowski CT Disconnect (Neutral Assemblies) | DEH-41531 |
| Accessory: Programmer Disconnects | DEH-41532 |
| Accessory: Finger Clusters (Cluster Assemblies) | DEH-41533 |
| Accessory: Secondary Disconnects | DEH-41534 |
| FAQ | DEQ-171 |
| Application Guide | DET-753 |
| Guideform Spec | DET-754 |
| Spare/Renewal Parts Guide | DET-755 |

Service and Support

In addition to the local field sales office and service teams, GE also has a dedicated Aftermarket team to assist customers with legacy information, selection, ordering, and upgrading.

Estimated Time to Complete Tasks

It takes about 20 minutes to install a feature-for-feature LSI assembly. This includes racking out the old breaker, racking in the new breaker, and replacing the door. If new options are desired, or if it's a 4-wire LSI circuit or modifications are needed to the cubicle, then additional time is required. Time also does not include wiring the secondary disconnect on the retrofill.

Description

Product Specs

General Electric AKD-5 Low Voltage Switchgear is a free-standing assembly of metal-enclosed ANSI power circuit breakers. It may also be a part of a single-ended or double-ended load center unit substation. Figure 1 shows the retrofill circuit breaker projected out of its cassette. [Figure 2](#) shows the AK25 retrofill breaker in the cassette.

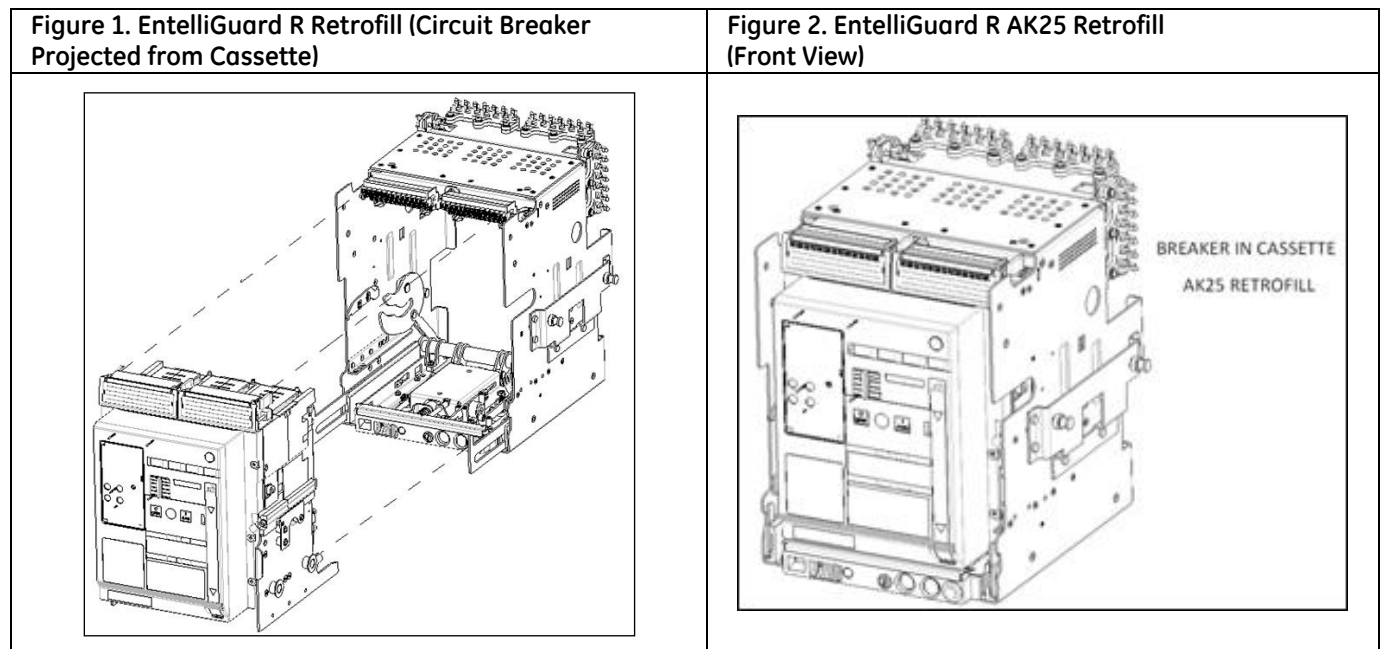
Weight (lbs)

| Retrofill Breaker | Weight | Box Weight 10101653P1 | Pallet 10101650P1 Wt | Accessories Wt | Total Weight |
|-------------------|--------|-----------------------|----------------------|----------------|--------------|
| AK25 | 197 | 16 | 33 | 2 | 248 |

| Retrofill Breaker | Weight | Large Frame Box Wt 10101653P1 | Pallet 10101513P1 Wt | Accessories Wt | Total Weight |
|-------------------|--------|-------------------------------|----------------------|----------------|--------------|
| AK25 | 200 | 11 | 24 | 2 | 237 |
| AK50/T50 | 289 | 11 | 24 | 2 | 326 |

| Retrofill Breaker | Weight | Box Weight 10101655P1 | Pallet 10101650P1 Wt | Accessories Wt | Total Weight |
|-------------------|--------|-----------------------|----------------------|----------------|--------------|
| AK50/T50 | 289 | 18 | 33 | 2 | 342 |

Views



A rear view of the AK25 is featured in [Figure 3](#). Figure 4 shows the AK25 without its cassette.

Figure 3. EntelliGuard R AKD-5—AK25 Retrofill (Rear View)

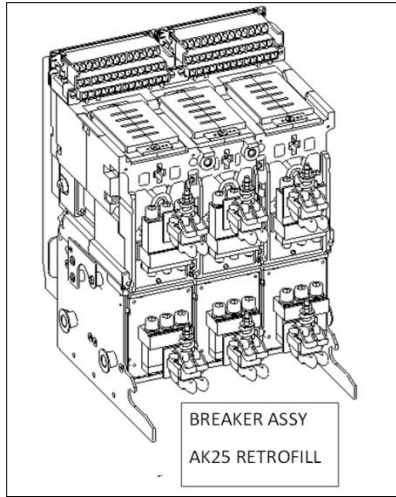


Figure 4. AKD-5—AK25 Retrofill Breaker without Cassette (Front View)

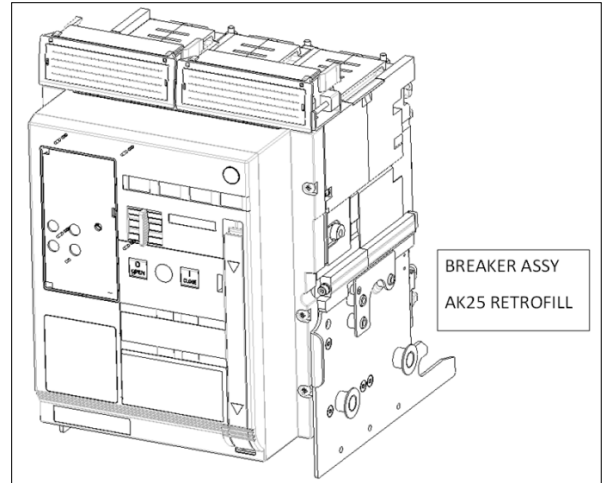


Figure 5 shows a rear view of the AKD-5—AK25 retrofill cassette, or substructure, without the breaker; Figure 6 shows a front view of the cassette.

Figure 5. AKD-5—AK25 Retrofill Breaker Cassette Assembly (Rear View)

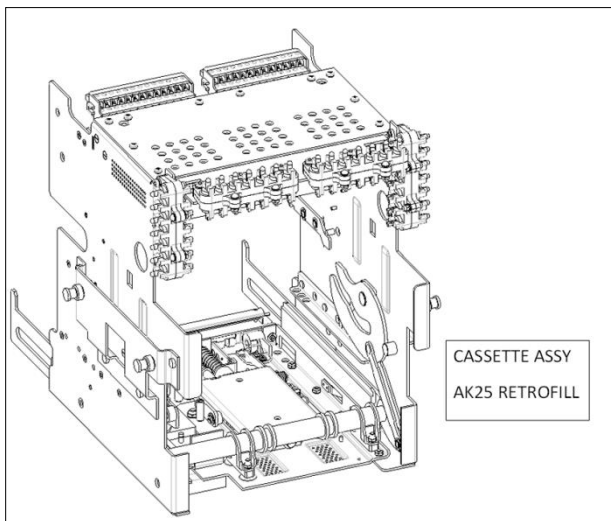
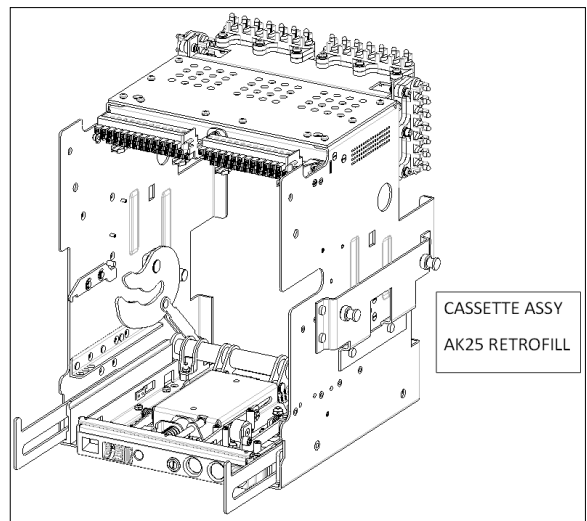


Figure 6. AKD-5—AK25 Retrofill Breaker Cassette Assembly (Front View)



The EntelliGuard R Circuit Breaker is suitable for application on power systems up to 600 VAC 50/60 Hz.

History and Types

AKD

AK—Power Circuit Breaker Equipment
D—Drawout circuit breaker construction

Manufactured from 1951 to 1975, all bolted, copper bus design, all drawout breakers—AK-1, —2, —3,—15 / 25 / 50 / 75 / 100; the 4000A-max bus rating. Breakers had a ratcheting drawout mechanism, with an open-door drawout. Breakers were painted ANSI 61, light gray, manufactured in Philadelphia from 1951 to the mid-60s and in Burlington, Iowa from the mid-60s to 1975.

The breaker compartment was a welded assembly, and the equipment frame was bolted. Breaker boxes were stacked to make a vertical section with equipment frame around the breaker boxes. There were no bus compartment barriers, just an open bus design. Ring silver-plating was applied to bolted connections.

AKD-5—AK25/AK50

Manufactured from 1960 until 1977, the aluminum bus had copper that was “flash-butt welded” to the aluminum at bolted connections. During that time, AK-2A, 3A -25 / 50 / T50 / 75 / 100 (“A” signifies AKD-5 drawout) were produced. Breakers up to 2000A had primary finger clusters. 3000 & 4000A breakers had a circular primary finger cluster arrangement in the switchgear compartment. Pull-lanyard drawout mechanism in the switchgear on early designs was replaced by a single jackscrew mechanism and then later replaced by a double jack-screw mechanism. Featured is a closed-door, drawout with inner house breaker compartment, where door moves out with the breaker as it is racked in or out. Two bus levels are available with a ring bus used at 4000A. Particulars include: welded/riveted frame, bus compartment barriers, line/load separation barriers on mains and ties, isolation barriers on transformer transitions, copper runbacks on feeder breakers, ring silver-plating on copper, and aluminum bus unplated (welded connections). The switchgear is painted sand-gray (beige), with some instrument doors painted blue. AKR-30/50 in 22”-wide sections were introduced in AKD-5 construction, early 70s. AK25s and AK50s were also available as substructure kits for OEMs to build around customer gear.

Note: All legacy AK & AKR breakers have a draw out letter code “A”. EntelliGuard R retrofill breakers for this gear will have a catalog number beginning with **R1** for AK replacements or **R2** for AKR-30/50 replacements.

AKD-6—AKR30H/AKR30L/AKR50H/AKRT50H

The AKD-6 was manufactured in Salisbury, NC from 1977 to 1981. Some AKD-5s, which were built in Salisbury from 1975 until 1977, got name-plated as AKD-6. There is no “flash-butt” welded aluminum to copper. Aluminum bus is tin-plated and bolted at shipping splits (but welded everywhere else). Copper bus design has ring silver plating at bolted joints. AKR-75 / 100s were introduced during this time. Stab-and-finger connections on 3200A and 4000A breakers were improvements, versus the round the primary disconnects on the AKD-5.

The AKD-6 uses inner-house drawout breaker compartments on the 800—2000A breaker compartments. They are painted ANSI 61 light gray and breakers have ECS or SST trip units.

AKD-6 should mark a shift away from all AK breakers and to AKR breakers. The AKR-30/50/50H/T50 breakers used in AKD6 have a shallow 1” steel front escutcheon are drawout letter code “A” i.e. AKR-4A-30 and will be replaced by an EntelliGuard R with a catalog number beginning with **R2**. The AKR-30/50/50H/T50 breakers sold to OEMs for their switchgear have a 5” deep plastic front escutcheon &

spring loaded sliding “picture frame”. These are draw out letter code “B” i.e. AKR-4B-30 which will be replaced by an EntelliGuard R with a catalog # beginning with **R5**.

AKD-8—AKR30H/AKR30L/AKR50H/AKRT50H

The AKD-8 was manufactured in Salisbury, NC from 1980 to 1984 and in Burlington, Iowa from 1984 to 1999. It was mostly replaced by AKD-10 in 1999 to 2000 but was available thru 2015. Model 1 and 2 have extruded vertical bus. Model 2 was introduced in 1983 to accommodate revised wire harness routing. Model 3 was introduced in 1991, using a flat bar vertical bus. AKR breakers use MicroVersaTrip 9, MVT RMS9, EPIC, MVT Plus, MVT PM, or EntelliGuard TU trip units. Aluminum bus was removed from the design in 1996 in favor of the standard tin-plated copper bus (silver plated optional).

The AKR-30/50/50H/T50 breakers used in AKD8 have 5” deep plastic front escutcheon & spring loaded sliding “picture frame”. They are drawout letter code “D” i.e. AKR-7D-30. In AKD-8, most 800-2000A breakers are “feeder” breakers with vertical lower stud & primary disconnect fingers clusters, but 800-2000A breakers designated as “Main” breakers, have horizontal lower finger clusters, which is the same as “D” letter code breakers sold to OEM’s. A lower stud rejection bracket differentiates between lower stud orientations. EntelliGuard R breakers with a catalog number beginning with **R3** replace an AKR-30/50/50H/T50 breaker with vertical lower stud & fingers. EntelliGuard R breakers with a catalog number beginning with **R6** replace an AKR-30/50/50H/T50 breaker with horizontal lower stud & fingers.

AKD-10—WPS-08, WPH-08, WPX-08, WPS-16, WPH-16, WPS-20

AKD-10 was manufactured in Burlington, IA from 1999 thru 2015. The switchgear compartment sizes and main & vertical bus arrangements are the same as AKD-8 Model 3. The compartments have pull-out rails. AKD-10 uses WavePro * drawout-only style breakers. All breakers have 4 rollers which align with the compartment rails. The secondary control wiring for all functions is connected thru either one or two 36 point secondary disconnects with gold plated contacts. Secondary control wiring terminates at fixed standard locations on the 36 point disconnects. Each breaker has a pump style manual charging handle and manual push OPEN and Push CLOSE buttons. The front escutcheon is 5” deep with a sliding picture frame, but is wide enough so the trip unit and new style bell alarm are visible thru the front door of the switchgear. EntelliGuard R breakers with a catalog number beginning with **R7** will replace a WavePro breaker with a catalog number beginning with WE or W1. EntelliGuard R breaker with a catalog number beginning with **R8** will replace a WavePro breaker with a catalog number beginning with WS or W2. Note GE Switchboard plants initially shipped “WS” style breakers and later shifted to “WE” style breakers to be consistent with GE Switchgear from Burlington, Iowa.

Unpack Retrofill Circuit Breaker

By following the procedures below, one should be able to install the breaker with minimum effort and time.



Turn off all power to switchgear. Tagout and lockout main source, up-stream or main breaker.

Failure to comply with these instructions will result in death or serious injury from severe burns caused by arc flashing that has exceedingly high temperatures.

Always wear personal protection equipment according to OSHA standards and appropriate to the severity of potential burns.

- Ensure only qualified personnel install, operate, service, and maintain all electrical equipment.



Falling Object

- Do not walk or remain under any heavy assembly while hoisted above head as the chains securing the assembly may give way

- Ensure lifting equipment has capability for device being lifted.
- Wear hard hat, gloves, and safety shoes.
- Failure to comply with these instructions could result in serious injury.



PRODUCT DAMAGE

- Ensure circuit breaker and its accessories are always used within their designated ratings.
- Do not allow the circuit breaker to hit a hard surface while handling.
- Do not drag or slide the circuit breaker across a hard or rough surface

- A factory-installed rejection feature prevents mismatching circuit breakers and cassettes/substructure, preventing the insertion of a circuit breaker with a lower rating into a higher rated cassette/substructure, or the insertion of a higher rated circuit breaker into a lower

rated cassette/substructure.

Quality

All EntelliGuard R circuit breakers have been designed and manufactured to ANSI standards. The design was based on the original requirements from the Legacy Switchgear and Breaker. The product is assembled in the Burlington, Iowa factory; and is inspected using the same master gauges used on the legacy AK, AKR breakers to confirm electrical and mechanical performance, including rejections-features.

Information Label

On the side wall of each circuit breaker there is a detailed factory-assembled, side label that details all features included on both the circuit breaker and on the trip unit.

Product and Catalog Serial Numbers

Product and catalog serial numbers should be kept handy when communicating about the circuit breaker. Each circuit breaker has a unique serial number located on the left side (viewed from front) of the front fascia.

Remove Circuit Breaker from Container

Inspect

1. Inspect the shipping container for obvious signs of rough handling and/or external damage incurred during transportation.
2. Record any observed damage for reporting to the carrier. Ensure all recorded reports and claims include the order number and name plate information.
3. Remove the banding straps and lift off the top cover.
4. Remove all packaging material.
5. Remove all product documentation and store properly.
6. Unscrew the mounting screws that fasten the circuit breaker to the bottom of the shipping palette and remove the circuit breaker.

Use Lifting Truck

1. Use a lifting truck to lift and mount the assembly to avoid personal injury or damaging the breaker.
2. Contact the nearest sales office for availability of a hoisting device.
3. Avoid using hooks and chains since hooks can damage the fascia of the circuit breaker. Lifting bars are available from GE.
 - AK retrofit breakers use the EntelliGuard G lifting device.
 - AKR retrofit breakers use the legacy AKR lifting bar.
4. Pull out the ears of the Retrofit breaker so that the lifting bar can be inserted through the ears for hoisting breaker ([Figure 7](#)).

Figure 7. AKD-5—Breaker Lifting Holes

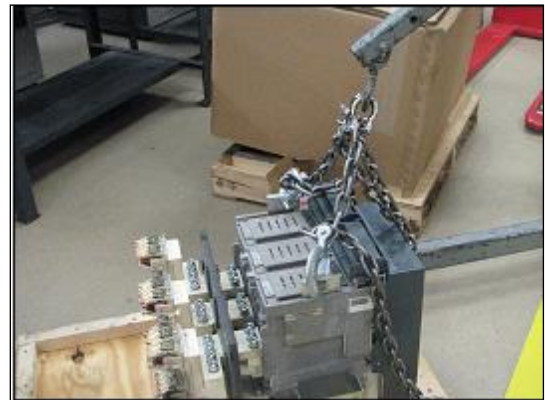


- 5. Avoid using hooks and chains since hooks can damage or bend the “ears” as well damage the fascia. Below are two examples of how not to handle the breaker ([Figure 8](#) and [Figure 9](#)).

Figure 8. Crane Lifting Hooks Can Damage Lifting Holes and Ears




Figure 9. Chains Can Damage Fascia and Ears



Store Circuit Breaker

If you decide not to install the retrofit breaker until a later time, then you can store it away for installing later.

| | |
|--|---|
|  <p>NOTICE</p> | <p>PRODUCT DAMAGE</p> <p>Do not store circuit breaker in corrosive environments above LC1 (sea salt mist) and G1 as per ANSI/ISA-S71.04-1985.</p> <ul style="list-style-type: none">• Ensure circuit breakers and cassettes are stored in a clean, dry location, in their original packaging.• Failure to comply with these instructions may result in product damage. |
|--|---|

1. Store the circuit breakers in a clean, dry location in an upright position.
2. Make sure that the breakers are properly supported to prevent bending of the studs or damaging any of the breaker parts. Do not remove any protective grease until the breaker is ready to be installed. Cover to prevent dust from settling on the breakers if they are not left in their original containers.
3. If breakers are not to be placed in service immediately, remove them from their shipping cartons and thoroughly inspect them.
4. If everything is in satisfactory condition, replace the breakers into their shipping cartons for storage. If it is necessary to store the equipment for any length of time, follow these precautions to prevent corrosion or deterioration.
5. Uncrate the equipment and check thoroughly for damage.
6. Store in a clean, dry, rodent-free location with moderate temperature and provide protective coverings to prevent dirt, water, or other foreign substances from entering the breaker.
7. If dampness or condensation is encountered in the storage location, heaters can be used to prevent moisture damage.

Check Before Installing



- It must be ensured that the supply power to the compartment is turned off/ compartment is de-energized for all the incoming and outgoing circuits of the LVS prior to any work being conducted on it.
 - During the installation and related work on the equipment, it must be ensured that the operator is using the prescribed PPE for the specified tasks.
- **Ensure only qualified personnel install, operate, service, and maintain all electrical equipment.**


These retrofit breakers are designed to rack into a special Cassette with a hollow back. The special cassette is equipped with AK style 7 point bullet connectors which interface with the original AKD-5 secondary disconnect blocks. The cassette also has a new racking mechanism. Two cams in the cassette engage pins on the new breaker to pull it into the cassette. The new breaker has primary disconnect fingers which will directly connect to the primary stab tips in the AKD-5 switchgear.

1. Check to see that the breaker or breakers match their respective compartments.
2. Read the breaker summary sheet, the front view drawings, breaker nameplate, and the identification card on the breaker shipping carton.
3. To match the breaker to its proper compartment, refer to the breaker location list on the front view drawing. Find the proper breaker by the identification card on the breaker carton, or the mark number on the breaker nameplate. All identical breakers have the same mark numbers.
4. For retrofills replacing AK25 breakers, if applicable, the neutral disconnect assembly block and bracket within the compartment must be removed. Removing this item should be done only after the breaker, having been removed from the compartment, has been de-energized.



Clean and Grease Breaker

1. Before installing or operating a breaker, refer to the EntelliGuard G Breaker DEH-41304 instruction manual for pre-operation inspecting and testing.
2. Check thoroughly for any damaged or loose parts and for any dirt or foreign matter which may be on the breaker.
3. Clean those areas if necessary with a clean, lint-free rag and isopropyl alcohol or acetone.
4. Be sure to apply a thin film of electrical grease Mobilgrease 28 (D50HD38) to the primary disconnect fingers for better electrical connections on the breaker. GE Part # 193A1751P1 is a 1 oz. tube of this grease.

Customize Retrofill Secondary Wiring

| | |
|---|---|
|  | <p>WIRING</p> <ul style="list-style-type: none">• Before installing the breaker, the secondary disconnects must be wired to the EntelliGuard Breaker.• Wires with wire markers are provided on the retrofill. Make sure that the switchgear wiring connection points match up with the original wiring of the cubicle. This ensures that all wiring connections are properly made.• Wrong connections will cause the breaker to malfunction. |
|---|---|

Modify AKD-5 Switchgear Compartment

| | |
|---|--|
|  | <ul style="list-style-type: none">• It must be ensured that the supply power to the compartment is turned off/ compartment is de-energized for all the incoming and outgoing circuits of the LVS prior to any work being conducted on it.• During the installation and related work on the equipment, it must be ensured that the operator is using the prescribed PPE for the specified tasks. |
|  | |
| <ul style="list-style-type: none">• Ensure only qualified personnel install, operate, service, and maintain all electrical equipment. | |

Turn OFF/ OPEN the Legacy Circuit Breaker

1. Before modifying the switchgear compartment, de-energize/switch off the breaker. If the circuit breaker is ON and the springs are charged, to turn it off, press the OPEN button on the circuit breaker fascia; and ensure that the circuit breaker contacts are open. Discharge the closing spring before removing the breaker from the switchgear.

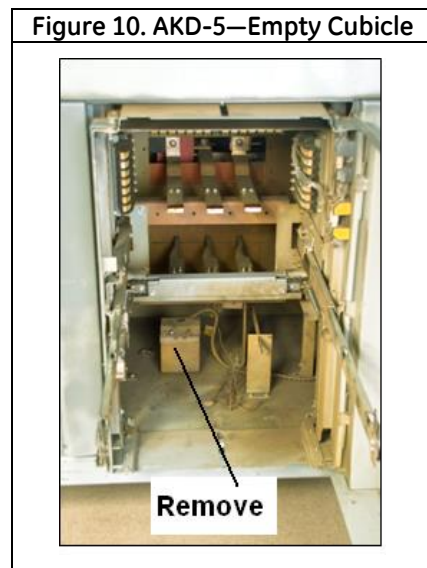
Rack Out Legacy Breaker

1. To rack-out legacy (old or original) breaker from the compartment, refer to your legacy-breaker's manual on how to remove the existing breaker.

Empty Compartment—Legacy Breaker Removed

The following examples show a legacy breaker removed from the enclosure or compartment ([Figure 10](#)).

Figure 10. AKD-5—Empty Cubicle



Check, Clean, Grease Compartment

1. Inspect the compartment for damage, rework.
2. Check cabinet for suitability of retrofit.
3. Having fully de-energized primary and control power, check each breaker compartment for bolted joints in the primary disconnect bars. Where such joints exist, check the bolts for tightness.
4. Inside the compartment, check the contact areas on each primary disconnect bar or cluster of fingers for foreign matter that may have accumulated. Clean those areas if necessary with a clean, lint-free rag and isopropyl alcohol or acetone.
5. Be sure to apply a thin film of electrical grease Mobilgrease 28 (D50HD38) to the contact areas for better electrical connections inside the compartment.
6. After removing the original AK breaker from the compartment, install the AKD-5 retrofit cassette. (Note: If compartment has a position switch and a position switch actuator will be added to the cassette, see Install Position Switch Actuator below.
7. Locate and replace Kirk key slide return spring on left side of compartment. Supplied with the cassette assembly as a retrofit kit. Inspect the Kirk key slide mechanism, grease with Mobilgrease 28 (D50HD38) if required.
8. Install the cap, label and ¼-20 set screw to disable old racking mechanism. Also assemble Kirk key side bracket, label and (2) ¼-20 Thread forming screws, see figure 10A & 10B. Supplied with the cassette assembly as a retrofit kit.

Figure 10A / 10B. AK-50 & AKT-50 – Retrofill Kits



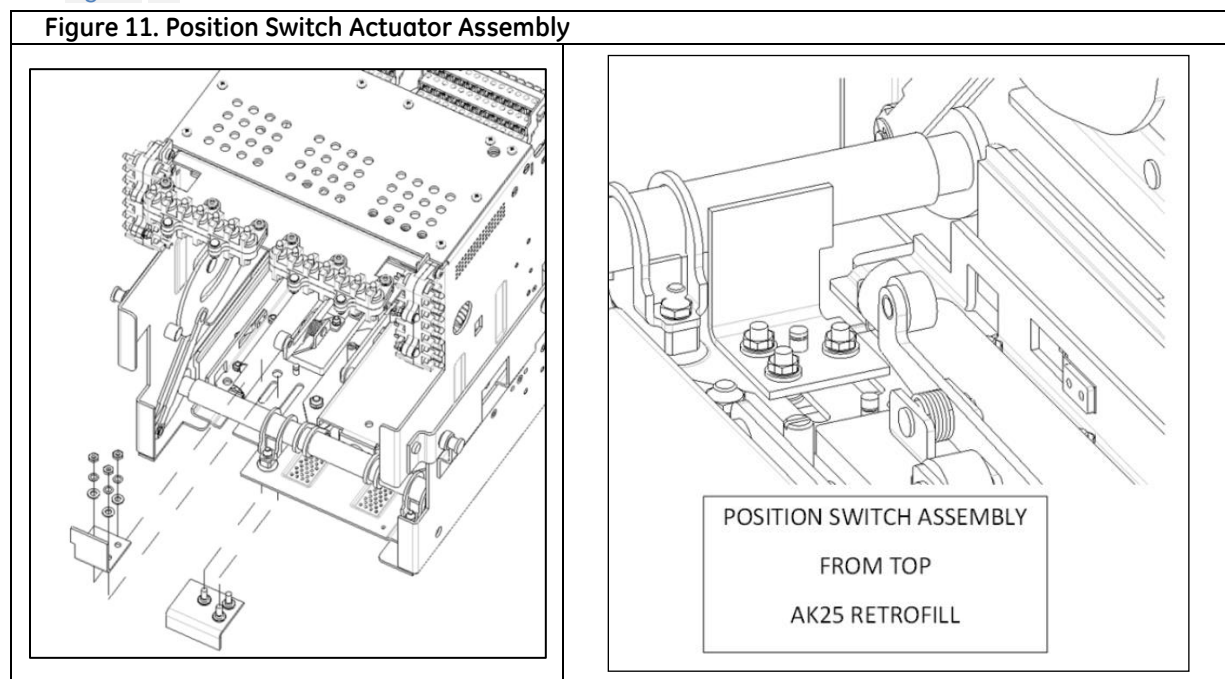
Install Position Switch Actuator—AK25 Breaker

Installing the position switch actuator needs to be done before the cassette is racked into the compartment. Steps of installation of the position switch actuator are as follows.

1. Place the retrofit EntelliGuard ACB cassette assembly for AK25 on an elevated surface, such as a table, mounting the position switch actuator assembly on to the base plate.

Sufficient space should be available at the bottom of the cassette and the mounting table so as to provide easy access for inserting the 3-pin bracket from the bottom.

2. Unpack the position switch actuator assembly and mount it as shown in the exploded view (Figure 11).



3. Insert the 3-pin bracket from the bottom of the base of the cassette assembly such that the 2 pins are within the longer slot and the single pin goes inside the smaller slot of the plate.

4. Place the L-bracket from the top of the cassette assembly such that the pins from the bottom 3 pin plate get inserted into the top plate.
5. Secure the connecting by fastening the nuts provided in the actuator kit along with the washers.
6. Mount the extension springs between the groove of the pin on this actuator assembly and the fixed pin provided on the cassette base plate.

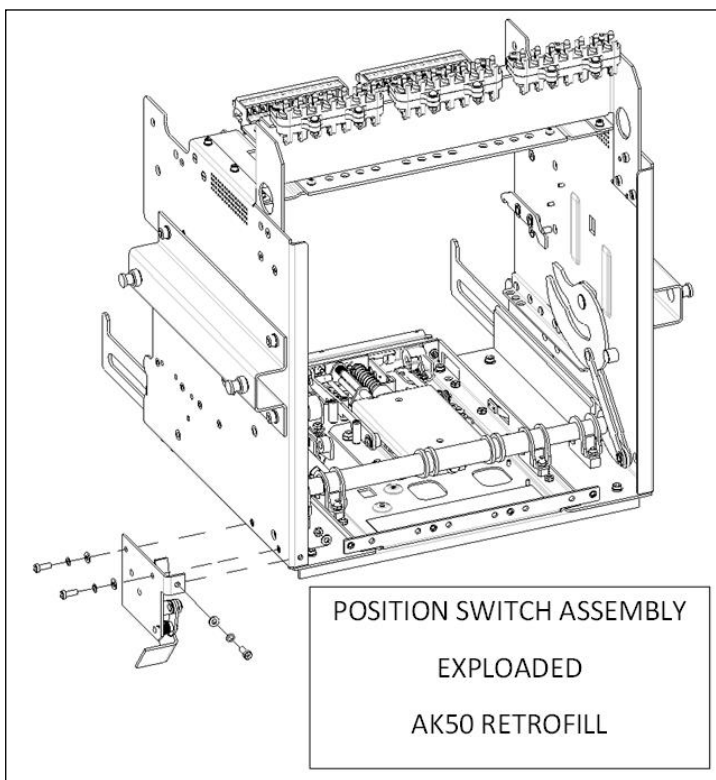
Note that the position switch actuator on the cassette is now installed and ready for use once the breaker is being racked into the compartment.

7. Mount the cassette assembly on the rails of the AK25 cabinet in the AKD-5 and rack the cassette into the compartment of the AKD-5 LVS.

Note: During racking of the EntelliGuard R breaker into the cassette, the position switch in the compartment changes state as the breaker reaches the CONNECTED position in the LVS (Low Voltage Switchgear).

Install Position Switch Actuator—AK50 Breaker

Figure 12. AKD-5—AK50, Actuator for Position Switch Assembly (Exploded View)



The position switch actuator assembly for the AK50 should be mounted on the bottom right side of the cassette assembly. The actuator assembly consists of a linkage system that interfaces with the racking shaft assembly at one end and the position switch actuator arm on the other. Completing the racking in of the EntelliGuard breaker into the cassette corresponds to the end of stroke of the position switch system in the compartment for AK50 in AKD-5 LVS.

Figure 12 shows the AK50 position switch actuator assembly in an exploded view. The position switch actuator of the AK50 is a field-fit type of assembly and is assembled on the retrofill cassette before insertion of the cassette into the compartment of the AKD-5.

8. Make sure that the cassette is in the disconnected state.

This can be verified by checking the racking position status on the window located at the Left side window on the frame of the AK50 Retrofill cassette. The position switch actuator kit of the AKD5—

AK50 retrofits must be installed on the rear side, right-side sheet of the AK50 retrofill cassette.

9. Place the cassette on a work table.

The cassette should be positioned such that there is enough overhang of its side to insert the position switch actuator assembly in the bottom of the cassette. Alternately, the installation can also be done by placing the cassette assembly on the telescopic rails of the AKD5 compartment, being retrofitted.

10. To install the position switch actuator, slide the assembly up from the bottom of the cassette. When inserted, flip the position switch.
11. Line up the holes on the cassette side sheet with the holes provided on the actuator assembly.
12. Fasten the 3 M6 bolts and 6mm washers provided with the actuator assembly to the three holes on the cassette side sheet. Two holes are placed on the side and one hole on the rear of the cassette assembly.

The position switch actuator on the cassette is now installed and ready to be activated as soon as the breaker is racked into the compartment.

13. Mount the cassette assembly on the rails of the AKD-5 LVS and rack the cassette into the compartment.

Note: As the EntelliGuard R breaker is racked into the cassette, and the position indicator window reads “connected” the retrofill Position Switch actuator should activate the compartment mounted position switch in the AKD-5 LVS.

Racking-Lock Bracket—Initial Tasks (AK-25 Cabinet Only)



- It must be ensured that the supply power to the compartment is turned off/ compartment is de-energized for all the incoming and outgoing circuits of the LVS prior to any work being conducted on it.
 - During the installation and related work on the equipment, it must be ensured that the operator is using the prescribed PPE for the specified tasks.
- Ensure only qualified personnel install, operate, service, and maintain all electrical equipment.

1. Remove existing indicator assembly system from AKD-5 cabinet rails ([Figure 13](#)).
2. Clean the area of the moving frame assembly of any dirt or debris.
3. Unpack the racking lock kit for the AKD-5.
4. Use this bracket as a template for drilling the holes in the frame ([Figure 14](#)).

Figure 13. Legacy Indicator Assembly

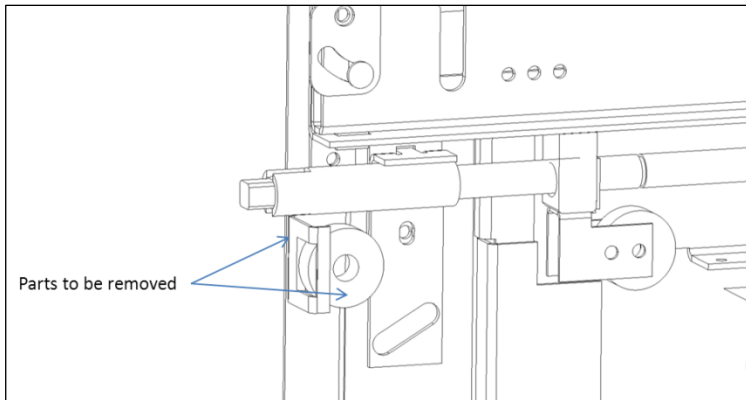
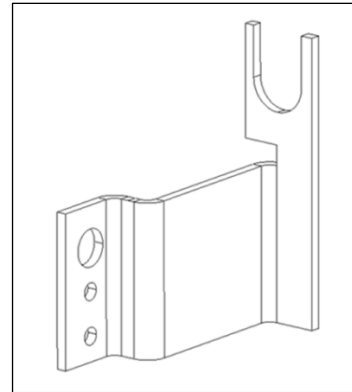


Figure 14. Bracket Template for Drilling Holes



5. Slide the bracket (*Figure 14*) up to its fixing location as shown in the illustration (*Figure 15*).
6. Line up the guiding holes (*Figure 16*).

Figure 15. Slide Bracket Up

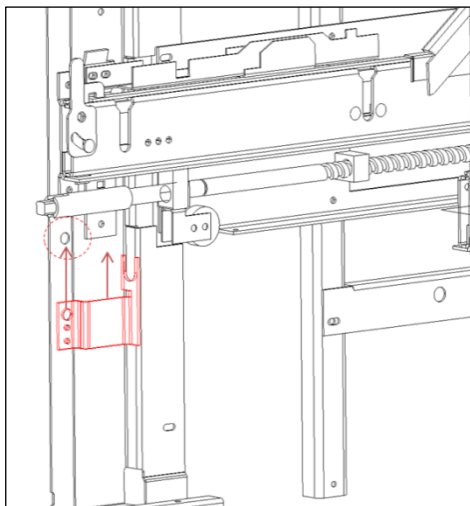
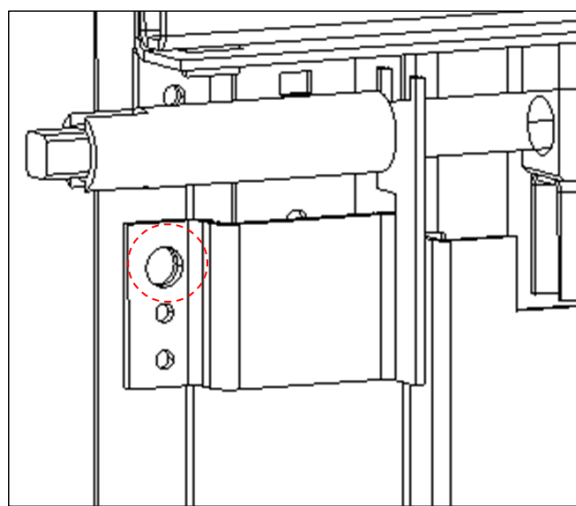


Figure 16. Line Up Holes



7. Mark the bottom two holes using the bracket as a template.
8. Take the bracket out and drill 0.18-in diameter pilot holes in the frame.

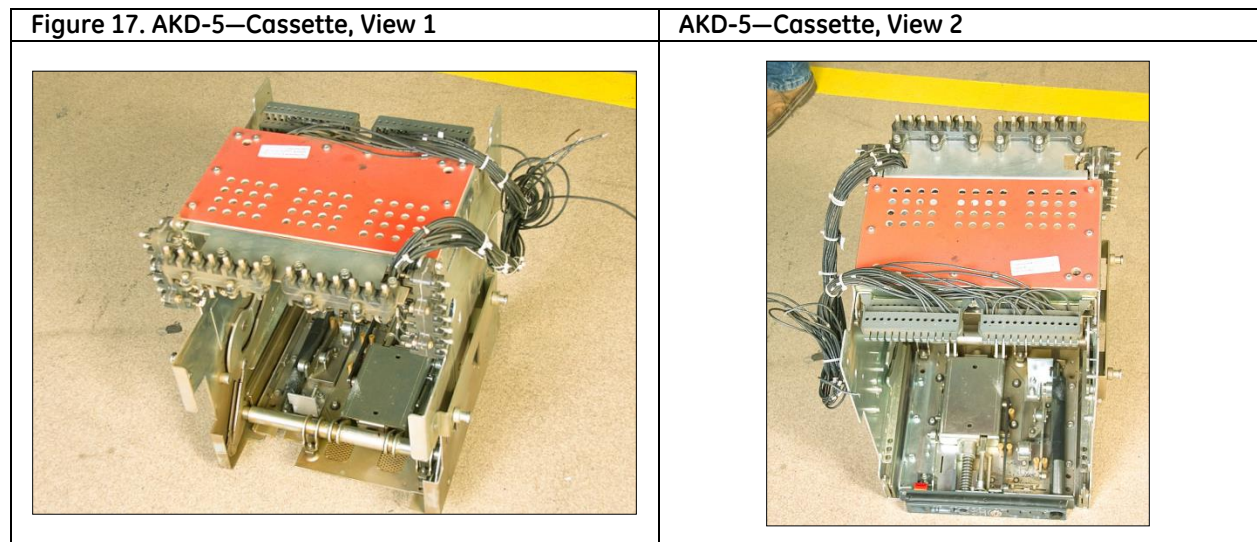
Install Cassette (Landed Wires)



- Ensure only qualified personnel install, operate, service, and maintain all electrical equipment.

- It must be ensured that the supply power to the compartment is turned off/ compartment is de-energized for all the incoming and outgoing circuits of the LVS prior to any work being conducted on it.
- During the installation and related work on the equipment, it must be ensured that the operator is using the prescribed PPE for the specified tasks.

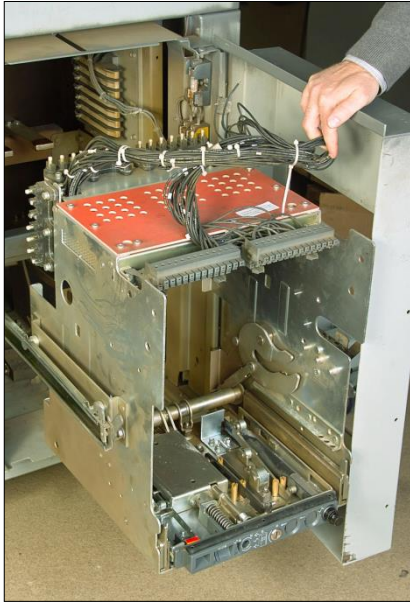
The photo in [View 1](#) of [Figure 17](#) shows the rear view of the wires landed on the AKD-5 cassette; [View 2](#) shows the front view of the AKD-5 cassette, ready for installation.



1. Install the pre-wired cassette in the enclosure as demonstrated in the photos, below.
2. Place the cassette on the rails for racking into the switchgear cabinet ([Figure 18](#)).
3. Slide the retrofit cassette into the compartment till dead-stop.
4. Lock the rails of the legacy compartment to ensure inner and outer rail movement.
5. Use legacy (old or original) AKR racking handle for inserting the retrofit cassette.
6. Fix legacy (old or original) racker-lock on the compartment side frame to block slide back of sleeve.

The following photos show how the cassette is racked in and secured ([Figure 19](#)), rails extended ([Figure 20](#)), left side view; and ([Figure 21](#)), racking in.

Figure 18. AKD-5—Cassette To Be Racked In, View 1



AKD-5—Cassette To Be Racked In, View 2

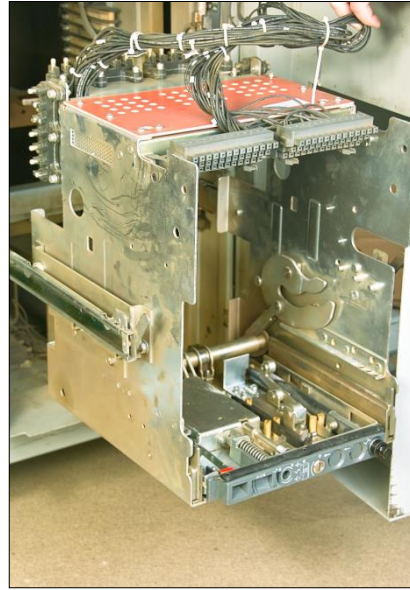


Figure 19. AKD-5—Cassette or Substructure, Rails Extended

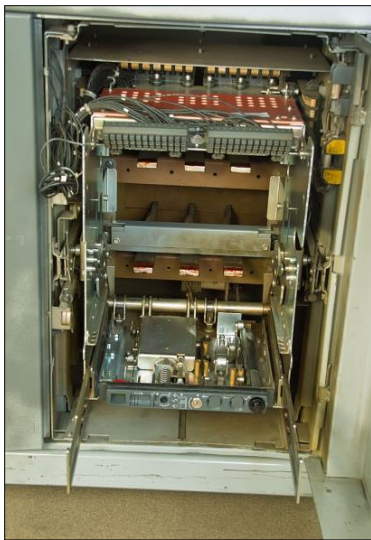
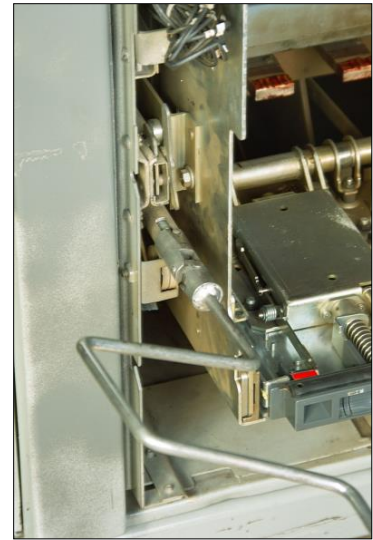


Figure 20. AKD-5—Cassette or Substructure, Left Side Details



Figure 21. AKD-5—Cassette or Substructure, Racking and Removing Tool, View 1



The next two figures ([Figure 22](#) and [Figure 23](#)) display the complete racking in of the pre-wired cassette.

Figure 22. AKD-5—Cassette or Substructure, Racking and Removing Tool – (AK-25 Cabinet Only)

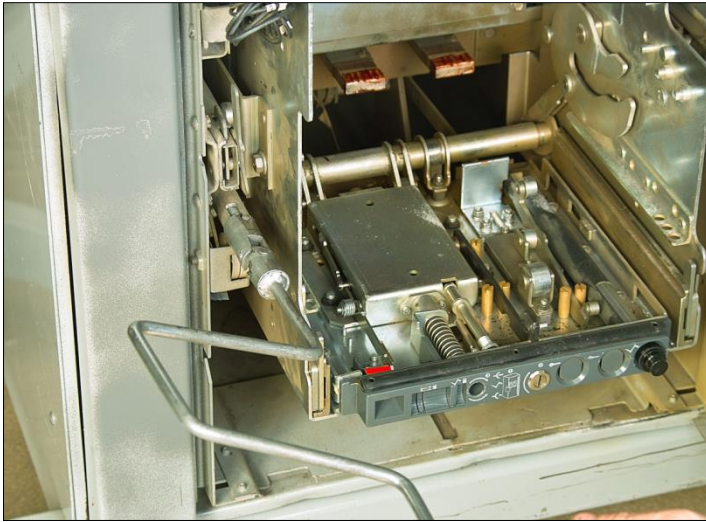
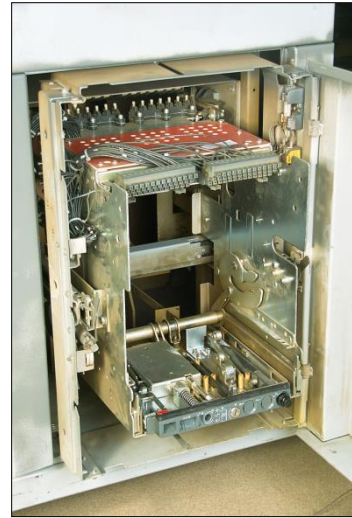
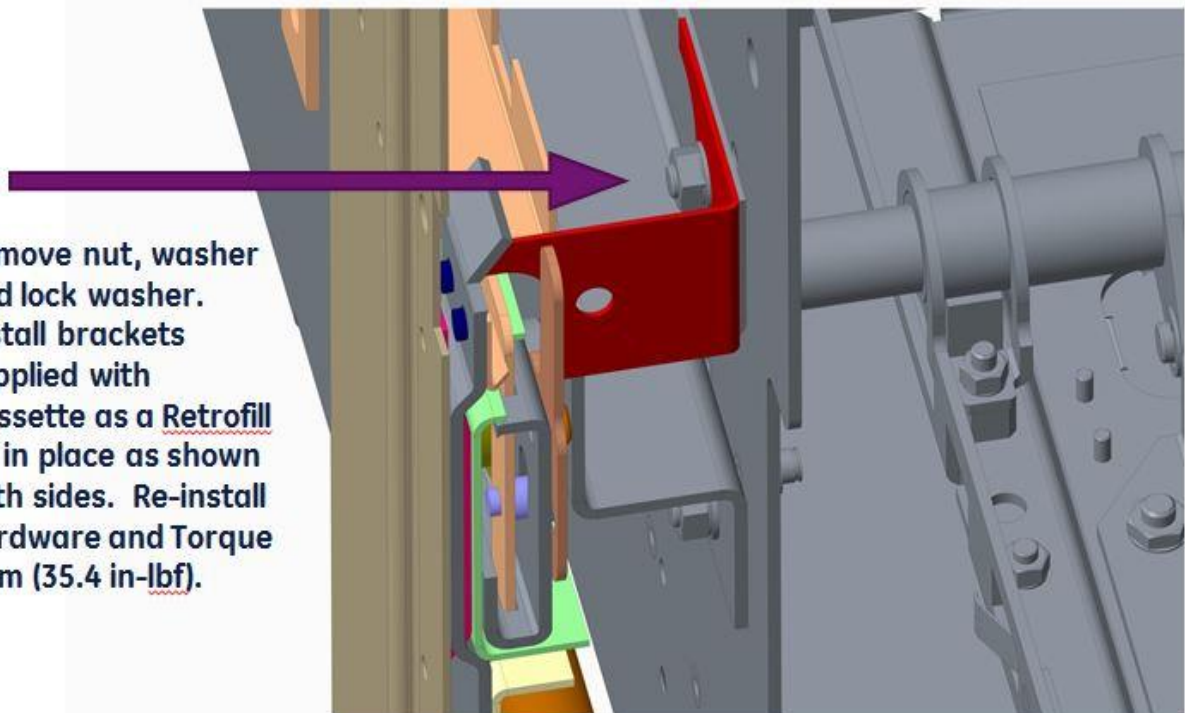


Figure 23. AKD-5—Cassette or Substructure, Now Racked In



Install Cassette Rail Lever Lockout Brackets- AK/AKT-50 Comp't Only

Remove nut, washer and lock washer. Install brackets supplied with Cassette as a Retrofill kit in place as shown both sides. Re-install hardware and Torque 4Nm (35.4 in-lbf).

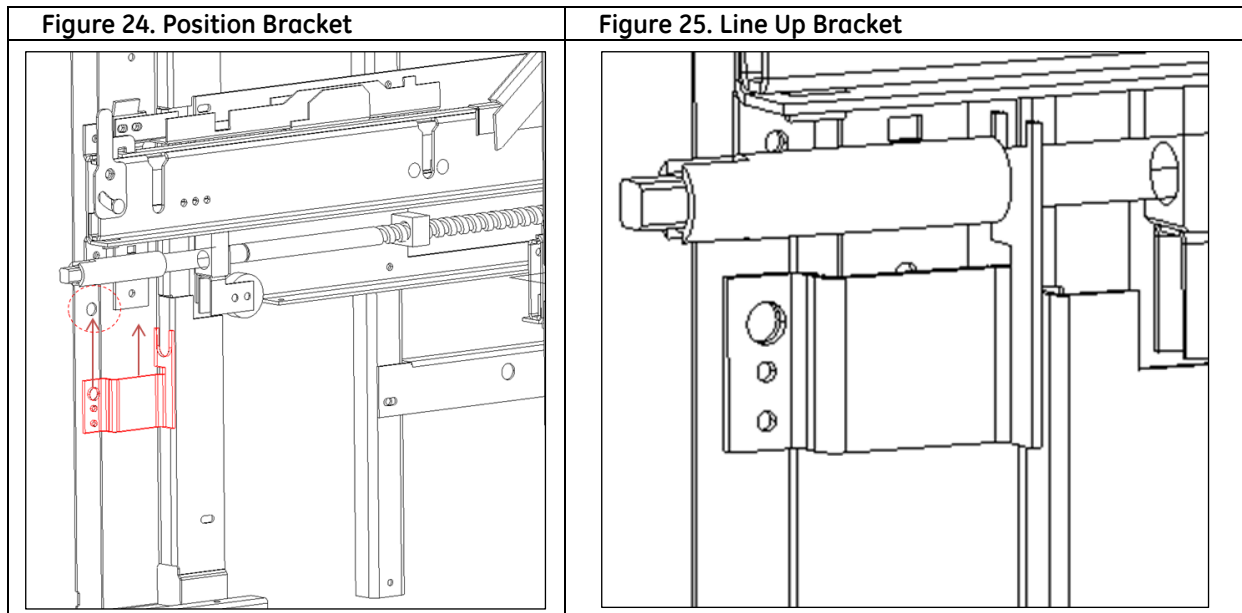


Install Lock Bracket (AK-25 Cabinet Only)



- It must be ensured that the supply power to the compartment is turned off/ compartment is de-energized for all the incoming and outgoing circuits of the LVS prior to any work being conducted on it.
 - During the installation and related work on the equipment, it must be ensured that the operator is using the prescribed PPE for the specified tasks.
- **Ensure only qualified personnel install, operate, service, and maintain all electrical equipment.**

1. Check that the retrofitted EntelliGuard cassette has been completely racked into the cabinet.
2. Slide the bracket back into position as shown in the image below ([Figure 24](#)) and line up the holes previously drilled with the holes on the locking bracket ([Figure 25](#)).



3. Secure the bracket to the side frame by using the two self-tapping screws provided with the kit ([Figure 26](#) and [Figure 27](#)).

Tools required: Spanner, 0.2-inch drill bit, hand drill

Figure 26. Installed Bracket (View 1)

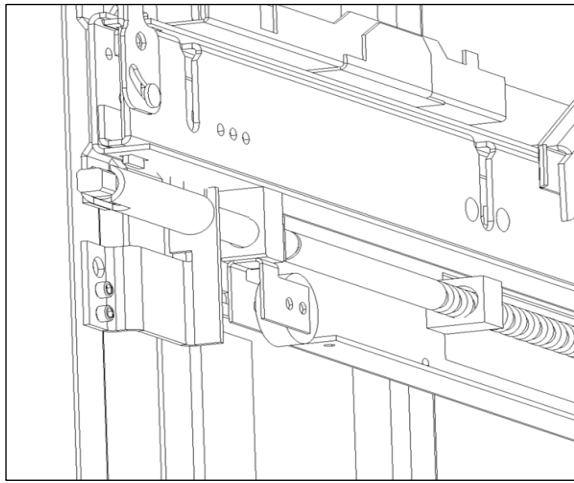
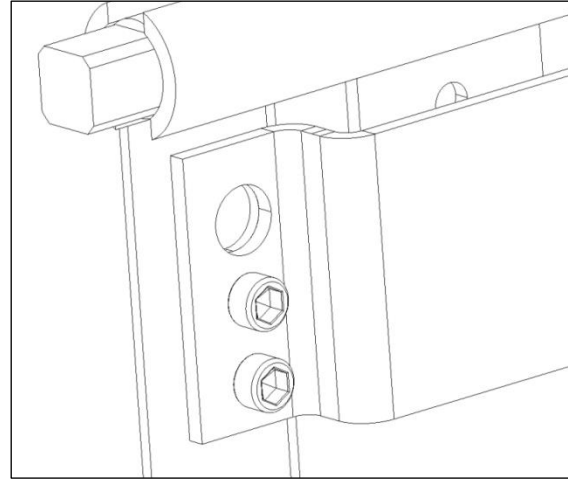


Figure 27. Installed Bracket (View 2)



Install AKD-5 Retrofill Breaker



- It must be ensured that the supply power to the compartment is turned off/ compartment is de-energized for all the incoming and outgoing circuits of the LVS prior to any work being conducted on it.
 - During the installation and related work on the equipment, it must be ensured that the operator is using the prescribed PPE for the specified tasks.
- Ensure only qualified personnel install, operate, service, and maintain all electrical equipment.

1. Before inserting the retrofit breaker into the cabinet, make sure that the breaker is switched off. If the spring indicator shows that it is charged, the assembly needs to be discharged, by first switching on the breaker and then switching it off.
2. After racking in the cassette, get ready to install the AKD-5 breaker assembly by pulling the lifting hooks up (lifting handles, eyes, or ears) from their slots. Use a tool or screwdriver to keep them up, if necessary ([Figure 28](#)).

Figure 28. AKD-5—Breaker Lifting Holes

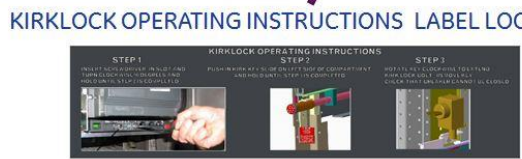


3. Use an appropriate lifting device to install the breaker. See ([Figure 28](#)).
4. Make sure that the lifting hooks are secured and locked in place on the breaker.
5. Put the breaker in front of the unit where it is to be installed, leaving enough clearance to swing the compartment door open to access the enclosure. ([Figure 29](#)).
6. When the breaker is lined up with the compartment, raise the breaker only slightly higher than the compartment floor, keeping it at a slight angle.
7. Open the compartment door, to install the breaker in the cassette, ([Figure 30](#)).

Figure 29. Cabinet with Compartment Door Closed

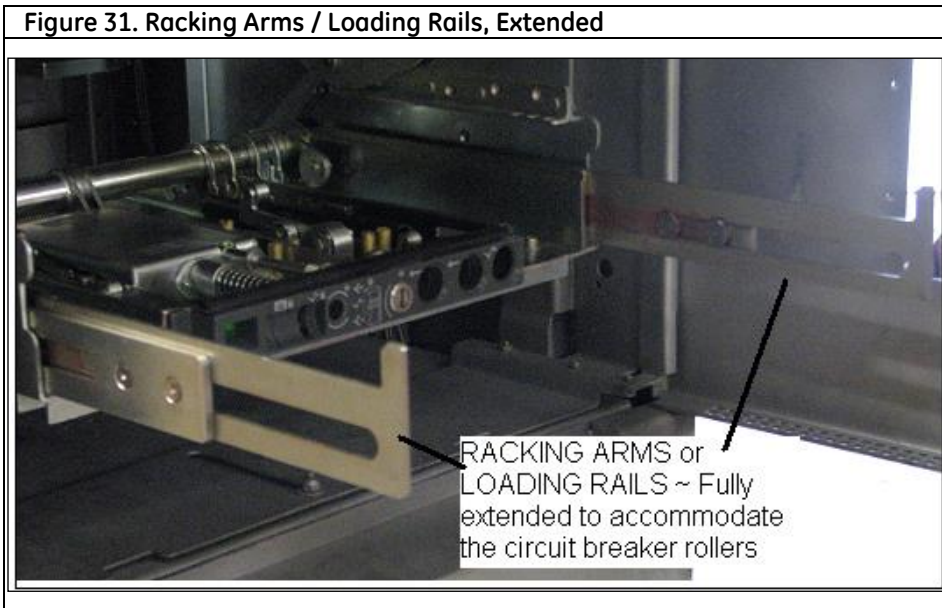


Figure 30. Cabinet with Compartment Door Open



8. Check that the cassette is free from obstruction. [Figure 30](#) displays the racking assembly, supporting the new retrofit breaker and Kirk Lock Information Label supplied with AK-50 & AKT-50 Cassettes.

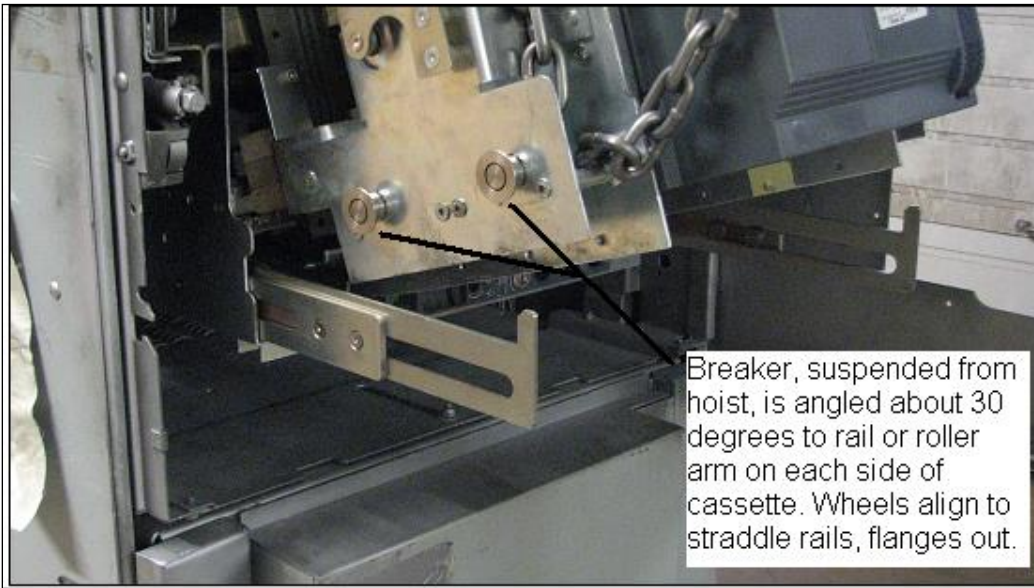
9. If the racking panel of the cassette is padlocked, it may need to be opened to access the racking mechanism.
10. Verify that the cassette position indicator shows DISCONNECTED and the racking handle is disengaged.
11. Ensure that the cassette racking cams on both side walls of the cassette are in the completely racked-out position.
12. Pull out the two cassette LOADING RAILS to their full extent, horizontal to the ground ([Figure 31](#)).



13. Lower the circuit breaker gradually, at an angle, so that the rollers drop over the rails. Make sure that the grooves in all rollers straddle the rails as shown in [Figure 32](#).

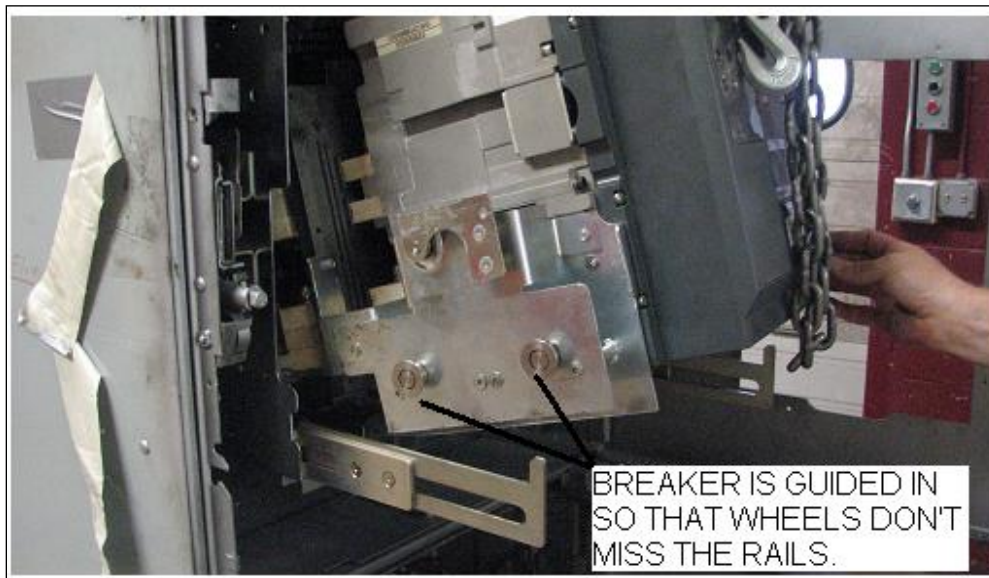
This might need a two-man effort: one to carefully and slowly lower the suspended breaker and the other to guide the breaker into the cassette enclosure. See [Figure 32](#).

Figure 32. Inserting Breaker into Cassette, Wheels Lined Up with Roller Arms



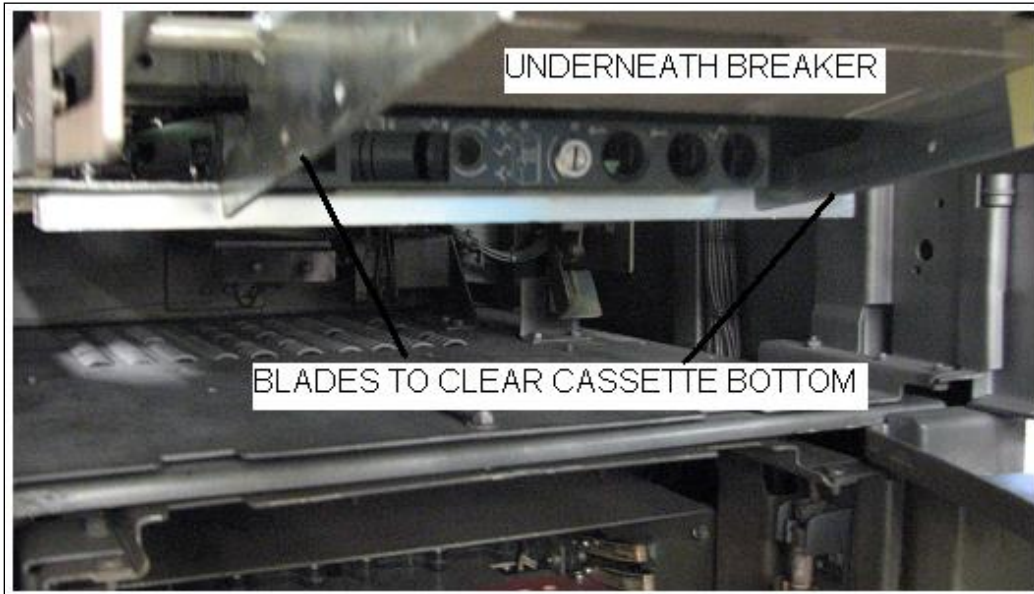
14. Keep the breaker steady. Continue to guide the breaker, while checking both sides and underneath the assembly, so that both sets of wheels can be lowered easily on the cassette rails ([Figure 33](#)). Check that the grooves in all rollers straddle the rails.

Figure 33. Keeping Breaker Steady



15. Peer underneath the breaker, as you maneuver it in, to make sure that the dual blades clear the bottom of cassette. [See Figure 34](#).

Figure 34. View of Underside of Breaker



16. As soon as the breaker is resting on the rails [Figure 35](#), unhook the lift from the ears of the circuit breaker and move the hoisting apparatus out of the way.

Figure 35. Breaker Positioned on Rails



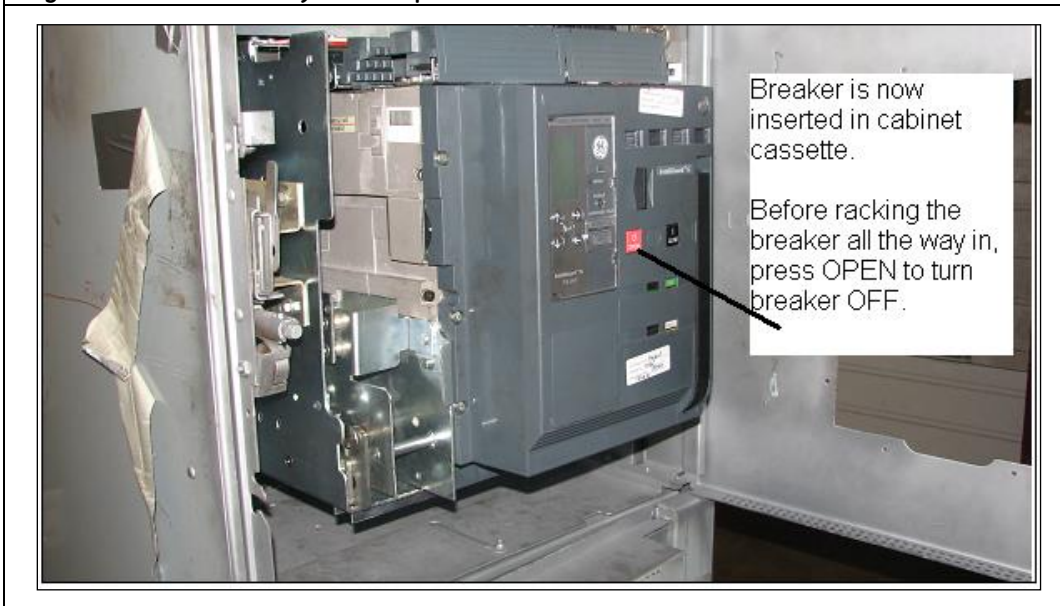
17. Using the hand grips on either side, move or push the circuit breaker into the cassette until it reaches a positive stop (the rollers on circuit breaker are engaged with the racking cams of the cassette on both sides).

The circuit breaker is now in the DISCONNECTED position ([Figure 36](#)).

18. Push back both the extended rails of the cassette to the stowed position.

19. If the circuit breaker is ON and the springs are charged, to turn the breaker off, press the OPEN button on the circuit breaker fascia and ensure the circuit breaker contacts are open.

Figure 36. Breaker Ready for Complete Installation



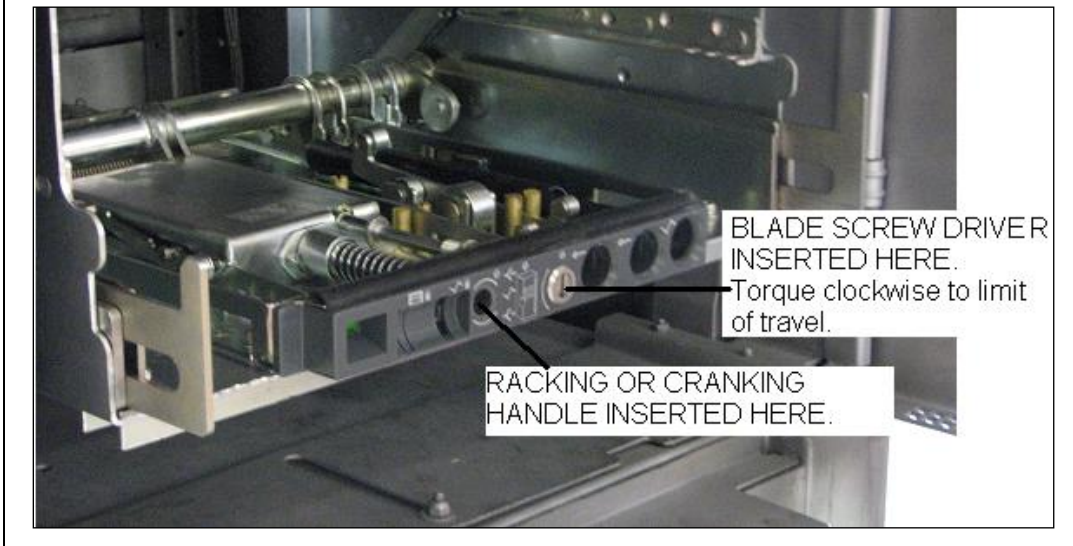
20. Remove the racking tool ([Figure 37](#)) from the storage location on the cassette right front panel.
21. Extend the racking tool to create a cranking device.

Figure 37. Racking Tool



22. [Figure 38](#) shows the racking tool extended.

Figure 38. Racking Assembly Inside Switchgear Compartment (w/no breaker)



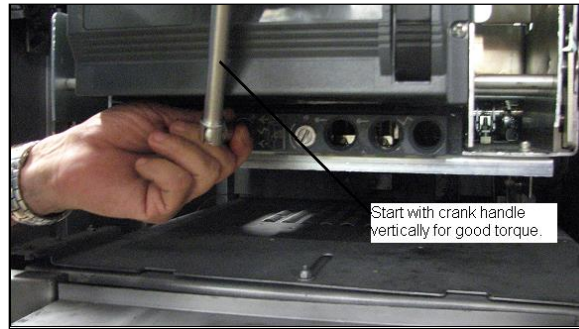
23. Insert a screwdriver in the slot or rack-out lock, and turn it clockwise 90° so that the racking handle shutter opens and insert the racking tool. (It resembles a vehicle ignition lock. See [Figure 39](#).)

Figure 39. Shutter



24. Insert the tool so it engages the racking mechanism inside the hole.
25. Then, crank clockwise so that the breaker starts to move in, slowly sliding forward. Rotating clockwise ~ 37 turns racks the circuit breaker all the way into the cassette.

Figure 40. Crank or Racking Handle Inserted



26. As the breaker approaches the TEST position, check the alignment of the fixed and moving parts of the secondary disconnect contacts. (If a motor-spring charge or under-voltage release is installed, the device may operate when approaching the TEST position)
27. Continue rotating the racking handle clockwise until the position indicator first shows TEST, then CONNECTED.

When approaching the CONNECTED position, effort to turn the racking handle increases as the primary finger clusters engage with the AKD-5 bus stabs..

28. Keep cranking until reaching a positive stop. Full travel is about 37 turns and about 3 turns after the indicator first shows Connected.
At this point, the fingers at the back of the circuit breaker should be properly engaged on the bus stabs of the AKD-5 switchgear.
29. Using a light and mirror try to make an observation of the primary disconnect fingers to be sure they are making good contact on the flat portions of the switchgear bus stabs.
30. Remove and store the racking handle in its storage location.
31. Note that the circuit breaker is now ready for normal operation.

AK/AKT-50 – Kirk Key Interlock

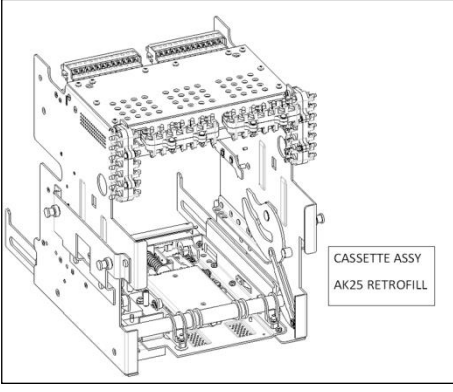
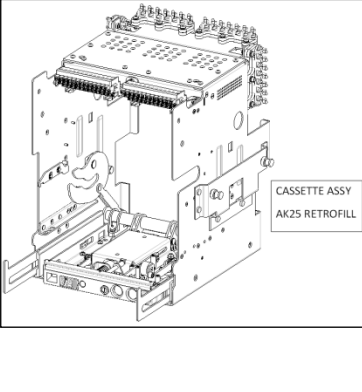
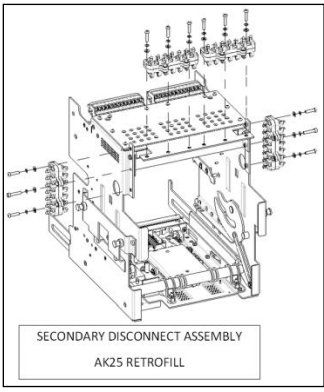
The EntelliGuard R retrofill circuit breakers provided as replacements for WavePro 1600A-2000A frame circuit breakers have a trip interlock feature which will function using the AK/AKT-50 compartment mounted Key Interlock. A label is provided with full instructions on how to operate the Legacy Key Interlock. It is suggested to apply the label on the inside of the compartment door ([Figure 30](#)). Following is a brief summary of how the Key Interlock system is operated.

To activate the key interlock:

- 1) OPEN the breaker.
- 2) Rotate the screw on the lower front panel of the cassette which normally allows access to the racking screw. This will hold the breaker trip free.
- 3) While the screw is held rotated Clockwise, the Key Interlock slide in the switchgear is pushed inward, elevating a pin on the left side of the breaker.
- 4) Turn the key to the key removal position, extending the bolt and lock the breaker in the OPEN position.

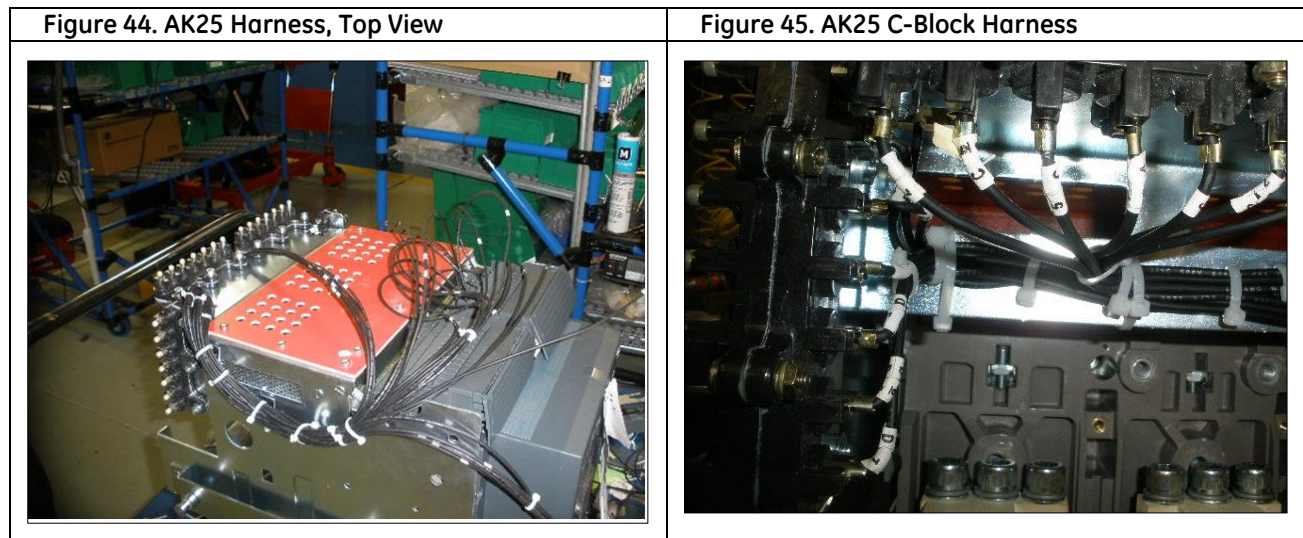
Secondary Disconnects, Bullets

The circuit breaker secondary disconnects are already located on, or wired to, the breaker's cassette. The landing of the wiring on the EntelliGuard R breaker cassette is done in the field. Up to 78 points are available so that all breaker accessories can be wired to dedicated disconnect-points in the cubicle. Each breaker wire is identified with a unique label. The wireframes in [Figure 41](#) and [Figure 42](#) depict the secondary disconnect assemblies for the AKD-5 AK25/AK50. [Figure 43](#) shows the exploded view of four blocks of secondary disconnects. The cassette is a separate assembly from the retrofit breaker; first, the cassette is to be wired and then installed in the switchgear, the followed by the breaker being racked into the cassette.

| Figure 41. AK25 Retrofit Breaker Cassette Assembly (Rear View) | Figure 42. AK25 Retrofit Breaker Cassette Assembly (Front View) | Figure 43. AK25 Retrofit Breaker Cassette Assembly (Exploded View) |
|--|---|--|
|  <p>CASSETTE ASSY AK25 RETROFILL</p> |  <p>CASSETTE ASSY AK25 RETROFILL</p> |  <p>SECONDARY DISCONNECT ASSEMBLY AK25 RETROFILL</p> |
| P/N 386A110G2 | Retrofit Sec Disc Assy AKR | AKD5 |

The wiring harness for the secondary disconnects, located on the AKD-5 retrofill cassette, has 21 wire connections (grouped in three blocks (A, B, C) for AK50 or 28 wire connections (grouped in 4 blocks (A, B, C, D)) for AK25, with seven wire connections for each block). Each wire is clearly labeled, or identified, with wire markers or tags. Each wire on the 21-wire harness is connected to a bullet. Each bullet, when the cassette is racked in, engages with its respective points in the switchgear. The wires for Block A are identified as A1, A2,...A7. Block B wiring is likewise labeled as B1, B2, B3,....B7. Block C contains C1, C2,....C7. The end, opposite of the bullets, maps or connects to the retrofill EntelliGuard R Cassette 78-point, secondary-disconnect. For example, if bullets A1 and A4 are reserved for the motor, they connect to points A1 and A2 on the cassette's 78-point, secondary-disconnect for a motor. Each breaker needs to be landed in the field based on the specifics breakers wiring diagram and modifications made in the field.

[Figure 44](#) is a photo of the AKD-5—AK25 harness and [Figure 45](#) is an AKD-5—AK25 C-block photo.



Wiring Diagram and Block Info (AK25)

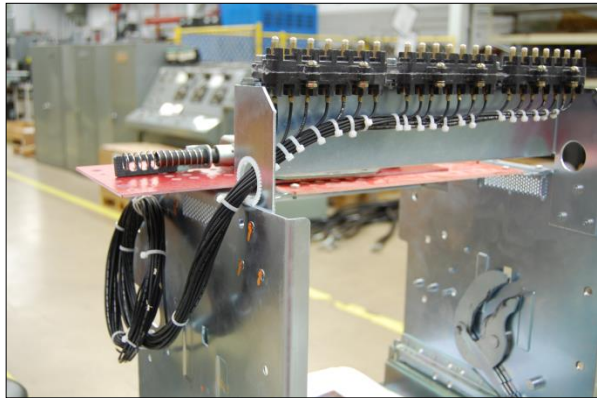
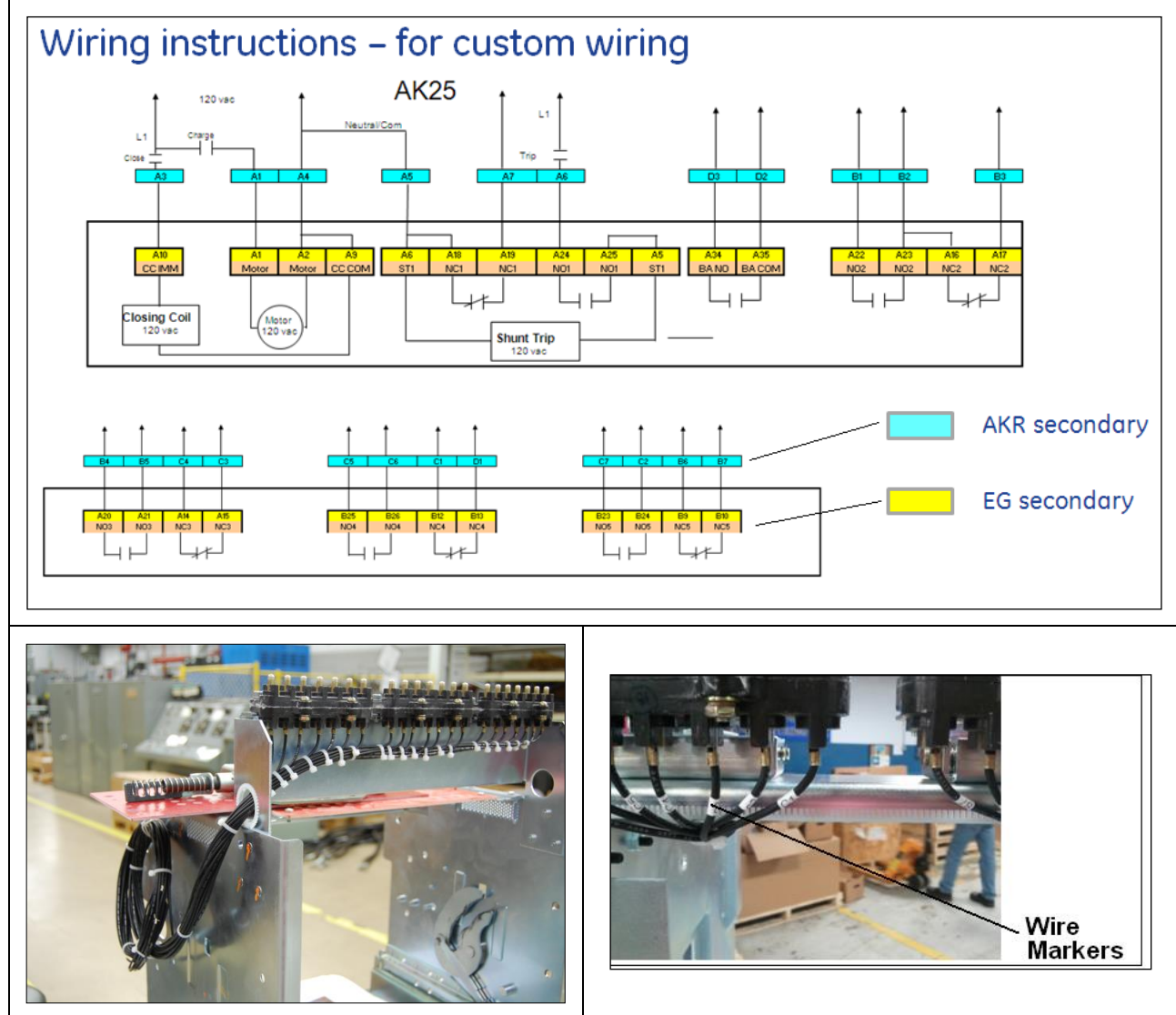
Additional wire markers, cable ties, spade terminals, and sticky pads are provided. Refer to the AK wiring scheme (Figure 46) and land the wires on EG-fixed secondary-disconnects. Wires are cut to size and crimped with the terminal lugs, and provided with wire markers. Harness by cable ties is completed and overhanging wires are checked. Similar to the AKD-5 AK25, the AKD-5 AK50 breaker roll-in replacement uses a similar wire harness and is mounted on the cassette. For further information on blocks and secondary-disconnects see **Error! Reference source not found.** [on PageError! Bookmark not defined.](#)

1. Get these tools needed for the task: Philips head screw driver, wire strippers, wire crimps, tie-wraps.
2. Identify each bullet using the legacy wiring diagram and any changes that were made to the legacy compartment. Four-wire ground fault CTs are wired through a dedicated neutral disconnect vs. the secondary bullets.

- With each bullet identified, land the non-bullet side to the corresponding feature on the EntelliGuard R's 78-point secondary disconnects. (See [Error! Reference source not found.](#) on [Page Error! Bookmark not defined.](#))

If a wire is too long, cut the wire, crimp a new connector, and install the provided wire markers on the bullets. Refer to [Error! Reference source not found.](#), [Page Error! Bookmark not defined.](#)

Figure 46. Example Wiring Diagram for AK25 Secondary Disconnects and Photo Example



Below are tables ([Table 7](#) and [Table 8](#)) featuring the two 39-blocks (A and B). They make up the 78-point secondary-disconnects.

Table 7. EntelliGuard G 39-Point Secondary A-Block.

| | A1 | A2 | A3 | A4 | A5 | A6 | A7 | A8 | A9 | A10 | A11 | A12 | A13 |
|------------------|-------------------|------------------|-------------------|-------------------|---------|---------|-------|-------|--------|--------|--------|-------------|-------------|
| | Motor | Motor | Spr NO/ RTC NO | Spr NO/ RTC NO | ST1 | ST1 | UV1 | UV1 | CC COM | CC IMM | CC CMD | ST2/ UV2 | ST2/ UV2 |
| Max. Current (I) | 14.8 A | 14.8 A | 10 A | 10 A | 1.9 A | 1.9 A | 1.9 A | 1.9 A | 1.9 A | 1.9 A | 1.9 A | 1.9 A | 1.9 A |
| Max. Voltage (V) | 440 V | 440 V | 240 V | 240 V | 440 V | 440 V | 440 V | 440 V | 440 V | 440 V | 440 V | 440 V | 440 V |
| | A14 | A15 | A16 | A17 | A18 | A19 | A20 | A21 | A22 | A23 | A24 | A25 | A26 |
| | NC3 | NC3 | NC2 | NC2 | NC1 | NC1 | NO3 | NO3 | NO2 | NO2 | NO1 | NO1 | - |
| Max. Current (I) | 15 A | 15 A | 15 A | 15 A | 15 A | 15 A | 15 A | 15 A | 15 A | 15 A | 1 A | 15 A | - |
| Max. Voltage (V) | 440 V | 440 V | 440 V | 440 V | 440 V | 440 V | 440 V | 440 V | 440 V | 440 V | 440 V | 440 V | - |
| | A27 | A28 | A29 | A30 | A31 | A32 | A33 | A34 | A35 | A36 | A37 | A38 | A39 |
| | O/P1a | O/P1b | O/P2a | O/P2b | 24 V+ | 24 V- | BA NC | BA NO | BA COM | N-RC- | N-RC+ | Eleg-CT | Eleg-CT |
| Max. Current (I) | 1 A | 1 A | 1 A | 1 A | <500 mA | <500 mA | 10 A | 10 A | 10 A | <50 mA | <50 mA | 5 A | 5 A |
| Max. Voltage (V) | 30 Vdc/ 25 Vac | 30 dc/ 25 Vac | 30 Vdc/ 25 Vac | 30 Vdc/ 25 Vac | 30 V | 30 V | 240 V | 240 V | 240 V | 480 mV | 480 mV | 2 V | 2 V |

Table 8. EntelliGuard G 39-Point Secondary B-Block.

| | B1 | B2 | B3 | B4 | B5 | B6 | B7 | B8 | B9 | B10 | B11 | B12 | B13 |
|------------------|-------------------|-------------------|-------------------|-----------------|-----------------|---------------------------|--------------------------------|--------|--------|----------------|--------|--------|--------|
| | INPUT1 | INPUT2 | I/P COM | ST1 NO/ NC8 | ST1 COM/ NC8 | UV1 NO/ NC7 | UV1 COM/ NC7 | NC6 | NC6 | NC5 | NC5 | NC4 | NC4 |
| Max. Current (I) | <50 mA | <50 mA | <50 mA | 10 A/15 A | 10 A/15 A | 10 A/15 A | 10 A/15 A | 15 A | 15 A | 15 A | 15 A | 15 A | 15 A |
| Max. Voltage (V) | 30 Vdc/ 25 Vac | 30 Vdc/ 25 Vac | 30 Vdc/ 25 Vac | 240 V/ 440 V | 240 V/ 440 V | 240 V/ 440 V | 240 V/ 440 V | 440 V | 440 V | 440 V | 440 V | 440 V | 440 V |
| | B14 | B15 | B16 | B17 | B18 | B19 | B20 | B21 | B22 | B23 | B24 | B25 | B26 |
| | RELT INPUT | COM | - | CC NO/ NO8 | CC COM/ NO8 | ST2 NO/ UV2 NO/ NO7 | ST2 COM/ UV2 COM/ NO7 | NO6 | NO6 | NO5 | NO5 | NO4 | NO4 |
| Max. Current (I) | <50 mA | <500 mA | - | 10 A/ 15 A | 10 A/ 15 A | 10 A/ 15 A | 10 A/ 15 A | 15 A | 15 A | 15 A | 15 A | 15 A | 15 A |
| Max. Voltage (V) | 5 V | 0.1V | - | 240 V/ 440 V | 240 V/ 440 V | 240 V/ 440 V | 240 V/ 440 V | 440 V | 440 V | 440 V | 440 V | 440 V | 440 V |
| | B27 | B28 | B29 | B30 | B31 | B32 | B33 | B34 | B35 | B36 | B37 | B38 | B39 |
| | ZSI out+ | ZSI out- | ZSI in+ | ZSI in- | ISO GND | 5V ISO | TX EN 1 | RX | TX | GND Volt-IN | Volt-A | Volt-B | Volt-C |
| Max. Current (I) | <50 mA | <50 mA | <50 mA | <50 mA | <500 mA | <500 mA | <50 mA | <50 mA | <50 mA | <500 mA | <50 mA | <50 mA | <50 mA |
| Max. Voltage (V) | 28 Vdc | 28 Vdc | 30 Vdc | 30 Vdc | 0.1V | 5 V | 5 V | 5 V | 5 V | 0.1V | 1.76 V | 1.76 V | 1.76 V |

AK25 Wiring Harness, B-Block (AK25/50)

Photo in [Figure 47](#) shows you the B-block harness and Figure 48 is a close-up photo of the harness. Figure 49 shows you the secondary bullets.

Figure 47. AK25 B-Block Harness

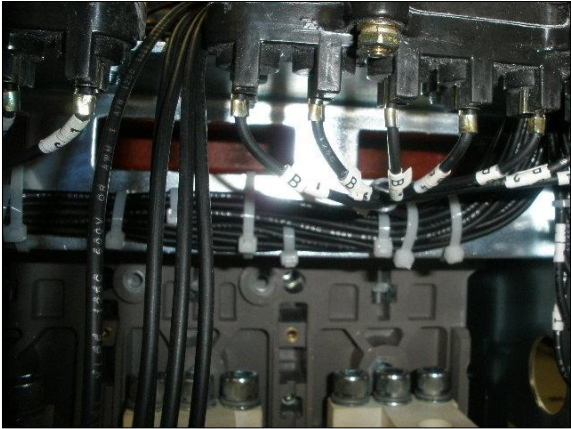


Figure 48. AK25 Wiring Harness, Close Up

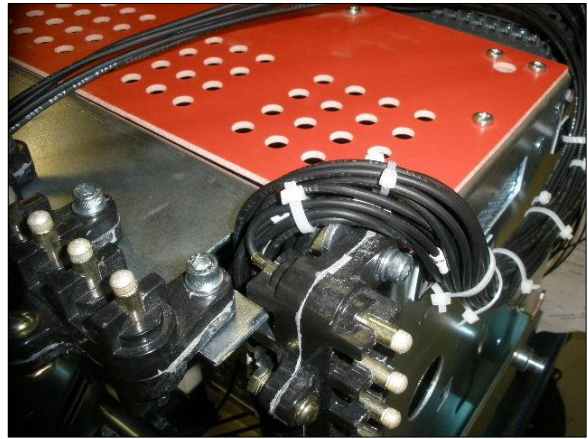


Figure 49. Wires from Secondary Bullets



Wire
Guard
Wire Tie



Wire
Markers

Programmer Secondary Disconnect (Breaker Side—N/A)

Programmer secondary disconnects are not provided on AKD5 legacy LVS breakers. If the customer chooses to use the advanced features of the EntelliGuard ACB, the control wiring needs to be routed from the LVS directly to the secondary disconnect landing points on the cassette assembly of the EntelliGuard ACB cassette. Refer to the tables ([Table 7](#) and [Table 8](#)) featuring the two 39-blocks (A and B) that make up the 78-point secondary-disconnects. Ordering info given here:

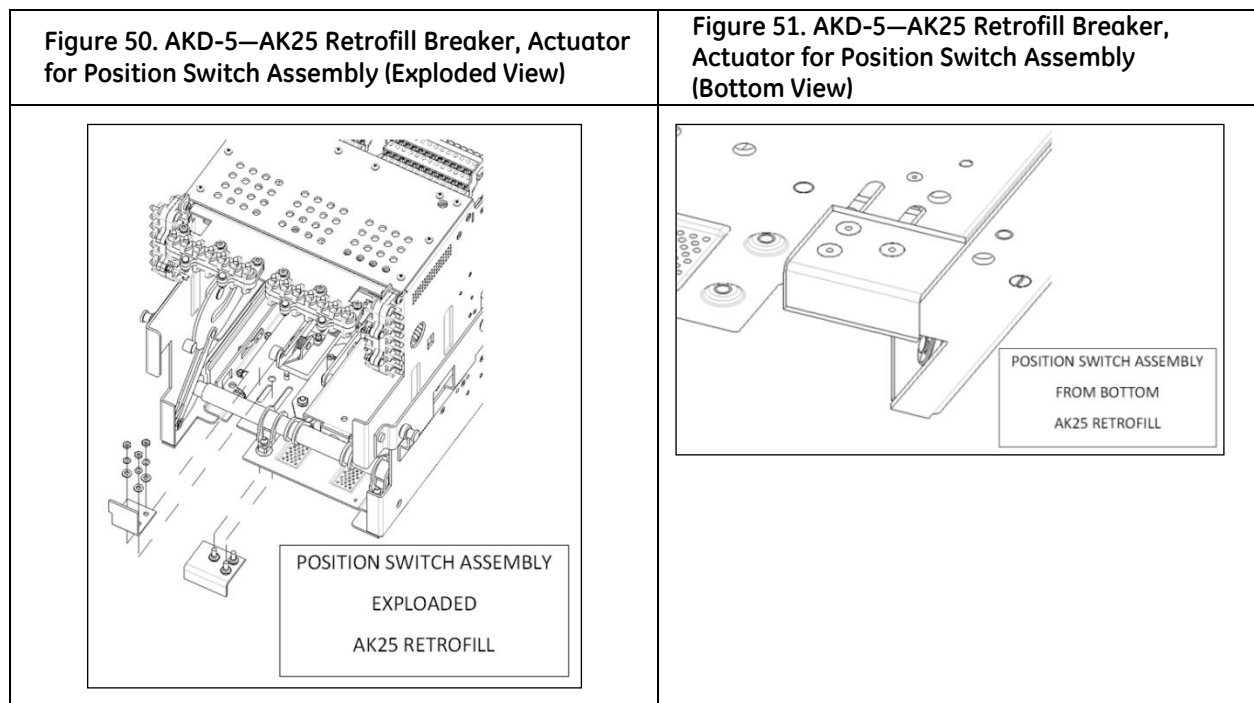
Install Position Switch Actuator (Breaker Side)

| Legacy Breaker | Kit Number |
|----------------|------------|
| AK50 | 10106296G1 |
| AK25 | 10106269G1 |

AK25

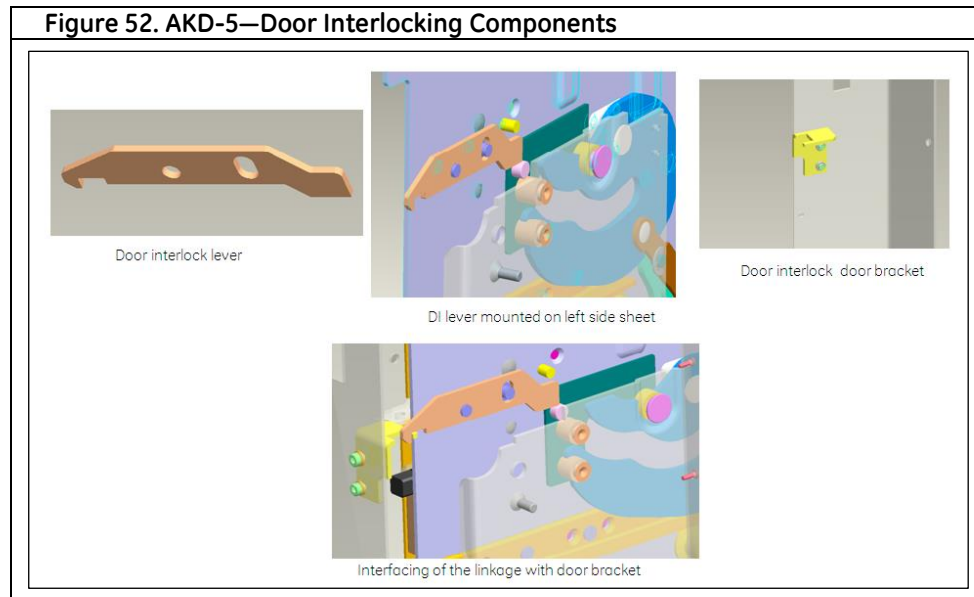
The position-switch actuator assembly for the AK25 should be mounted on the bottom plate of the cassette assembly of the AK25 retrofit. The actual actuator assembly consists of two plates, one on the top (top plate) and one on the bottom of the baseplate. The top plate of the actuator interfaces with the breaker when it is racked in and the motion of the same is transferred to the bottom plate which interfaces with the position switch lever on the legacy compartment.

Completing the racking in of the EntelliGuard breaker into the cassette corresponds to the end of stroke of the position switch system in the compartment for AK25 in AKD-5 LVS. [Figure 50](#) shows the exploded view of the AK25 retrofit position-switch actuator (actually a bracket assembly); [Figure 51](#) displays the assembly from the bottom.



Install Door Interlock System (Breaker Side)

Figure 52 shows the components that make up the AKD-5 retrofit door interlocking assembly:



For the retrofit, instructions for installing the interlocking system on the AKD-5 switchgear are the same as those for EntelliGuard G Circuit Breaker. Refer to the [Installation, Operation, and Maintenance Manual for the EntelliGuard G Circuit Breaker, DEH-41304, 02 Apr 09](#).

Neutral Disconnect Assembly (Breaker Side)

When a legacy AK breaker is replaced with a retrofitted EntelliGuard ACB, the incoming wires from the neutral CTs need to be routed to the cassette secondary-disconnects directly.

Install AKD-5—Neutral Rogowski Current Transformer (CT)

The AKD-5 EntelliGuard R Circuit Breaker uses an open-core Rogowski Current sensor to measure current level vs. an iron core style used in the legacy AK, AKR breakers. For the retrofit to calculate the current levels on a 4-wire circuit, the neutral iron core CT in the cable compartment must be replaced with a Rogowski style CT.

The current transformer comes with the CT-mounted on copper bars matching the same hole-pattern as the existing neutral bar.

The external neutral Rogowski mounting kit comes with three mounting brackets, two fixing screws, two cable ties, one 2-m long twisted pair extension lead and one neutral Rogowski coil.

Remove Existing Iron Core Neutral CT Assembly



- It must be ensured that the supply power to the compartment is turned off/ compartment is de-energized for all the incoming and outgoing circuits of the LVS prior to any work being conducted on it.
 - During the installation and related work on the equipment, it must be ensured that the operator is using the prescribed PPE for the specified tasks.
- Ensure only qualified personnel install, operate, service, and maintain all electrical equipment.

Figure 53 shows a photo of an existing iron core neutral current transformer.



Neutral CT assembly in Cable/Bus Compartment:

1. Verify that the LVS has been de-energized and the breaker in the compartment being retrofitted are switched off and removed from the LVS.
2. Open the door on the rear of the compartment to gain access the cable/bus compartment of the LVS.

The existing neutral CT assemblies are usually mounted vertically on two copper bus bars placed horizontally.

3. Make a note of the neutral disconnect assembly orientation and the wire connections polarity.

This needs to be done to ensure that the assembly is maintained when the new CT assembly is installed.

4. Disconnect the wires attached to the existing CT assemblies and place them in a way that they do not interfere with the replacement of the CT assemblies.
5. Replace the neutral disconnect wiring with the new pared-wire which should be routed directly to the secondary disconnects of the cassette assembly.
6. Unfasten and remove the bolts that hold the neutral disconnects assemblies to the horizontal bus bars. Keep the hardware in a secure location for reassembly.
7. Care should be taken while handling the CT assemblies such that they do not fall down or damage other components within the LVS.
8. Replace the old CT assembly with the Rogowski assembly ([Figure 54](#) and [Figure 55](#) or [Figure 56](#) and [Figure 57](#)) on the horizontal bus bars; and fasten the Rogowski using the hardware previously removed. Orientation of the new CT assembly should match that of the legacy which was referenced in Step 3.
9. Connect the wires back to the Rogowski CT assembly leads. Maintain the same polarity as that of the legacy CT connections which were noted during Step 3.
10. Check for continuity from the CT leads to the secondary disconnects on the retrofit EntelliGuard ACB.
11. The new Rogowski assemblies are installed and ready for use.

Tools required: Wrenches, Wire stripper, wire cutter, continuity tester

Figure 54. AKD-5—AK25 Neutral Bus Rogowski ASM 10108212

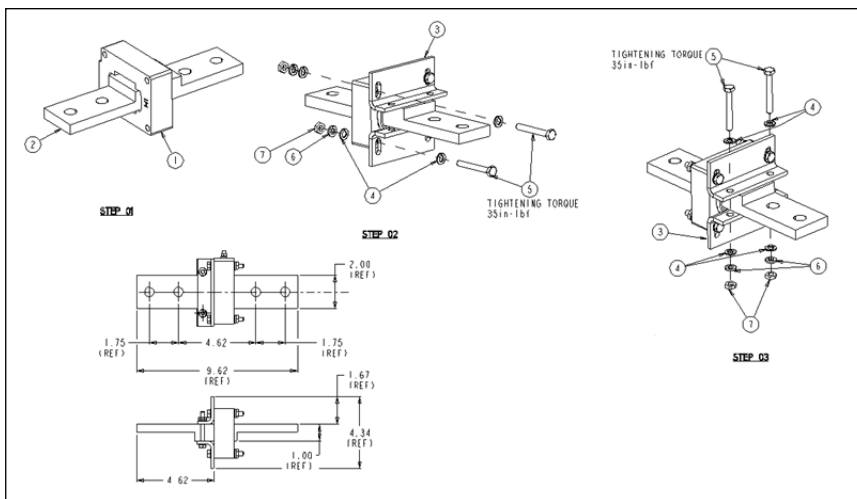


Figure 55. Neutral Bus Rogowski ASM 10108212 Photo

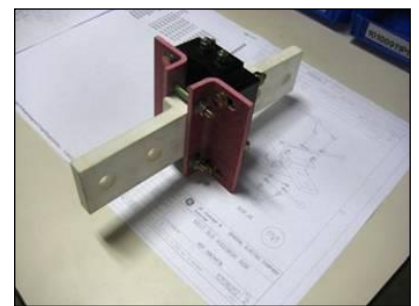


Figure 56. AKD-5—AKT50 2000A Neutral Bus Rogowski ASM 10108216G7

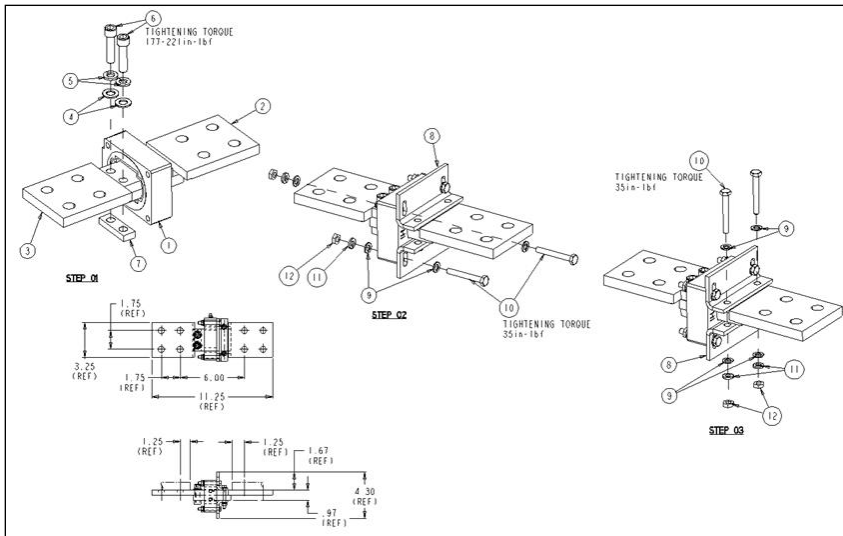
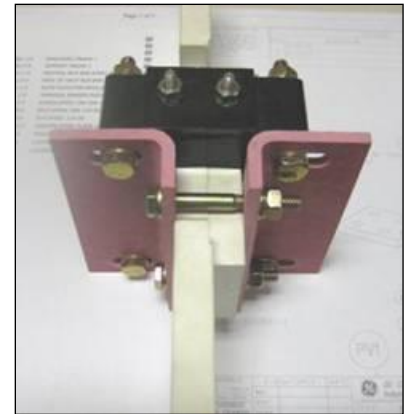


Figure 57. Neutral Bus Rogowski ASM 10108216G7 Photo



AKD-5—Neutral Sensor Packaging



- Ensure only qualified personnel install, operate, service, and maintain all electrical equipment.

- It must be ensured that the supply power to the compartment is turned off/ compartment is de-energized for all the incoming and outgoing circuits of the LVS prior to any work being conducted on it.
- During the installation and related work on the equipment, it must be ensured that the operator is using the prescribed PPE for the specified tasks.

- The Neutral Sensor is constructed using a phase sensor encapsulated appropriately to meet insulation and durability requirements.
- Lead wires are UL-recognized type 18AWG or larger, rated at 600V.
- Lead wires are 6 feet in length, minimum.
- Lead wires are colored white and black.
- The white wire is connected to the “positive” polarity termination.
- The black wire is connected to the “negative” polarity termination.

- Sensor window cross section conforms to criteria as found in the table below ([Table 9](#)):

| Table 9. Frame Ratings and Sensor Areas | |
|---|---|
| Frame & Rating | Sensor Window minimum area (in ²) |
| Frame 1 / 2000A | 2.0 |
| Frame 2 / 3200A | 3.2 |
| Frame 3 / 6400A | 6.4 |

The Frame 3 neutral sensor is implemented as two separate sensors, similarly to the phase sensors in the circuit breaker. Frame 3 neutral bus assemblies provide two independent parallel conductors in the neutral bus such that the neutral current is divided between the two sensors.

A special neutral bus section is provided within the switchgear to accommodate the specific form factor of each Rogowski—this is not the design responsibility of the Rogowski vendor.

- Encapsulation materials are UL recognized and suitable for operation at 130C.
- Neutral sensors of a given rating match all characteristics of the phase sensors.

AKD-5—Multi-Source Ground Fault

Retrofills can be used in the following ground fault applications:

- Single source feeder breakers, 3-wire or 4-wire
- Main circuit breakers, 3-wire or 4-wire

When multi-sources are present with the ground fault detection on the trip unit desired, then an external GF summing CT scheme must be implemented. This applies to Main—Tie—Main systems or systems with a main source and then a back-fed generator source.

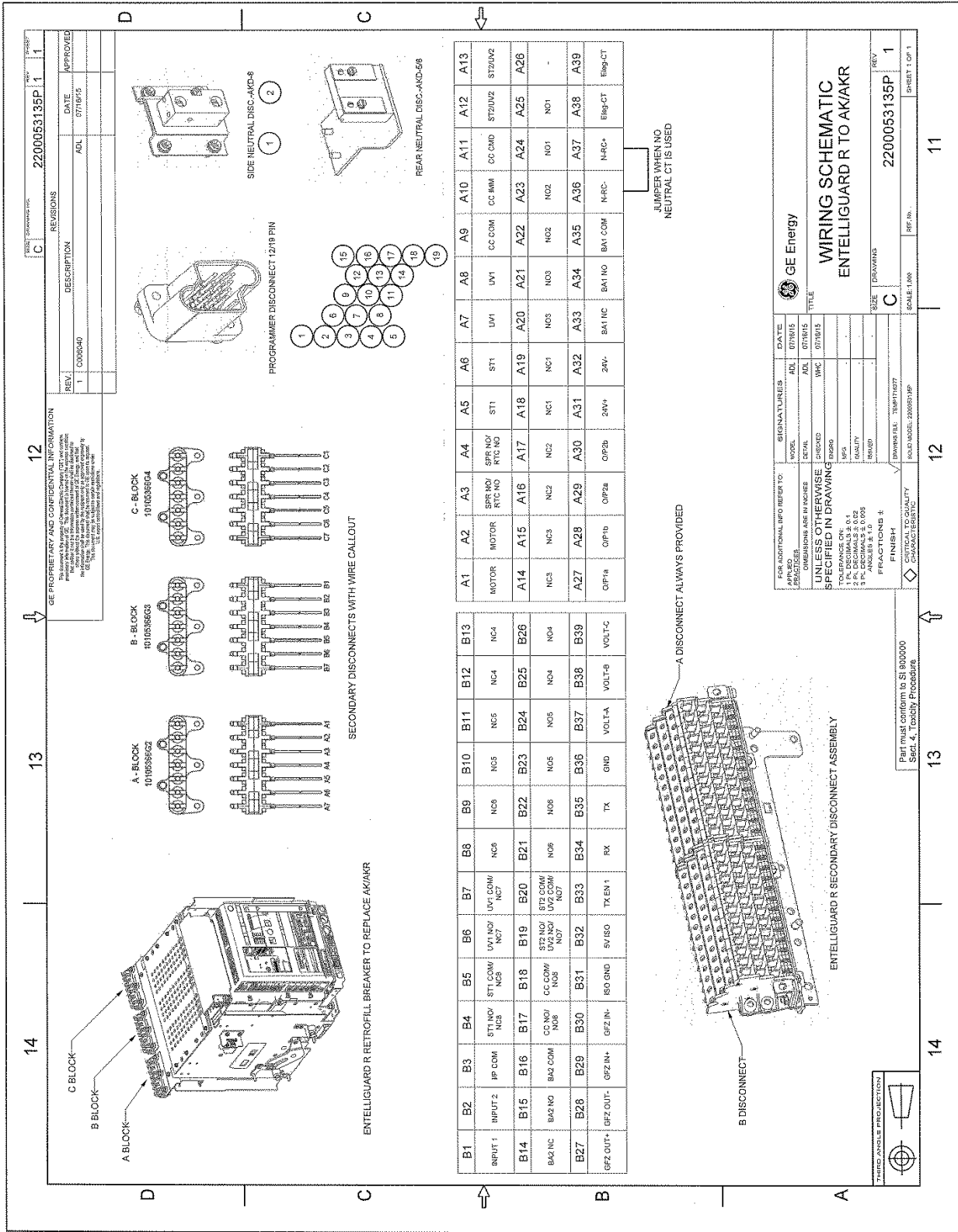
Contact factory for MSGF applications.

Remove and Replace AKD-5—Existing Door



- It must be ensured that the supply power to the compartment is turned off/ compartment is de-energized for all the incoming and outgoing circuits of the LVS prior to any work being conducted on it.
 - During the installation and related work on the equipment, it must be ensured that the operator is using the prescribed PPE for the specified tasks.
- Ensure only qualified personnel install, operate, service, and maintain all electrical equipment.
1. To remove existing compartment door(s), refer to your manual on how to remove the legacy doors.
 2. To install new door, refer to the [Retrofill Door Assemblies, DEH-41563](#).

Neutral disconnect and programmer disconnect plugs are not used for AKD5. Points provided as reference for wiring purposes only.



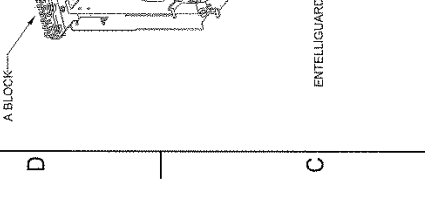
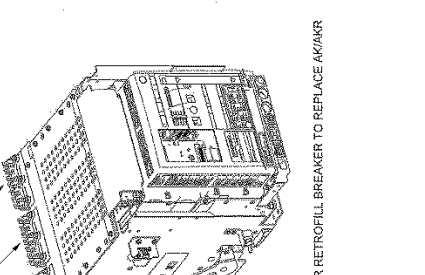
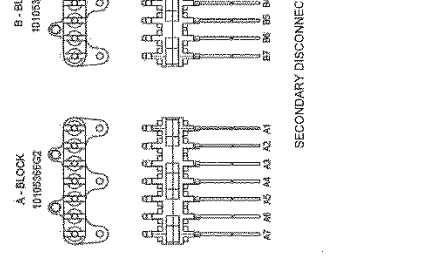
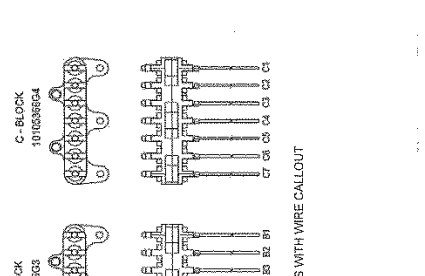
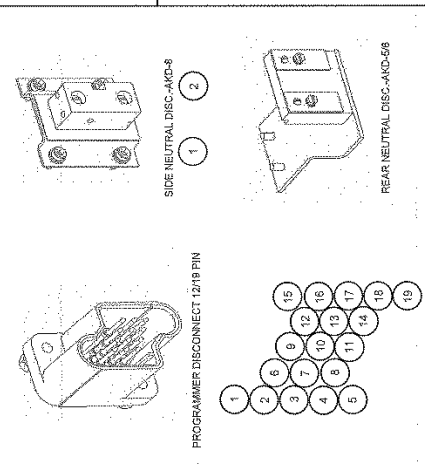
| REV. | DESCRIPTION | DATE | APPROVED |
|------|-------------|----------|----------|
| 1 | 006540 | 07/18/15 | |

| REV. | DESCRIPTION | DATE | APPROVED |
|------|-------------|----------|----------|
| 1 | 006540 | 07/18/15 | |

| REV. | DESCRIPTION | DATE | APPROVED |
|------|-------------|----------|----------|
| 1 | 006540 | 07/18/15 | |

| REV. | DESCRIPTION | DATE | APPROVED |
|------|-------------|----------|----------|
| 1 | 006540 | 07/18/15 | |

| REV. | DESCRIPTION | DATE | APPROVED |
|------|-------------|----------|----------|
| 1 | 006540 | 07/18/15 | |



| Terminal | Function | Wiring | Notes |
|----------|----------|--------------|-------|
| B1 | INPUT 1 | ST1 COM/ NCS | |
| B2 | INPUT 2 | IP COM | |
| B3 | B16 | CC COM/ N08 | |
| B4 | B17 | CC NO/ N08 | |
| B5 | B18 | ST1 COM/ NCS | |
| B6 | B19 | ST2 NO/ N07 | |
| B7 | B20 | ST2 COM/ N07 | |
| B8 | B21 | UV1 NO/ N07 | |
| B9 | B22 | UV1 COM/ N07 | |
| B10 | B23 | UV2 NO/ N08 | |
| B11 | B24 | UV2 COM/ N08 | |
| B12 | B25 | NC4 | |
| B13 | B26 | NC4 | |
| B14 | B27 | BA2 NO/ N08 | |
| B15 | B28 | BA2 NO/ N08 | |
| B16 | B29 | BA2 NO/ N08 | |
| B17 | B30 | CC NO/ N08 | |
| B18 | B31 | CC COM/ N08 | |
| B19 | B32 | ST2 NO/ N07 | |
| B20 | B33 | ST2 COM/ N07 | |
| B21 | B34 | TX EN 1 | |
| B22 | B35 | TX EN 1 | |
| B23 | B36 | ISO GND | |
| B24 | B37 | ISO GND | |
| B25 | B38 | ISO GND | |
| B26 | B39 | ISO GND | |
| B27 | B40 | ISO GND | |
| B28 | B41 | ISO GND | |
| B29 | B42 | ISO GND | |
| B30 | B43 | ISO GND | |
| B31 | B44 | ISO GND | |
| B32 | B45 | ISO GND | |
| B33 | B46 | ISO GND | |
| B34 | B47 | ISO GND | |
| B35 | B48 | ISO GND | |
| B36 | B49 | ISO GND | |
| B37 | B50 | ISO GND | |
| B38 | B51 | ISO GND | |
| B39 | B52 | ISO GND | |
| B40 | B53 | ISO GND | |
| B41 | B54 | ISO GND | |
| B42 | B55 | ISO GND | |
| B43 | B56 | ISO GND | |
| B44 | B57 | ISO GND | |
| B45 | B58 | ISO GND | |
| B46 | B59 | ISO GND | |
| B47 | B60 | ISO GND | |
| B48 | B61 | ISO GND | |
| B49 | B62 | ISO GND | |
| B50 | B63 | ISO GND | |
| B51 | B64 | ISO GND | |
| B52 | B65 | ISO GND | |
| B53 | B66 | ISO GND | |
| B54 | B67 | ISO GND | |
| B55 | B68 | ISO GND | |
| B56 | B69 | ISO GND | |
| B57 | B70 | ISO GND | |
| B58 | B71 | ISO GND | |
| B59 | B72 | ISO GND | |
| B60 | B73 | ISO GND | |
| B61 | B74 | ISO GND | |
| B62 | B75 | ISO GND | |
| B63 | B76 | ISO GND | |
| B64 | B77 | ISO GND | |
| B65 | B78 | ISO GND | |
| B66 | B79 | ISO GND | |
| B67 | B80 | ISO GND | |
| B68 | B81 | ISO GND | |
| B69 | B82 | ISO GND | |
| B70 | B83 | ISO GND | |
| B71 | B84 | ISO GND | |
| B72 | B85 | ISO GND | |
| B73 | B86 | ISO GND | |
| B74 | B87 | ISO GND | |
| B75 | B88 | ISO GND | |
| B76 | B89 | ISO GND | |
| B77 | B90 | ISO GND | |
| B78 | B91 | ISO GND | |
| B79 | B92 | ISO GND | |
| B80 | B93 | ISO GND | |
| B81 | B94 | ISO GND | |
| B82 | B95 | ISO GND | |
| B83 | B96 | ISO GND | |
| B84 | B97 | ISO GND | |
| B85 | B98 | ISO GND | |
| B86 | B99 | ISO GND | |
| B87 | B100 | ISO GND | |

GE Energy

WIRING SCHEMATIC
ENTELEGUARD R TO AKIAR

SCALE 1:100

REV 1

| FOR ADDITIONAL INFO REFER TO: | SIGNATURES: | DATE: |
|-------------------------------|-------------|-------|
| MODEL | DATE | DATE |
| DRAWING NO. | DATE | DATE |
| REVISION | DATE | DATE |

UNLESS OTHERWISE SPECIFIED IN DRAWING

TOLERANCES ON:

- 1. DIMENSIONS: ± 0.1
- 2. ANGLES: ± 0.2
- 3. HOLE LOCATIONS: ± 0.05

FINISH: CRITICAL TO QUALITY

CHARACTERISTIC

Part must conform to SI 990000 Sect. 4, Tolerance Procedure

Notes

GE
Industrial Solutions

41 Woodford Avenue
Plainville, CT 06062
www.geindustrial.com

© 2015 General Electric Company



*Trademark of the General Electric Company and/or its subsidiaries

DEH-41547 Rev. 3 (07/15)

