

GE
Industrial Solutions

EntelliGuard*^R Retrofill

Circuit Breakers 800-2000A

AKD-6 Installation Manual

General Electric AKD-6 Low Voltage Switchgear is a free-standing assembly of metal-enclosed power circuit breakers. It may also be a part of a single-ended or double-ended load center unit substation. This manual applies to EntelliGuard R breakers for OEM substructures using AKR-#B-30/50/T50 legacy breakers and AKD-6 switchgears using AKR-#A-30/50/T50 legacy breakers.



imagination at work

Table of Content

Preface	3
Hazards.....	3
Danger.....	3
Warning.....	4
Caution.....	4
Notice or Note.....	5
Warranty.....	5
Trademarks and Patents.....	5
Standards.....	5
Document Conventions.....	5
Related Publications.....	6
Service and Support.....	6
Estimated Time to Complete Tasks.....	6
Description	6
Product Specs.....	6
Weight (lbs).....	6
History and Types	8
AKD.....	8
AKD-5—AK25/AK50.....	8
AKD-6—AKR30H/AKR30L/AKR50H/AKRT50H.....	8
AKD-8—AKR30H/AKR30L/AKR50H/AKRT50H.....	8
AKD-10—WPS-08, WPH-08, WPX-08, WPS-16, WPH-16, WPS-20.....	9
AKD-6—Breaker Models.....	10
Mechanical Drawings.....	11
AKD-6—Compartment	12
Interior.....	12
Unpack Retrofill Circuit Breaker	14
Quality.....	15
Information Label.....	15
Product and Catalog Serial Numbers.....	15
Remove Circuit Breaker from Container.....	16

Inspect.....	16
Use Lifting Truck.....	16
Store Circuit Breaker	17
Check Before Installing.....	17
Clean and Grease Breaker	18
Rack Out Legacy or Existing CB	18
Install Secondary Disconnect Bullets (Breaker).....	19
Wire Secondary Disconnect Assembly—AKR30/30H/50/50H.....	21
Figure 10. Typical AKD-6 Wiring Diagram	23
Installing Position Switch Actuator (Breaker)	24
Installing Door Interlock System (Breaker).....	25
AKD-6 Key Interlock	27
Installing Neutral Disconnect Assembly (Breaker).....	27
19-Pin Programmer Secondary Disconnect (Breaker).....	28
Figure 20. Wiring for Programmer Disconnect (19-Pin)	30
Install or Insert AKD-6 Retrofill.....	32
Remove and Replace Existing Door	39
Prepare Switchgear Compartment.....	39
Install Neutral CT Assembly (Bus Compartment).....	41
Multi-Source Ground Fault	42
Install 19-Pin Programmer Secondary Disconnect (Compartment)	43

Preface

Hazards

The following important highlighted information appears throughout this document to warn of potential hazards or to call attention to information that clarifies a procedure. Carefully read all instructions and become familiar with the devices before trying to install, operate, service, or maintain this equipment.


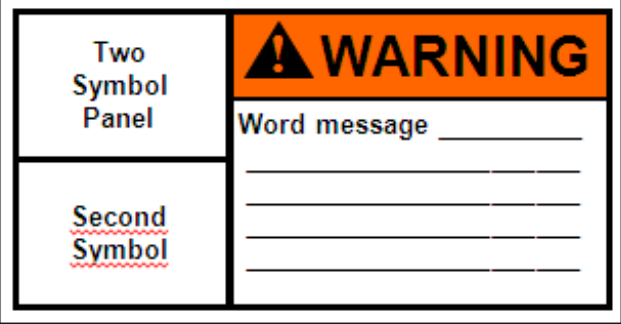
Danger

This indicates a hazardous situation which, if not avoided, results in death or serious injury. A variety of electrical hazards warnings are displayed here and are applied to installation manuals. These are standard or generic alerts and labels that must be taken quite seriously when installing Retrofill circuit breakers in AKD switchgear and when working with potentially dangerous electrical equipment ([Table 1](#)). There are also dangers, pertaining to product safety, that need to be custom-written for particular or specific circumstances ([Table 2](#)).

Table 1. Generic Danger Alerts and Labels Used for Documentation and Dangerous Equipment	Table 2. Custom Danger Alerts and Labels Used for Documentation and Dangerous Equipment
<p>The image shows a collection of standard electrical safety labels. At the top left is a 'DANGER' label with a lightning bolt symbol and the text 'Arc flash and shock hazard. Follow ALL requirements in NFPA 70E for safe work practices and for personal Protective Equipment.' To its right is another 'DANGER' label with a lightning bolt symbol and the text 'Shock and arc flash explosion hazards. Follow ALL requirements in NFPA 70E for safe work practices and for Personal Protective Equipment.' Below these are three more labels: 'HAZARDOUS VOLTAGE. Disconnect power before servicing.', 'Electrical hazard.' with a hand symbol, and 'High Voltage' with a lightning bolt symbol and the text 'Electrical hazard Authorized personnel only'. At the bottom left is a 'DANGER' label with a lightning bolt symbol and the text 'Arc Flash and Shock Hazard Appropriate PPE Required Follow all safety procedures and wear proper PPE in accordance to NFPA 70E. Failure to comply can result in serious injury or death.' At the bottom right is a 'DANGER' label with a lightning bolt symbol and the text '440 VAC Dangerous Voltages Exist. Contact will cause electrical shock or burn. Lockout/Tagout before servicing.' To its right is a blue circular lockout/tagout symbol.</p>	<p>The image shows two examples of custom danger labels. The top one is a rectangular label with a red 'DANGER' header. Below the header, on the left, is a box labeled 'Symbol Panel' and on the right is a box labeled 'Word message' with several horizontal lines for text. The bottom one is a smaller rectangular label with a red 'DANGER' header and a 'Word message' field with several horizontal lines for text.</p>

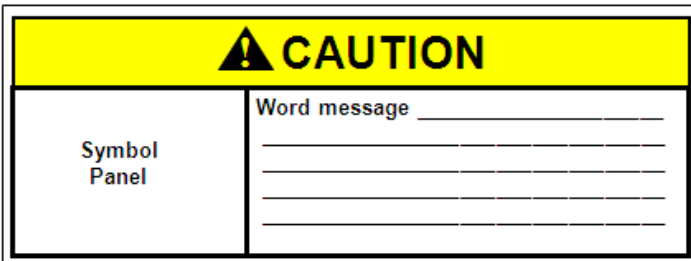
Warning

This indicates a hazardous situation, which, if not avoided, would result in death or serious injury. A variety of electrical hazards warnings are displayed here and are applied to installation manuals. These are standard or generic alerts and labels that must be taken quite seriously when installing Retrofill circuit breakers in AKD switchgear and when working equipment that can cause injury, but may not be necessarily fatal ([Table 3](#)). There are also warnings, pertaining to product safety, that need to be custom-written for particular or specific circumstances ([Table 4](#)).

<p>Table 3. Generic Warning Alerts and Labels Used for Documentation and Dangerous Equipment</p>	<p>Table 4. Custom Warning Alerts and Labels Used for Documentation and Dangerous Equipment</p>
	

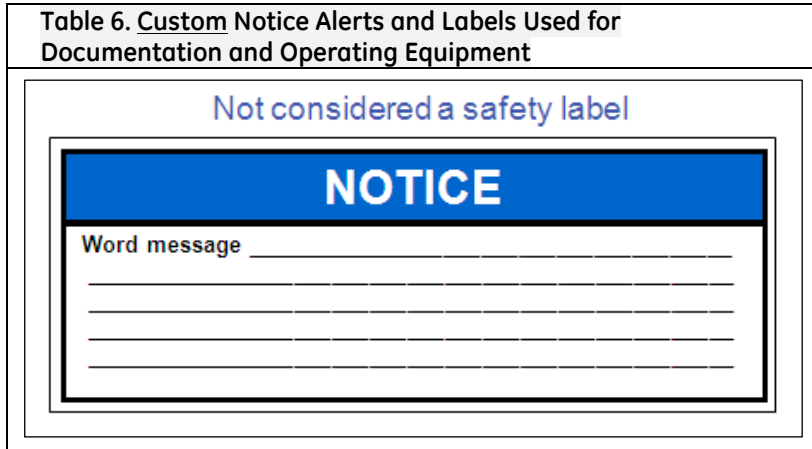
Caution

This pertains to a hazard that has a low level of risk, which means that if not avoided, it could result in minor or moderate injury. It also indicates that failure to comply with instructions may result in product damage. The label here requires a specific message that targets a special product or procedure ([Table 5](#)).

<p>Table 5. Custom Caution Alerts and Labels Used for Documentation and Operating Equipment</p>	
	

Notice or Note

This indicates important information in that it aids in job performance, that is, a notice or note is used to notify practices not related to personal injury (*Table 6*).



Warranty

This document is based on information available at the time of its publication. While efforts have been made to ensure accuracy, the information contained herein does not cover all details or variations in hardware and software, nor does it provide for every possible contingency in connection with installation, operation, and maintenance.

Features may be described herein that are not present in all hardware and software systems. GE Energy assumes no obligation of notice to holders of this document with respect to changes subsequently made. GE Energy makes no representation or warranty, expressed, implied, or statutory, with respect to, and assumes no responsibility for the accuracy, completeness, sufficiency, or usefulness of the information contained here in. No warranties of merchantability or fitness for purpose shall apply.

Contact your local sales office if further information is required concerning any aspect of EntelliGuard R Circuit breaker operation or maintenance.

Trademarks and Patents

EntelliGuard* R
EntelliGuard* TU
EntelliGuard* Trip Unit
EntelliGuard* G

Standards

Agency Certification	
Standard Number:	Title:
ANSI C37.13,16,17,20.1,,50,51,59	Low-Voltage AC Power Circuit Breakers
UL 1066	Low-Voltage AC and DC Power Circuit Breakers Used in Enclosures

Document Conventions

Topics and text are divided into primary, secondary, and tertiary paragraph headings.

Related Publications

Publication	Publication Number
Brochure	DEA-532
Snapshot	DEE-543
Installation Manual AKD8	DEH-41549
Installation Manual AKD10	DEH-41550
Installation Manual AKD6	DEH-41548
Installation Manual AKD5	DEH-41547
Accessory: Door Interlock (Door Interlock Kit)	DEH-41529
Accessory Retrofill Doors Assembly	DEH-41563
Accessory: Position Switch Plate & Position Switch Assembly & Wiring (Position Switch Kit)	DEH-41530
Accessory: Neutral Rogowski CT Disconnect (Neutral Assemblies)	DEH-41531
Accessory: Programmer Disconnects	DEH-41532
Accessory: Finger Clusters (Cluster Assemblies)	DEH-41533
Accessory: Secondary Disconnects	DEH-41534
FAQ	DEQ-171
Application Guide	DET-753
Guideform Spec	DET-754
Spare/Renewal Parts Guide	DET-755

Service and Support

In addition to the local field sales office and service teams, GE also has a dedicated AfterMarket team to assist customers with legacy information, selection, ordering, and upgrading.

Estimated Time to Complete Tasks

It takes about 20 minutes to install a feature-for-feature LSI assembly. This includes racking out the old breaker, racking in the new breaker, and replacing the door. If new options are desired, or if it's a 4-wire LSI circuit or modifications are needed to the cubicle, then additional time is required. Time also does not include wiring the secondary disconnect on the Retrofill.

Description

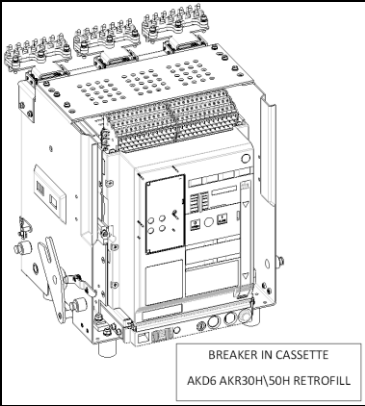
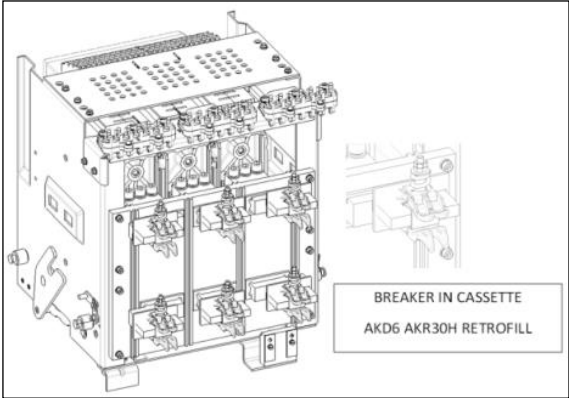
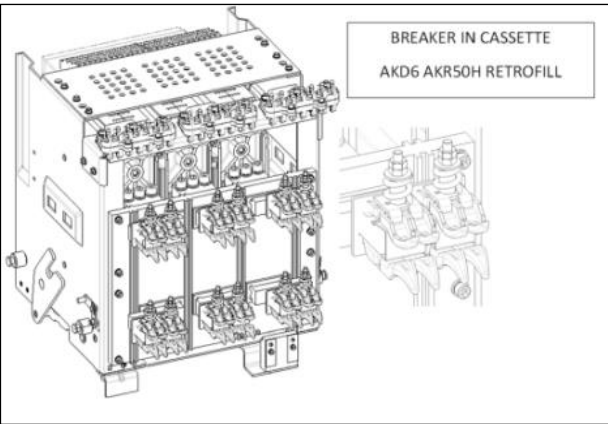
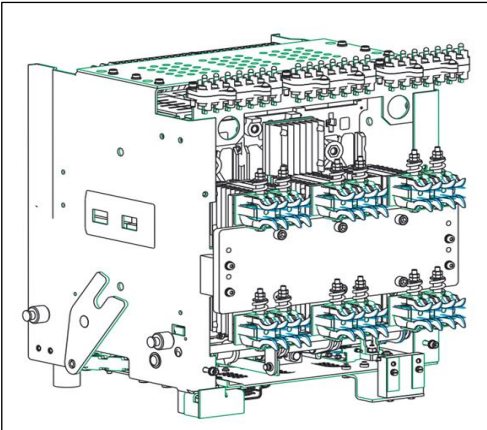
Product Specs

Weight (lbs)

Retrofill Breaker	Weight	Box Weight 10101653P1	Pallet 10101650P1 Wt	Accessories Wt	Total Weight
AKD6-1600A	213	16	33	2	264
AKD6-2000A	238	16	33	2	289

Views

General Electric AKD-6 Low Voltage Switchgear is a free-standing assembly of metal-enclosed of power circuit breakers. It may also be a part of a single-ended or double-ended load center unit substation. One particular feature of the AKD-6 is that the breaker is built into the cassette. *Figure 1* shows the AKD-6 EntelliGuard R Retrofill breaker permanently encased in its cassette (front view). *Figure 2* shows also the AKD-6 EntelliGuard R Retrofill in the cassette (rear view). *Figure 3* presents the AKR50H (AKD-6) with four-fingered clusters. *Figure 4* presents the AKRT50H (2000A) with four-fingered clusters and redesigned braced plate.

<p>Figure 1. AKD-6—AKR30H\50H Breaker in Cassette (Front View)</p> 	<p>Figure 2. AKD-6—AKR30H Breaker in Cassette (Rear View)</p> 
<p>Figure 3. AKD-6—AKR50H Breaker in Cassette (Rear View) Figure 4. AKD-6—AKRT-50H Breaker in Cassette (Rear View)</p>	
	

The EntelliGuard R Circuit Breaker is suitable for application on power systems up to 600 VAC 50/60 Hz.

History and Types

AKD

AK—Power Circuit Breaker Equipment

D—Drawout circuit breaker construction

Manufactured from 1951 to 1975 were these: all bolted, copper bus design, all drawout breakers—AK-1, -2, -3, -15 / 25 / 50 / 75 / 100; the 4000A-max bus rating. Back then, breakers had a ratcheting drawout mechanism, with an open-door drawout. Breakers were painted ANSI 61, light gray, manufactured in Philadelphia from 1951 to the mid-60s and in Burlington, Iowa from the mid-60s to 1975.

The breaker compartment was a welded assembly, and the equipment frame was bolted. Breaker boxes were stacked to make a vertical section with equipment frame around the breaker boxes. There were no bus compartment barriers, just an open bus design. Ring silver-plating was applied to bolted connections.

AKD-5—AK25/AK50

Manufactured from 1960 until 1977, the aluminum bus had copper that was “flash-butt welded” to the aluminum at bolted connections. During that time, AK-2A, 3A -25 / 50 / T50 / 75 / 100 (“A” signifies AKD-5 drawout) were produced. Breakers up to 2000A had primary finger clusters. 3000 & 4000A breakers had a circular primary finger cluster arrangement in the switchgear compartment. Pull-lanyard drawout mechanism on early design was replaced by a single jackscrew mechanism and then later replaced by a double jack-screw mechanism. Featured is a closed-door, drawout with inner house breaker compartment. Two bus levels are available with a ring bus used at 4000A. Particulars include: welded/riveted frame, bus compartment barriers, line/load separation barriers on mains and ties, isolation barriers on transformer transitions, copper runbacks on feeder breakers, ring silver-plating on copper, and aluminum bus un-plated (welded connections). The switchgear is painted sand-gray (beige), with some instrument doors painted blue. AKR-30/50 in 22”-wide sections were introduced in AKD-5 construction, early 70s. AK25s and AK50s were also available as substructure kits for OEMs to build around customer gear.

Note: All legacy AK & AKR breakers have a draw out letter code “A”. Entelliguard R retrofill breaker for this gear will have a catalog number beginning with R1 for AK replacements or R2 for AKR-30/50 replacements.

AKD-6—AKR30H/AKR30L/AKR50H/AKRT50H

The AKD-6 was manufactured in Salisbury, NC from 1977 to 1981. Some AKD-5s, which were built in Salisbury from 1975 until 1977, got name-plated as AKD-6. There is no “flash-butt” welded aluminum to copper. Aluminum bus is tin-plated and bolted at shipping splits (but welded everywhere else). Copper bus design has ring silver plating at bolted joints. AKR-75 / 100s were introduced during this time. Stab-and-finger connections on 3200A and 4000A breakers were improvements, versus the round the primary disconnects located on the AKD-5s.

The AKD-6 uses inner-house drawout breaker compartments on the 800—2000A breaker compartments. They are painted ANSI 61 light gray and breakers have ECS or SST trip units.

AKD-6 should mark a shift away from all AK breakers and to AKR breakers. The AKR-30/50/50H/T50 breakers used in AKD6 have a shallow 1” steel front escutcheon are drawout letter code “A” i.e. AKR-4A-30 and will be replaced by an EntelliGuard R with a catalog number beginning with **R2**. The AKR-30/50/50H/T50 breakers sold to OEMs for their switchgear have a 5” deep plastic front escutcheon & spring loaded sliding “picture frame”. These are draw out letter code “B” i.e. AKR-4B-30 which will be replaced by an EntelliGuard R with a catalog # beginning with **R5**.

AKD-8—AKR30H/AKR30L/AKR50H/AKRT50H

The AKD-8 was manufactured in Salisbury, NC from 1980 to 1984 and in Burlington, Iowa from 1984 to 1999. It was mostly replaced by AKD-10 in 1999 to 2000 but was available thru 2015. Model 1 and 2 have extruded

vertical bus. Model 2 was introduced in 1983 to accommodate revised wire harness routing. Model 3 was introduced in 1991, using a flat bar vertical bus. AKR breakers use MicroVersaTrip 9, MVT RMS9, EPIC, MVT Plus, MVT PM, or EntelliGuard TU trip units. Aluminum bus was removed from the design in 1996 in favor of the standard tin-plated copper bus (silver plated optional).

The AKR-30/50/50H/T50 breakers used in AKD8 have 5" deep plastic front escutcheon & spring loaded sliding "picture frame". They are drawout letter code "D" i.e. AKR-7D-30. In AKD-8, most 800-2000A breakers are "feeder" breakers with vertical lower stud & primary disconnect fingers clusters, but 800-2000A breakers designated as "Main" breakers, have horizontal lower finger clusters, which is the same as "D" letter code breakers sold to OEM's. A lower stud rejection bracket differentiates between lower stud orientations. EntelliGuard R breakers with a catalog number beginning with **R3** replace an AKR-30/50/50H/T50 breaker with vertical lower stud & fingers. EntelliGuard R breakers with a catalog number beginning with **R6** replace an AKR-30/50/50H/T50 breaker with horizontal lower stud & fingers.

AKD-10—WPS-08, WPH-08, WPX-08, WPS-16, WPH-16, WPS-20

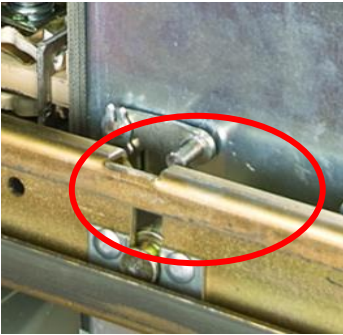

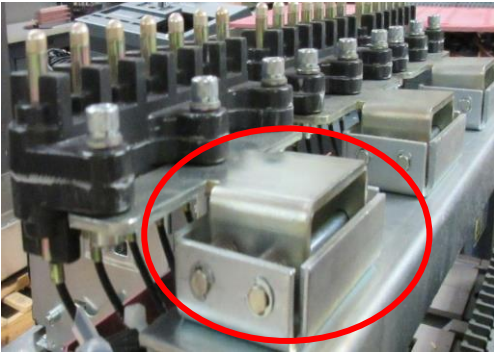

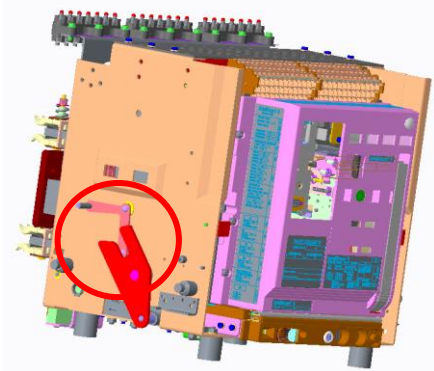
AKD-10 was manufactured in Burlington, IA from 1999 thru 2015. The switchgear compartment sizes and main & vertical bus arrangements are the same as AKD-8 Model 3. The compartments have pull-out rails. AKD-10 uses WavePro * drawout-only style breakers. All breakers have 4 rollers which align with the compartment rails. The secondary control wiring for all functions is connected thru either one or two 36 point secondary disconnects with gold plated contacts. Secondary control wiring terminates at fixed standard locations on the 36 point disconnects. Each breaker has a pump style manual charging handle and manual push OPEN and Push CLOSE buttons. The front escutcheon is 5" deep with a sliding picture frame, but is wide enough so the trip unit and new style bell alarm are visible thru the front door of the switchgear. EntelliGuard R breakers with a catalog number beginning with **R7** will replace a WavePro breaker with a catalog number beginning with WE or W1. EntelliGuard R breaker with a catalog number beginning with **R8** will replace a WavePro breaker with a catalog number beginning with WS or W2. Note GE Switchboard plants initially shipped "WS" style breakers and later shifted to "WE" style breakers to be consistent with GE Switchgear from Burlington, Iowa.

AKD-6—Breaker Models

Following table depicts the key differences between Model 1 & 2 AKD6 Retrofill breakers (800-1600A).

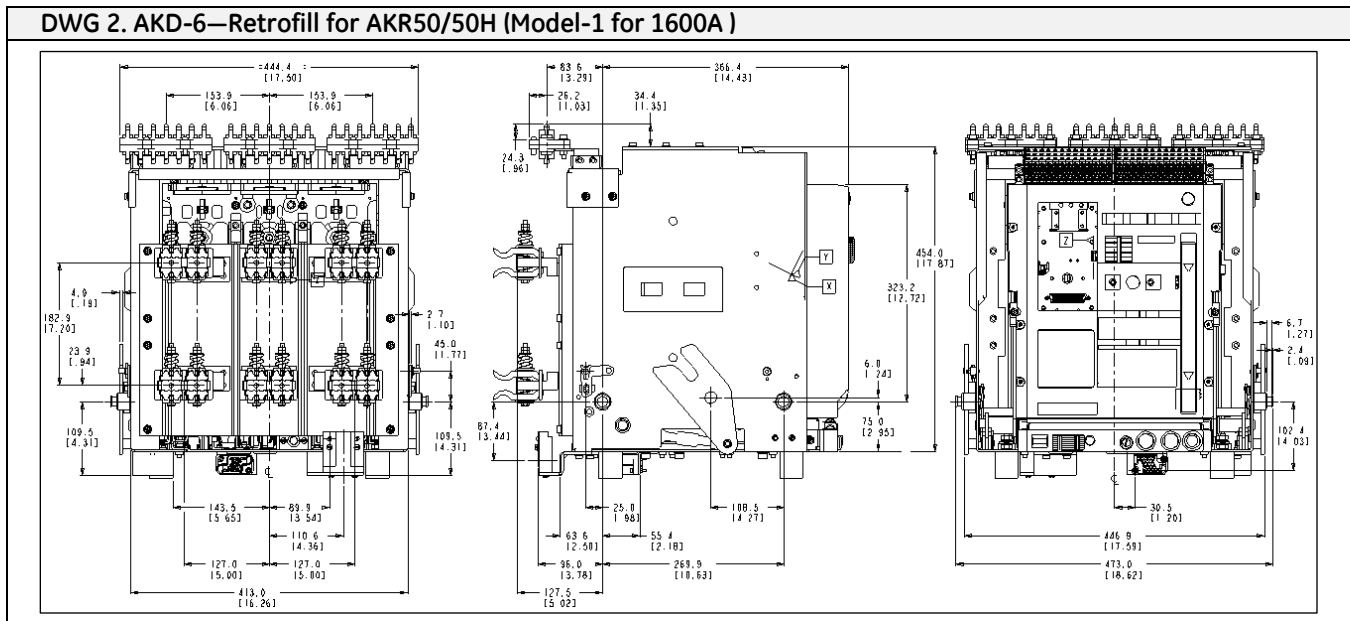
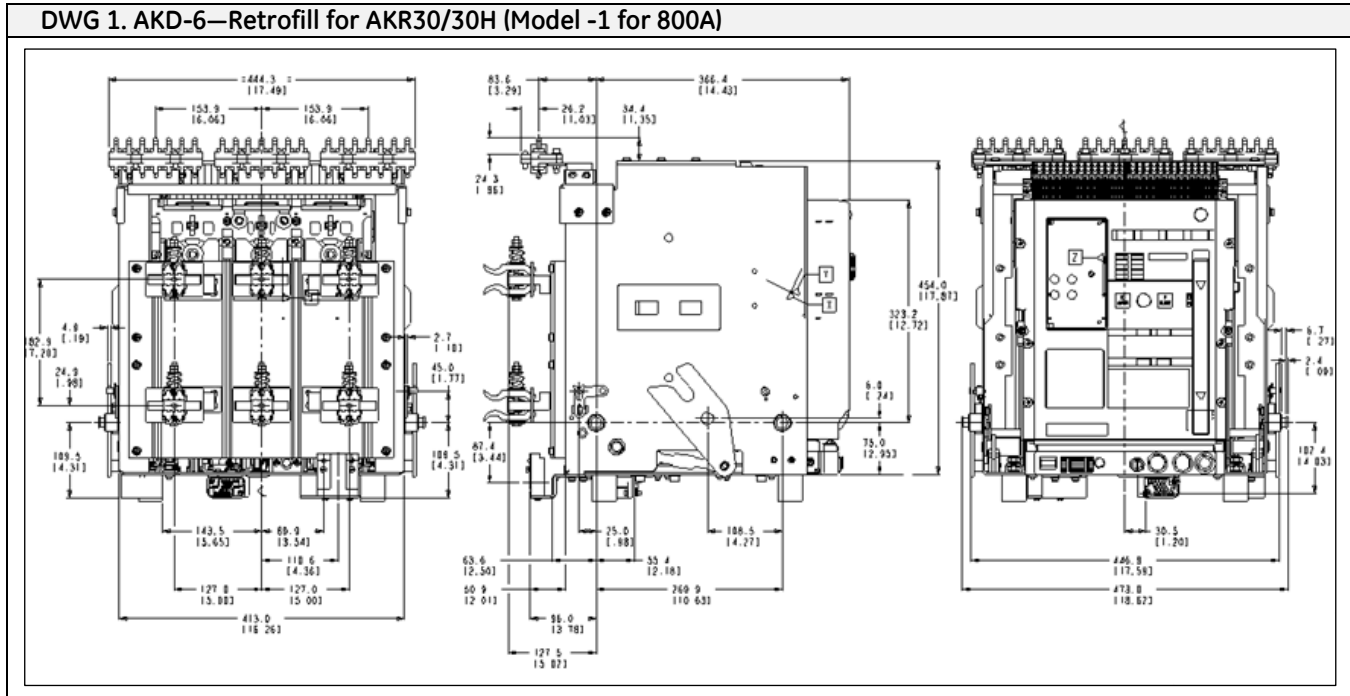
Note: All features of Model 2 (800-1600A) Retrofill breakers are incorporated in all the 2000A breakers.

Breaker Model Comparison Table

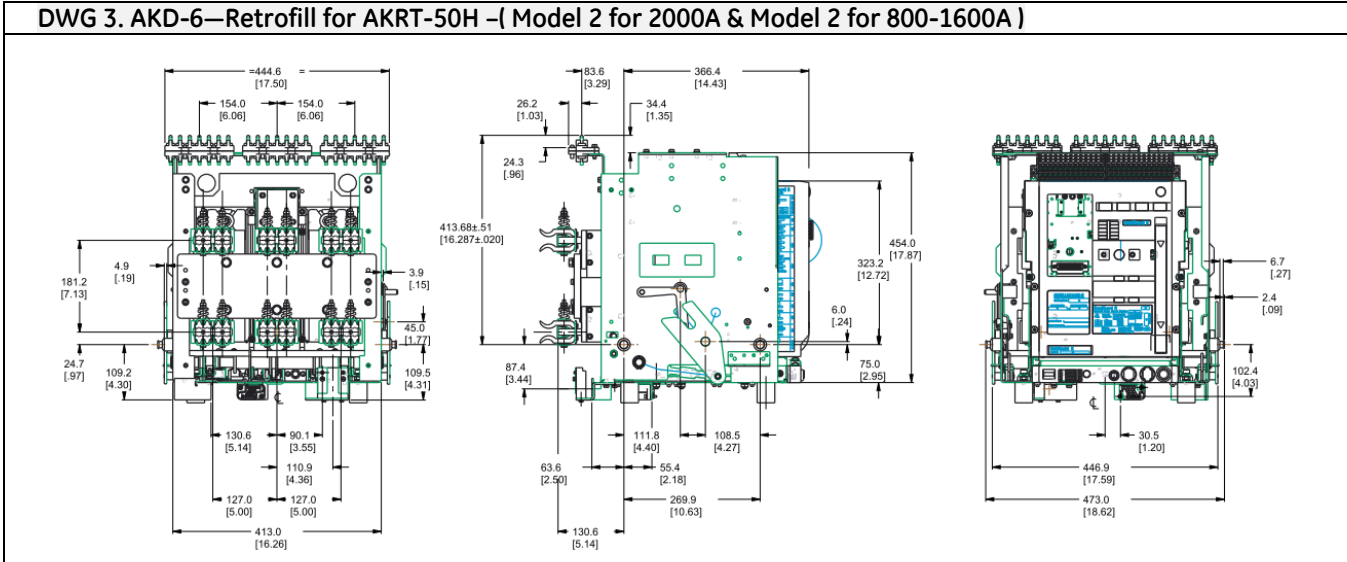
Feature	Model 1 Retrofill Breaker (800-1600A)	Model 2 Retrofill Breaker (800-1600A & 2000A)
<p>Rail latch defeat</p>	<p>Achieved by breaker mounted lever mechanism</p> 	<p>Breaker mounted mechanism is removed. No levers on the breaker side panels. Needs Spring clip installation in the compartment to achieve rail latch defeat.</p> 
<p>Secondary Disc Bullet mounting</p>	<p>Secondary disconnect bullets mounted on spring loaded bracket assembly</p> 	<p>Secondary disconnect bullets mounted directly on metal bracket</p> 
<p>Kirklock Actuator</p>	<p>Not provided –Kirklock Mechanism (to achieve kirklock feature through existing compartment installed kirklock lever) is not present</p>	

Mechanical Drawings

Below is an AKD-6 mechanical drawing that dimensions the breaker



DWG 3. AKD-6—Retrofill for AKRT-50H –(Model 2 for 2000A & Model 2 for 800-1600A)



AKD-6—Compartment

Interior

Figure 4 displays an empty compartment of the AKD-6 switchgear. Figure 5 shows features of the AKD-6 interior.

Figure 4. AKD-6 Switchgear, Empty Compartment

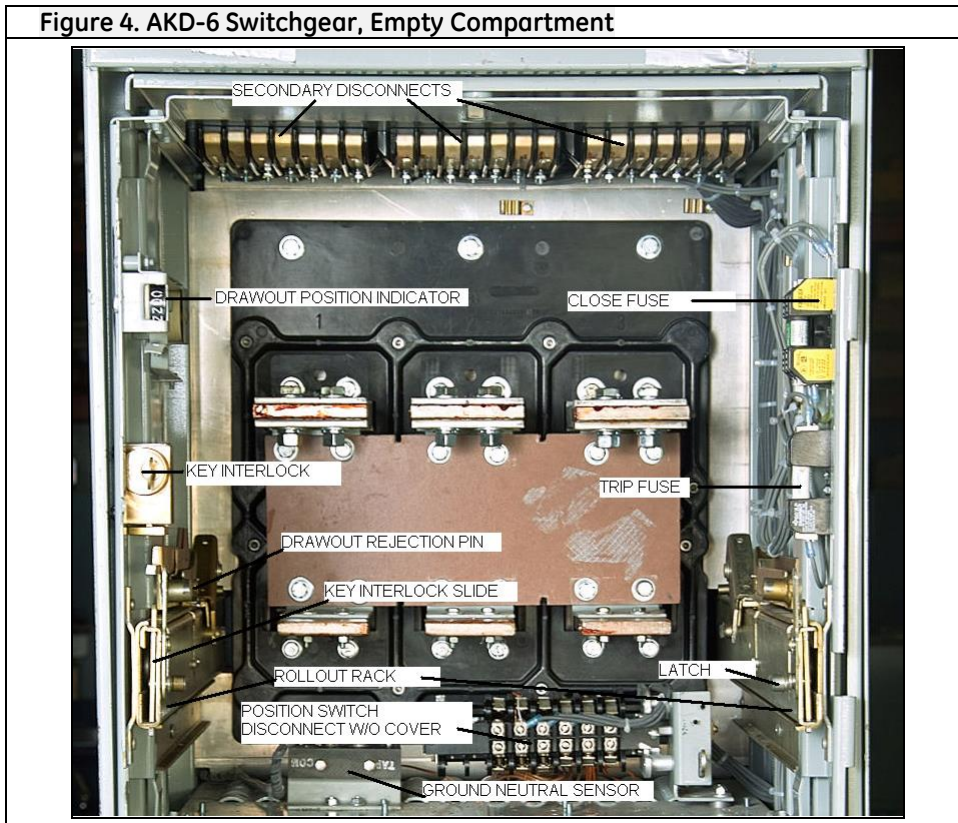
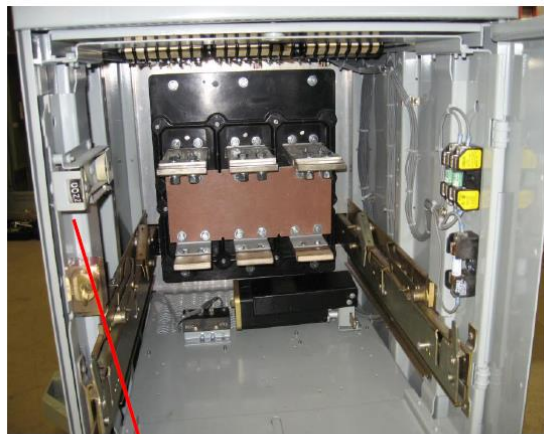
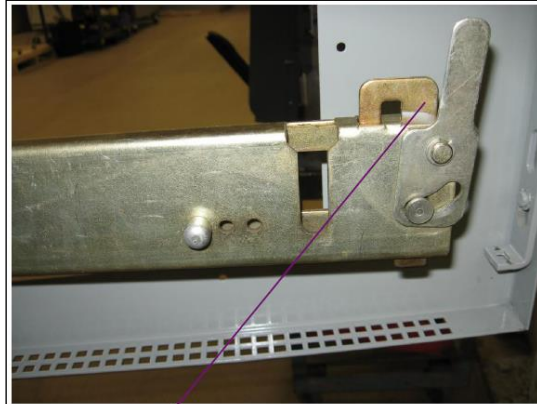


Figure 5. AKD-6 Compartment Distinctions



Indications in compartment



Locking tab for slides

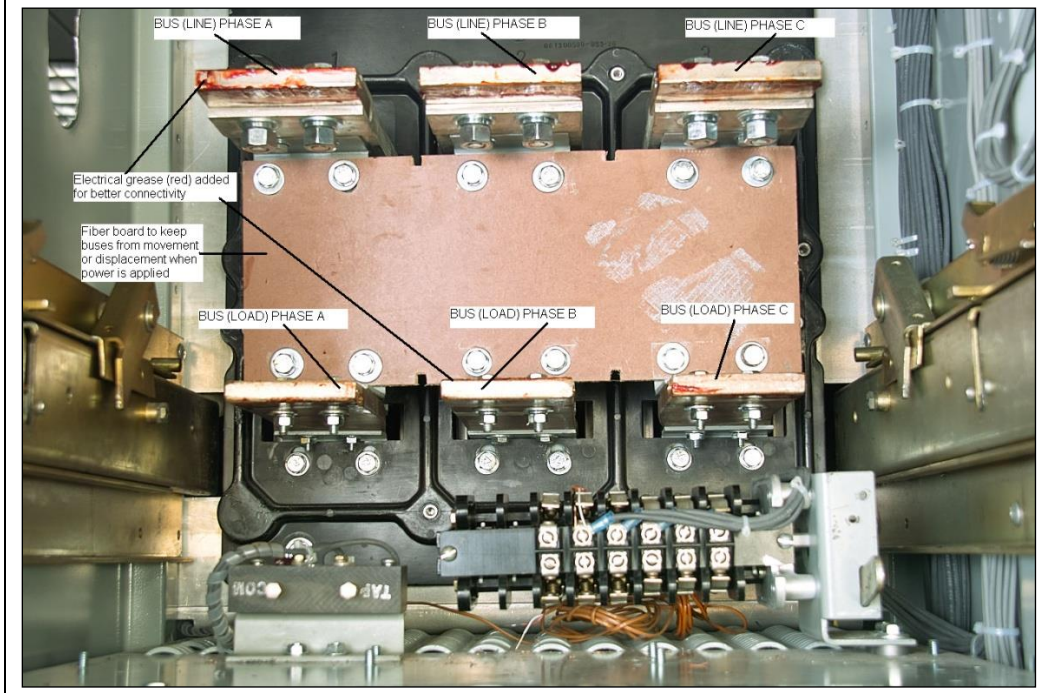
Figure 6 is an example of a compartment in the AKD-6 switchgear that is empty; that is, the upper compartment is ready for a retrofit breaker where the legacy, or original breaker, had been racked out and new wire connections made. The lower compartment has a retrofit breaker, already installed. In this figure, there is also a photo showing a mechanically-operated status indicator (connect/disconnect) that worked with the original breaker. This device, if left in the compartment as is, won't interfere with the retrofit breaker; it can, however, be disassembled by removing its hardware. Figure 7 displays the bus inside the gear.

Figure 6. AKD6 Breaker Compartment (Upper and Lower Compartments)



Status indicator (connect/disconnect) is a leftover device from the legacy breaker. Although it does not interfere with the retrofit, this mechanical indicator can be removed, if desired.

Figure 7. Bus, Interior View



Unpack Retrofill Circuit Breaker

By following the procedures below, you should be able to install the breaker with minimum effort and time.



- Turn off all power to switchgear. Tagout and lockout main source, up-stream or main breaker.
 - Failure to comply with these instructions will result in death or serious injury from severe burns caused by arc flashing that has exceedingly high temperatures.
 - Always wear personal protection equipment according to OSHA standards and appropriate to the severity of potential burns.
-
- Ensure only qualified personnel install, operate, service, and maintain all electrical equipment.



- Do not walk or remain under any heavy assembly while hoisted as the chains securing the assembly may give way

Falling Object

- Ensure lifting equipment has capability for device being lifted.
- Wear hard hat, gloves, and safety shoes.
- Failure to comply with these instructions could result in serious injury.



PRODUCT DAMAGE

- Ensure circuit breaker and its accessories are always used within their designated ratings.
- Do not allow the circuit breaker to hit a hard surface while handling.
- Do not drag or slide the circuit breaker across a hard or rough surface

- A factory-installed rejection feature prevents mismatching circuit breakers and cassettes/substructure, preventing the insertion of a circuit breaker with a lower rating into a higher rated cassette/substructure, or the insertion of a higher rated circuit breaker into a lower rated cassette/substructure.

Quality

All EntelliGuard R circuit breakers have been designed and manufactured to ANSI standards. The design was based on the original requirements from the legacy switchgear and breaker. The product is assembled in Burlington, Iowa; and is inspected using some of the same master gauges used on the legacy AK, AKR breakers to confirm electrical and mechanical performance, including rejections-features.

Information Label

On the side wall of each circuit breaker there is a factory-assembled, label that details all features included on both the circuit breaker and on the trip unit.

Product and Catalog Serial Numbers

Product and catalog serial numbers should be kept handy when communicating about the circuit breaker. Each circuit breaker has a unique serial number located on the left side (viewed from front) of the front fascia.

Remove Circuit Breaker from Container

Inspect


1. Inspect the shipping container for obvious signs of rough handling and/or external damage incurred during transportation.
2. Record any observed damage for reporting to the carrier. Ensure all recorded reports and claims include the order number and name plate information.
3. Remove the banding straps and lift off the top crate cover.
4. Remove all packaging material.
5. Remove all product documentation and store properly.
6. Unscrew the 4 mounting screws that fasten the circuit breaker to the bottom of the shipping palette and remove the circuit breaker.

Use Lifting Truck

1. Use a lifting truck to lift and mount the assembly so that you can avoid personal injury and damaging the breaker.
2. Contact the nearest sales office for availability of a hoisting device.
3. Avoid using hooks and chains since hooks can damage the fascia of the circuit breaker. Lifting bars are available from GE.
 - AKR type Retrofill breakers use the legacy lifting bar (GE Part # 247B8961G002). It is available from GE Burlington, Iowa.


Store Circuit Breaker

If you decide not to install the Retrofill breaker until a later time, then you can store it away for installing it later.

	<p>PRODUCT DAMAGE</p> <ul style="list-style-type: none">• Do not store circuit breaker in corrosive environments above LC1 (sea salt mist) and G1 as per ANSI/ISA-S71.04-1985.• Ensure circuit breakers and cassettes are stored in a clean, dry location, in their original packaging.• Failure to comply with these instructions may result in product damage.
---	---

1. Store the circuit breakers in a clean, dry location in an upright position.
2. Make sure that they are properly supported to prevent bending of the studs or damage to any of the breaker parts. Do not remove any protective grease until they are ready to be installed.
3. If breakers are not to be placed in service at once, remove them from their shipping cartons and thoroughly inspect them for damage.
4. If everything is in satisfactory condition, replace the breakers in their shipping cartons for storage. If it is necessary to store the equipment for any length of time, take the following precautions to prevent corrosion or deterioration:
 - Store in a clean, dry, rodent-free location with moderate temperature and provide protective coverings to prevent dirt, water, or other foreign substances from entering the breaker.
 - If dampness or condensation is encountered in the storage location, heaters can be used to prevent condensation and moisture damage.

Check Before Installing

	<ul style="list-style-type: none">• It must be ensured that the supply power to the compartment is turned off/ compartment is de-energized for all the incoming and outgoing circuits of the LVS prior to any work being conducted on it.• During the installation and related work on the equipment, it must be ensured that the operator is using the prescribed PPE for the specified tasks.
---	--

• Ensure only qualified personnel install, operate, service, and maintain all electrical equipment.

These breakers are supported on a rollout track in the same manner as the AK ,AKR breakers. However, since the Rack-out mechanism is mounted on the breaker, there are no jackshafts in the enclosure. Racking arms on both sides of the breaker frame engage the drawout mechanism pins fastened to both sides of the compartment.

1. Check to see that the breaker or breakers match their respective compartments.
2. Look on the breaker summary sheet, the front view drawings, breaker nameplate, and on the identification card on the breaker shipping carton.
3. To locate the breaker for its proper compartment, refer to the breaker location list on the front view drawing. Find the proper breaker by the identification card on the breaker carton, or the mark number on the breaker nameplate. All identical breakers have the same mark number.

Clean and Grease Breaker

1. Before installing or operating a breaker, refer to the breaker instruction manual for pre-operation inspection and test.
2. Check thoroughly for any damaged or loose parts and for any dirt or foreign matter which may be in the breaker.
3. Clean those areas if necessary with a clean, lint-free rag and isopropyl alcohol or acetone.
4. Be sure to apply a thin film of grease D50HD38 (Mobilgrease 28) to the contact areas of the primary disconnect fingers.

Rack Out Legacy or Existing CB




- It must be ensured that the supply power to the compartment is turned off/ compartment is de-energized for all the incoming and outgoing circuits of the LVS prior to any work being conducted on it.
- During the installation and related work on the equipment, it must be ensured that the operator is using the prescribed PPE for the specified tasks.

- Ensure only qualified personnel install, operate, service, and maintain all electrical equipment.

To rack-out legacy (old or original) breaker from compartment, refer to your legacy-breaker's manual on how to remove the existing breaker.

Install Secondary Disconnect Bullets (Breaker)

	<p>WIRING</p> <ul style="list-style-type: none">• Before installing the breaker, the secondary disconnects must be wired to the EntelliGuard Breaker.• Wires with wire markers are provided on the retrofit. Make sure that the switchgear wiring connection points match up with the original wiring of the cubicle. This ensures that all wiring connections are properly made.• Wrong connections will cause the breaker to malfunction.
---	--

This section deals with the installing and wiring the legacy secondary disconnect assemblies on to the Retrofit EntelliGuard ACB. Installing the secondary-disconnect assembly consists of the following tasks:

- Installation of the secondary disconnect assembly
- Wiring of the secondary disconnect assembly

The Retrofit EntelliGuard ACB has available either of these two options:

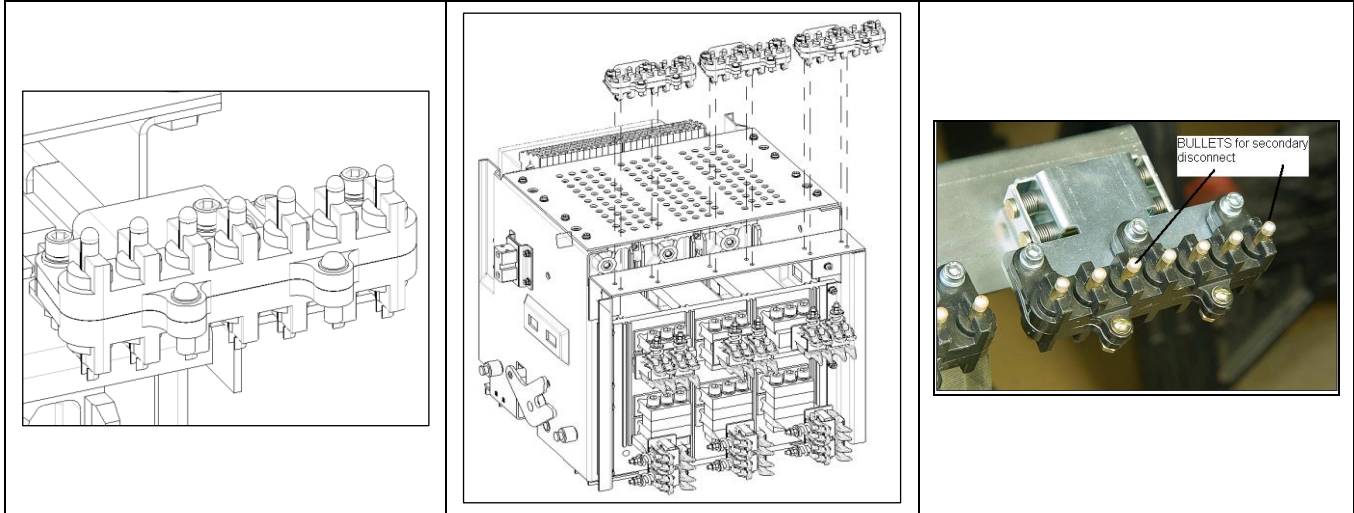
1. All secondary disconnects installed
2. No secondary disconnects installed

If the application requires installing all three secondary disconnect blocks, you would select the first option above. As the secondary disconnects are already pre-installed on the breaker, wiring the secondary disconnects can begin.

If the application does not require any secondary disconnect assemblies, you would select the second option above. This would mean that no further wiring is needed.

If the application requires less than three secondary disconnect blocks, the customer decides on the second option and orders the secondary disconnect blocks (bullets) as needed ([Figure 8](#)). Then the secondaries can be installed and wiring the Retrofit EntelliGuard ACB can be done. Steps for installing and wiring the secondary disconnect bullets are covered in the next section.

Figure 8. EntelliGuard ACB Secondary Disconnect Bullets (Model 1 Breakers)



For Model 1 (800-1600A) AKD6 retrofill breakers

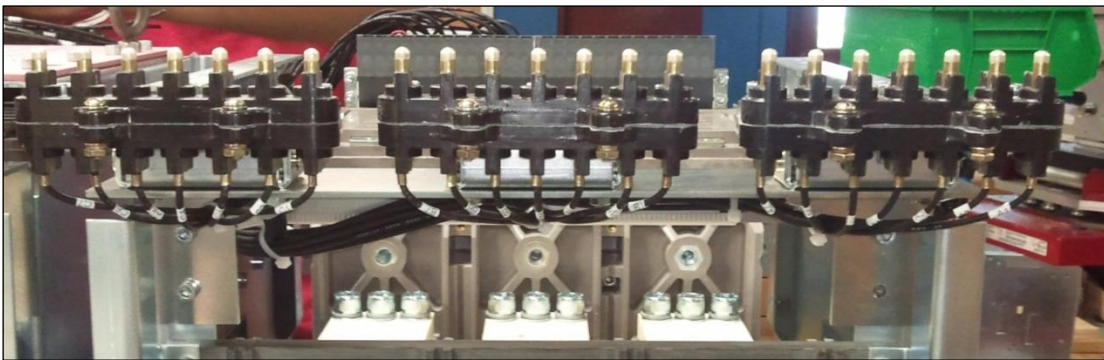
1. Unpack the secondary disconnect block from the box. Each kit of secondary disconnect has four fixing nuts, plain washers, and spring washers. These can be arranged on a work station to prepare for installing the assemblies.
2. Check that the bullets, on top of the secondary disconnects, are not damaged and that they slide in to the blocks freely. The bullets (Figure 9) are spring-loaded and retract to their initial positions when they are released from being pressed down.
3. Check for electrical continuity between the bullets on one and the wire terminations on the other. Blocks containing faulty bullets should be replaced.
4. Place the secondary disconnect block on top of the horizontal plate at the rear of the Retrofill EntelliGuard ACB, which runs across the width of the Retrofill EntelliGuard ACB.
5. Align the four studs at the base of the supplied block to the four holes on the plate. The plate is provided with three sets of four holes, one set for each block (A, B, and C blocks).
6. Slide the secondary blocks down into the plate such that the base of the secondary disconnect rests on top of the plate.
7. Secure the studs on to the fixing plates using the hardware provided as mentioned above. The nuts must be tightened hand-tight.
8. Verify that the wire markers are clearly visible and not damaged so that they are wired easily and efficiently.
9. Be careful that that the wires are not pinched or damaged while installing the secondary disconnect blocks.

For Model 2 AKD6 retrofill breakers

1. If the EntelliGuard R retrofill breaker order included (3) 7 pt. secondary disconnect blocks, see step 2 otherwise skip past the wiring instructions.

2. Check that the bullets, on top of the secondary disconnects, are not damaged and that they slide in to the blocks freely. The bullets are spring-loaded and return to their initial positions when they are released from being pressed down.
3. Check for electrical continuity between the bullets on one end and the wire terminations on the other. Blocks containing faulty bullets should be replaced.
4. Place the secondary disconnect block on top of the horizontal plate at the rear of the Retrofill EntelliGuard ACB, which runs across the width of the Retrofill EntelliGuard ACB.
5. Align the three holes on the face of the supplied secondary block to the three holes on the plate and secure the block to the plates using the hardware provided as mentioned above. The screw tightening torque should be in the range of 77 to 93 in-lbs.

Figure 9. AKD-6—Secondary Disconnects, Bullets



Wire Secondary Disconnect Assembly—AKR30/30H/50/50H

Tools required: wire stripper, wire cutter, and a Philips-head screw driver, M6 wrench

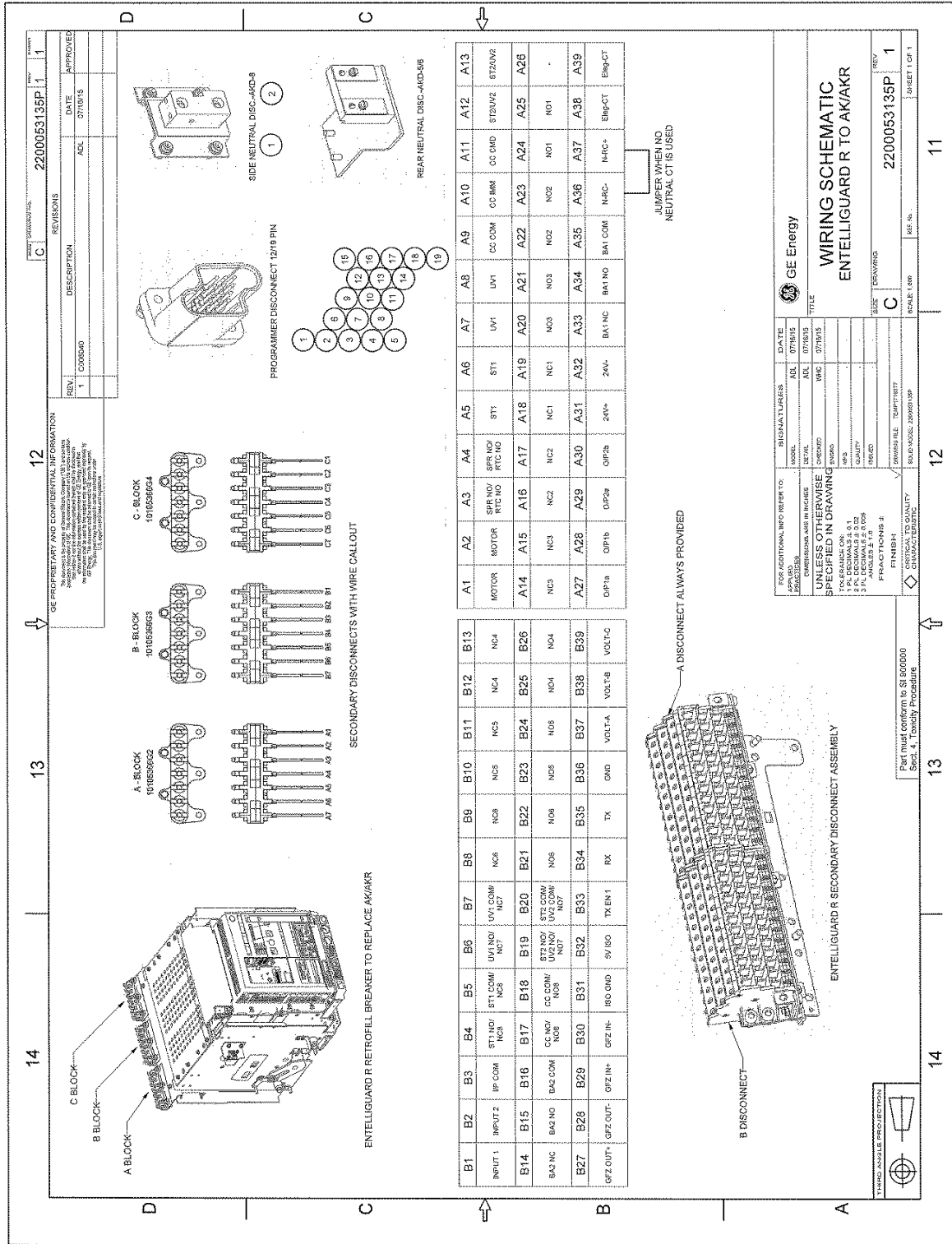
As mentioned above, the secondary disconnect blocks are available with all blocks installed. In this case, the wires on the blocks are routed through one side of the breaker and then on to the front. The wires on the front are left loose for ease of landing them to the EntelliGuard ACB breaker secondary disconnects.

When the secondary disconnect blocks are installed at the customer's site, the wires would not have been already routed. The wires should not be routed from the outside of the metal structure as it might interfere with the motion of the kit during the racking into the compartment. Also, it should be kept in mind that the wires are securely fixed on the inside metal frame of the Retrofill kit with tie-wraps.

Check that wire routing does not exert pressure on the bullets because this can bend the connection points and effects biasing and contact pressure. By using tie-wraps, wire routing can eliminate sagging of the wire harness and undue pressure on secondary bullets.

Once the above mentioned steps are completed, landing the wires to the points on the EntelliGuard ACB secondaries can begin.

Figure 10. Typical AKD-6 Wiring Diagram



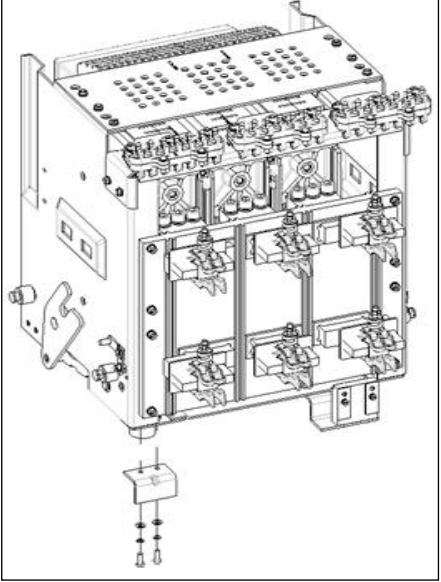
Installing Position Switch Actuator (Breaker)

Note: Later models of breakers (Q3 2015) are shipped with position switch bracket pre-installed.

Position switch actuator bracket can be installed on all versions of Retrofill EntelliGuard ACB for AKD6 LVS ([Figure 10](#)). The steps of installation are as follows:

Retrofills use the legacy position switch already mounted in the cubicle. If a new position switch has to be installed, refer to the legacy position switch installation manual.

1. Unpack the position switch bracket. Each bracket is provided with a pair of M6x16mm Allen-type bolts and washers.
2. Place the bracket on the bottom right side of the AKD6 base. Two locating holes are provided for mounting of the position switch bracket.
3. Fasten the two bolts to the locating holes after placing the washers to securely mount the bracket.
4. The bracket is ready for use.

Figure 10. AKD-6—Position Switch Actuator (Breaker Side) and Parts				
Level	Item or Part Number	Description	Quantity	
1	10105289P1	Position Switch Brkt, AKD-6	1	
1	10100950P4	Washer M6	2	
1	10100380P1	Serrated Belleville Washer M6	2	
1	10100545P1	Cap Head Screw M6x16	2	

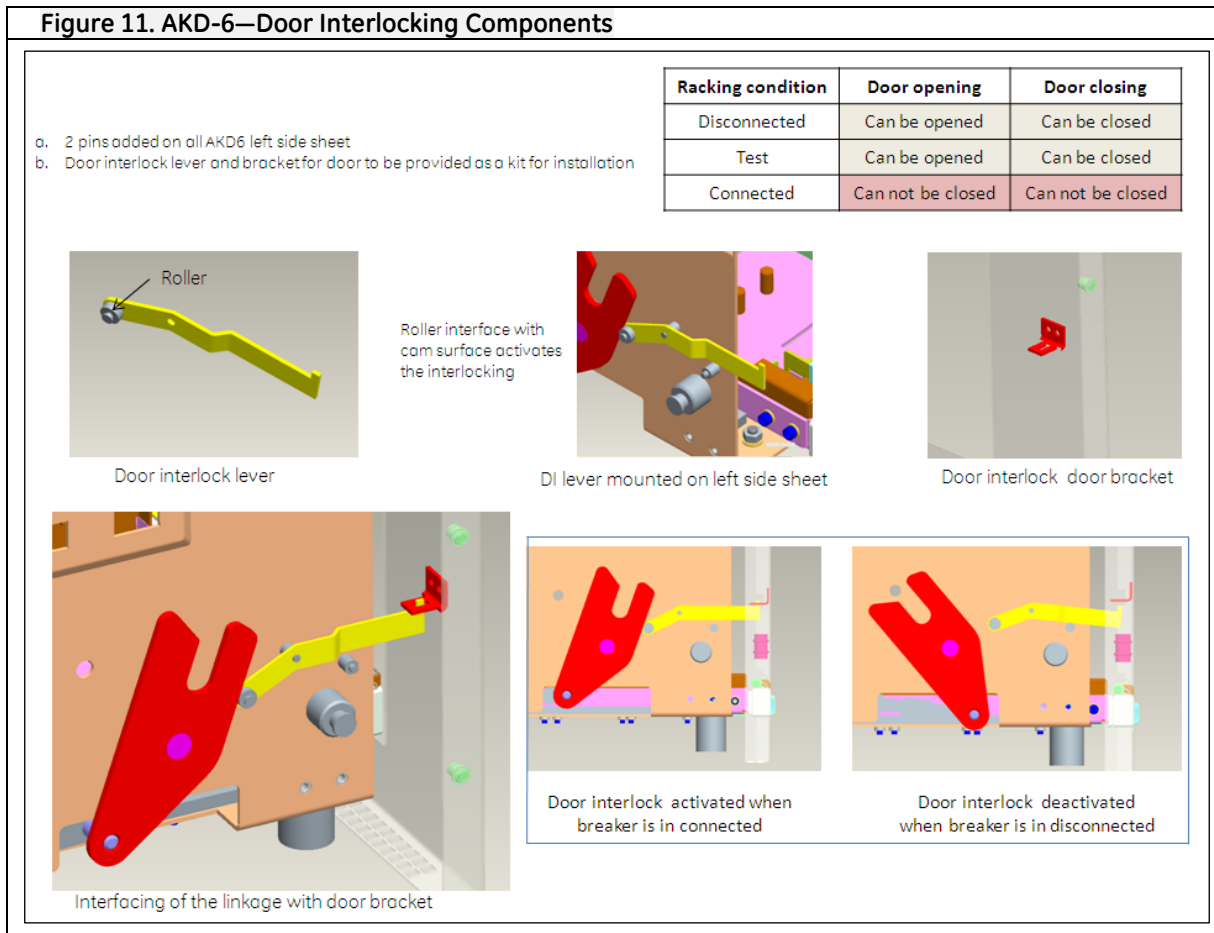
Note: Individual hardware for the position switch actuator cannot be ordered separately. The item numbers given are for reference only. The assembly comes as a unit or a kit.

Installing Door Interlock System (Breaker)

P/N 10108779G1 Door Interlock Kit

Tools required: Flat screw driver, E-clip mounting tool

The door interlock system prevents opening of the breaker compartment door when the breaker is in the racked-in position and connected state. [Figure 11](#) shows the components that make up the AKD-6 retrofill door interlocking assembly.



The sequence of assembly steps of the door interlock is as follows:

1. Unpack the door interlock kit. Each kit consists of a torsion spring, two E-clips and a breaker side-door interlock bracket.
2. Place the torsion spring on the pin as shown in the exploded view below and anchor it by placing one end of the pin into the hole provided inside the side-sheet of the retrofill.
3. Mount the door interlock bracket on the same pin via the hole provided on the bracket. Also, it must be ensured that the slot of the door interlock bracket is mounted on the second pin, placed on the front as shown in [Figure 12](#).
4. Mount the free end of the torsion spring on the bracket as shown [Figure 13](#).
5. Insert the E-clips mentioned in [Step 1](#) to complete the assembly.

Figure 12. Mounting the Door Interlock Bracket

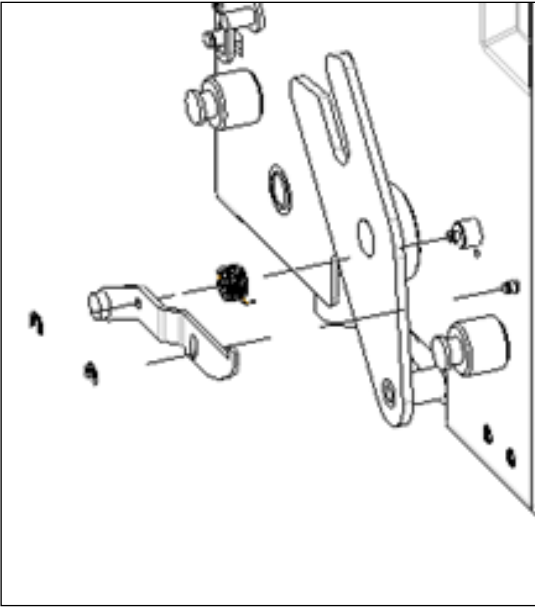
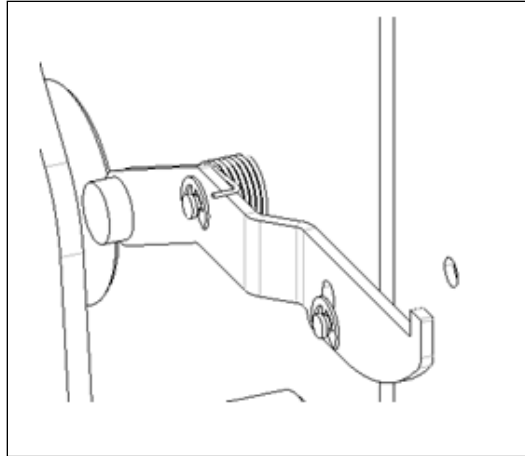
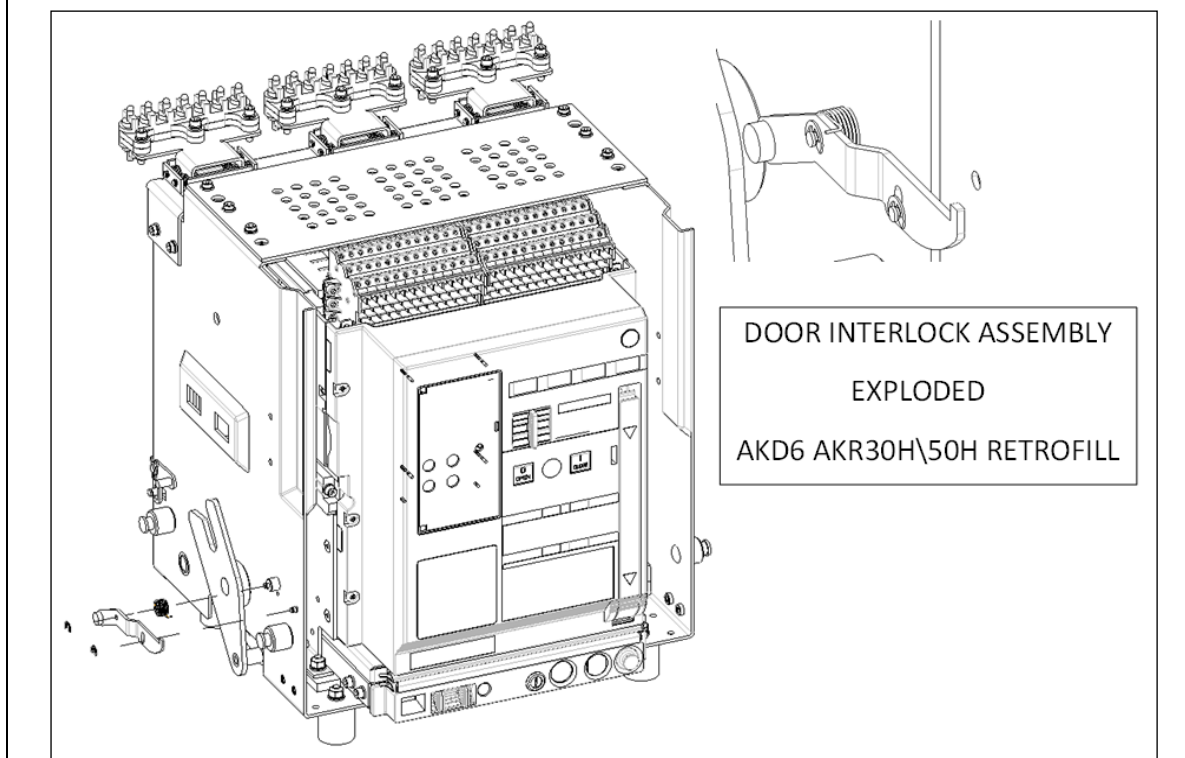


Figure 13. Torsion Spring for Door Interlock Bracket



The completed assembly of the door interlock will be as shown below (Figure 14).

Figure 14. AKD-6 AKR30H/50H Door Interlock Assembly (exploded view)



P/N 10108779G1

Door Interlock Kit

AKD6

AKD-6 Key Interlock

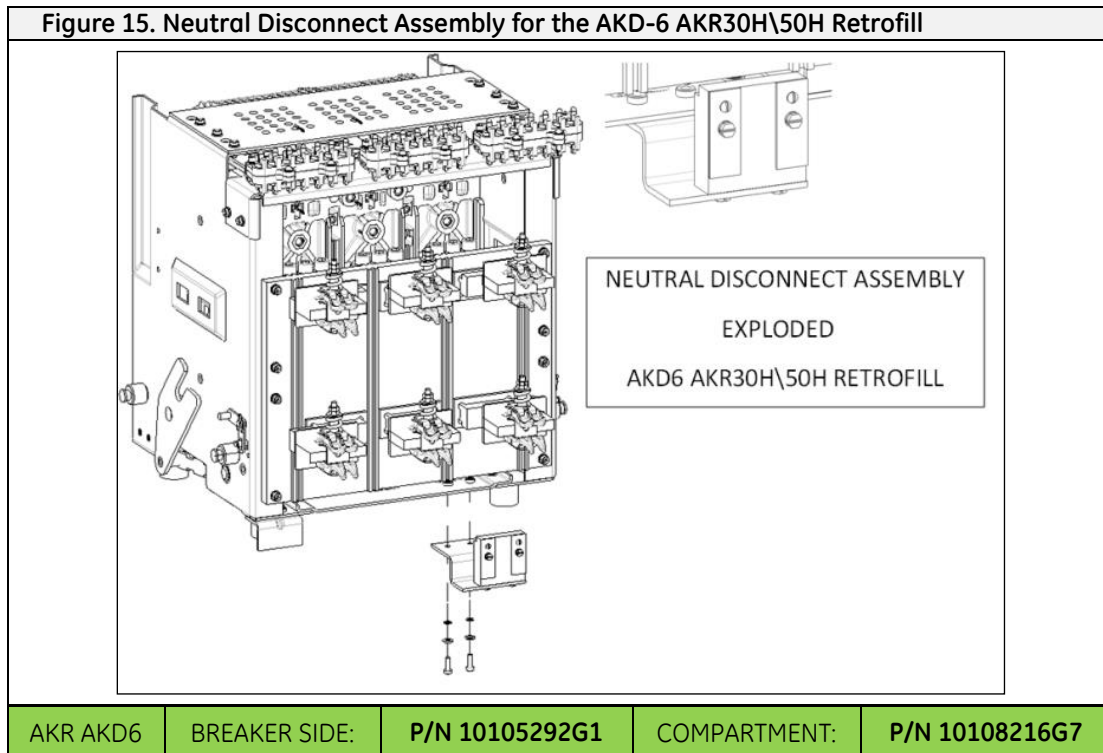
The EntelliGuard R retrofit circuit breakers provided as replacements for AKR 800-2000A frame circuit breakers have a trip interlock feature which will function using the AKD-6 compartment mounted Key Interlock. A label is provided with full instructions on how to operate the Legacy Key Interlock. It is suggested to apply the label on the inside of the compartment door. Following is a brief summary of how the Key Interlock system is operated.

To activate the key interlock:

- 1) OPEN the breaker.
- 2) Rotate the screw on the lower front panel of the breaker which normally allows access to the racking screw. This will hold the breaker trip free.
- 3) While the screw is held rotated Clockwise, the Key Interlock slide in the switchgear is pushed inward, elevating a pin on the left side of the breaker.
- 4) Turn the key to the key removal position, extending the bolt and lock the breaker in the OPEN position.

Installing Neutral Disconnect Assembly (Breaker)

Figure 15 shows an exploded view of the breaker side neutral disconnect assembly for the AKD-6 AKR30/30H/50/50H retrofills. These will be available preinstalled and wired from the factory.



19-Pin Programmer Secondary Disconnect (Breaker)

The 19-pin programmer disconnects can now be included with the AKD-6 series retrofills to accommodate the extended features of the EntelliGuard Trip Unit. The 19-pin programmer-disconnect assemblies already come pre-installed and wired from the factory and do not require any installation in the field.

The compartment side is installed and wired in the field by a qualified electrician or installation service company.

[Figure 16](#) shows the 19-pin programmer-disconnect on the AKR30/50, bottom side of the breaker, already installed. [Figure 17](#) displays the wiring diagram for the programmer-disconnect (12-pin and 19-pin combined in one diagram, although the AKD-6 does not use the 12-pin). [Figure 18](#) features an exploded view of the 19-pin programmer disconnect. An installed view of the 19-pin programmer disconnect appears in [Figure 19](#). For the compartment side, the 19-pin is ordered separately and comes in a box. Below are the part numbers for the breaker and compartment 19-pin programmer-disconnect assemblies.

BREAKER SIDE	P/N 10107108G1	19-PIN PROGRAMMER DISC ASSY	AKD6
COMPARTMENT SIDE	P/N 10106652G1	19-PIN PROGRAMMER DISC ASSY	AKD6

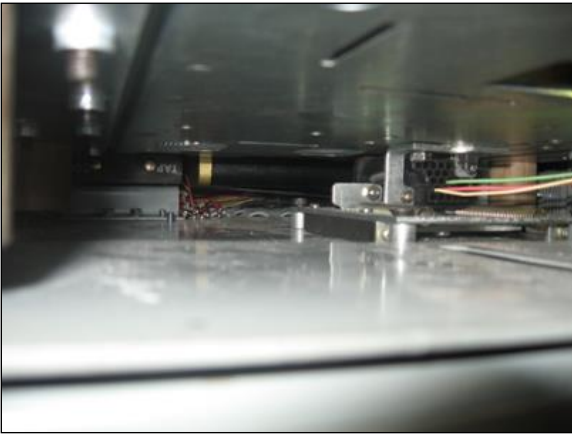
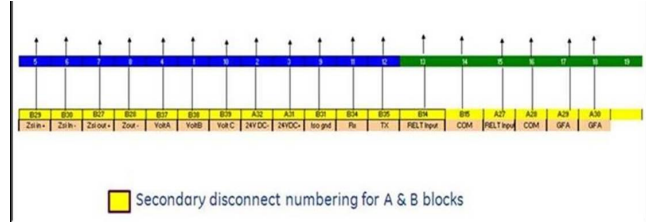
<p>Figure 16. 19-Pin Programmer Disconnect on the AKR30/50 Breaker</p>	<p>Figure 17. Wiring for Programmer Disconnect (19-Pin) –magnified view on page 29</p>
	 <p>Secondary disconnect numbering for A & B blocks</p>

Figure 18. 19-Pin Programmer Disconnect for the AKD-6 AKR30H\50H Retrofill, Exploded View

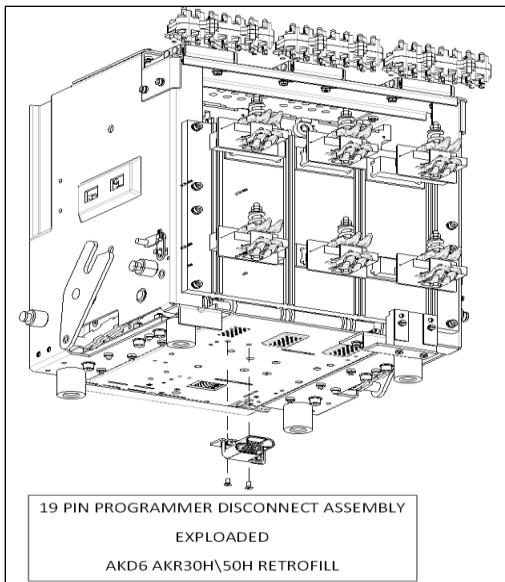


Figure 19. 19-Pin Programmer Disconnect AKD-6 AKR30H\50H Retrofill, Installed

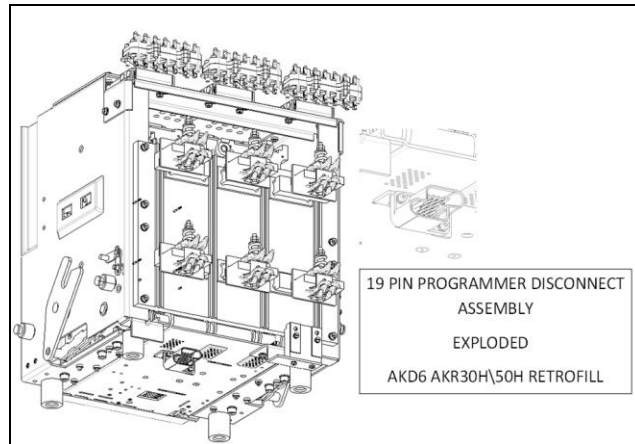
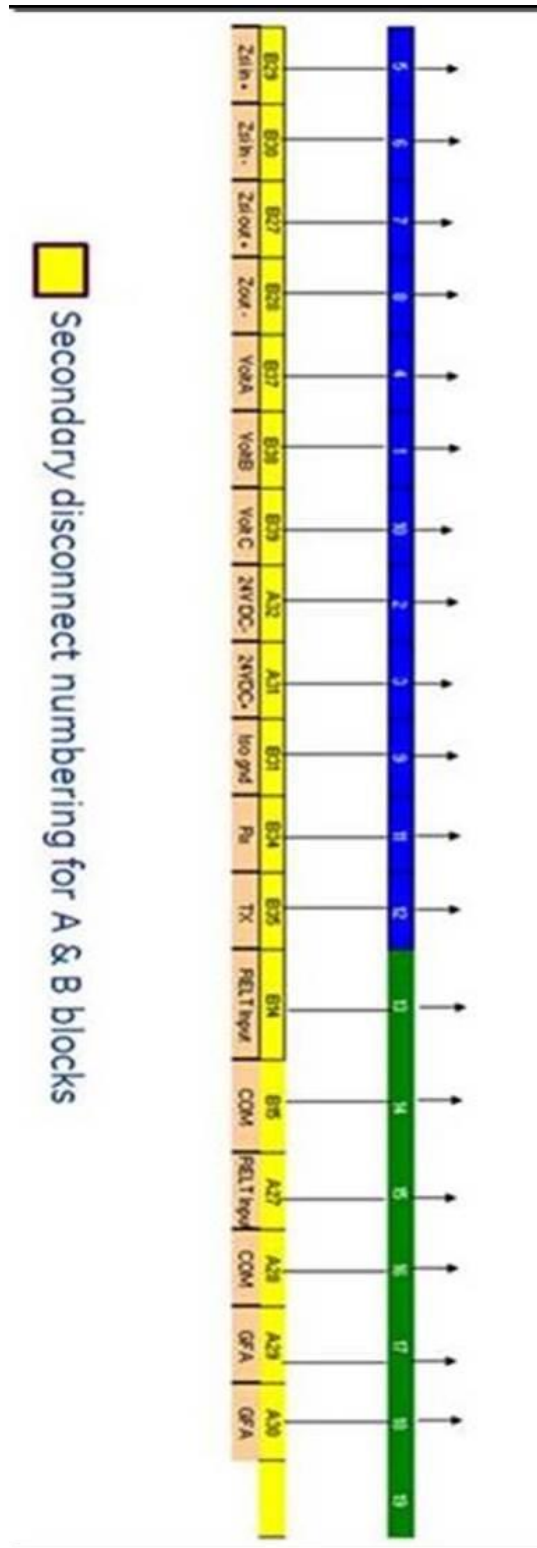


Figure 20. Wiring for Programmer Disconnect (19-Pin)



Installing AKD-6 Retrofill Circuit Breaker



- It must be ensured that the supply power to the compartment is turned off/ compartment is de-energized for all the incoming and outgoing circuits of the LVS prior to any work being conducted on it.
 - During the installation and related work on the equipment, it must be ensured that the operator is using the prescribed PPE for the specified tasks.
- Ensure only qualified personnel install, operate, service, and maintain all electrical equipment.

Breaker Installation Overview:

Note: While installing the breaker, if the AKD-5/ AKD-6 inner housing & front door assembly move inward more than a couple inches from the fully Disconnected position, before the breaker and moveable rails are pushed in and front rail latches are toggled; then interlocks at the compartment rear will block movement of the sliding rails & breaker.

Model 1 800-1600A EntelliGuard R Retrofill Breakers

If the AKD-6 compartment is in working condition; levers on either side of the compartment will lock against welded tabs and keep the inner housing & door assembly latched in the fully Disconnected position (as shown on original indicator tape in AKD-6) while the breaker and sliding rails are pushed in and front rail levers are toggled. The original AKR-30/50 style breaker would then unlatched the two levers by motion of the racking cams as it began its 4.25" Drawout travel. The EntelliGuard R retrofill breaker has a 2.5" drawout travel. The model 1 design assumes a fully working compartment. After loading the new breaker and sliding the rails fully inward; the rail levers are toggled as usual. Then it is necessary to pull out and hold a plastic padlocking type slide (Figure 24) which in turn moves two Rail Latch Defeat Levers (see Breaker Model Comparison Table). With the compartment rail latches defeated, the breaker & inner housing can be pushed inward until the new breaker's racking cams engage the compartment racking pins. Then the door can be closed and the breaker can be racked in normally. See details below "For Model 1 Retrofill Breaker".

Model 2 design for 800-1600A & all 2000A EntelliGuard R Retrofill Breakers (Q3 2015)

The rail latch defeat Levers found on the on model 1 breakers and shown in Breaker Model Comparison Table were eliminated for two reasons.

- 1) To make space for mechanical parts added to allow the original AKD-6 compartment mounted key interlock to function with the retrofill circuit breaker.
- 2) The AKD-6 locking levers were often damaged and not working to hold the inner compartment housing and door assembly in the Disconnect position (as shown on the original indicator tape in AKD-6), while sliding the breaker into the switchgear.

Note 1: In the model 2 design, two spring clips are given for installation in the compartment to permanently defeat the AKD-6 compartment locking levers. Two tools are given to block motion of the inner housing and door assembly. See Figures 27 & 28.

Note 2: The two tools are stored inboard on each steel side frame of the breaker, hung on a key slot arrangement.

Note 3: The model 2 breaker loading system: spring clips and tools can be used on a model 1 breaker if the AKD-6 compartment levers are damaged.

Install or Insert AKD-6 Retrofill

After the existing breaker is removed and the retrofill breaker is wired to match the compartment, it can be installed in the AKD-6 switchgear.

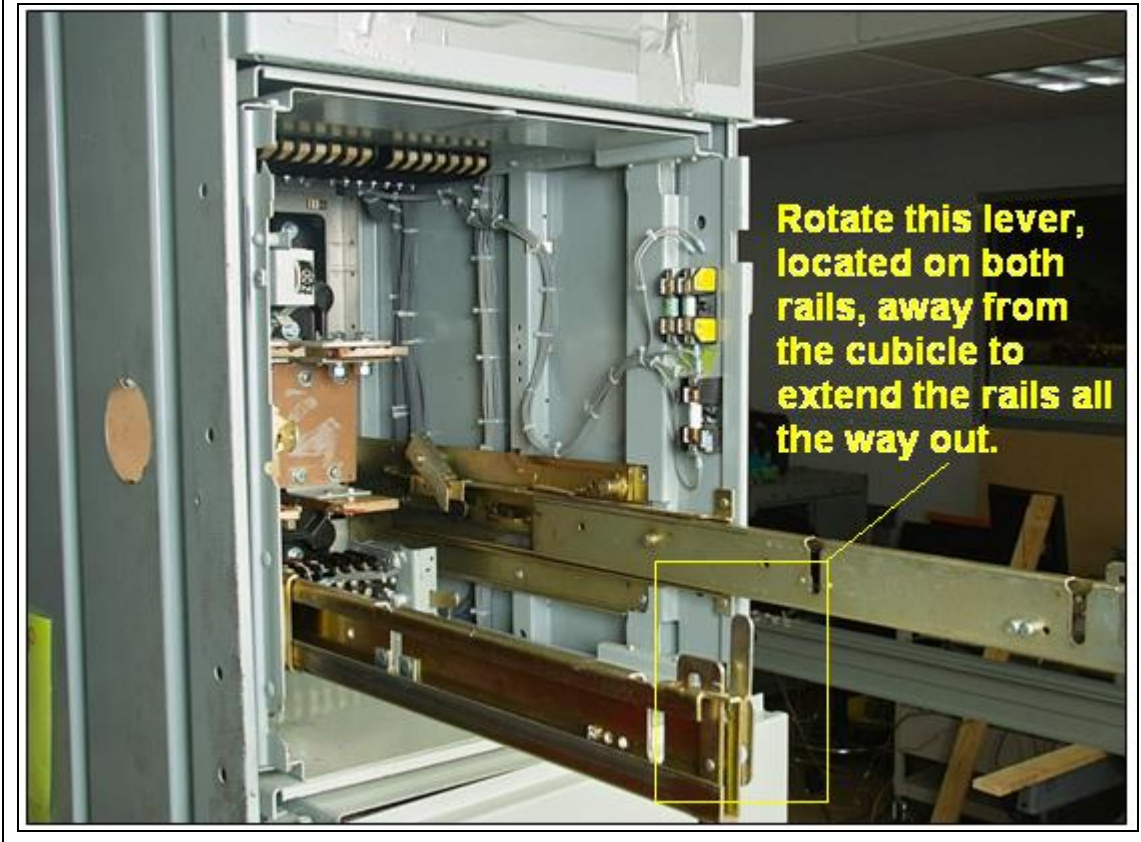
1. Verify the retrofill breaker model type with the help of model identification table provided in the previous section 'History & Types'
2. Verify that the breaker is in the disconnected, switched-off position before mounting it on the rails.

For Model 1 Retrofill Breaker (Refer to AKD6 Breaker Model comparison table for model identification)

Applicable for R2 800-1600A model 1 only

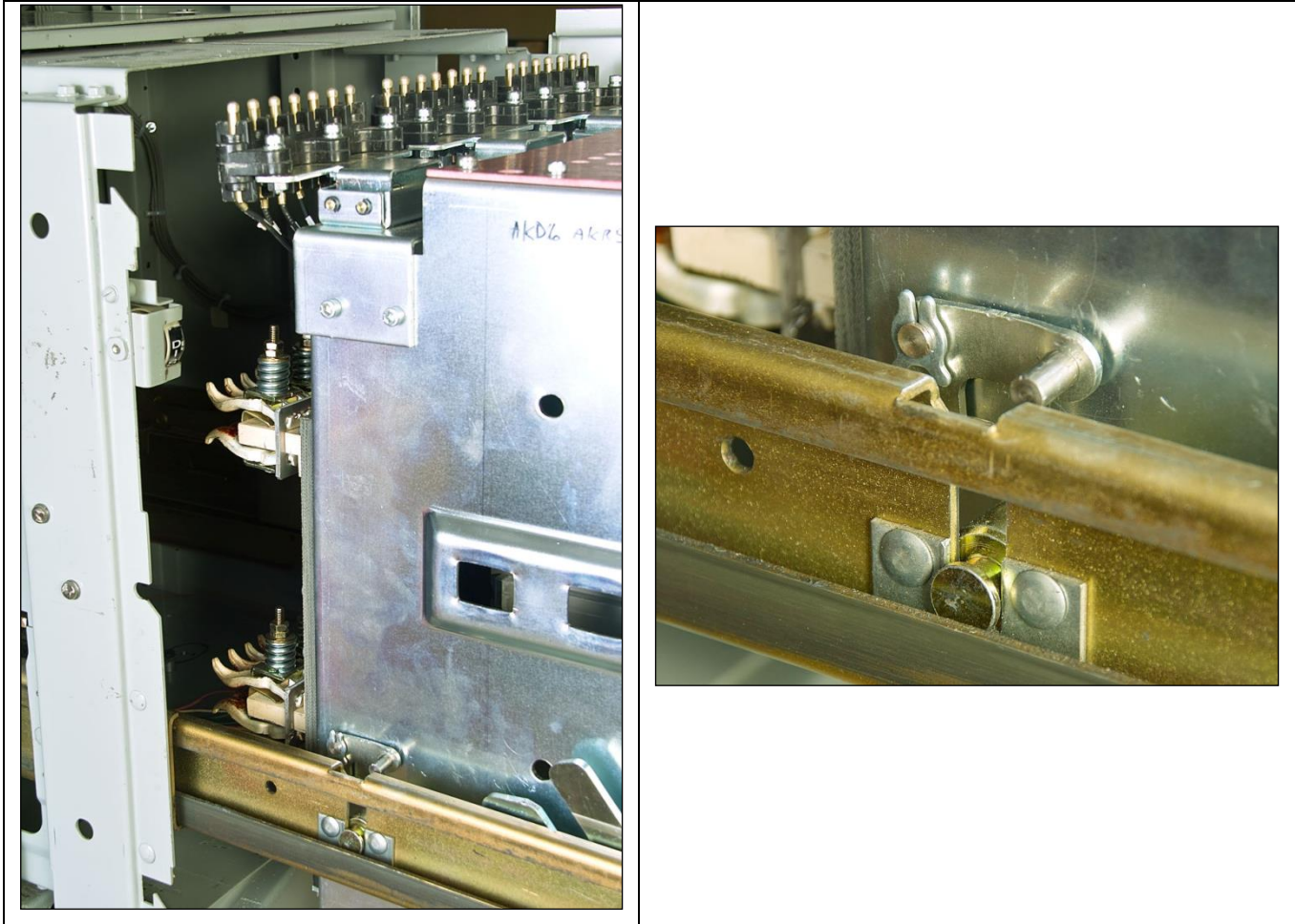
1. While rotating the lever (away from the cubicle) at the end of each rail, which unlocks the inner rail, pull both the rail assemblies outwards to their fully extended positions.
2. The entire inner housing and front door must also be extended fully outward ~ 4.5" such that both rail latches can engage with the welded tabs. (see fig. 27)

Figure 21. AKD-6 Rails or Arms for Mounting Retrofill Cassette/CB



3. Use a suitable lifting device and AKR lifting bar. This might require a two-man effort: one to carefully and slowly operate the lift and the other to guide the breaker into the switchgear rail slots.
4. Make sure that the lifting bar is secured and locked in place on the breaker.
5. Check that the retrofill is free from obstruction inside the compartment.
6. When the breaker is lined up with the compartment, raise the breaker only slightly higher than the compartment floor, keeping it at slight angle.
7. Keep the breaker steady. Continue to guide the breaker, while checking both sides and underneath, so that both sets of pins can be lowered and lined up easily with the rails slots.
8. Place retrofit EntelliGuard R Retrofill breaker on the rails (fig. 22) to the disconnect position of the legacy breaker. (Note that the pins must line up with the slots on the rails.)
9. Once the breaker rests on the rails at all 4 pins, unhook the lifting bar and move the hoisting apparatus out of the way.

Figure 22. Retrofill Hoisted and Secured on Rails (model 1)



- 10.** Push the breaker into the compartment until it can't be pushed in any further and toggle the rail levers to latch the inner rail with outer rail.
- 11.** Pull the shutter pad lock lever to defeat the latch on the rail (fig. 24).(Model 1 only)
- 12.** Put a of 3/8" dia rod in the hole of the shutter padlock lever (fig. 24).Push the retrofill breaker to "test" position of the legacy breaker. This will be the disconnect position for the retrofill breaker.
- 13.** Remove the rod from the shutter padlock lever and allow the lever to go back.
- 14.** Note: Now the new retrofill breaker can be racked in, using the racking mechanism provided in the breaker.

Figure 23. Latching Inner Rail with Outer Rail

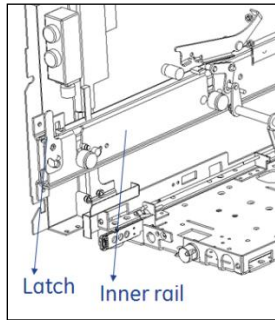
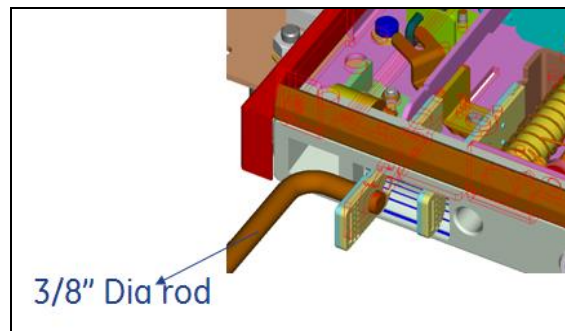


Figure 24. Inserting Rod



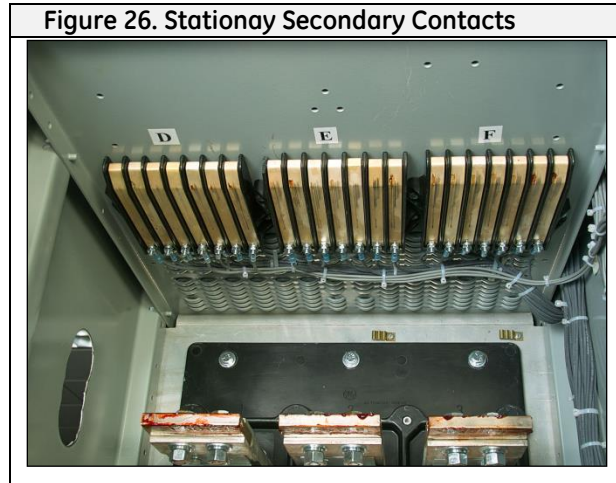
15. Remove the racking tool from the storage location on the retrofill front panel and grab the handle and extend the torque bar from inside the handle.
16. Use a blade-type screwdriver in the slot or rack-out lock of the breaker (fig. 25) and turn it clockwise 45° to the right so that the racking handle shutter.

Figure 25. Racking in AKD6—Retrofill



17. While turning the screwdriver to the right with the racking tool shutter open, insert the racking tool in the handle-insertion hole, so that it engages the racking mechanism inside the hole.
18. Line up the racking tool or crank with the handle straight up so that you can get some good leverage or torque. Then, crank clockwise so that the retrofill starts to move in, slowly sliding forward into the compartment. Push the breaker in slightly to engage racking cams, if torque seems high at the start.
19. Rotating clockwise ~37 turns racks the circuit breaker all the way into the enclosure.
20. As the breaker approaches the TEST position, check the alignment of the fixed and moving parts of the secondary disconnect contacts (fig. 26). If a motor spring-charge or under-voltage-release is installed, these devices might activate when approaching the TEST position.

21.



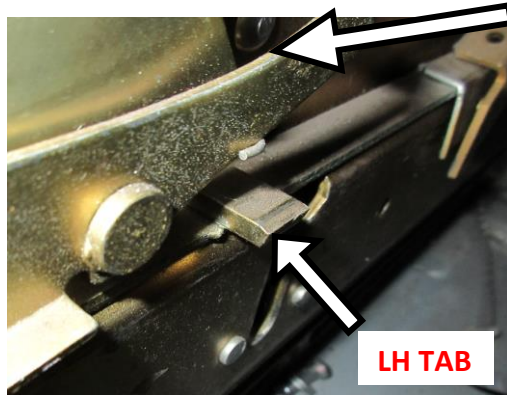
22. Continue rotating the racking handle clockwise until the position indicator first shows TEST, and then finally shows CONNECTED.
23. When approaching the CONNECTED position, more torque for turning the racking handle is normal as the primary finger clusters engage with AKD6 primary bus stabs.
24. Keep cranking as required, that is, when any further torqueing can't be done.
25. At 37 clockwise rotations, the fingers at the back of the circuit breaker should be completely engaged with the primary bust stabs.
26. Remove and store the racking handle in it storage location.

For Model 2 Retrofill Breaker (800-1600A) and Model 1 (2000A) Retrofill

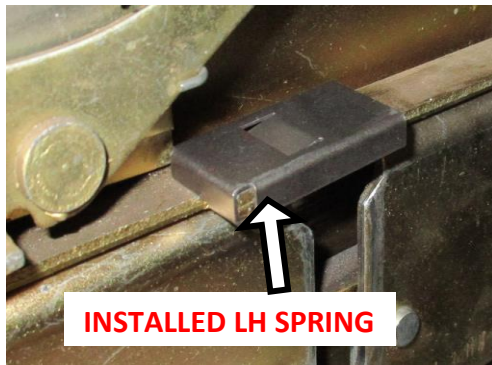
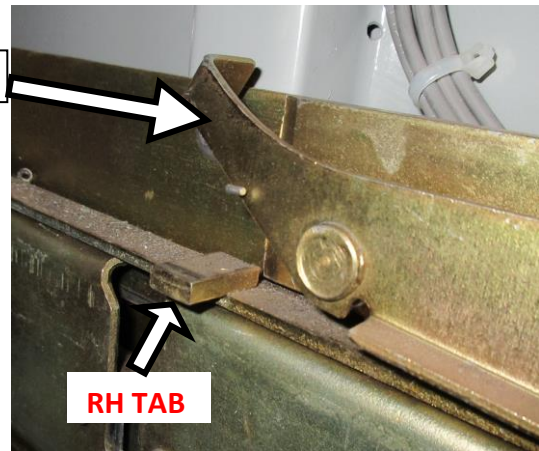
1. Install Spring Clip , RH (2200123529P) on right hand side stationary rail tab & Spring Clip , LH (2200123530P) on left hand side stationary rail tab by sliding the clip until a 'click' is heard. Once installed, clip cannot be removed. These clips permanently defeat the rail latches. Fig. 27 shows tabs before and after installing a spring clip.
2. Follow the procedure steps from 1 to 9 described above for installing Model 1 retrofill breaker.

Figure 27. AKD-6 Stationary rail Tabs for Mounting Spring clips (for Model 2 Breakers)

LH side Stationary Rail



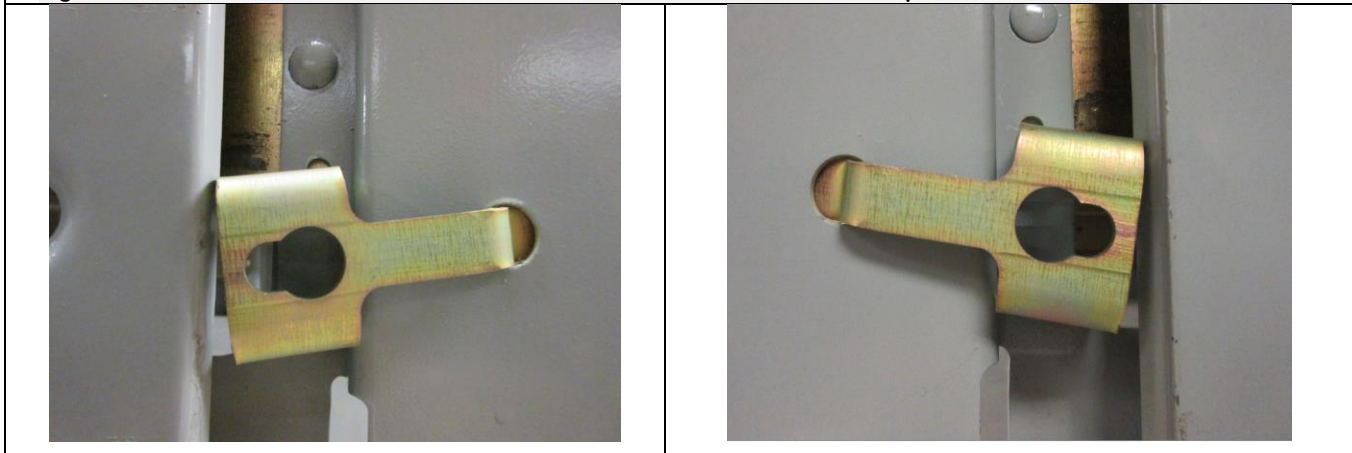
RH side Stationary Rail



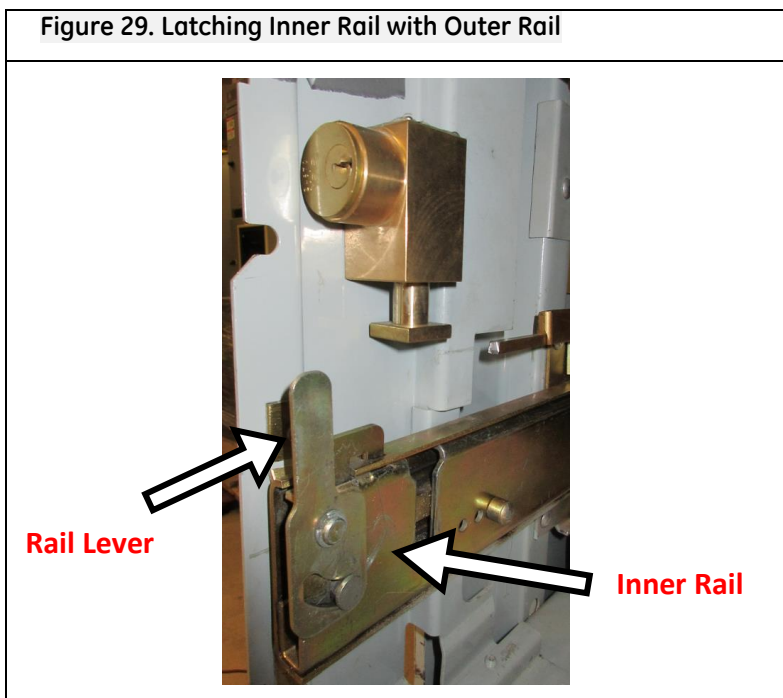
SPRING CLIP INSTALLATION KIT GE PART # 2200053286A

3. Install breaker installation tools on both sides of the sliding compartment door box as shown below. Two (2) tools are provided along with each Model 2 breaker. (fig. 28)

Figure 28. Breaker Installation Tool (2200045171P) mounted on AKD-6 compartment sides (LH & RH)



4. Push the breaker into the compartment until it hits the first complete stop due to installed breaker installation tools (fig 28).
5. Push the breaker and sliding rails fully into the compartment.
6. Latch the inner rail with outer rail (fig. 29) by rotating the rail lever
7. Remove and store two (2) installation tools.
8. Now the new retrofit breaker can be racked in, using the racking mechanism provided in the breaker.
9. Follow the procedure steps from 15 to 25 as described for installing Model 1 retrofit breaker



Remove and Replace Existing Door



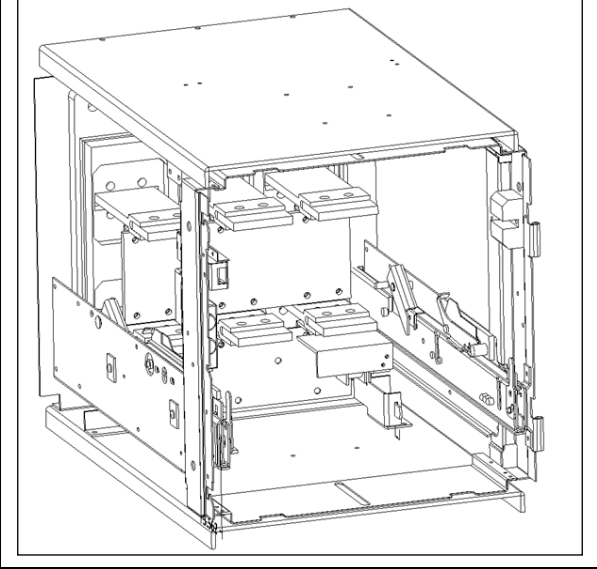
- It must be ensured that the supply power to the compartment is turned off/ compartment is de-energized for all the incoming and outgoing circuits of the LVS prior to any work being conducted on it.
 - During the installation and related work on the equipment, it must be ensured that the operator is using the prescribed PPE for the specified tasks.
- **Ensure only qualified personnel install, operate, service, and maintain all electrical equipment.**
1. To remove existing compartment door(s), refer to your manual on how to remove the legacy doors.
 2. To install new door, refer to the [Retrofit Door Assemblies, DEH-41563](#).

Prepare Switchgear Compartment



- Ensure the circuit breaker has been tripped, indicating OFF, and the main springs are fully discharged.
 - Do not touch the circuit breaker's isolating contacts during lifting
 - Failure to comply with these instructions could result in death or serious injury.
- **Ensure only qualified personnel install, operate, service, and maintain all electrical equipment.**
1. Before modifying the switchgear compartment, de-energize/switch off the breaker. If the circuit breaker is ON and the springs are charged, to turn it off, press the OPEN button on the circuit breaker fascia, and ensure that the circuit breaker contacts are open.
 2. Inspect the compartment for damage, rework ([Figure 30](#)).

Figure 30. Prepare AKD-6—Compartment



3. Check cabinet for suitability of retrofill.
4. Check each breaker compartment for bolted joints in the primary disconnect bars. Where such joints exist, check the bolts for tightness.
5. Inside the compartment, check the contact areas on each primary disconnect bar or cluster of fingers for foreign matter that may have accumulated. Clean those areas if necessary with a clean, lint-free rag and isopropyl alcohol or acetone.
6. Be sure to apply a thin film of D50HD38 (Mobilgrease 28) to the contact areas for better electrical connections inside the compartment.

Install Neutral CT Assembly (Bus Compartment)



- It must be ensured that the supply power to the compartment is turned off/ compartment is de-energized for all the incoming and outgoing circuits of the LVS prior to any work being conducted on it.
- During the installation and related work on the equipment, it must be ensured that the operator is using the prescribed PPE for the specified tasks.

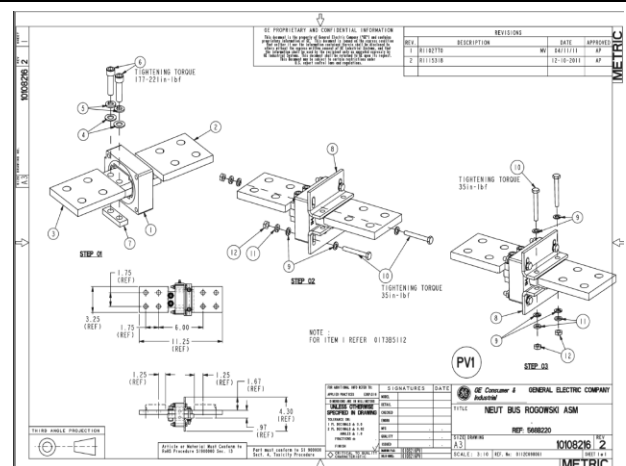
- Ensure only qualified personnel install, operate, service, and maintain all electrical equipment.

The AKD-6 EntelliGuard R Circuit Breaker uses an air-core Rogowski Current sensor to measure current level vs. an iron core CTs used in the legacy AK, AKR breakers. For the Retrofill to calculate the current levels on a 4-wire circuit, the Neutral Iron Core CT in the cable compartment needs to be replaced with a Rogowski style CT (*Figure 31*). Consult the table for the appropriate Rogowski assembly for the switchgear (*Table 7*).

The Rogowski CT comes mounted on copper bars matching the same hole-pattern as the existing neutral bar. The external neutral Rogowski mounting kit comes with three mounting brackets, two fixing screws, two cable ties, one 2m (78.75 inches) long twisted pair extension lead and one neutral Rogowski coil.

Breaker/Switchgear	Rogowski Assembly or Neutral Bus Bar Part Numbers
AKD6 400A	10108216G1
AKD6 600A	10108216G2
AKD6 800A	10108216G3
AKD6 1000A	10108216G4
AKD6 1200A	10108216G5
AKD6 1600A	10108216G6
AKD6 2000A	10108216G7

Figure 31. Neutral Bus Rogowski ASM 10108216



1. Be sure that the LVS has been de-energized and the breaker in the compartment being retrofit are switched off and removed from the LVS.
2. Open the door on the rear of the compartment to gain access the cable/bus compartment of the LVS.
3. The existing neutral CT assemblies are usually mounted vertically on two copper bus bars placed horizontally.

4. Disconnect the wires that are attached to the existing CT assemblies and place them so that they do not interfere with the replacement of the CT assemblies.
5. Unfasten and remove the bolts holding the neutral disconnect assemblies to the horizontal bus bars. Keep the hardware in a secure location for reassembly.
6. Care should be taken while handling the CT assemblies so that they do not fall down or damage other components within the LVS.
7. Replace the old CT assembly by the new Rogowski assembly on the horizontal bus bars and fasten it using the hardware previously removed.
8. Connect the wires back to the Rogowski CT assembly leads. In case of damaged wires, the same must be replaced with new ones as already mentioned.
9. Check for continuity from the CT leads to the plungers on the neutral-disconnect assemblies within the LVS compartment.
10. The new Rogowski assemblies are installed and ready for use.

Tools required: Wrenches, Wire stripper, wire cutter, continuity tester.

Multi-Source Ground Fault

Retrofills can be used in the following ground fault applications:

- Single Source Feeder breakers, 3 wire or 4 wire
- Main Circuit breakers, 3 wire or 4 wire

When multi-sources are present with the ground fault detection on the trip unit desired, then an external GF summing CT scheme must be implemented. This applies to main—tie—main systems or systems with a main source and then a back-fed generator source.

Consult factory for MSGF configurations.

Install 19-Pin Programmer Secondary Disconnect (Compartment)



- It must be ensured that the supply power to the compartment is turned off/ compartment is de-energized for all the incoming and outgoing circuits of the LVS prior to any work being conducted on it.
- During the installation and related work on the equipment, it must be ensured that the operator is using the prescribed PPE for the specified tasks.

- **Ensure only qualified personnel install, operate, service, and maintain all electrical equipment.**

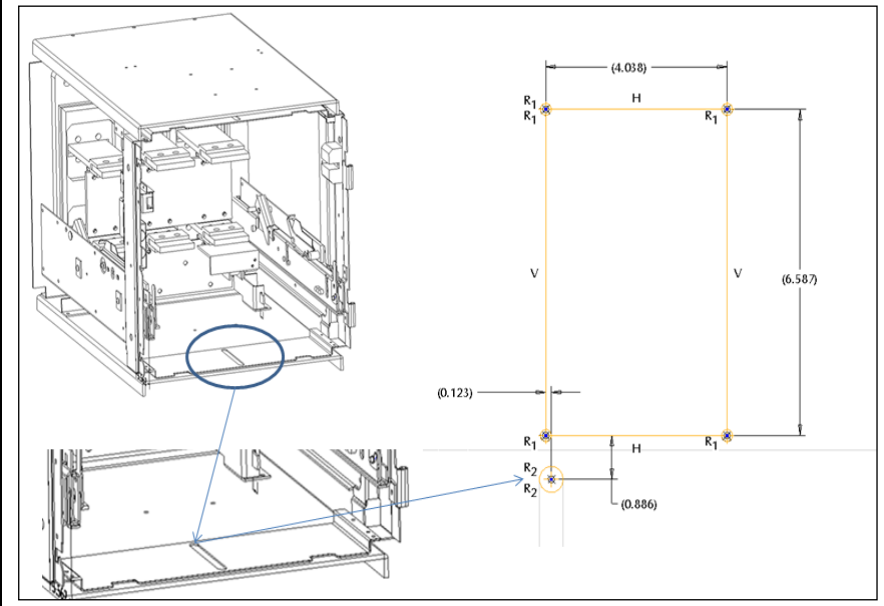
- Installing the programmer disconnect should not be carried out when the compartment is live.
- The compartment should be de-energized before the installing the programmer disconnect assembly.

NOTE: 12-Pin Programmer disconnect configuration is not provided with the AKD6 version of the Retrofills of the EntelliGuard ACB.

To install the programmer disconnect in the AKD-6 switchgear, do the following:

1. Turn off power to the switchgear, if not done already.
2. Have these tools ready for doing the task: hand-drill, cleaning solution, antirust, and wrench for metric M6 bolt/nut.
3. Clean the base of the compartment of any dirt or foreign particles, if not done already.
4. Slide the inner frame assembly to its maximum inserted condition ([Figure 32](#)).
5. This position corresponds to the frame position when the breaker would be in, fully connected.
6. Use the slot, inner semicircle as a datum reference and mark the mounting-hole locations using the template shown in ([Figure 32](#)). Dimensions shown are in inches.
7. Drill ¼-inch diameter holes at 4 locations as marked.

Figure 32. AKD-6—Slide the Inner Frame (Dimensioning)



8. Place the programmer disconnect assembly on the mounting holes ([Figure 33](#)) and secure it to the base of the programmer using hardware (Bolt—M6 X 35, Nut—M6 (metric)) provided along with the programmer disconnect assembly kit.
9. Check the movement of programmer disconnect on slides for biasing.
10. Tighten the hardware hand-tight ([Figure 34](#)).
11. From the disconnect plug, route the wire to suitable incoming cables from the compartment.

Figure 33. AKD-6—Holes Drilled for Mounting Programmer Disconnect

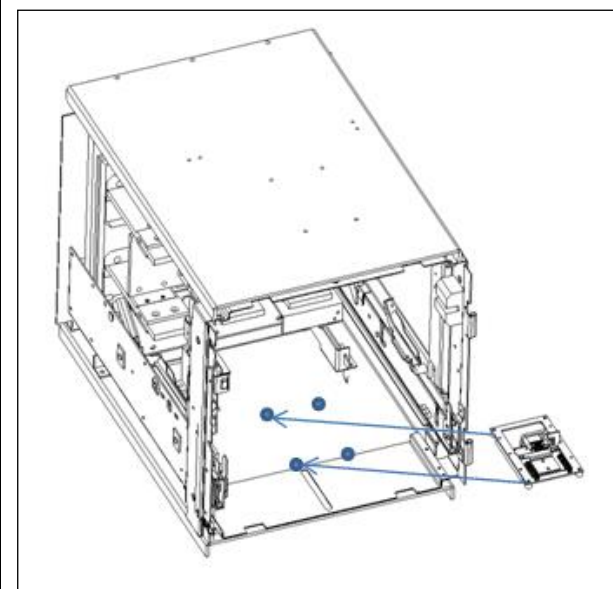
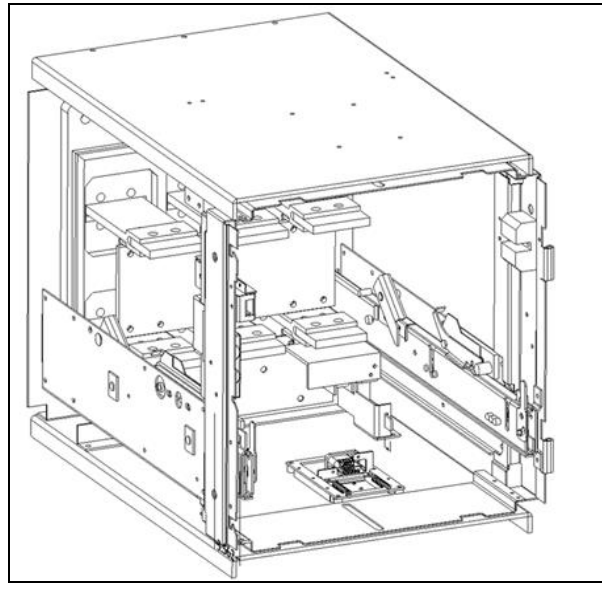


Figure 34. AKD-6—Programmer Disconnect Assembly Secured in Place



GE
Industrial Solutions
41 Woodford Avenue
Plainville, CT 06062
www.geindustrial.com

© 2015 General Electric Company



*Trademark of the General Electric Company and/or its subsidiaries.
DEH-41548 (07/15)