



# PowerMark Gold™ Load Centers

## Main Breaker Retainer & Service Barrier Kit Cat# THQLRK3

**⚡ WARNING:** Hazard of electrical shock or burn. Turn off power supplying this equipment before working inside **⚡**

### General

To comply with the National Electrical Code and Underwriters Laboratories, the breaker retainer kit and service barrier must be installed in accordance with the information contained in this sheet and by a qualified electrical contractor and/or licensed electrician.

### Introduction

This bulletin provides instructions for installing circuit breaker retainer and Service barrier to PowerMark Gold™ GE Load centers. The retainer is used to secure a 2-pole branch breaker on the load center interior when the breaker is used as a back-fed main circuit breaker. And Service barriers are installed on the line side of the breaker.

### Contents per Installation

#### THQLRK3 - Main Breaker Retainer & Service Barrier Kit

Description	Qty.
BREAKER RETAINER CLIP	1
PUSH NUT	1
THQL Lug Barrier	2
LABEL	1

**NOTICE:** These instructions do not purport to cover all details or variations in equipment or to provide for every possible contingency to be met in connection with the installation, operation or maintenance. Should further information be desired or should particular problems arise which are not covered sufficiently for the purposes, the matter should be referred to the General Electric Company. These instructions are intended for use by qualified personnel only.

### Installation Instructions

1. Uninstall the Dead front/shield and retain the mounting screws.

2. Insert the Service Barriers (A) onto line side of circuit breaker (D) as shown in Figure 1. Two Service Barriers included with the kit, need to assemble to both the poles.

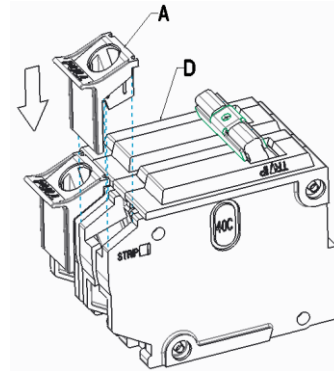

Figure 1: Insert Service Barrier onto Main Circuit Breaker

3. Install the 2-pole back-fed main circuit breaker (D) in position shown in Figure 2.

Use only a General Electric type THQL or THHQL two-pole circuit breaker.

4. With the circuit breaker still in the "OFF" position, install the retainer (F), over the boss (E), with push nut (G) and the push nut can be firmly pressed into place using a tool with a tubular end, such as a 5/16" socket or nut driver.

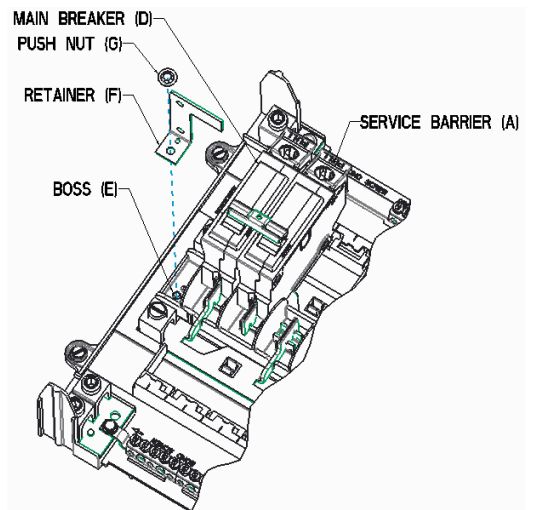

Figure 2: Install Retainer to Secure Breaker

See Figure 3, load center fully assembled with kit

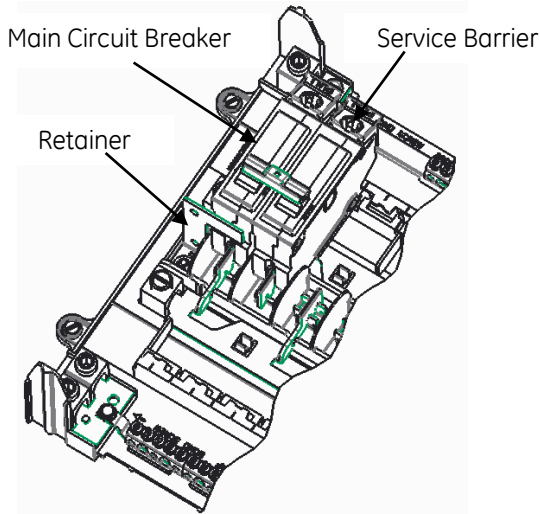

Figure 3: Shows Kit Assembled

5. Remove the backing from the enclosed "SERVICE DISCONNECT" label and attach it to the shield besides the main circuit breaker opening.
6. Wire the circuit breaker to be used as main. Fig. 4
7. The Circuit Breaker is now ready for service.

The wires must be stripped to the correct length to maintain isolation. Strip the wire to a maximum of 0.595 inches.

After stripping the wires to the required length, the wires can be installed as shown in Figure 4. The service barrier must be correctly installed to maintain electrical isolation from accidental contact. Torque the wires according to the torque specification on the breaker.

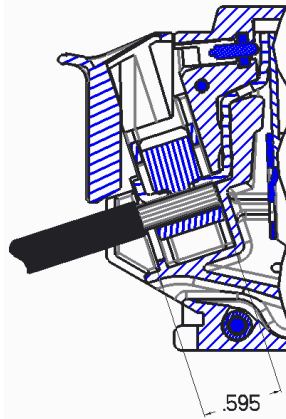

Figure 4: Stripped Wire Installed

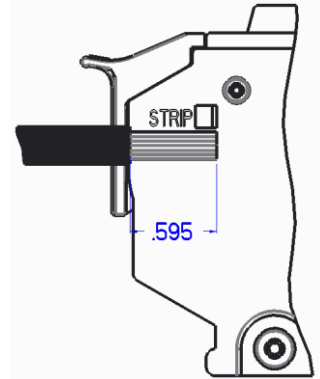

Figure 5: Max. Strip Wire Length.

The strip wire length are measured to the scale provided on side of main circuit breaker, as shown on Figure 5.

Some THQL (1p and 2p up to 60 Amps) are finger safe and do not require a Service barrier. See Figure 6.

**⚠ WARNING:** Service barriers (A) must be correctly installed on the line side of a main device in GE load centers to ensure isolation from live parts.

**⚠ WARNING:** Installing an incorrect size wire than the specified sizes for each circuit breaker frame will negate the barrier ability to protect personnel from exposed live components.

Location	Conductors
Lug Hole	10 AWG to 2/0 AWG Cu/Al

Table 1: Shows the allowable wire range for the barrier.

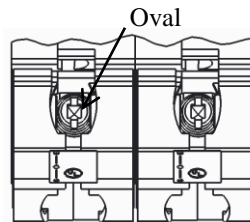

Barriers Not Required

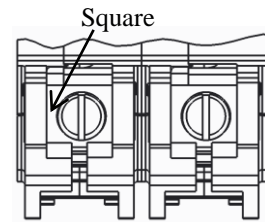

Barriers Required

Figure 6: Breakers Where Service Barriers Are Required

These instructions do not purport to cover all details or variations in equipment nor do they provide for every possible contingency that may be met in connection with installation, operation, or maintenance. Should further information be desired or should particular problems arise that are not covered sufficiently for the purchaser's purposes, the matter should be referred to the GE Company.

## Imagination at work

GE Configured Solutions  
41 Woodford Ave.  
Plainville, CT 06062  
[www.geindustrial.com](http://www.geindustrial.com)

To contact GE Industrial Solutions post sales service team, call 888-437-3765



\*INDICATES A TRADEMARK OF THE GENERAL ELECTRIC COMPANY AND/OR ITS SUBSIDIARIES.

INFORMATION PROVIDED IS SUBJECT TO CHANGE WITHOUT NOTICE. PLEASE VERIFY ALL DETAILS WITH GE. ALL VALUES ARE DESIGN OR TYPICAL WHEN MEASURED UNDER LABORATORY CONDITIONS, AND GE MAKES NO WARRANTY OR GUARANTEE, EXPRESS OR IMPLIED, THAT SUCH PERFORMANCE WILL BE OBTAINED UNDER END-USE CONDITIONS