

DEH4155 INSTALLATION INSTRUCTION FOR RIGHT POLE MOUNTING ONLY

Bell Alarm Switch Accessory Catalog. No: TEYXBA1M01



CAUTION: The device is factory installed. Before inspecting or beginning any maintenance works on the breaker, it must be disconnected from all voltage sources, both power and control, and breaker placed in the off (open).

NOTES: Any work requiring cover removal of a sealed breaker voids **UL** listing. The **UL** label must be destroyed.

This accessory to be installed in Right Pole only

DESCRIPTION

The device shown in Figure 1 is used to provide circuit breaker trip indication using a single pole double throw switch actuated by the breaker mechanism.

The standard device is supplied as shown in Figure 1.

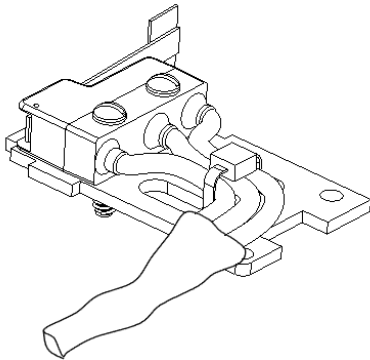

Figure 1.

STEP 1 Breaker Preparation for Field Installation.

Open breaker contacts by moving handle to the breaker "OFF" position as shown in figure 2.

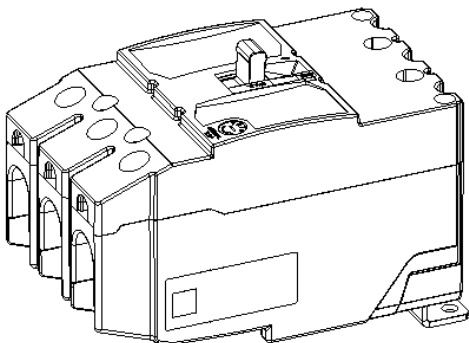

Figure 2.

STEP 2 Removing Cover

Remove breaker cover by removing cover screws as shown in Figure 3. Tar must be removed and discarded to gain access to screw.

Remove and save plastic handle and shutter.

Push trip bar towards load end to trip mechanism.

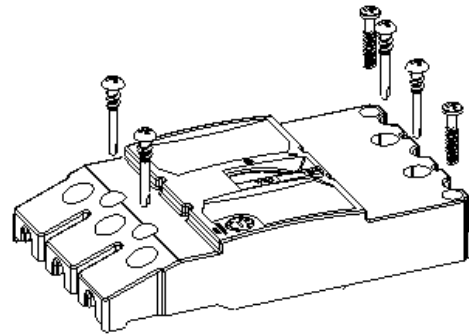

Figure 3.

STEP 3 Cover Modification for Wire Exiting

Perform cover modification as shown in Figure 4. Remove all debris.

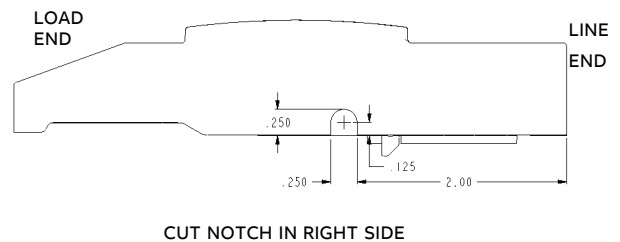

Figure 4a. Side View of Breaker Cover

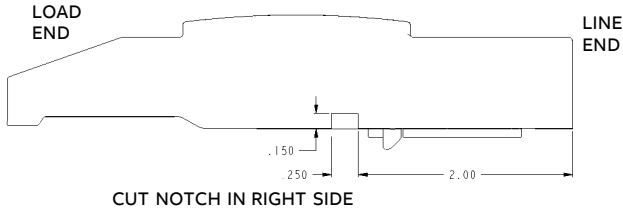

Figure 4b. Side View of Breaker Cover

STEP 4
Removing Tie Bar

Use #1 Phillips screw driver to remove the tie bar and its mounting screws from right pole as shown in Figure 5.

Save the tie bar and its mounting screws.

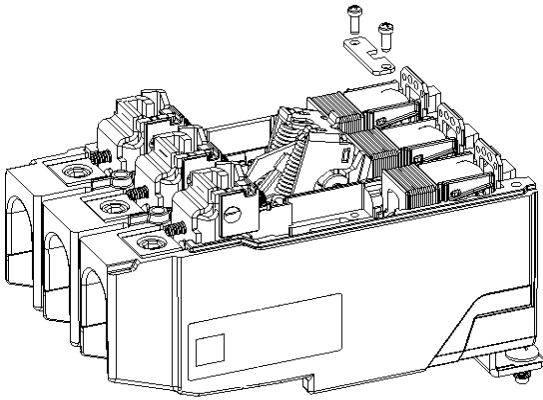

Figure 5.

STEP 5
5a. Removal of existing barrier

Remove the barrier between right pole and mechanism center pole, as shown in Figure 6a

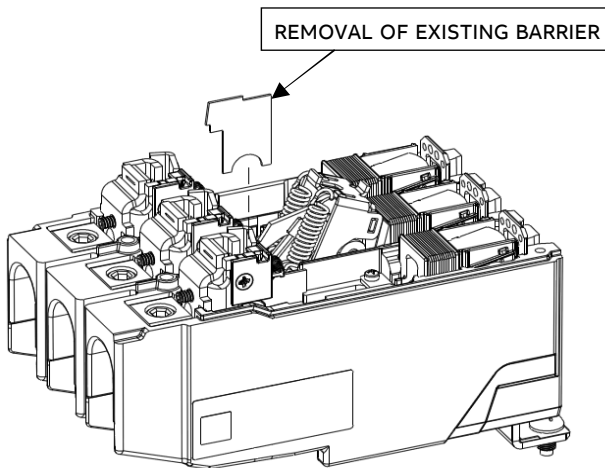

Figure 6a.

5b. Installation of Phase Barrier for Bell Alarm

Assemble the Phase barrier supplied with kit, between right pole and mechanism center as shown in Figure 6b

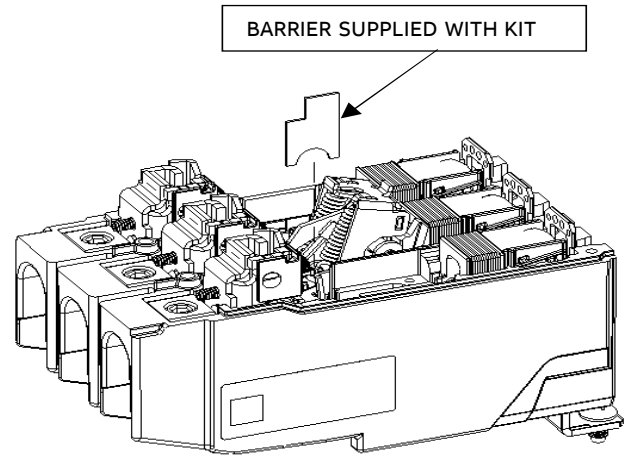

Figure 6b.

STEP 6
Installation

Drop down the Bell Alarm device in the right pole. Make sure Bell Alarm mounting base holes and holes provided in Base are in line as shown Figure 7.

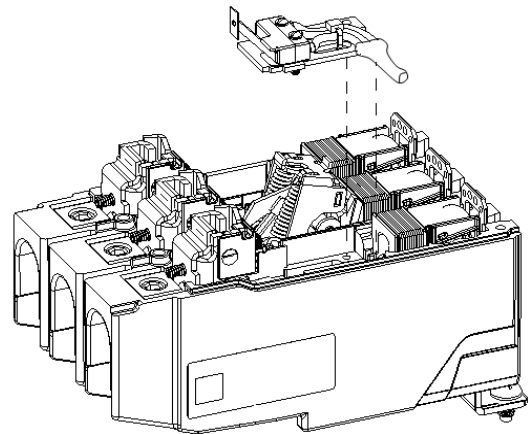

Figure 7.

Make sure the switch lever with increased over lap end properly sits on the primary latch face of the mechanism as shown in figure 8.

Be absolutely sure to reinstall parts in their proper location which are accidentally removed from the breaker.

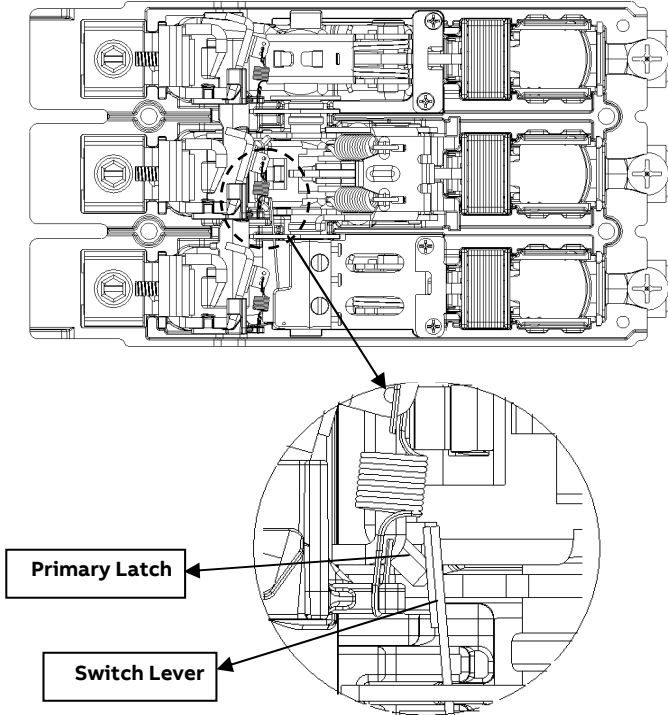

Figure 8.

STEP 7 Reinstalling Tie Bar

Re install Tie bar by placing the tie bar on the top of Bell alarm mounting base. Make sure the Tie bar holes, Bell alarm mounting base holes and Base holes are in line and tighten the mounting Screws to the torque values of 3-5 Lb-in as shown in Figure 9.

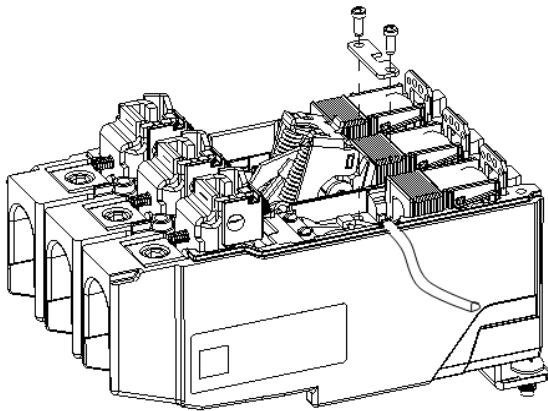

Figure 9.

STEP 8 Reinstalling Cover

Reinstall plastic breaker handle and shutter. Position the wires to match the wire exiting hole in the cover as shown in Figure 10.

Make sure no wires are pinched in the routing.

Wires must pass through the cover notch as shown in Figure 11. Make sure the cover is properly seated and tighten the four inner cover mounting screws to torque value of 12-15 Lb-in and two outer mounting screws to 18-

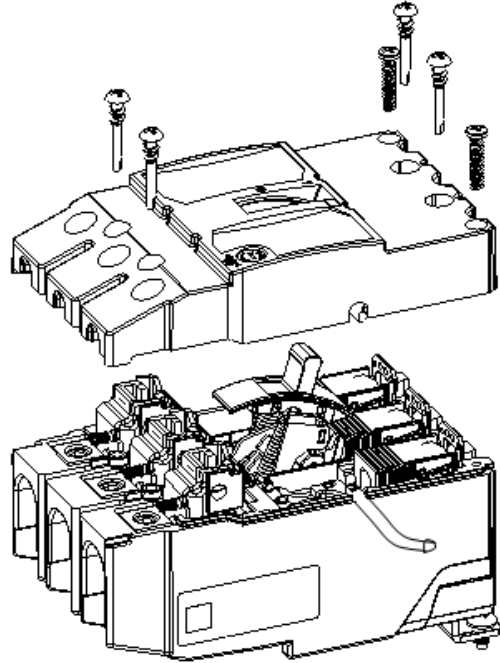

Figure 10.

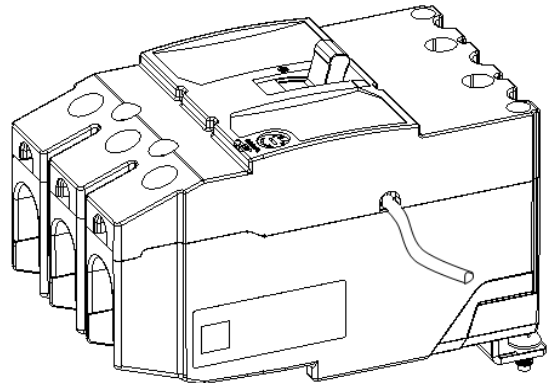
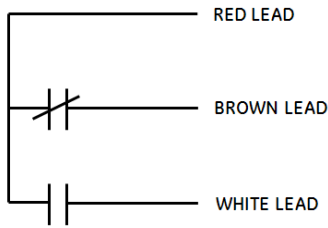
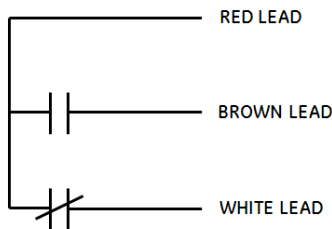

Figure 11.

Before being connected to external wiring, the contacts of the bell alarm should be electrically checked using a continuity tester with the circuit breaker in the OFF, ON and TRIP position. The state of the contacts should agree with the Schematics in Figure 11. Use the red "Twist to Trip" button to trip the breaker.



A. Circuit Breaker Tripped



B. Circuit Breaker ON or OFF

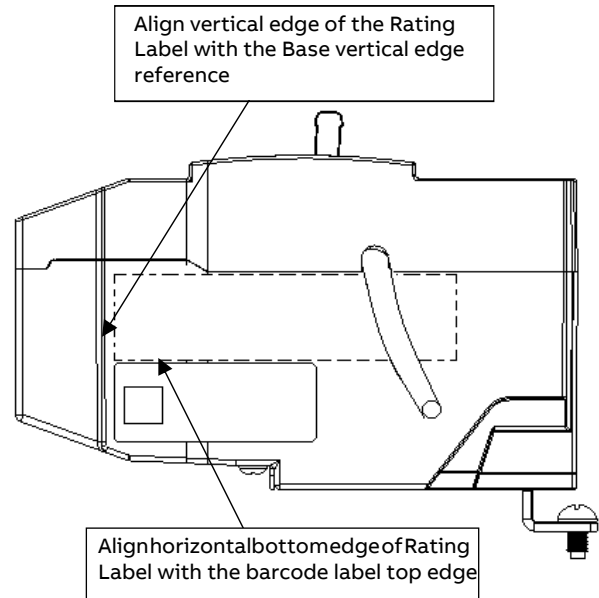

Line and Load Labels Location

Paste the Line and Load Labels, as shown in the Figure 13.

**STEP 9
Location of Labels**

Rating Label Location

Paste the Rating Label as shown in the Figure 12.

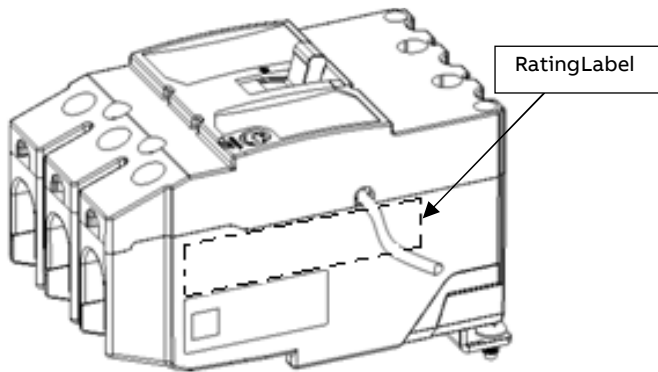

Figure 12.

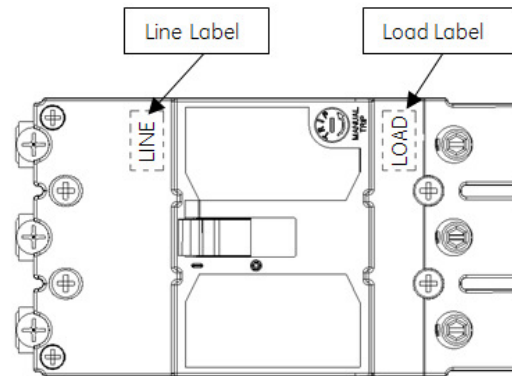

Figure 13.

These instructions do not purport to cover all details or variations in equipment nor, to provide contingency to be met in connection with installation, operation, or maintenance. Should further information be desired, or should particular problems arise which are not covered sufficiently for the purchaser's purposes, the matter should be referred to ABB Company.