

GE Energy

# EntelliGuard R<sup>®</sup> Retrofill

## Application Guide

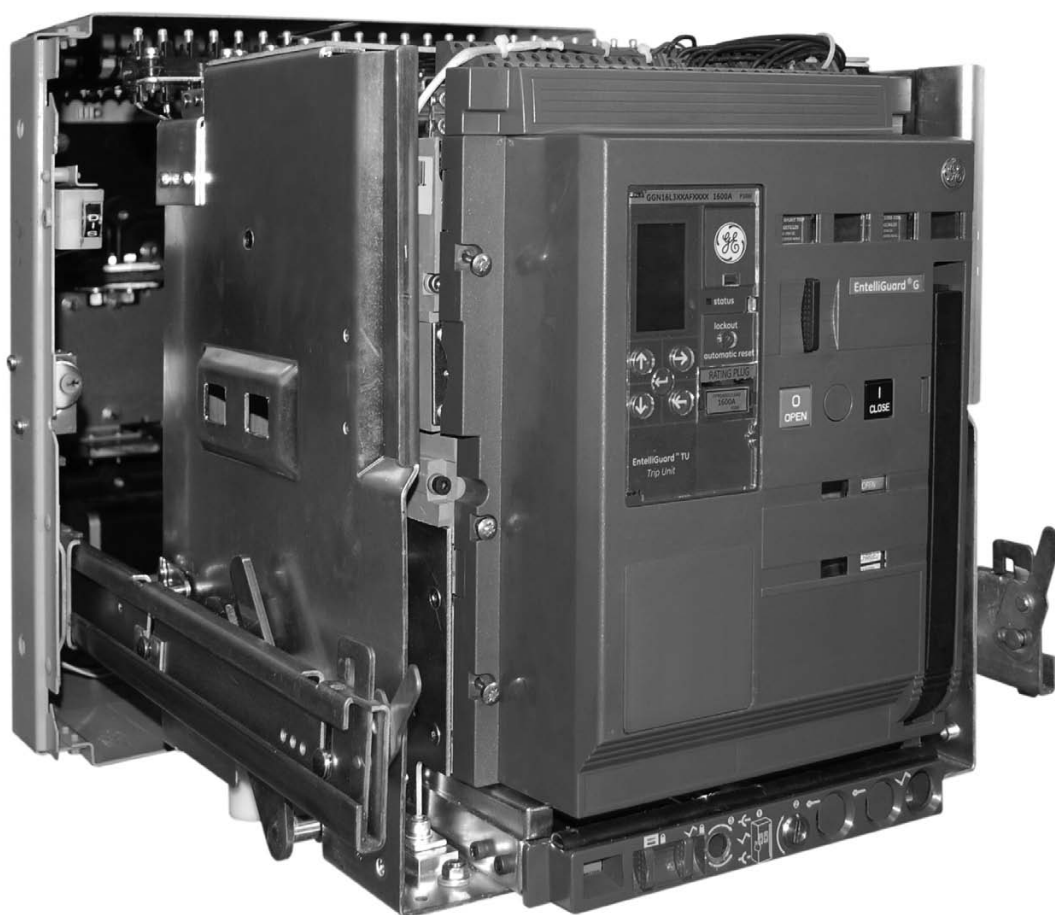

imagination at work

# Table of Contents

<b>Table of Contents</b> .....	<b>1</b>
<b>Introduction</b> .....	<b>3</b>
Benefits of Retrofill.....	3
Features.....	4
Offering and Ratings.....	6
Testing and Standards.....	7
Documentation and Drawings.....	7
Identifying GE vs. OEM.-Built Switchgear.....	7
General Installation, Labor Required.....	8
<b>Catalog Ordering Guide</b> .....	<b>9</b>
Circuit Breaker Retrofill Digits 1, 2, 3 & 4.....	9
Circuit Breaker Retrofill Digits 5 & 6.....	10
Cassette Retrofill Digits 1, 2, 3, 4, 5 & 6.....	11
<b>EntelliGuard® TU Trip Unit</b> .....	<b>11</b>
Standard Options.....	11
Advanced Options.....	11
<b>Remote Racking</b> .....	<b>12</b>
<b>AKD-5: AK25, AK50</b> .....	<b>13</b>
AKD-5 History and Description.....	13
AKD-5 Weight Data.....	13
AKD-5 Retrofill Overview.....	13
AKD-5 Lifting Bars.....	14
<b>AKD-6, -8: AKR30/30H/30L/30S/50/50H</b> .....	<b>14</b>
AKD-6 History and Description.....	14
AKD-6 Weight Data.....	14
AKD-6 Dimension Details.....	14
AKD-8 History and Description.....	15
AKD-8 Weight Data.....	15
AKD-8 Dimension Details.....	15
<b>AKD-6 and AKD-8 Retrofill Overview</b> .....	<b>17</b>
AKD-6 and AKD-8 Distinctions.....	17
<b>Neutral Rogowski Current Transformer (CT)</b> .....	<b>19</b>
Ordering Info.....	19
Original Iron-Core CT Drawings.....	21
Rogowski Neutral Bus Drawings.....	23
<b>Neutral Disconnect Assembly</b> .....	<b>24</b>
AKD-5 Switchgear Neutral Disconnect Assembly.....	24
Switchgear AKD-6 and AKD-8.....	24
Ordering Info.....	24
<b>Position Switch Actuation Assembly</b> .....	<b>25</b>
Description.....	25
Ordering Info.....	26
<b>Secondary Wiring Disconnects</b> .....	<b>26</b>
Secondary Disconnects: 7-Bullet Blocks.....	26
Ordering Info.....	27
AKD-5/6/8—Secondary Disconnects Wiring.....	27
Programmer Disconnects (12- & 19-Pin).....	29

- 19-Programmer Disconnect (AKD-6, AKD-8) ..... 30**
  - 19-Pin Programmer Disconnect Ordering Info.....32
- 12-Pin Programmer Disconnect (AKD-8) ..... 32**
  - 12-Pin Programmer Disconnect Ordering Info.....33
  - 9-Pin and 24-Pin Legacy Programmer Disconnect Details.....34
- Wiring Diagram for the AK/AKR Retrofit ..... 35**
- Finger Clusters, Spares/Replacements ..... 36**
  - Description .....36
  - Ordering Info.....36
- Shutters ..... 36**
- Door Interlock Assembly ..... 37**
  - Door Interlock Tab.....37
  - Ordering Info.....37
- Doors ..... 37**
  - Introduction .....37
  - AKD-5, AK25 Retrofit Door Assemblies.....38
    - 20-inch Door Sizes .....38
    - 22-inch Door Sizes .....38
    - 27-inch Door Sizes .....39
    - Ordering Info.....40
  - AKD-5, AK50 Retrofit Door Assemblies.....40
    - 27-inch Door Sizes .....40
    - Ordering Info .....41
  - AKD-6, AKR Retrofit Door Assemblies .....41
    - 22-inch Door Sizes .....41
    - 27-inch Door Sizes .....42
    - Ordering Info.....43
  - AKD-8, AKR30S, AKR30H, AKR 30/50 Retrofit Door Assemblies .....43
    - 22-inch and 30-inch Door Sizes.....43
    - Ordering Info.....44
  - Retrofit Escutcheon Kit—Spare.....44
- Labels ..... 45**
  - Labels on Breaker.....45
  - Labels on Door.....45
  - Ordering Info.....45
- Rejection Schemes for Retrofit ..... 45**
- Appendix A—Circuit Breaker History and Designations ..... 46**
  - Chronology .....46
  - Power Circuit Breaker Designations .....47
    - AK/AKR.....47
  - WavePro™ .....49
    - Low Voltage Power Circuit Breaker Designations .....49
  - EntelliGuard.....49

## Introduction

With over 100 years of installed switchgear, aging equipment can often be a major cause of concern. Add to that the normal wear and tear on low-voltage circuit breakers that may lead to a loss of system protection and reliability. Many times the existing switchgear is intact, but the breakers are worn out and parts are becoming harder to find. There have been many options for addressing aging breakers and a few of them are listed below.

- Buy a new metal frame breaker.
- Buy a used metal frame breaker.
- Refurbish an existing breaker (complete tear-down).
- Install a conversion kit to upgrade the “brain” of the existing breaker, such as the EntelliGuard TU Conversion Kit.
- Retrofill existing metal frame breaker with a modern technology, thermoset resin power circuit breaker.

This application guide discusses the 5th option above in detail. Contact a local GE Sales or service center to learn about other options, which are all available from GE.



The EntelliGuard R Circuit Breaker is designed to retrofill your existing low-voltage circuit breaker compartment. Completely compatible with existing AKD-5, 6, and 8-switchgear, the EntelliGuard R Circuit Breaker has the same, or even greater interrupting rating as the legacy breaker. The circuit breaker meets the standards and testing criteria of the latest version of the American National Standards Institute (ANSI), National Electrical Manufacturers' Association (NEMA), and the Institute of Electrical and Electronic Engineers, Inc. (IEEE). The photo to the left is an example of a retrofill circuit breaker replaces an AKR30 in AKD-6 switchgear. It features the EntelliGuard TU Trip Unit, providing arc flash reduction and selectivity at the same time. The 3-pole retrofill circuit breaker provides superior system protection, reliability, monitoring, and communications, and can be easily

mounted in the existing circuit breaker cubicle without modifying the cubicle bussing or racking mechanism.

### Benefits of Retrofill

EntelliGuard R Retrofill provides a streamlined solution to replace your legacy circuit breakers with a new EntelliGuard G Breaker. This would give your existing switchgear a new lease on life. Besides providing a host of new features, the EntelliGuard R Retrofill solution offers the option to of including the EntelliGuard TU Trip Unit for both arc-flash protection and selectivity at the same time. The EntelliGuard R Retrofill can provide savings right from the start because it makes the most of your existing equipment. Basically, EntelliGuard R is replacing your existing legacy breaker with a modern breaker, that is, no cubicle bus or racking modifications are required. This means minimal (or no) downtime while making the change—this is indeed the main feature of a retrofill. There are some major advantages of electing to install a GE retrofill breaker for GE equipment:

- Design based on GE original design requirements for AKD-5, AKD-6, and AKD-8 gear, including: heat rise requirements, mechanical tolerances, and bus ratings
- Through-the-door racking
- Trip Unit and all breaker indicators visible—with door closed
- UL listed and the gear continuously maintains UL listing
- Increased kAIC rating on AK25 and AKR30S, always maintaining UL certification
- Remote racking available
- Lower maintenance, fast clearing of breaker

- Minimal downtime to no downtime to install (provided there are no new features or options added in the gear)
- GE original factory drawings are available.

In general, available drawings are front-views, device arrangement (panel layout), elementary and connection diagrams for low voltage switchgear built in Burlington, Salisbury, and Philadelphia. Manufacturing drawings of the cubicles for the AKD-5, AKD-6, and AKD-8 switchgear are also provided, if requested.

- Field interchangeable accessories and secondary wiring
- EntelliGuard TU Trip Unit with advanced options. When used as a complete system, it's possible to achieve an 8 cal/CM<sup>2</sup>, or less, incident energy rating while maintaining selectivity 24x7.
- Reuses the existing secondary wiring of breaker compartment or disconnects.
- Is compatible with existing shutters in the back of your switchgear.
- Uses the same lifting device as the existing AKR breakers
- Makes the secondary disconnect wiring connection without modifying your switchgear.

## Features

The EntelliGuard R uses the robust EntelliGuard G as its core. The EntelliGuard G circuit breakers are the newest line of low voltage power circuit breakers (LVPCBs). They are developed from the exceptional designs and practices of GE legacy breakers. EntelliGuard G breakers are available in both 3-pole and 4-pole devices, 400A – 6000A, 100% rated, and are suitable for 240Vac, 480Vac, 600Vac, 690V, and 1000V applications. They are available in ANSI UL1066, UL489, UL489B, and IEC standards. To learn more about the EntelliGuard G circuit breaker, refer to [EntelliGuard G Circuit Breaker Application Guide, DET-635A](#).

The retrofit circuit breaker, like most low voltage power circuit breakers, operates on the principle of a stored-energy, closing mechanism. The mechanism is designed to discharge the stored energy before or when the circuit breaker is either installed or removed from the compartment. Breakers maintain a trip-free condition when racking handle is inserted in any position of the retrofit kits. Between the *test* and *connected* positions, the mechanical component opens and remains in a trip-free state to provide contact interlock. Electrically operated mechanisms are designed to match the existing air breaker circuits where closing and tripping mechanisms can function satisfactorily over voltages prescribed in ANSI C37-06, Table 10. Primary disconnects or finger clusters are silver-plated. Clusters are introduced in [Finger Clusters, Spares/Replacements, on Page 36](#).

Each circuit breaker assembly is equipped with a main contact position indicator or target; manual tripping and closing pushbuttons; and spring-charged and discharged indicator, or target. The retrofit circuit breakers have all new electrical components, springs, coils, and motors. Other retrofit breaker attributes are displayed here:

- Uses existing 7-bullet secondary disconnect interface (Refer to [Secondary Disconnects: 7-Bullet, Page 27](#).)
- Uses existing cubicle position switch and neutral disconnect (Note: 4-wire iron core, neutral current transformer needs to be replaced with a Rogowski style CT. (Refer to [Position Switch Actuation Assembly, Page 25](#); [Neutral Disconnect Assembly, Page 24](#); and [Neutral Rogowski Current Transformer \(CT\) on Page 19](#).)
- Wiring for the 12-Pin and 19-Pin programmer disconnects is custom-wired at the plant. (Refer to [19-Pin Programmer Disconnect \(AKD-6, AKD-8\), Page 31](#), and [12-Pin Programmer Disconnect \(AKD-8\), Page 33](#).)
- Field installable accessories: Motor, Close Coil, Command Close Coil, Shunt Trip, UVR, 8NO/8NC Aux, Ready-to-close, Network Interlock, Bell Alarm, Trip Unit, Mechanical Operations Counter, and Key Interlock. (For these items, refer to the [EntelliGuard G Circuit Breaker Application Guide, DET-635A](#).)
- New pre-punched doors: (1) breaker only, (2) breaker and pilot lights (AKD-5, 6), and (3) breaker, lights, and ammeter (AKD-5, 6) (Refer to [Doors, Page 37](#)).

- New labels for breaker and door to indicate the cubicle has been retrofilled (Refer to [Labels on Page 45.](#))
- Field wiring of secondary disconnect. Breaker ships from factory with wires coiled with wire markers. (Refer to [Secondary Wiring Disconnects, Page 27.](#))
- Single finger cluster: Reliability and less heat generated. (Refer to [Finger Clusters, Spares/Replacements, on Page 36.](#))
- Entelliguard TU: ZSI-I/ST/GF, Waveform Capture, RELT, Full Metering, Modbus/Profibus, Relaying. (For these items, refer to the *EntelliGuard G Circuit Breaker Application Guide, DET-635A.*)
- Cassette-in-cassette design for AK25 and AK50 breakers, roll-in replacement style for AKR breakers: The AK25/ AK50 is described in [AKD-5: AK25, AK50 on Page 13.](#)
- One breaker-cassette assembly combination for the AKD-6/AKD-8, where there are no changes to existing cubicle: The AKD-6 and AKD-8 are described in [AKD-6, -8: AKR30/30H/30L/30S/50/50H on Page 14.](#)

The basic design for the AKD-5 is provided in Figure 1.

**Figure 1. AKD-5 Cassette-in-Cassette Design**

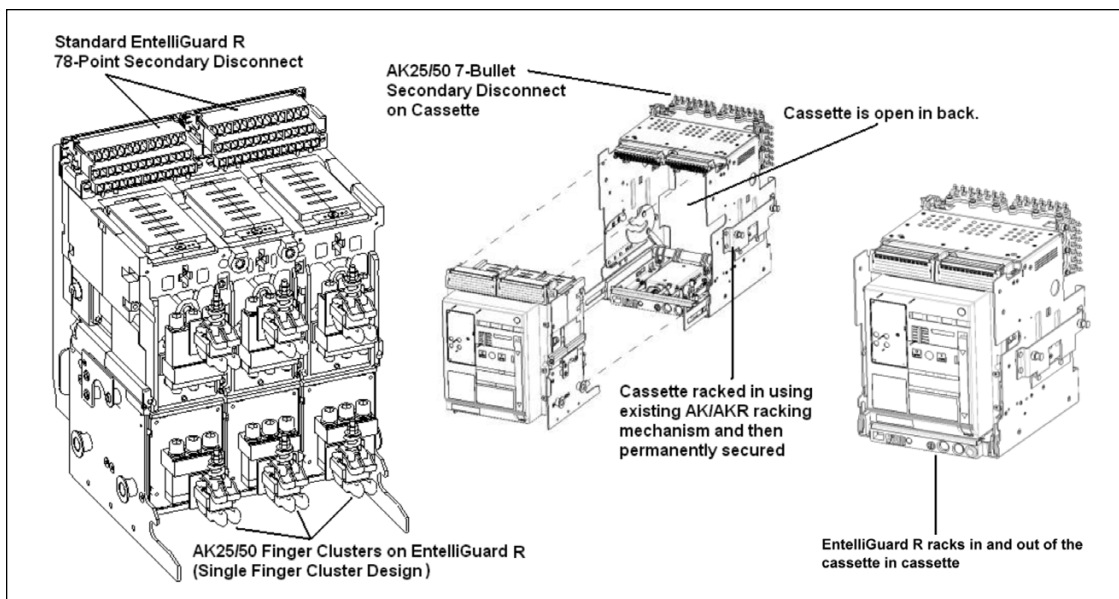
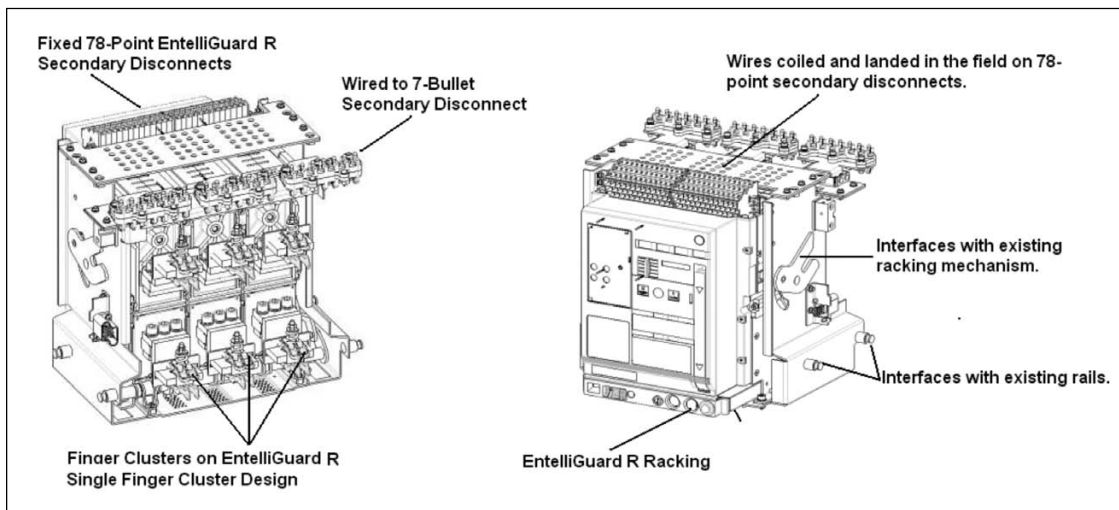

Figure 2 presents graphics for the AKD-6 and AKD-8 (AKR30/30H/30L/30S/50/50H).

**Figure 2. AKD-6 and AKD-8**



## Offering and Ratings

The initial scope of the EntelliGuard R Retrofill is 600A – 1600A feeders in either GE switchgear or switchgear built by OEMs using the AK or AKR substructure. Additional designs may be available for larger frames and non-GE devices, such as Westinghouse, Allis Chalmers, Federal Pacific, ITE, etc. A popular approach is to also use the EntelliGuard TU conversion kit on the larger circuit breakers and use the retrofill on the smaller frames (600A – 1600A). This approach provides a common trip unit platform across all breakers, which can utilize the trip unit’s advance features to provide arc-flash mitigation and selectivity at the same time. This uses the Waveform Recognition Instantaneous and Zone Selective Interlocking Instantaneous features. This chart displays interrupting ratings:

					Interrupting Rating with Inst. “kA”			Interrupting Rating without Inst. “kA”		
Switchgear Type	Thermal Rating “Max”	Breaker Type	Frame Size	CT Ratings	240V	480V	600V	240V	480V	600V
AKD5/OEM	600A	AK25	600A	600A	42*	42*	42*	22	22	22
				400A						
	1600A	AK50, AKS50	1600A	1600A	65	65	50	65	65	50
				1200A						
1000A										
800A										
AKD6/OEM	800A	AKR30, AKR30H	800A	800A	50	42	42	42	42	42
				600A						
				400A						
				1600A						
	1600A	AKR50, AKR50H	1600A	1600A	65	65	50	65	65	50
				1200A						
				1000A						
				800A						
AKD8/OEM	800A	AKR30S	800A	800A	42*	42*	42*	42*	42*	42*
				600A						
				400A						
				800A						
	800A	AKR30, AKR30H	800A	800A	50	42	42	42	42	42
				600A						
				400A						
				800A						
	800A	AKR30L	800A	800A	65	65	50	65	65	50
				600A						
				400A						
				1600A						
1600A	AKR50, AKR50H	1600A	1600A	65	65	50	65	65	50	
			1200A							
			1000A							
			800A							

For Larger Breakers, EntelliGuard TU Conversion Kits: DET-722C

EntelliGuard TU Trip Units: DEH-4567

\*Additional Modifications: Contact Factory for availability

For other Manufacturers and Breaker Types, Contact a GE Local sales Office or Factory for Availability.



## Testing and Standards

Circuit breakers and cassettes conform to ANSI C37.09, C37.20.2, and C37.55 standards, (ANSI C 37.04 and Table 2 of ANSI C37.06). Retrofill breakers are rated for these ANSI C37.09 tests: continuous current carrying design, dielectric (BIL and low-frequency withstand), momentary-current, and mechanical endurance. Note that all operating mechanisms can be easily accessed for regular maintenance. These include all new retrofill control relays, coils, motors, auxiliary contacts, and various mechanisms.

- UL or ANSI Z535.4 for safety signs and labels
- UL third-party certification testing as per ANSI C37.59
- Short circuit and withstand-testing per ANSI Standards
- Temperature rise-testing, matching original design requirements of AKD-5, AKD-6, and AKD-8
- Minimum of 500 racking operations performed on each design
- ICW shot after racking endurance to ensure Retrofill's performance
- Racking handle, dead-stop in both in/out condition to ensure no breakage of racking mechanism
- Racking positions indication accurate with no gradual change in indication after racking endurance performed
- Interlock testing and confirmation after racking endurance
- Multiple ICW shots until failure, to ensure failure is in a safe mode
- Shipping and drop tests
- Corrosion and humidity testing
- Chemical and particulates environment—Meets standards for adverse environmental conditions. Refer to *Table 1.1* in the *EntelliGuard G Circuit Breaker Application Guide*.
- Altitude above sea level standards per EntelliGuard G
- Manufactured in same factory as AK and AKR, using the same gauges to comply with design tolerances
- Manufacturing Certified Test Report for each breaker

The retrofill circuit breaker tests reflect the criteria established with ANSI C37.09, Article 5.1, and C37.20.2, Article 5.3, and are permanently recorded. You are invited to visit the factory during manufacture and assembly to observe our quality process.

## Documentation and Drawings

All schematic diagrams and nameplate information are available. Besides the schematics and nameplates, instruction books, certified tests reports, complete parts list, recommended spare parts lists are provided with the retrofitted breakers and cubicles.

## Identifying GE vs. OEM-Built Switchgear

If the equipment is GE-built, displayed on the switchgear is a metal nameplate, stating "GE AKD-5," "GE AKD 6," or "GE AKD-8," and providing requisitions and summary numbers. OEM-built equipment would not have this type of nameplate. Typically, the OEM sections would be wider than the equivalent AKD stacks.



## General Installation, Labor Required

Installing the EntelliGuard R Circuit breaker should be performed by a licensed electrician or service organization. The amount of time it takes varies, or depends, on what the present “AS IS” arrangement is already, and what the desired arrangement is in the “TO BE” state. A simple feature-for-feature retrofill with no new options can be done in 20 minutes or less.

The following are accessories or options requiring time and effort in the field:

- Retrofill breaker/cassette secondary-wire landing—inspection to match existing cubicle wiring
- Neutral iron core-to-Rogowski CT replacement in cable compartment (4-wire ground fault)

If the neutral sensor in the existing equipment is changed to a Rogowski coil, the wiring needs to be changed because it is recommended that a twisted-pair wire be used from the Rogowski coil to the breaker. The existing iron core neutral sensor uses two single conductor wires, not a twisted pair. If the kits require the Rogowski neutral CTs listed in the application guide, DET 653B, Page 50, Table 4.30a, a twisted-pair harness comes with the CT. If the encased ones are used, listed in Table 4.30, customers must furnish their own twisted-pair harness (Refer to DEH-41387). For AKD-20, the encased CTs are used.

- 2-wire neutral disconnect cubicle rewiring (AK25, AK50 only when 4-wire ground fault is required)
- 19/12-pin programmer disconnect (AKR only, used for advanced trip-unit options)
- 7-bullet, cubicle wiring (used only when an additional secondary block is needed for a new feature)
- Door replacement, and if desired, a door interlock
- Any cubicle work (cleaning, repairing, securing wires, etc.)
- Adding new options: position switch, Kirk key, rewiring/adding pilot lights, power supplies, voltage conditioners, Modbus communications wires

Before replacing your existing circuit breaker with a retrofill, you need to know what type of gear and breaker you currently have. The gear and breaker have to be correctly identified. The next section discusses AKD-5, AKD-6, and AKD-8 switchgear, made by both GE and OEMs, using the AK and AKR substructures to build their switchgear.

**Note:** Historically, the AKD-5 LVS system was not offered any time with AKR series breakers. Only AKD-6 gear initially offered both AK series breakers and AKR series breakers.

Determine type of breaker used in AKD-6:

- If the racking system is mounted on the left side wall of the compartment, order AKD-5 cassette-in-cassette type retrofill kits: AK50 (max. 1600A) and AK25 (max. 600A).
- If the racking system is not mounted in the compartment and is instead integrated in the breaker, order AKD-6 roll-in type retrofill kits: AKR50/50H (max. 1600A) and AKR30/30H (max. 800A).

# Catalog Ordering Guide

The following introduces a legend or table to assist you in selecting different retrofill options for the AKD-5, AKD-6, and AKD-8 retrofill circuit breakers. The digit references and the sample catalog numbers, located under the column headings, define general categories of option types, forms, ratings, controls, and sundry features. Following this legend are tables with specific options (Digits 1 through 6) where you can select various retrofill combinations by selecting matching codes and digits. For Digits 7 through 20, representing additional options and features not included in this application guide, can be found in [EntelliGuard G Circuit Breaker Application Guide, DET-635A](#). A configurator is available from your local field sales office.

EntelliGuard R ANSI Retrofill Circuit Breaker Catalog Number Guide

SAMPLE CAT NO.	R	1	06	D	X	H	E	R	X	5	R	A	X	X	L4	X	6	K	
DIGIT	1	2	3&4	5	6	7	8	9	10	11	12	13	14	15	16&17	18	19	20	
	Circuit Breaker Family	Equipment Manufacturer Type	Current Rating Sensors	Legacy Breaker Type	Secondary Disc & Ha Spring Charge Motor			Shunt Trip	UVR	2nd Shunt Trip 2nd UVR			Aux Switch, Coil Signaling Contact Bell Alarm, Mechanical Counter Trip Annunciation	Key Interlock & Padlock Device Mechanical Interlock		Overcurrent Protection Ground Fault ZSI		Adv. Features & Comm	Rating Plug

EntelliGuard R Cassette Catalog Number Guide

SAMPLE CAT NO.	R	1	06	D	3
DIGIT	1	2	3&4	5	6
	Circuit Breaker Cassette Family	Breaker Switch Type	Current Rating	Cassette AIC Rating	# of Poles Shutters

EntelliGuard TU Trip Unit for EntelliGuard R Breakers

SAMPLE CAT NO.	GG	N	06	L4	X	6	A	XXXX
DIGIT	1&2	2	4&5	6&7	8	9	11	11-14
	EntelliGuard Trip Unit Form	Frame Rating	Sensor Rating	Overcurrent Ground Fault Protection	ZSI		Adv. Features & Comm	Future Use Manual Auto Trip Reset

EntelliGuard TU Trip Unit Rating Plugs

SAMPLE CAT NO.	GTPU	0600	U	06	16
DIGIT	1,2,3,4	5,6,7,8	9	10,11	12,13
	EntelliGuard TU Trip Unit Rating Plug	Universal Trip Plug	Smallest sensor that accepts this plug (1600A)	Largest sensor that accepts this Plug (4000A)	

Retrofills have max 35 Secondary Disconnects Available

## Circuit Breaker Retrofill Digits 1, 2, 3 & 4

Digit 1—Circuit Breaker Family	
Device Series/Line	Code 1
EntelliGuard R Retrofill Breaker/Switch	R

Digit 2—Equipment Manufacturer & Gear Type	
Equipment Type, Manufacturer	Code 2
GE, AKD-5	1
GE, AKD-6	2
GE, AKD-8	3
OEM, AKD-5 OEM Express/Cradles	4
OEM, AKD-6 OEM Express/Cradles	5
OEM, AKD-8 OEM Express/Cradles	6

Digits 3 & 4—Sensor Size	
Current Sensor Rating (A)	Code 3&4
Non-Automatic Switch (no trip unit)	XX
400	04
600	06
800	08
1000	10
1200	12
1600	16

GE Gear has the General Electric logo and a nameplate with both a requisition number and summary number.

OEMs use GE switchgear shells to produce their own switchgear, or would purchase the circuit breaker cradles, and then build their own gear around the cradle.

AKD-8 breakers for GE gear are not able to go into OEM cells and vice versa.

Additional Characters reserved for other manufacturers

Sensor size cannot exceed the frame size of the circuit breaker. See Code 5 for frame size of each breaker.

Smallest sensor size for a 1600-amp frame is 800 amps.

Non-automatic switches "XX" are the standard retrofill without a trip unit, flux shifter, current sensors. Must have a shunt trip selected in Digit 9 or Digit 11 to open the switch remotely.

## Circuit Breaker Retrofill Digits 5 & 6

Digit 5—Circuit Breaker Type		
	Breaker Manufacturer (Digit 2)	
Frame Size	GE (1,2,3,4,5,6)	Code 5
225A	AK-1-15	A
225A	AK-15	B
600A	AK-1-25	C
600A	AK-25 (AKD-5) (Complete Series)	D
600A	AKU-25	E
600A		F
800A	AKR30, AKR30H (AKD-6, AKD-8)	G
800A	AKRU-30 (AKD-6, AKD-8)	H
800A	AKR30L (AKD-8)	I
800A	AKR30S, (AKD-6, AKD-8)	J
800A	AKRU-30S (AKD-6, AKD-8)	K
800A		L
1200A		M
1600A	AK-50, AKS-50 (AKD-5, AKD-6)	N
1600A	AKU-50, AKSU-50	O
1600A	AKR-50, AKR-50H (AKD-6, AKD-8)	P
1600A	AKRU-50	Q
1600A		R
1600A	AKJ-50, AKJ-50H	S
2000A	AKT-50, AKST-50	T
2000A	AKRT-50, AKRT-50H	U
2000A	AKJT-50, AKJT-50H	V
2000A		W
3000A	AK-75	X
3000A		Y
3000A		Z
3200A	AKR-75	1
3200A		3
3200A		4
4000A	AK-100	5
4000A	AKR-100	6
4000A	AKW-100	7
4000A		8
5000A	AKR-125	9
5000A		0

**Note:** Non-highlighted cells; contact factory for availability.

Digit 6—Secondary Disconnect & Harnesses			
Breaker	Gear Type	Sec Disc Type and Harness	Code 6
AK	AKD-5	EntelliGuard G 78 PT Drawout Secondary Disc	X
AKR	AKD-6/8	No Sec Disc Bullets or Harnesses	1
AKR	AKD-6/8	A,B,C (21 Points) Bullets Disc Installed	2
AKR	AKD-8 Only	A,B,C Disc & 12-Pin Programmer Harness	3
AKR	AKD-6/8	A,B,C Disc & 19-Pin Programmer Harness	4

AK Breakers secondary bullet disconnects are mounted on the cassette. Refer to the cassette catalog number for selecting similar secondary options. All AK retrofills come with the 78-Point secondary disconnect.

Each secondary disconnect Block comes with 7 secondary disconnect points (known as bullets). Each bullet has wires attached with wire markers on both ends to be landed on the EntelliGuard R's 78-point secondary disconnect, based on the wiring scheme of the original breaker.

AKD-6 and AKD-8: 12-pin and 19-pin programmer disconnects are used when advance options are selected on the trip unit (Digit 19 = 1 through 9) or if the input/output contacts are used on the standard trip unit (Digit 19 = X).

Pin-outs of 12- and 19-pin harness from factory:

Pin #	Feature
1	ZSI In +
2	ZSI In -
3	ZSI Out +
4	ZSI Out -
5	VoltA
6	VoltB
7	VoltC
8	24VDC-
9	24VDC+
10	Iso Grnd
11	Rx
12	Tx
13	Input 1 (RELT Input)
14	Input 1 Common (RELT Input)
15	Output 1 (If RELT Optioned, Dedicated to RELT)
16	Output 1 Common (If RELT Optioned, Dedicated to RELT)
17	Output 2 (GFA, Current Alarm, Health, etc.)
18	Output 2 Common (GFA, Current Alarm, Health, etc.)
19	Open

## Cassette Retrofill Digits 1, 2, 3, 4, 5 & 6

Digit 1— Circuit Breaker Family	
Device Series/Line	Code 5
Entelliguard R Retrofill Breaker/Switch	R

Digit 2— Equipment Manufacturer and Gear Type	
Equipment Type, Manufacturer	Code 2
GE, AKD-5	1
OEM, AKD-5 OEM Express/Cradles	4

GE Gear has the General Electric Logo and a nameplate with a requisition number and summary number.

OEMs used GE Switchgear shells to produce their own switchgear or would purchase the circuit breaker cradles and then build their own gear.

Digits 3,4 & 5— Frame Size, Breaker Type	
Current Sensor Rating (A)	Code 3, 4 & 5
600 AK25	06D
1600 AK50, AKS50	16N

Digit 6— Secondary Disconnects	
Secondary Disconnect	Code 6
None	1
A,B,C Bullets (AK50, AKS50)	2
A,B,C,D Bullets (AK25)	3

**Note:** If only one secondary disconnect block is desired, order the "None" option and then order the Secondary Disconnect Block Kit, 386A110G2.

## Entelliguard R TU Trip Unit

### Standard Options

The EntelliGuard R Retrofill breaker uses the innovative EntelliGuard TU Trip Unit, enabling Arc Flash and Selectivity at the same time. In addition to the 44 I<sup>4</sup>T and I<sup>2</sup>T time-current bands, flexible delay settings, the EntelliGuard TU comes standard with a:

- 10-Event Log
- Backlit LCD
- 2-I/O for alarms
- Status LED Indicator
- Waveform Recognition Instantaneous Algorithm

### Advanced Options

Advanced options include:

- Instantaneous Zone Selective Interlocking (enabling arc-flash and selectivity at the same time)
- Waveform Capture
- Reduced Energy Let-Through (RELT)
- Advanced Metering & Relaying
- Modbus/Profibus communication protocols

To learn more about the EntelliGuard TU Trip Unit, refer to the manual [DEH-4567—Installation, Operation, and Maintenance Manual for the UL Versions of the EntelliGuard TU Trip Unit](#). Also refer to the [EntelliGuard G Application Guide DET-635A](#) for available settings.

## Remote Racking

EntelliGuard R Retrofills use the same racking device (catalog number: EGGRRLV) as the EntelliGuard G Breaker. It is mounted via the racking tube on the cassette; the door or breaker does not need to be modified. The remote racker comes with a 30-foot cable allowing the operator to be out of range from the arc flash boundary as shown in Figure 3. For more information on remote rackers, refer to brochure [DET-440A, Low Voltage Switchgear Remote Racking Devices](#).

Figure 3. Remote Racker with 30-Foot Cable

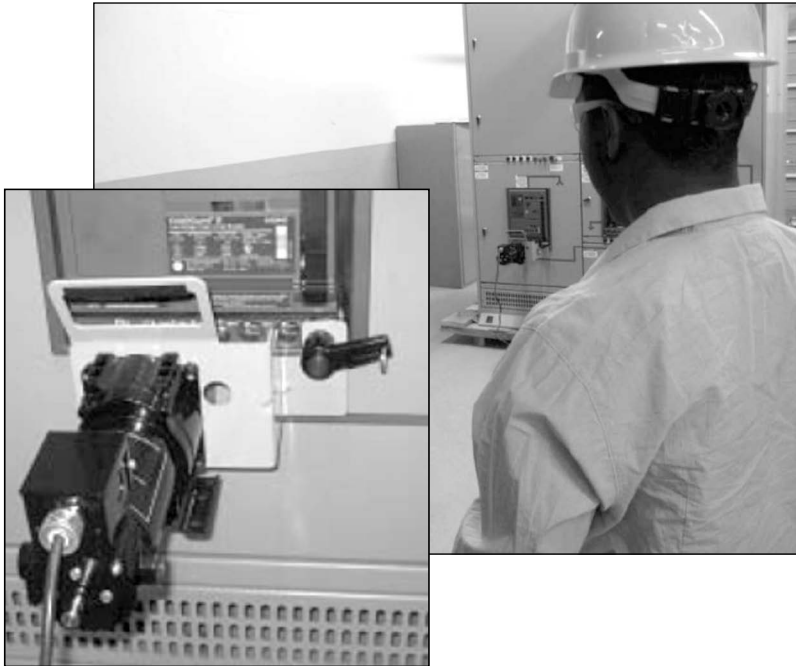

## AKD-5: AK25, AK50

### AKD-5 History and Description

Manufactured from 1960 until 1977, the aluminum bus had copper that was “flash-butt welded” to the aluminum at bolted connections. During that time, AK-2A, 3A-25 / 50 / T50 / 75 / 100 (“A” signifies AKD-5 drawout) were produced. Pull-lanyard drawout mechanism on early design was replaced by a single jackscrew mechanism and then later replaced by a double jack-screw mechanism. Featured is a closed-door, drawout with inner house breaker compartment. There is a 60”-deep frame with the 18”-extension option. Outdoor protected aisle uses 60”-deep indoor frame. Two bus levels are available with a ring bus used at 4000A. Particulars include: welded/riveted frame, bus compartment barriers, line/load separation barriers on mains and ties, isolation barriers on transformer transitions, copper runbacks on feeder breakers, ring silver-plating on copper, and aluminum bus un-plated (welded connections). The switchgear is painted sand-gray (beige), with some instrument doors painted blue. AKR-30/50 in 22”-wide sections were introduced in AKD-5 construction, early 70s. AK25s and AK50s were also available as substructure kits for OEMs to build around customer gear.

### AKD-5 Weight Data

Retrofill Breaker	Weight	Box Weight 10101653P1	Pallet 10101650P1 Weight	Accessories Weight	Total Weight
AK25	197	16	33	2	248
Retrofill Breaker	Weight	PB2 Large Frame Box Weight 10101653P1	Pallet 10101513P1 Weight	Accessories Weight	Total Weight
AK25	200	11	24	2	237
AK50	289	11	24	2	326
Retrofill Breaker	Weight	Box Weight 10101655P1	Pallet 10101650P1 Weight	Accessories Weight	Total Weight
AK50	289	18	33	2	342

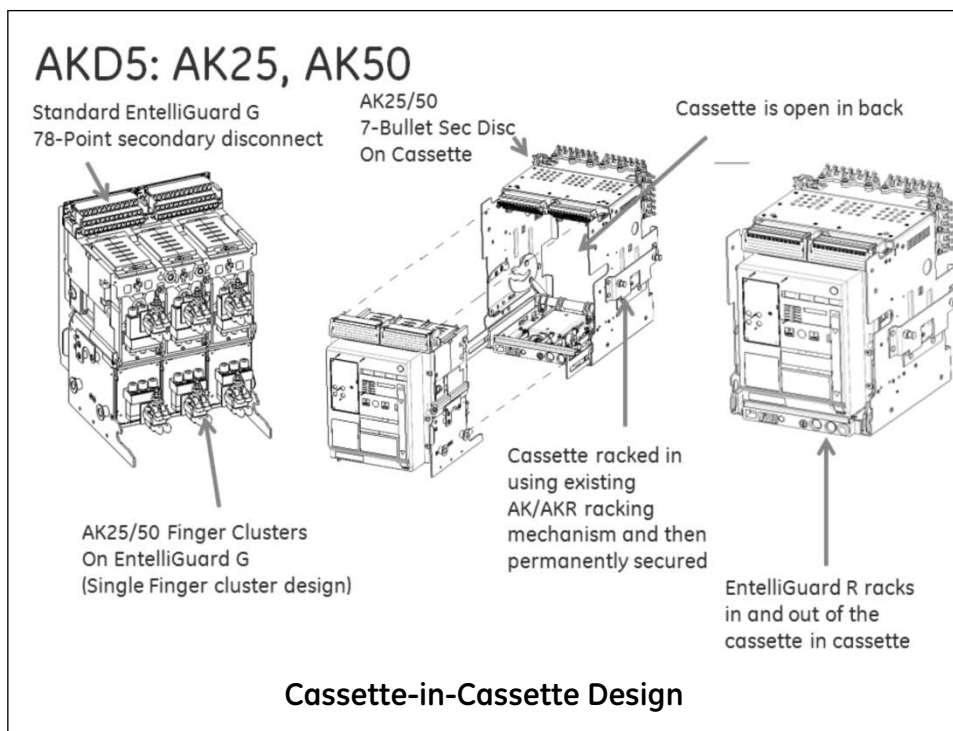

### AKD-5 Retrofill Overview

AKD-5 uses a cassette-in-cassette design. A cassette with no back plane/copper connections is racked into the cubicle with the existing racking mechanism. The cassette has the secondary bullet disconnects mounted to interface with the existing cubicles’ secondary plates. The sides of the cassette have been modified to include the locating pins to interface with the existing rails.

Once the cassette is racked in, it is permanently held in place and the original racking mechanism is no longer used. The EntelliGuard G Breaker has been modified to have the original finger clusters so they are located to match the existing cubicles’ bussing. The breaker racks

into the cubicle using the EntelliGuard R’s racking mechanism in the cassette. A new door is installed to provide through-the-door racking.

## AKD-5 Lifting Bars

Lifting bars are used to lift the breaker without causing potential damage resulting from uneven lifting. EntelliGuard R Retrofills use the legacy AKR lifting bar for AKD-6 and AKD-8 switchgear. For the AKD-5 Switchgear (AK) breakers, the lifting bar is the same bar used for EntelliGuard G Envelope 1 devices. Refer to the [EntelliGuard G Application Guide, DET-653A](#), for the latest available offerings.

## AKD-6, -8: AKR30/30H/30L/30S/50/50H

### AKD-6 History and Description

The AKD-6 was manufactured in Salisbury, NC from 1977 to 1981. Some AKD-5s, which were built in Salisbury from 1975 until 1977, got name-plated as AKD-6. There is no “flash-butt” welded aluminum to copper. Aluminum bus is tin-plated and bolted at shipping splits (but welded everywhere else). Copper bus design has ring silver-plating at bolted joints. AKR-75 / 100s were introduced during this time. Stab-and-finger connections on 3200A and 4000A breakers were improvements, versus the round-primary disconnects located on the AKD-5s. The AKD-6 uses inner-house drawout breaker compartments and tuning-fork primary disconnects (extrusions) on the 800–2000A breaker compartments. They have copper feeder breaker runbacks and 60”-deep frames with 18”-optional rear extensions. They are painted ANSI 61 light gray and breakers have ECS or SST trip units.

### AKD-6 Weight Data

Retrofill Breaker	Weight	Box Weight 10101653P1	Pallet 10101650P1 Weight	Accessories Weight	Total Weight
AKD6	213	16	33	2	264
Retrofill Breaker	Weight	PB2 Large Frame Box Weight 10101653P1	Pallet 10101513P1 Weight	Accessories Weight	Total Weight
AKD6	213	11	24	2	250

### AKD-6 Dimension Details

This drawing ([DWG 1](#)) dimensions the AKD-6.

DWG 1. AKD-6 Dimensions

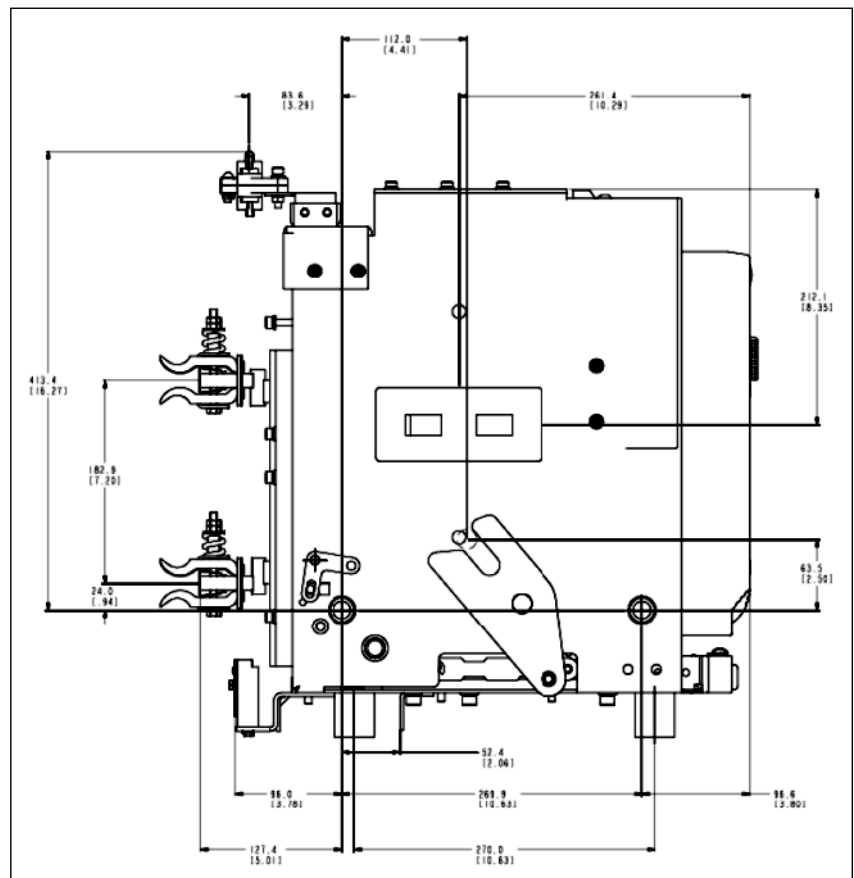



## AKD-8 History and Description

The AKD-8 was produced from 1981 to 1999. It is still available today on a limited basis. Models 1 and 2 have extruded vertical buses. Model 2 was introduced in 1983 to accommodate automated wiring programs and harness routing. Model 3 was introduced in 1991, using a flat bar, vertical bus. AKR breakers used MicroVersaTrip 9, RMS9, EPIC, MVT Plus, MVT PM, and EntelliGuard TU trip-units. The aluminum bus was removed from design in 1996 in favor of the standard tin-plated, copper bus (silver-plating optional). Field convertible space compartment design was added to allow empty compartments to be modified for functioning breaker compartments without modifying the vertical bus.

## AKD-8 Weight Data

Retrofill Breaker	Weight	Box Weight 10101653P1	Pallet 10101650P1 Weight	Accessories Weight	Total Weight
AKR30S	184	16	33	2	235
Retrofill Breaker	Weight	Pb2 Large Frame Box Weight 10101653P1	Pallet 10101513P1 Weight	Accessories Weight	Total Weight
AKD8	277	18	33	2	330
Retrofill Breaker	Weight	Box Weight 10101655P1	Pallet 10101650P1 Weight	Accessories Weight	Total Weight
AKR30S	184	11	24	2	221
AKD8	277	11	24	2	314

## AKD-8 Dimension Details

The next two drawings ([DWG 2](#)) and ([DWG 3](#)) dimension the AKD-8.

### DWG 2. AKD-8 Dimensions, View A

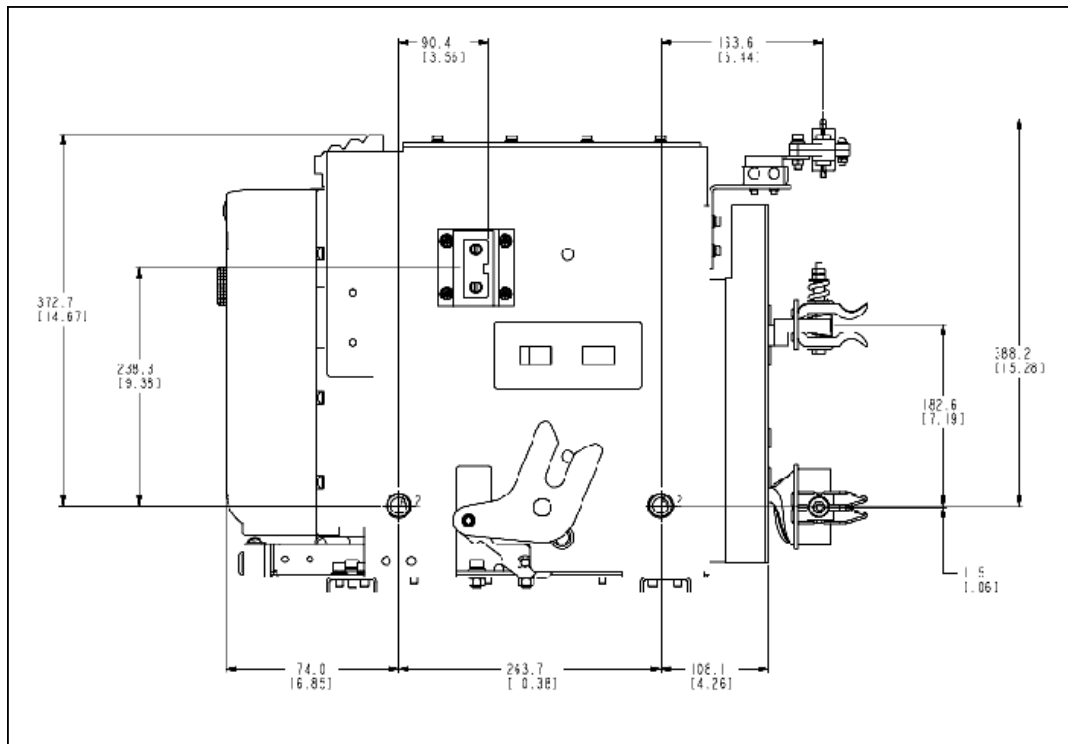

DWG 3. AKD-8 Dimensions, View B

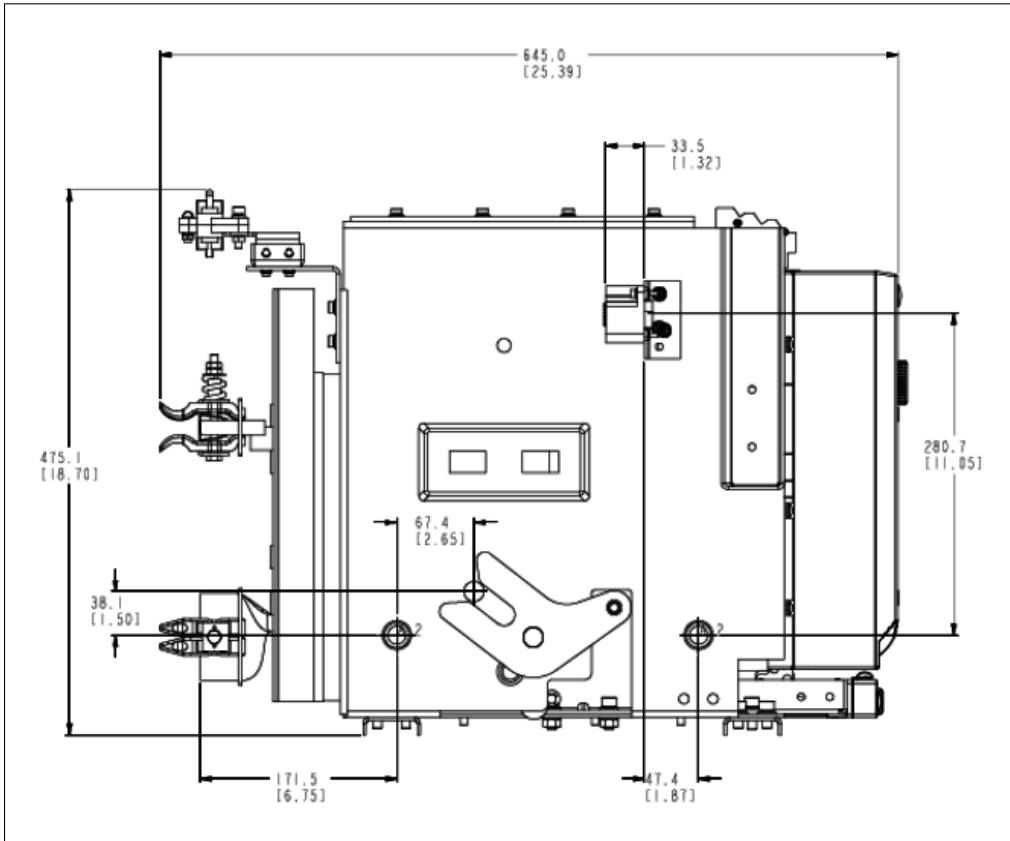

## AKD-6 and AKD-8 Retrofill Overview

AKD-6 and AKD-8 use a roll-in replacement design, utilizing the existing racking mechanism.

The EntelliGuard G breaker is modified as follows:

- EntelliGuard G is a one-unit assembly with the breaker and cassette merged into one, inseparable breaker.
- The side plate has been modified to include the locating pins and racking mechanism (ear), interfacing with the existing cubicle rails.
- Secondary disconnect (bullets), neutral, and programmer disconnects are mounted on the breaker.
- Finger clusters are located to match the existing cubicles bussing.
- A new door is installed to provide through-the-door racking.

### AKD6, 8: AKR30/30H/30L/30S/5-/50H

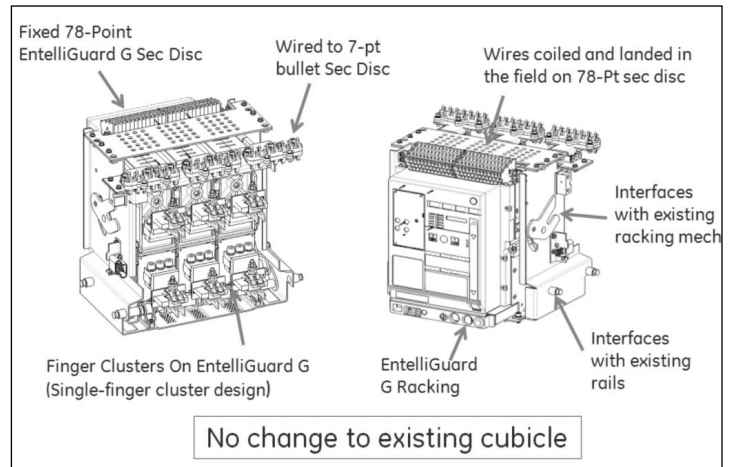

Below is a wireframe diagram showing an AKR breaker installed in the AKD-6 switchgear (Figure 4).

**Figure 4. AKR Breaker in AKD-6 Switchgear**

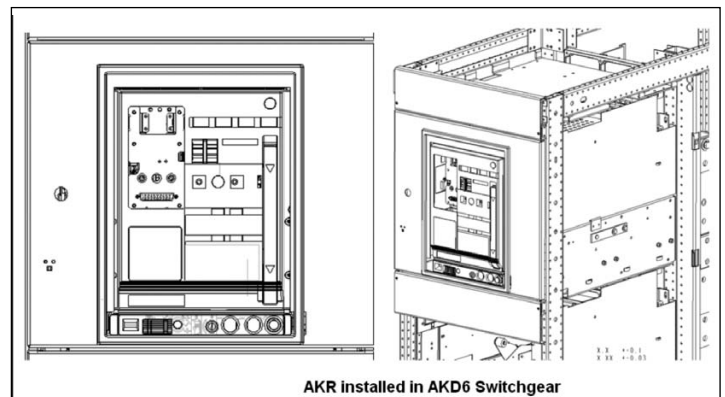

## AKD-6 and AKD-8 Distinctions

[Table 1](#) and [Table 2](#) succinctly display the distinctions between the AKD-6 and the AKD-8.

**Table 1. AKD-6 and AKD-8 Breakers**

Compared Features	AKD-6	AKD-8
Center distance between slide pins	10.63"	10.38"
Orientation of terminals O/G (Outgoing)	Horizontal	Mixed
Depth of breaker (front escutcheon)	19.44"	23.98"
Distance from rear slide pin to terminal edge	5"	6.75"

**Table 2. AKD-6 and AKD-8 Compartments**

Compared Features	AKD-6	AKD-8
Indicators	Compartment (See <a href="#">Figure 5</a> )	Breaker
Door	Movable	Stationary
Locking tabs for locking inner and outer rail	Available (See <a href="#">Figure 6</a> )	Telescopic rail (See <a href="#">Figure 8</a> )
Shutter assemblies, programmer disconnects	Not provided	Provided as accessories (See <a href="#">Figure 7</a> )

Figure 5. AKD-6 Compartment Indicator, Example



Figure 6. AKD-6 Compartment, Locking Tab for Slides

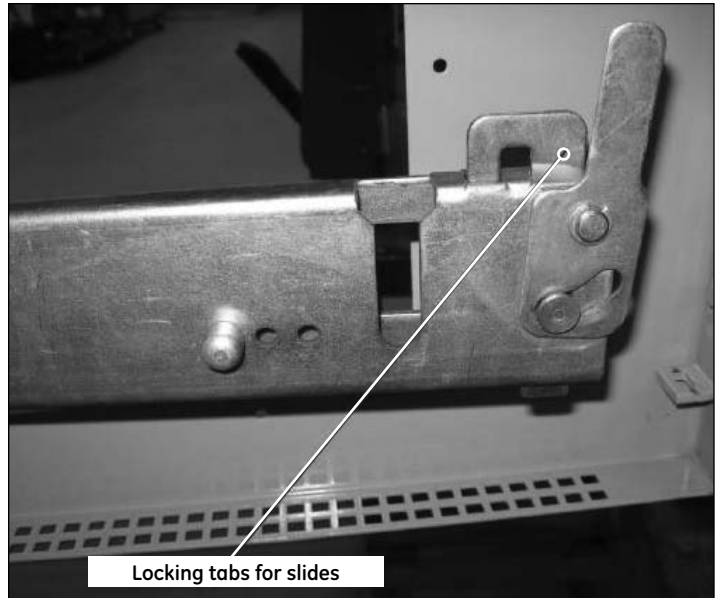

Figure 7. AKD-8 Compartment, Shutter Assembly

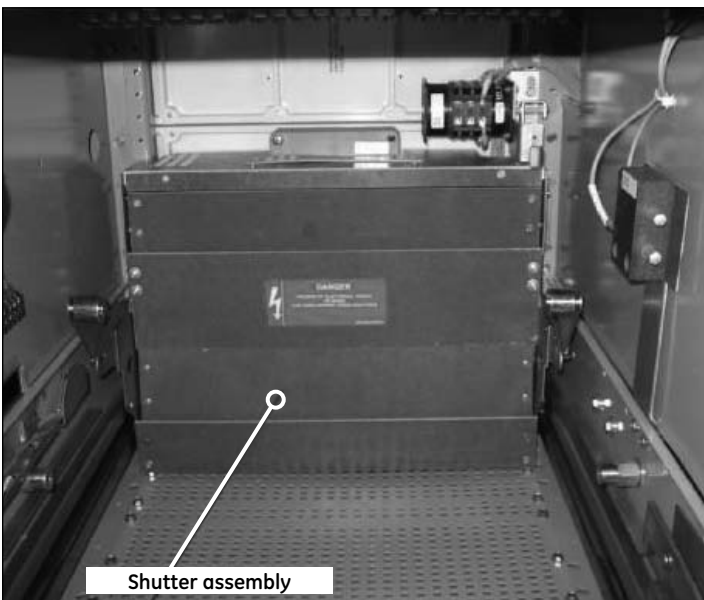
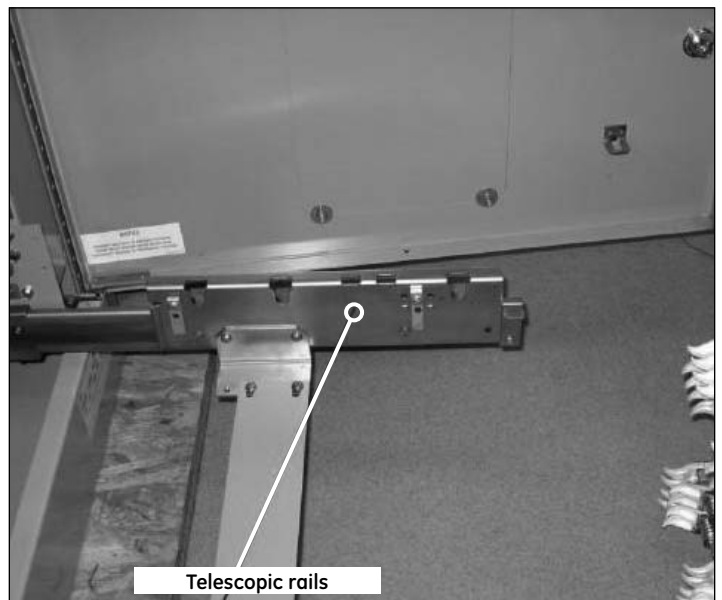

Figure 8. AKD-8 Compartment, Telescopic Rails



## Neutral Rogowski Current Transformer (CT)

The EntelliGuard R Circuit Breaker uses an air-core, Rogowski current-sensor to measure current level instead of an iron-core style used in the legacy AK, AKR breakers. For the retrofit to calculate the current levels on a 4-wire circuit with ground-fault, the neutral iron-core CT in the cable compartment needs to be replaced with a Rogowski-style CT. Rogowski CTs produce a safe low-voltage output; the Rogowski has no circuit loading or saturation problems; and there are no misalignment and open secondary windings to be concerned about. There are three Rogowski sizes, depending upon type of gear and breaker installed in the switchgear, each with multiple current ratings.

The Rogowski Transformer outputs an AC voltage level proportional to the rate of change of primary current to the Electronic Trip Unit (ETU) of the EntelliGuard R Circuit Breaker. The Rogowski coils are used with an electronic integrator circuit to yield an output voltage proportional to the primary current. The Rogowski sensor delivers a nominal output voltage at 100% of rated current.

The current transformer comes with the CT-mounted on copper bars matching the same hole-pattern as the existing neutral bar. The external neutral Rogowski mounting kit comes with three mounting brackets, two fixing screws, two cable ties, one 2m (78.75 inches) long twisted-pair extension lead and one neutral Rogowski coil. Retrofills can be used in the following ground fault applications:

- Single-source feeder breakers, 3-wire or 4-wire
- Single-source main circuit breakers, 3-wire or 4-wire

**Note:** When multi-sources are present and ground-fault detection on the trip unit is desired, then an external GF summing CT scheme must be implemented. This applies to Main-Tie-Main systems, or systems with a main source and then a back-fed generator source. Please contact the factory for more information on how to apply EntelliGuard R breakers in multi-source, ground fault scenarios.

### Ordering Info

Before ordering a neutral Rogowski, make sure you know which Rogowski device is appropriate for replacing the original iron-core CT. Start with what type of switchgear you have. For example: first determine if the switchgear is an AKD-5, AKD-6, or an AKD-8. Find out what legacy breaker is, or was, installed in the switchgear compartment. Depending on what switchgear you have, and what kind of legacy breaker is installed, and the current sensor rating of the desired retrofit, you can determine a suitable Rogowski replacement by referring to [Table 3](#).

The left columns (shaded) of the table supply specific data on legacy iron-core assemblies and point out the switchgear that would contain these assemblies. The first and second column displays the catalog number of the existing iron-core CT and where it is used. Moreover, look for an identifying label that appears on the iron-core CT, located in your switchgear. A legacy iron-core photo is featured in [Figure 9](#). The iron-core label, showing part number and range of ampere ratings, is typical of what you would see on any legacy iron-core CT ([Figure 10](#)). In this particular example, the part number displayed is **139C4970G163**. Referring to the mechanical drawing of the original iron-core CT helps you identify your legacy CT. The following drawings are the original and can be consulted for identifying your legacy iron-core CT. These illustrations are presented next:

- DWG 4 displays the assembly dimensions for the original AK25 iron-core, neutral sensor ([Page 21](#)).
- DWG 5 displays the assembly dimensions for the original AK75 and 100 iron-core, neutral sensor ([Page 21](#)).
- DWG 6 displays the assembly dimensions for the original AKR iron-core, neutral sensor ([Page 22](#)).
- DWG 7 displays assembly dimensions for the original AKR neutral, iron-core sensor (MicroVersaTrip 9) ([Page 22](#)).
- DWG 8 displays assembly dimensions for the original AKR neutral, iron-core sensor (SST) ([Page 22](#)).

The right side (un-shaded area) of [Table 3](#) helps identify the proper neutral CT replacement; that is, knowing the legacy CT Catalog number, what switchgear it is used in, the retrofit current sensor rating, and whether it had a

2-, 3-, or 4-hole pattern (right-most column). Replacement Rogowski CTs can be ordered by part numbers. In [Table 3](#) (un-shaded areas) are the Rogowski part numbers that can be associated, or matched up, with their ampere ratings, identified in column headings (right half of table). Their hole-patterns would be the same hole-patterns as the legacy CTs. The Rogowski ASM drawing numbers (indicating figure numbers) are found in the same cells as the Rogowski part numbers. The Rogowski exploded assembly drawings show CT component details and follow the table.

**Figure 9. Iron-Core CT, Legacy Assembly**     **Figure 10. Iron-Core ID Label**



**Table 3. Rogowski Assemblies Parts (Compartment Side)**

Available Amperages for Legacy AK with SST Trip Unit-Series Cable compartment CT					Amperage range available for Retrofills	Available Amperages for Retrofill EntelliGuard ACB Cable Compartment CT								
Legacy Compartment Catalog No.	Used In	Amperage	Legacy Programmer Type	Legacy Outline Drawing No.		400A	600A	800A	1000A	1200A	1600A	Hole pattern		
139C4475G1	AK-15	70-225A	SST (Note that SST trips beyond service life.)	139C4476	Not Applicable	Not Applicable					Not Applicable			
139C4475G2	AK-25	200-600A			400-600A	10108212G1 ASM 10108212 See Figure 11	10108212G2 ASM 10108212 See Figure 11	Not Applicable				2 - Hole		
343L650G13	AK-50	300-800A		568B220	800-1600A	Not Applicable	Not Applicable	10108216G3 ASM 10108216 See Figure 13	10108216G4 ASM 10108216 See Figure 13	10108216G5 ASM 10108216 See Figure 13	10108216G6 ASM 10108216 See Figure 13	4 - Hole		
343L650G14		600-1600A												
343L650G28		800-2000A												
343L671G61	AK-75	1200-3000A		568B227	Contact Factory							4-Hole		
343L671G62	AK-100	1600-4000A												
343L671G63	AK-??????	1600-4000A												

Available Amperages for Legacy AK with MVT Trip Unit-Series Cable compartment CT					Amperage range available for Retrofills	Available Amperages for Retrofill EntelliGuard ACB Cable Compartment CT												
Legacy Compartment Catalog No.	Used In (AKD-6)	Amperage	Legacy Programmer Type	Legacy Outline Drawing No.		400A	600A	800A	1000A	1200A	160A	Hole pattern						
TSVG225BK	AK-15	70-225A	MVT	139C4476	Contact Factory						Not Applicable							
TSVG206BK	AK-25	200-600A			400-600A	10108212G1 ASM 10108212 See Figure 11	10108212G2 ASM 10108212 See Figure 11	Not Applicable				2 - Hole						
TSVG303BK	AKR30/30H AKR50/50H	100-300A		568B220	400A - 1600	10108216G1 ASM 10108216 See Figure 13	10108216G2 ASM 10108216 See Figure 13	10108216G3 ASM 10108216 See Figure 13	10108216G4 ASM 10108216 See Figure 13	10108216G5 ASM 10108216 See Figure 13	10108216G6 ASM 10108216 See Figure 13	4 - Hole						
TSVG508BK	AKR30/30H AKR50/50H	300-800A																
TSVG516BK	AKR30/30H AKR50/50H	600-1600A																
TSVG620BK	AKRT-50	800-2000A		568B227 SH1	Contact Factory							Not Applicable						
TSVG830BK	AK-75	1200-3000A																
TSVG832BK	AKR-75	1200-3000A																
TSVG940BK	AK-100	1600-4000A																



**Table 3. Rogowski Assemblies Parts (Compartment Side)- Continued**

Available Amperages for Legacy AK with MVT Trip Unit-Series Cable compartment CT				Amperage range available for Retrofills	Available Amperages for Retrofill EntelliGuard ACB Cable Compartment CT							
Legacy Compartment Catalog No.	Used In (AKD-8)	Amperage	Legacy Programmer Type		Legacy Outline Drawing No.	400A	600A	800A	1000A	1200A	1600A	Hole pattern
TSVG303B	AKR30/30H AKR50/50H	100-300A	MVT	139C5016 SH2	400-1600A	10108266G1 <i>ASM</i> 10108266 See Figure 15	10108266G2 <i>ASM</i> 10108266 See Figure 15	10108266G3 <i>ASM</i> 10108266 See Figure 15	10108266G4 <i>ASM</i> 10108266 See Figure 15	10108266G5 <i>ASM</i> 10108266 See Figure 15	10108266G6 <i>ASM</i> 10108266 See Figure 15	3 - Hole
TSVG508B	AKR30/30H AKR50/50H	300-800A										
TSVG516B	AKR30/30H AKR50/50H	600-1600A										
TSVG620B	AKRT-50	800-2000A										
TSVG832B	AKR-75	1200-3200A										
TSVG940B	AK-100	1600-4000A	139C5016 SH1	Contact Factory							Not Applicable	

**Original Iron-Core CT Drawings**

The iron-core drawings below list the types, amperes, and catalog numbers referenced in [Table 3](#), above.

**DWG 4. AK25—Original Iron Core Neutral Sensor Assembly Dimensions (4th—wire neutral sensor)**

**139C4476**

SST Current Sensors/4 <sup>th</sup> -Wire Neutral Sensors		
BREAKER TYPE	AMPERE	CATALOG NO.
SST	70 TO 225	343L692G67
MicroVersaTrip		
AK-15		
AK-25	200 TO 600	343L692G68
SST		
MicroVersaTrip	300-800	343L650G13
AK-50		
AK-50	600-1600	343L650G14
AKT-50	800-2000	343L650G28
AK-75	1200-3000	Included with
AK-100	1600-4000	Basic Kit

C/T No. (VersaTrip)	AMPS
343L671G61	1200 - 3000
343L671G62	1600 - 4000
343L671G63	1200 - 3200

**DWG 5. AK75 and AK100—Original Iron Core Neutral Sensor Assembly Dimensions**



DWG 6. AKR— Neutral Iron-Core Sensor Assembly Dimensions

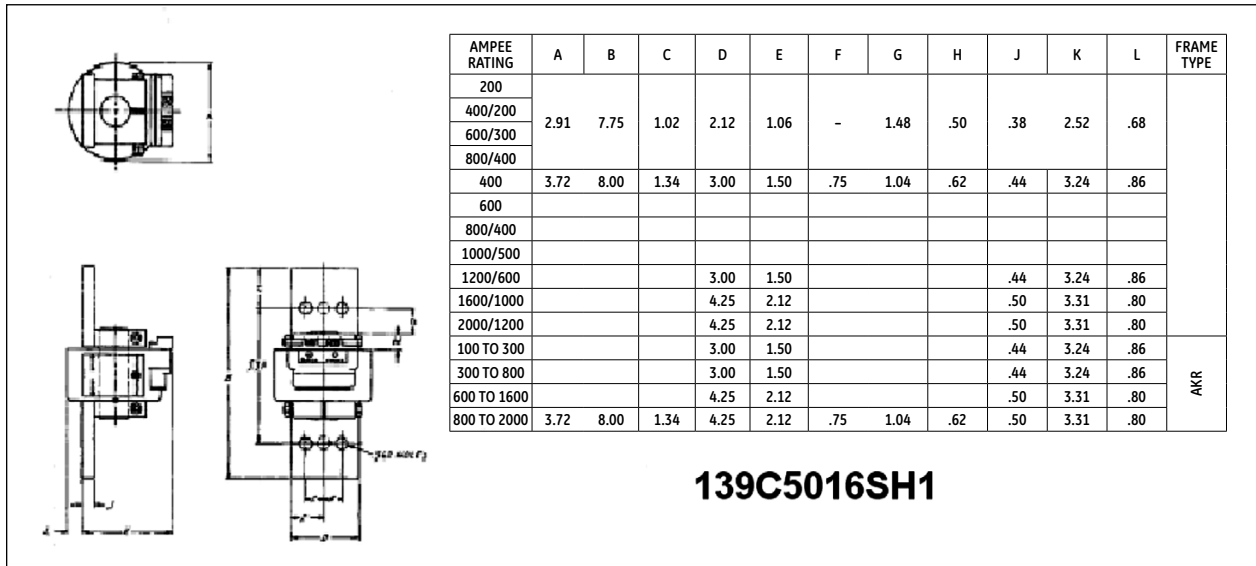

DWG 7. AKR—Original Iron-Core Neutral Sensor Assembly Dimensions (MicroVersaTrip 9)

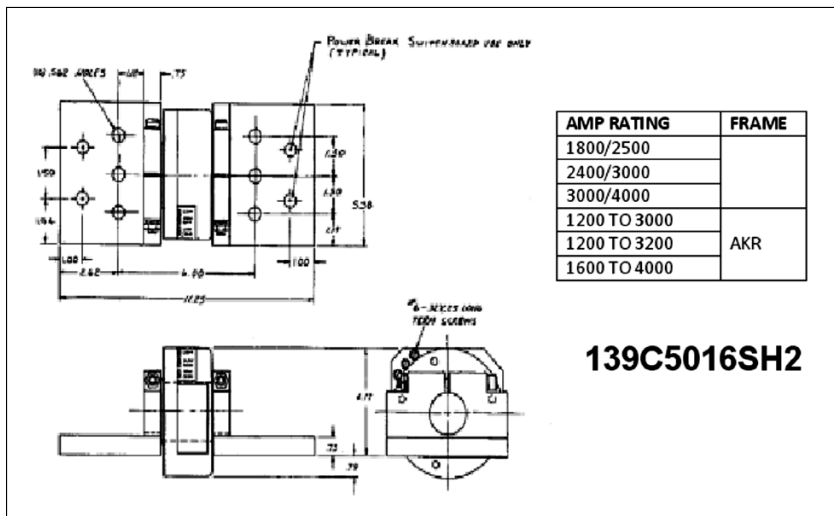

DWG 8. AKR—Original Neutral Iron-Core, Sensor Assembly Dimensions (SST)

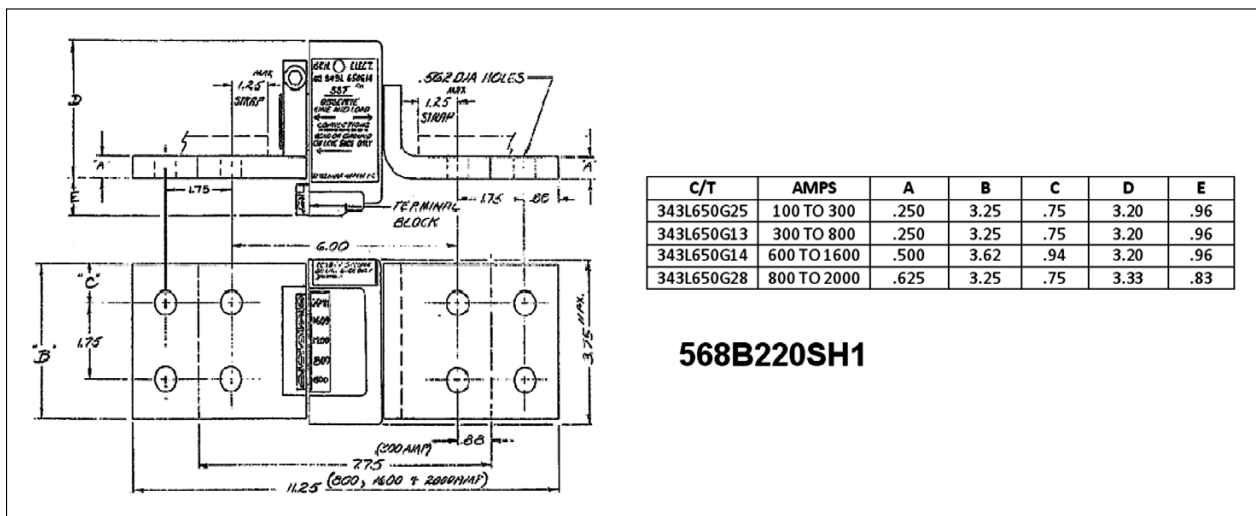

# Rogowski Neutral Bus Drawings

Replacing the legacy or original iron-cores with one of the three Rogowski CTs are referenced in [Table 3, Page 20](#)  
Shown below are Figures 11-15.

Figure 11. Neutral Bus Rogowski ASM 10108212

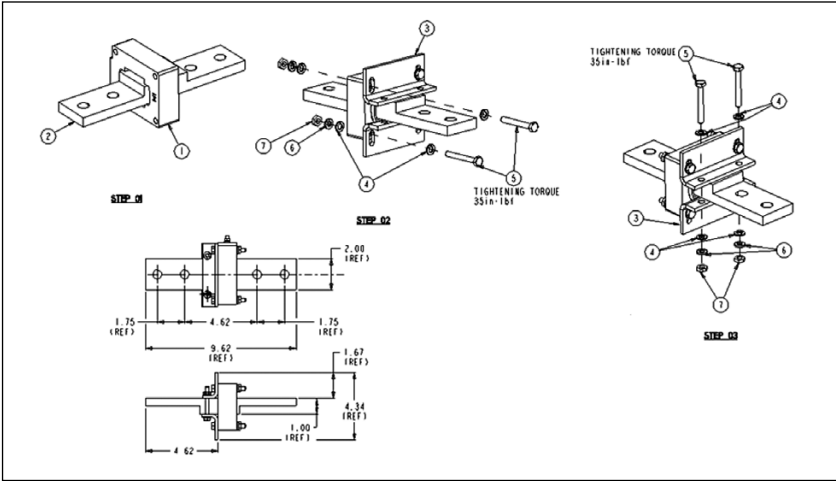

Figure 12. Neutral Bus Rogowski ASM 10108212 Photo

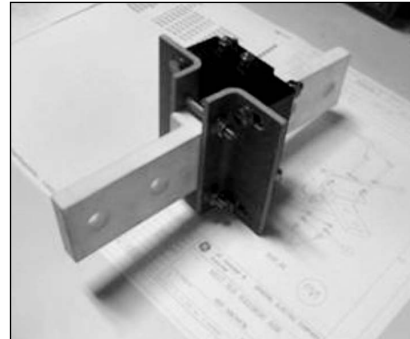

Figure 13. Neutral Bus Rogowski ASM 10108216

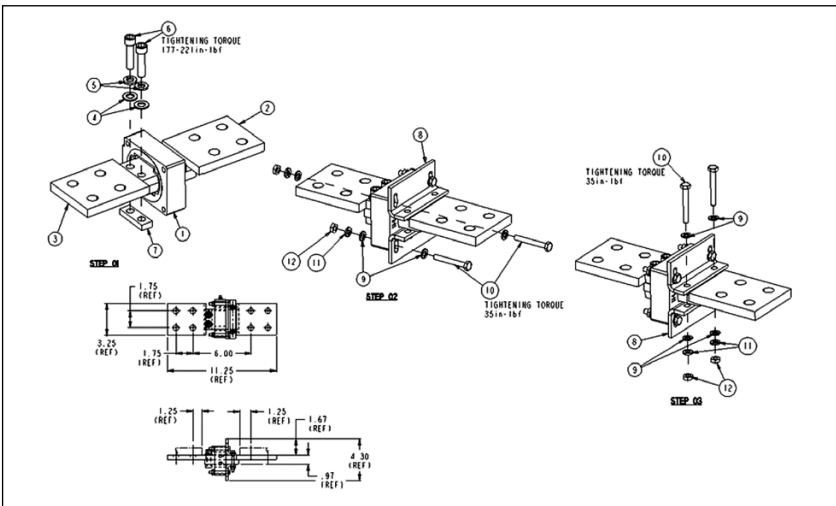

Figure 14. Neutral Bus Rogowski ASM 10108216 Photo



Figure 15. Neutral Bus Rogowski ASM 10108266

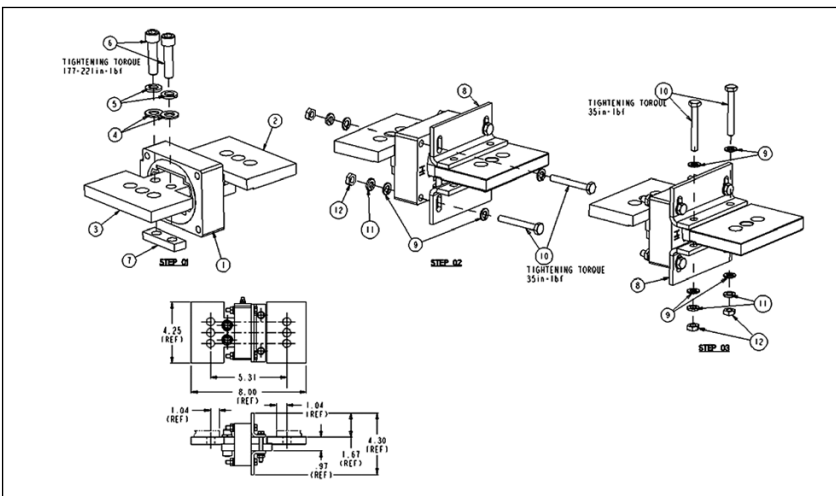
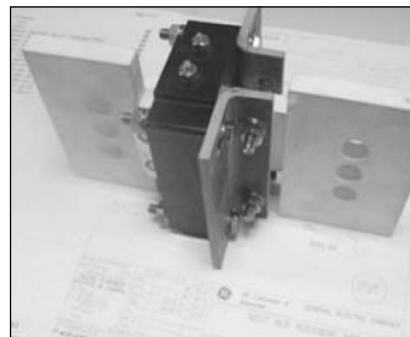

Figure 16. Neutral Bus Rogowski ASM 10108266 Photo



# Neutral Disconnect Assembly

Low voltage switchgear employ three-pole main and tie breakers in four-wire systems. There is a solid neutral running throughout the switchgear. The neutral disconnect is used to connect the breaker to the neutral CT in the cable compartment. It is designed to automatically disconnect when racking in or racking out the breaker. The neutral disconnect is mounted in the cubicle compartment. It is a block with two spring-loaded pins used to connect the breaker to the neutral CT in the cable compartment and is only needed on circuits requiring a ground fault and is a 4-wire load. A replacement is needed only if the existing device is damaged. Refer to *Note 2 in Wiring Diagram for the AK/AKR Retrofit*, Page 36.

## AKD-5 Switchgear Neutral Disconnect Assembly

On the AKD-5 the existing cubicle neutral disconnect is removed and the two wires are directly routed to the retrofit cassette after it's installed. The existing wires can be reused provided they aren't damaged and are long enough.

## Switchgear AKD-6 and AKD-8

On the AKD-6 (Figure 17) and the AKD-8 (Figure 18) and (Figure 19), the retrofit interfaces with the existing cubicle-mounted, neutral disconnect. If it is damaged or malfunctioning, a replacement block can be ordered.

If LSIG is ordered on the EntelliGuard R Retrofit breaker, the retrofit comes with the neutral disconnect interface part mounted on the breaker and is wired to the trip unit.

**Figure 17. AKD-6 AKR30H\50H Neutral Disconnect Assembly (Exploded View)**

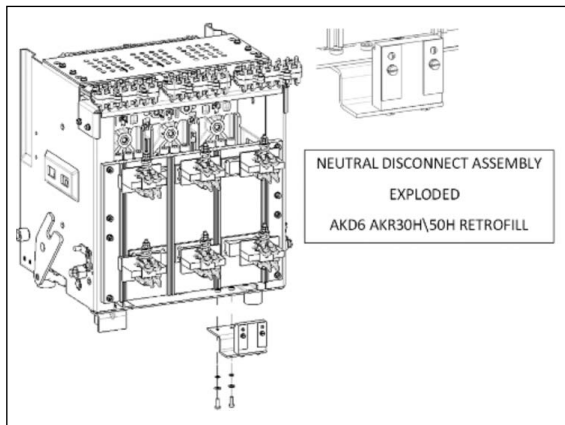

**Figure 18. Neutral Disconnect Assembly for AKD-8, AKR30H\50 H (Exploded View)**

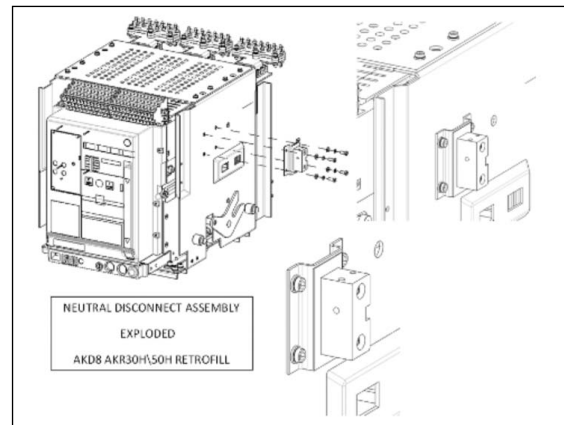

**Figure 19. Neutral Disconnect Assembly for the AKD-8, AKR30S (Exploded View)**

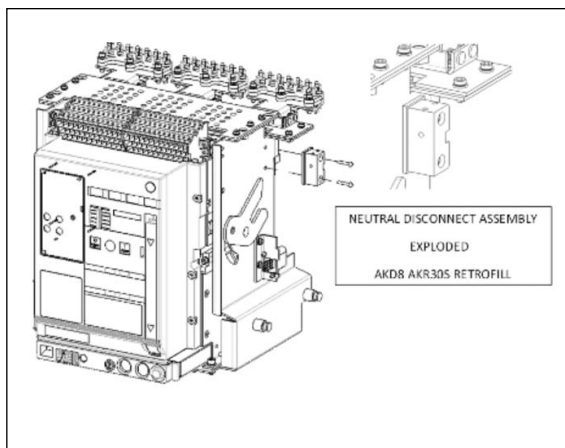

## Ordering Info

To order the neutral disconnect for your switchgear, just match the neutral disconnect part number with your switchgear (Table 4).

**Table 4. Switchgear and Neutral Disconnect Part Numbers**

Switchgear—Breaker Type	Neutral Disconnect Assembly Part Number	Neutral Disconnect Assembly
AKD-5—AK25	Wiring from compartment directly to secondaries on retrofit cassette	
AKD-5—AK/AKS 50		
AKD-8—AKR30/30H/30H/30L/50/50H	10106054G1	Breaker side—neutral disconnect assembly (retrofit side) (only needed if breaker was ordered without ground fault)
AKD-8—AKR30S	10107106G1	
AKD-6—AKR30/30H/50/50H	10105292G1	
AKR AKD-8—AKR30/30H/30H/30L/50/50H	0343L0806G2	Compartment interface, neutral disconnect (LVS side)
AKD-8—AKR30S	569B243-0020	
AKD-6—AKR30/30H/50/50H	569B243-0028	

# Position Switch Actuation Assembly

## Description

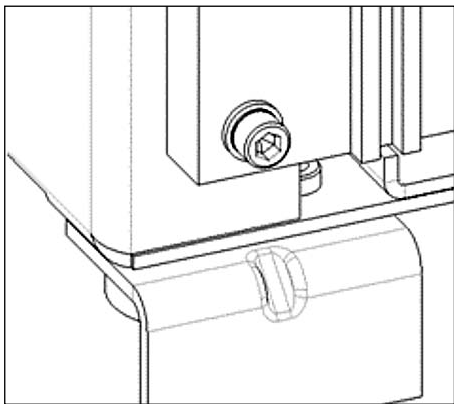

Position switches indicate the breakers racking position: connected or disconnected. EntelliGuard R interfaces with the existing position switches used by AK, AKR breakers. The legacy position switches come with a range of NO/NC options and are available for ordering if the existing positions switches are damaged or the existing cubicle doesn't have this option installed.

To interface with the existing position switch already mounted in the cubicle, some of the Retrofills require an actuation assembly added to the retrofill.

On the AKD-5, the mechanical subassembly is a simple ancillary lever-and-tension device that pushes against the position switch arm when the retrofill breaker is completely racked in. This device, mounted on the cassette using simple hardware, is called the actuator or actuator bracket. Its purpose is to

make a strong contact with the position switch when the racked-in breaker provides mechanical pressure against the arm. The mechanical force on the lever and tension mechanism then activates the position switch. The position switch, when activated, determines that the racked-in circuit breaker is connected. On AKD-6 roll-in replacements the actuation assembly is installed directly on the retrofill breaker.

To interface with the existing position switch, some breakers require a position actuation plate.

- AKD-5: AK25 and AK50 actuation—Plates are mounted on the cassette and interface with EntelliGuard R retrofill.
- AKD-6: AKR30/30H, 50/50H—Actuation plates are mounted directly on the EntelliGuard R Breaker.
- AKD-8: AKR30S/AKR50H—Position switch is operated by the back frame and no actuation assembly is required.

The breaker position switch actuator (or actuation assembly) is required for AKD-5 and AKD-6 Retrofills that have their position switches in the cubicle. The actuator is a simple mechanical device (bracket type) mounted on the breaker that presses against the position switch mechanism when the breaker is fully racked in.

Figure 20 and Figure 21 (AK25) show examples of an installed position switch for the AKD-5. It is activated mechanically when the breaker is racked in.

**Figure 20. Position Switch, an Example**

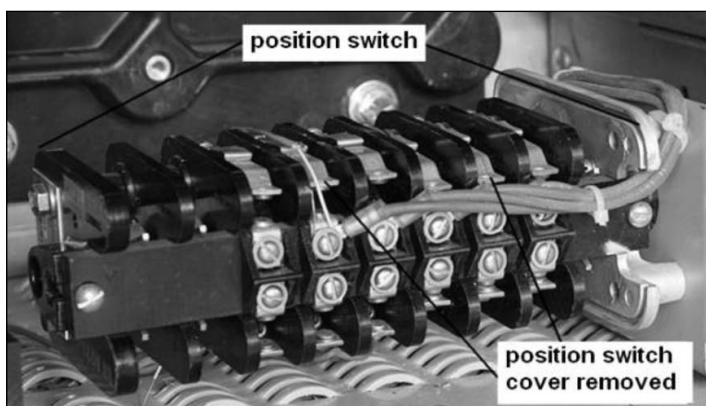

**Figure 21. AKD-5, AK25 Retrofill Breaker, Actuator for Position Switch Assembly (Exploded View)**

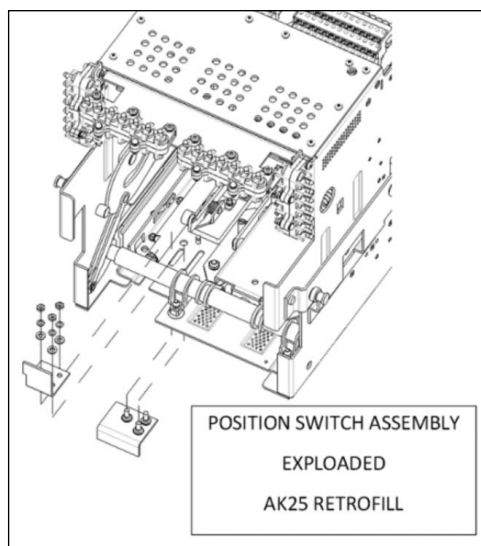

The picture to the right (above) is the AKD-5 position switch actuator bracket that is assembled with metric M6x16 screws. These metric screws are provided with the kits.

## Ordering Info

To order the position switch actuator for your switchgear, just match the position switch actuator part number with your switchgear ([Table 5](#)).

**Table 5. Ordering Position Switch Actuator Data**

Switchgear	Position SW Actuator Part Number	Position Switch Actuator Assemblies
AK/AKS 50	10106296G1	Cassette mounted—position switch actuation assembly
AK25	10106269G1	
AKD-6—AKR30/30H/30H/50/50H	10106480G1	Breaker mounted—position switch activator assembly
AKD-8—AKR30S	0343L881	Legacy position switch mounted in Compartment
AKD-8—AKR30/30H/30H/30L/50/50H	0343L690G1	
AKD-6/AKD-5	0673D0500-411	

## Secondary Wiring Disconnects

The current carrying path of a circuit breaker is known as the primary disconnects and is where the finger clusters are mounted. Secondary disconnects are used for the control wiring and automatically engage/disengage during the racking in/out of a breaker. Secondary wiring is used for items such as: motor operators, close coils, auxiliary contacts, Modbus, 24-Vdc, voltage conditioners, shunt trips, etc. Any device that is either used to control the breaker or provide feedback out of the breaker is wired through the secondary-disconnect.

Retrofills use two types of secondary-wiring-disconnects:

- Secondary disconnect blocks, also known as bullets. These are the original secondary disconnect blocks used on the legacy AK, AKR breaker and interface with the existing cubicles wiring. The block comes in sets of 7-wiring points. In the AKD-5, they are mounted on the retrofill cassette, and in AKD-6/8, they are mounted on the EntelliGuard R Retrofill Breaker.
- Programmer disconnects—advanced options on the trip unit. If any advanced option is ordered, a programmer disconnect is required to provide the 24-Vdc wiring point, Modbus communications, voltage conditioner source, zone selective interlocking, RELT, or any application of the input/output relays. This is wired at the factory. Programmer disconnects are available in 12-Pin or 19-Pin formats on the AKD-6 and AKD-8. AKD-5 does not need a programmer disconnect, as these wiring points are landed directly on the AKD-5 cassette after it is installed.

### Secondary Disconnects: 7-Bullet Blocks

Secondary disconnects can be ordered with the retrofill breaker (AKD-6/8) or on the Retrofill Cassette (AKD-5). Consulting the [EntelliGuard R ANSI Retrofill CB Catalog Number Guide on Page 9](#), notice that the 6th character indicates the option selected and can either be “none”, “A, B, C”, or “A, B, C, D”. Where “A,B,C” indicates that three sets of 7-bullet blocks are mounted on the breaker/cassette, for a total of 21 secondary points, “A,B,C,D” indicate 4 sets of 7-bullet blocks for a total of 28 points (AK25 cassette only). If only the A-Block is desired, then the “none” option can be selected on the retrofill breaker/cassette and a separate 7-bullet secondary disconnect block kit can be ordered and mounted in the field.

The 7-bullet disconnect is used for motor operators, shunt trips, UVRs, auxiliary contacts, and other non-trip unit related devices. In addition to 7-bullet disconnects, GE also offers replacement cubicle-mounted, mating secondary-disconnect plates.

## Ordering Info

To order the secondary disconnect for your switchgear (if needed), just match the secondary disconnect part number with your switchgear ([Table 7](#)). Note that secondary disconnects can be ordered assembled on your retrofill breaker/cassette.



**Table 7. Ordering Info for Secondary Disconnects Assemblies**

Switchgear	Secondary Disconnect Assembly	Secondary Disconnect Assemblies
AKD-5	386A110G2	7-Bullet Block secondary disconnect assembly AK (mounted on cassette)
AKD-6/AKD-8	10105366G1	7-Bullet Block secondary disconnect assembly AKR (mounted on breaker)
AKD-5/AKD-6/AKD-8	0176D7926G1	Compartment secondary disconnect interface—single plate (LVS side)
AKD-5/AKD-6/AKD-8	75C149315G7	Compartment secondary disconnect assembly—3 plates (LVS side)

**AKD-5/6/8—Secondary Disconnects Wiring**

The wiring harness for the secondary disconnects, located on the AKD-5 retrofill cassette, has 21 wire connections grouped in three blocks (A, B, C) for AK50 or 28-wire connections grouped in 4 blocks (A, B, C, D) for AK25, with seven wire connections for each block. Each wire is clearly labeled, or identified, with wire markers or tags. Each wire on the 21-wire harness is connected to a bullet. Each bullet, when the cassette is racked in, engages with its respective point in the switchgear. The wires for Block-A are identified as A1, A2,...A7. Block-B wiring is likewise labeled as B1, B2, B3,...B7. Block-C contains C1, C2,...C7. The end, opposite the bullets, maps or connects to the retrofill EntelliGuard R Cassette 78-point, secondary-disconnect. For example, if bullets A1 and A4 are reserved for the motor, they connect to points A1 and A2 on the cassette’s 78-point, secondary-disconnect for a motor. Each breaker needs to be landed in the field based on the specific breaker’s wiring diagram and modifications are made in the field.

Additional wire markers, cable ties, spade terminals, and sticky pads are provided. Refer to the AK wiring scheme (Figure 22) and land the wires on the EG-fixed secondary-disconnects. Wires are cut to size and crimped with the terminal lugs, provided with wire markers. Harness by cable ties is completed and overhang of wires checked. Similar to AK25 and AK50 AKD-5 breakers, AKD-6/8 roll-in replacements use similar wire harnesses from AKR secondaries and are mounted on the breaker instead of on the cassette. For further information on blocks and secondary-disconnect-bullets, refer to [Wiring Diagram for the AK/AKR Retrofill, Page 35](#).

**Figure 22. Example Wiring Diagram for AK25 Secondary Disconnects and Photo Example**

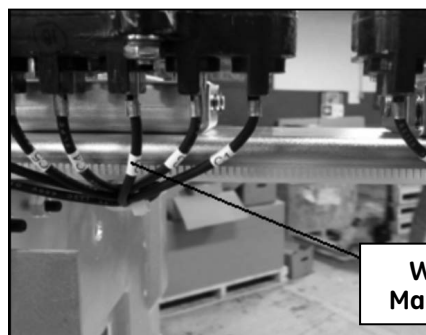
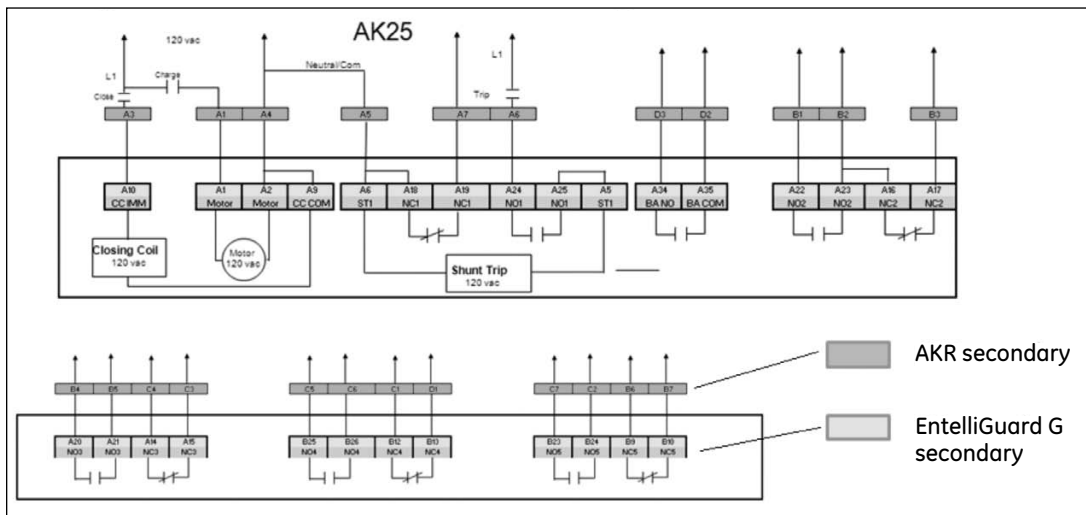

**Wire Markers**

Below is a photo showing a typical wiring harness for a retrofill where the wire harness is left with extra length for wiring with EntelliGuard secondary blocks; the other shows that the wire harness is completed with EntelliGuard secondaries (Figure 23).

Figure 23. AKD-6 Retrofill with Wiring

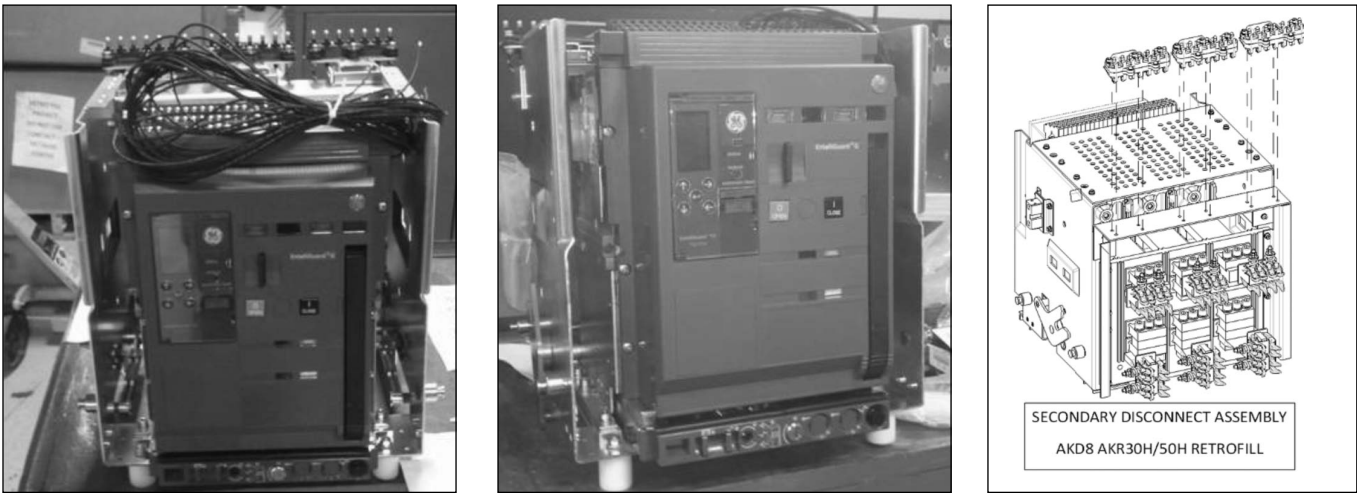

See Figure 24 for the exploded viewed of the secondary disconnect assembly for the AKD-6, AKR 30H/50H.

Figure 24. Secondary Disconnect Assembly for the AKD-6, AKR 30H/50H

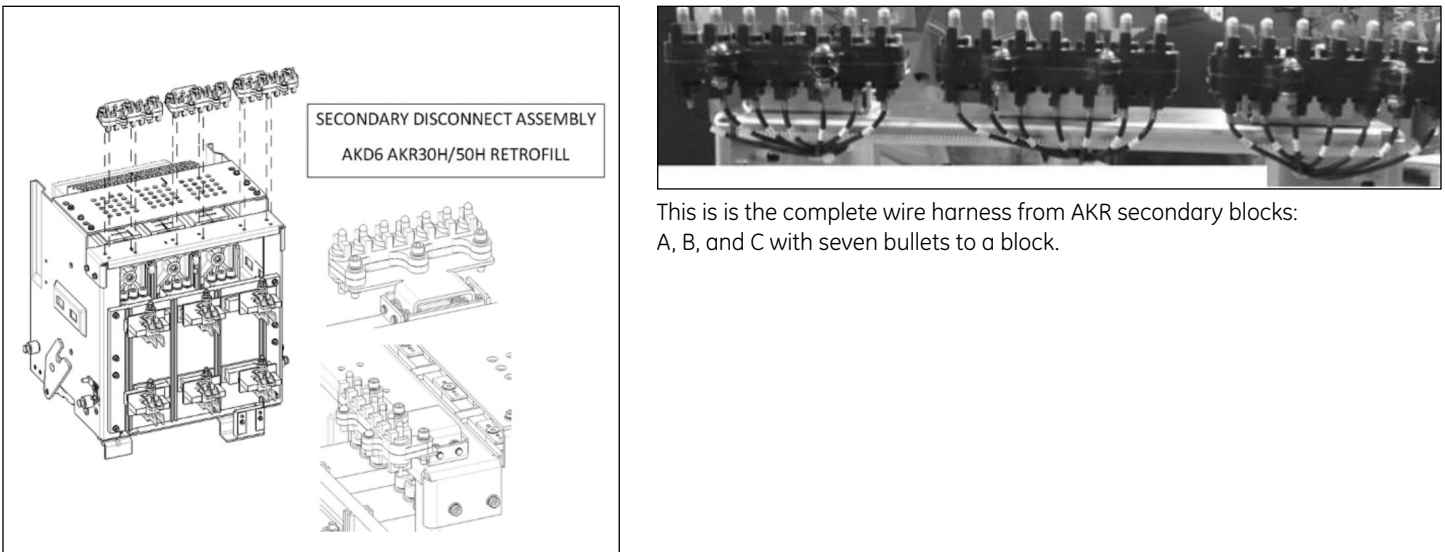

This is the complete wire harness from AKR secondary blocks: A, B, and C with seven bullets to a block.



Figure 25 shows a close-up of AK50 cassette secondary C-block, B-block, and C-block wire connections.

Figure 25. AKS50 Wire Harness and Accessories

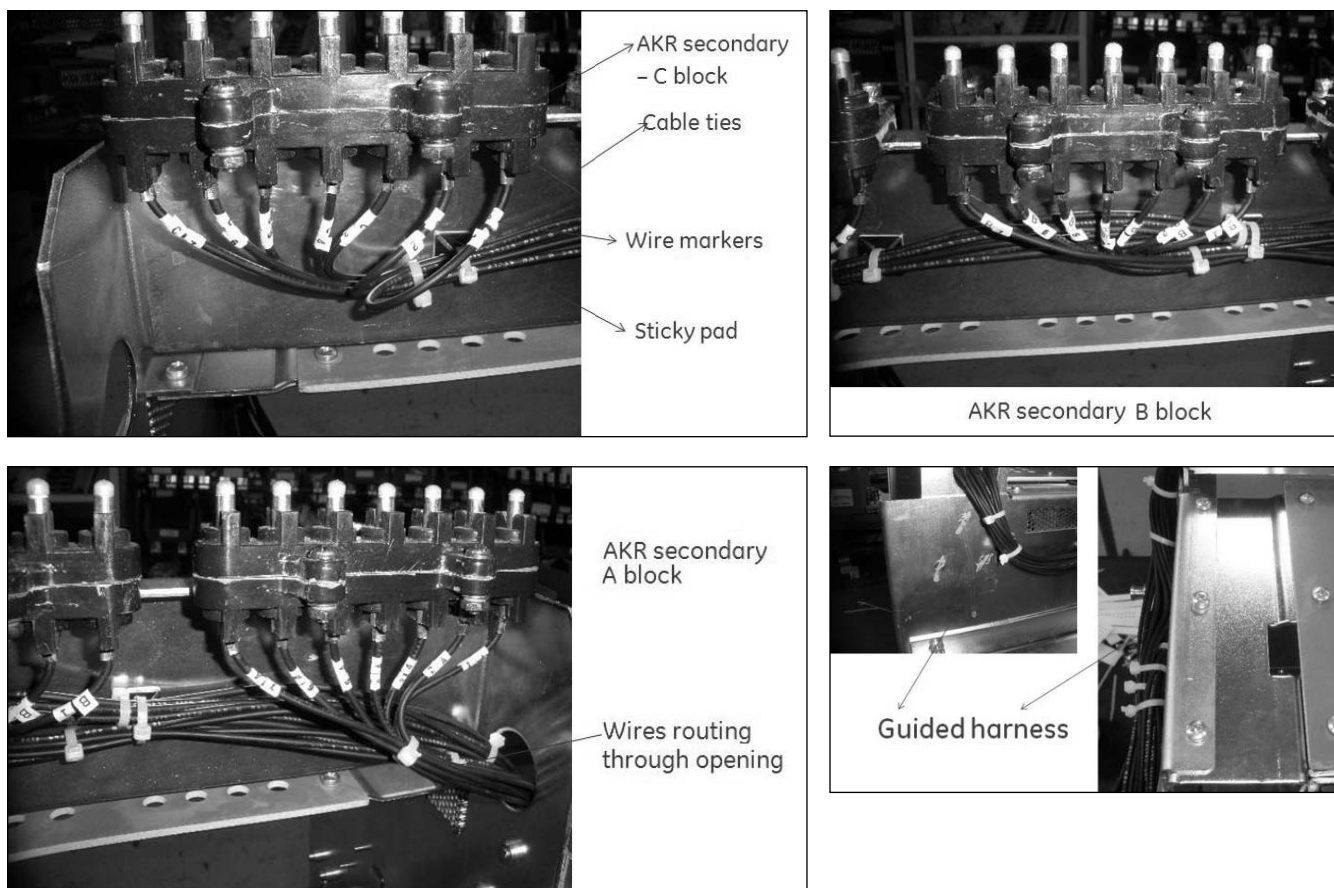

### Programmer Disconnects (12- & 19-Pin)

Introduced earlier in this section, the programmer disconnect is used for all advanced options. Similar to the legacy 9-, 12-, and 24-pin programmer disconnects used on legacy breakers, the EntelliGuard R Retrofill is available with the 19-pin programmer disconnect, used in Power Break I Circuit Breakers. This disconnect is a robust self-aligning assembly and has been proven to be a rugged design through the years. The 12-pin programmer disconnect is available if the existing installation has it installed. The [Table 8](#) below illustrates the options by gear and breaker type.

Table 8. Legacy Switchgear Programmer Disconnect Pins

Legacy Gear/Breaker	Legacy Compartment Programmer Disconnect Installed	Replacement/Addition Options
AKD-5 – AK25, AK50	None, 9-Pin, 24-Pin	Not needed, wiring is direct to cassettes secondary disconnect
AKD-6 – AKR 30/30H/50/50H	Legacy AKD6 compartments are not provided with programmer assemblies.	
AKD-8 – AKR 30/30H/30L/30S/50/50H	None, 9-Pin, 12-Pin, 24-Pin	12-Pin or 19-Pin

If the existing cubicle does not have a programmer disconnect, a 19-pin is ordered on the Retrofill and then a separate order is placed for the cubicle side programmer disconnect. Nine-pin or 24-pin programmer disconnects are replaced/rewired with a 19-pin programmer disconnect during installation of the retrofill. If the existing cubicle has a 12-pin programmer disconnect (AKD-8), then order the retrofill with a 12-pin disconnect, or if desired, it can be replaced with a 19-pin disconnect.

Here's the wiring for the 12- and 19-pin programmer showing where each advanced feature is wired from the programmer disconnect to the EntelliGuard R's 78-point secondary disconnect (*Figure 26*).

**Figure 26. Wiring Diagram for Programmer 12-Pin/19-Pin**

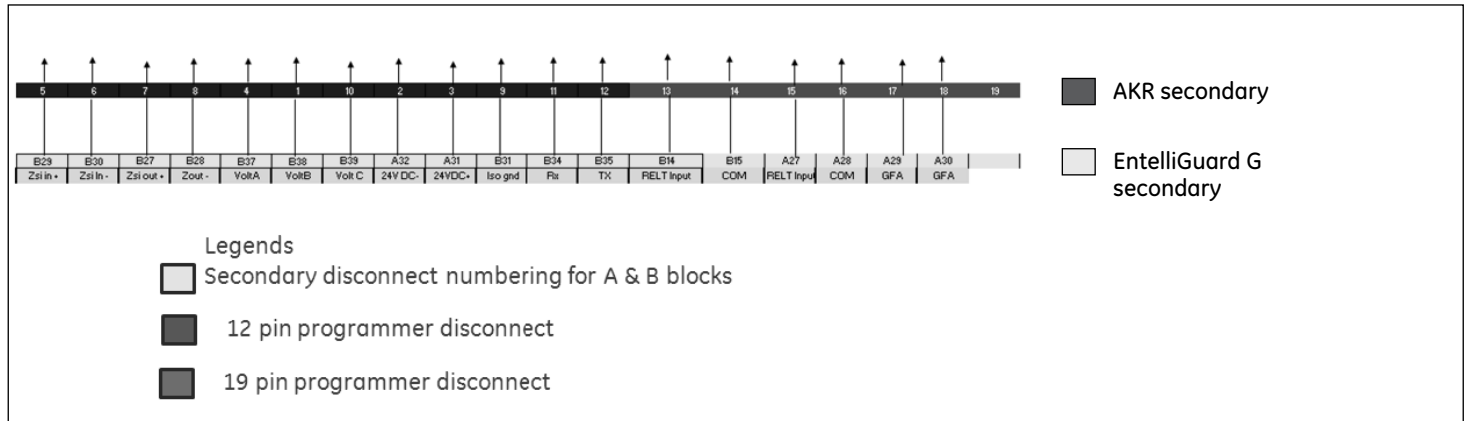

**Note:** AKD-5 does not use a programmer disconnects, the AKD-6 has only the 19-pin. The 12-pin is for the AKD-8 only.

Pin #	Feature
1	ZSI In +
2	ZSI In -
3	ZSI Out +
4	ZSI Out -
5	VoltA
6	VoltB
7	VoltC
8	24Vdc-
9	24Vdc+
10	Iso Grnd

Pin #	Feature
11	Rx
12	Tx
13	Input 1 (RELT Input)
14	Input 1 Common (RELT Input)
15	Output 1 (If RELT Optioned, Dedicated to RELT)
16	Output 1 Common (If RELT Optioned, Dedicated to RELT)
17	Output 2 (GFA, Current Alarm, Health, etc.)
18	Output 2 Common (GFA, Current Alarm, Health, etc.)
19	Open

## 19-Pin Programmer Disconnect (AKD-6, AKD-8)

*Figure 27* and *Figure 28* illustrate examples of 19-pin programmer disconnects.

**Figure 27. AKD-6 AKR30H\50H 19-Pin Disconnect Assembly (Exploded View)**

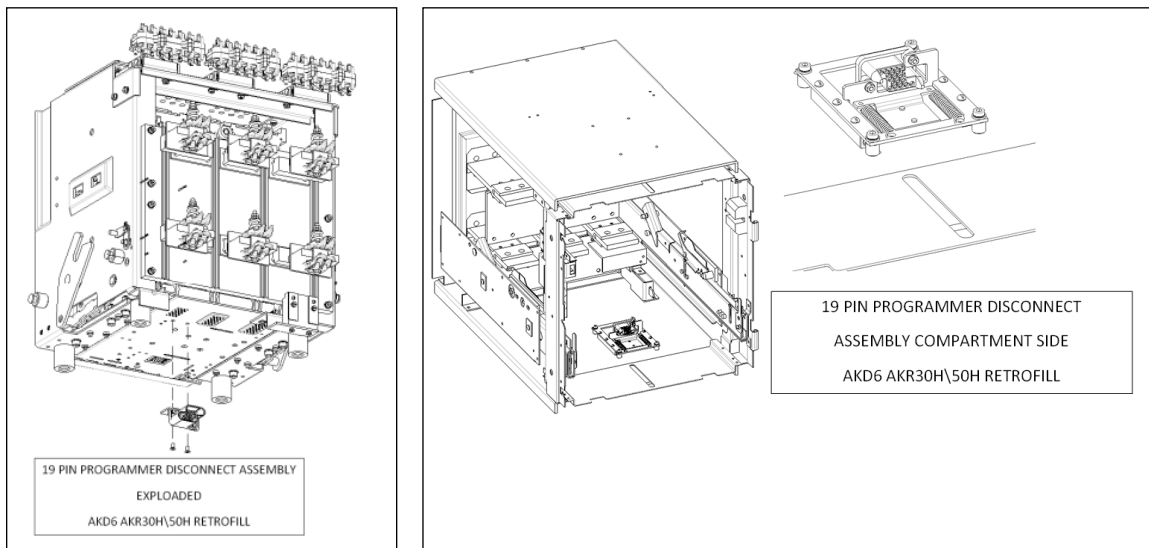

Figure 28. AKD-8 AKR30H\50H 19-Pin Disconnect Assembly (Exploded View)

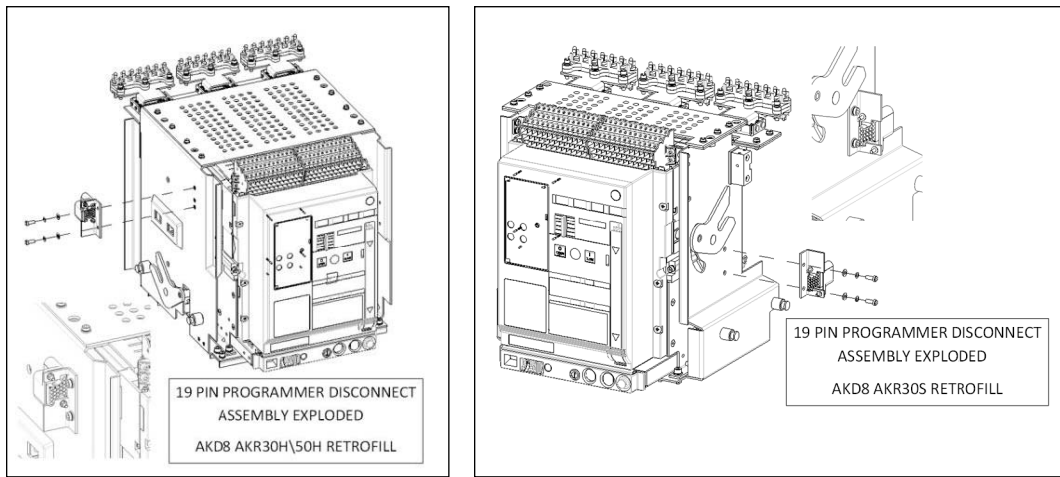

Figure 29 and Figure 30 show photos of the 19-pin disconnect for AKD-6 (breaker side and compartment side).

Figure 29. AKD-6 AKR30H\50H—19-Pin Disconnect Assembly (Breaker Side)

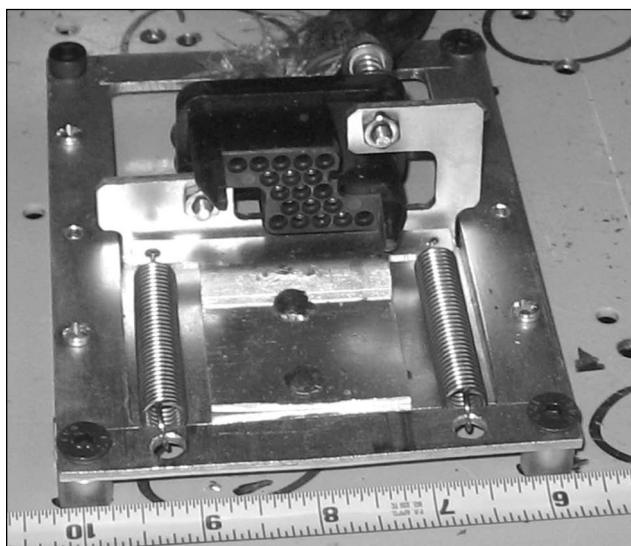
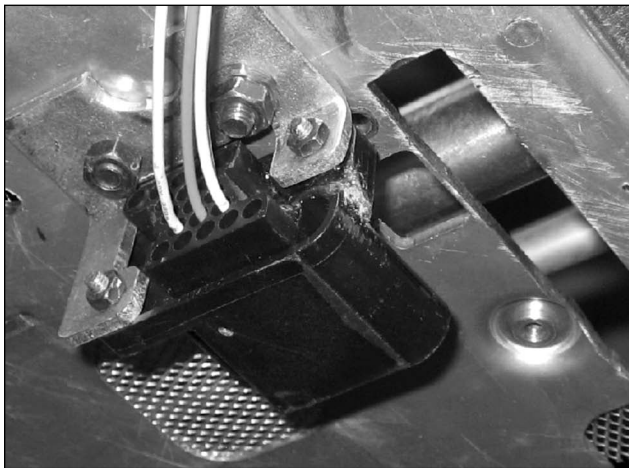

Figure 30. AKD-6 AKR30H\50H—19-Pin Disconnect Assembly (Compartment Side)

## 19-Pin Programmer Disconnect Ordering Info

To order 19-pin programmer disconnect for your switchgear, just match the 19-pin programmer disconnect part number with your switchgear (Table 9): For further information on 19-pin programmer disconnects, refer to [Wiring Diagram for the AK/AKR Retrofill, Page 35](#).

**Table 9. Ordering Info for 19-Pin Secondary Programmer Disconnect**

Switchgear	19-Pin Secondary Programmer Disconnect Part Number	19-Pin Programmer Disconnect Assembly
AKR30/30H/ 50H AKD-8	10108733G1*	Programmer disconnect assembly, 19-pin, AKD-8—breaker (retrofit side)
AKR30S	10108732G1*	Programmer disconnect assembly, 19-pin, AKR30s—breaker (retrofit side)
AKD-6	10107108G1*	Programmer disconnect assembly, 19-pin, AKD-6—breaker (retrofit side)
AKR AKD-6	10106652G1	19-pin programmer disconnect assembly—compartment (LVS side)
AKR30/30H/ 50H AKD-8	10108801G1	19-pin programmer disconnect assembly—compartment (LVS side)
AKR30S	10109176G1	19-pin programmer disconnect assembly—compartment (LVS side)

\*Order only if the retrofill selected didn't come with the 19-pin programmer disconnect.

## 12-Pin Programmer Disconnect (AKD-8)

[Figure 31](#) features the 12-pin programmer disconnect for the AKD-8 breaker.

**Figure 31. 12-Pin Programmer Disconnect for the AKD-8 Breaker**

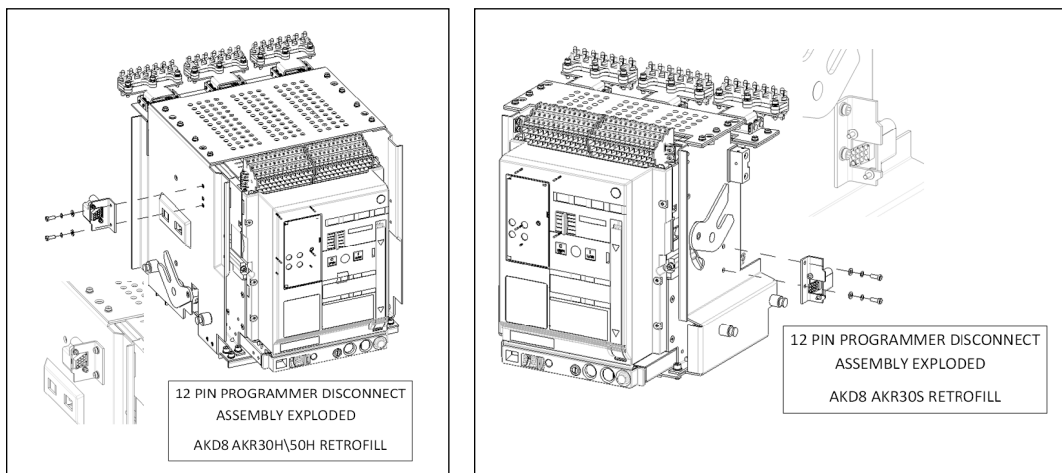
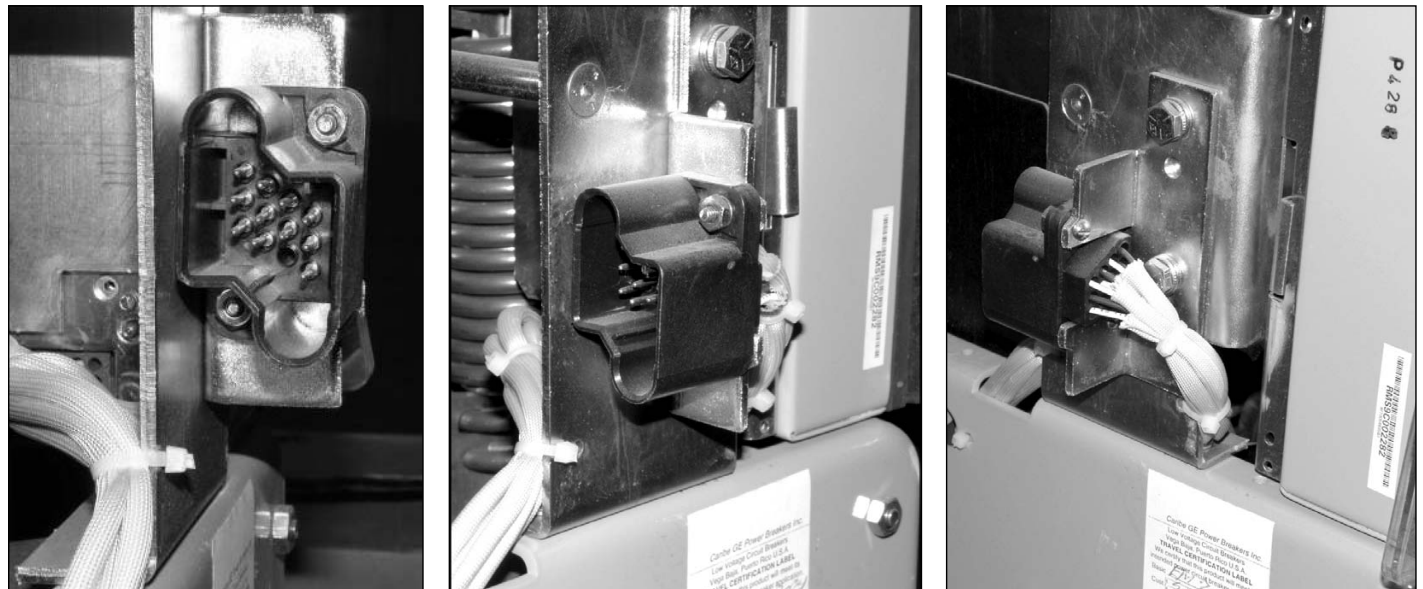
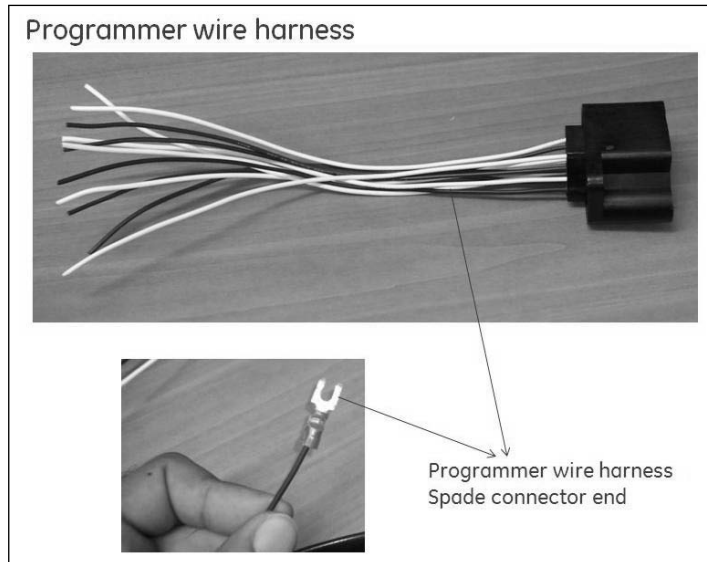



Figure 32 shows the particulars of the 12-pin wire disconnect.

**Figure 32. AKD-8 Wire Detail (12-Pin)**



### 12-Pin Programmer Disconnect Ordering Info

To order the 12-pin programmer disconnect for your switchgear, just match the 12-pin programmer disconnect part number with your switchgear (Table 10). For further information on 12-pin programmer disconnects, refer to [Wiring Diagram for the AK/AKR Retrofit, Page 35](#).

**Table 10. Ordering Info for 12-Pin Programmer Disconnect**

Switchgear	12-Pin Programmer Disconnect Part Number	Programmer Disconnect Assemblies
AKR30/30H/ 50H AKD-8	10105385G1*	Programmer disconnect assembly—12-pin, breaker (retrofit side)
AKR30S	10105651G1*	Programmer disconnect assembly—12-pin, breaker (retrofit side)
AKR30/30H/ 50H AKD-8	343L806G99	12-pin programmer disconnect assembly—compartment (LVS side)
AKD-8—AKR30S	75C149388G018	12-pin programmer disconnect assembly—compartment (LVS side)

\*Order only if the retrofit selected didn't come with the 19-pin programmer disconnect.

## 9-Pin and 24-Pin Legacy Programmer Disconnect Details

The 9-pin and the 24-pin programmer disconnects are removed and replaced. The mechanical drawing in [Figure 33](#) shows the hardware and dimensions of a legacy 24-pin programmer secondary disconnects.

**Figure 33. Programmer 24-Pin Secondary Disconnect for the AKR 30/50**

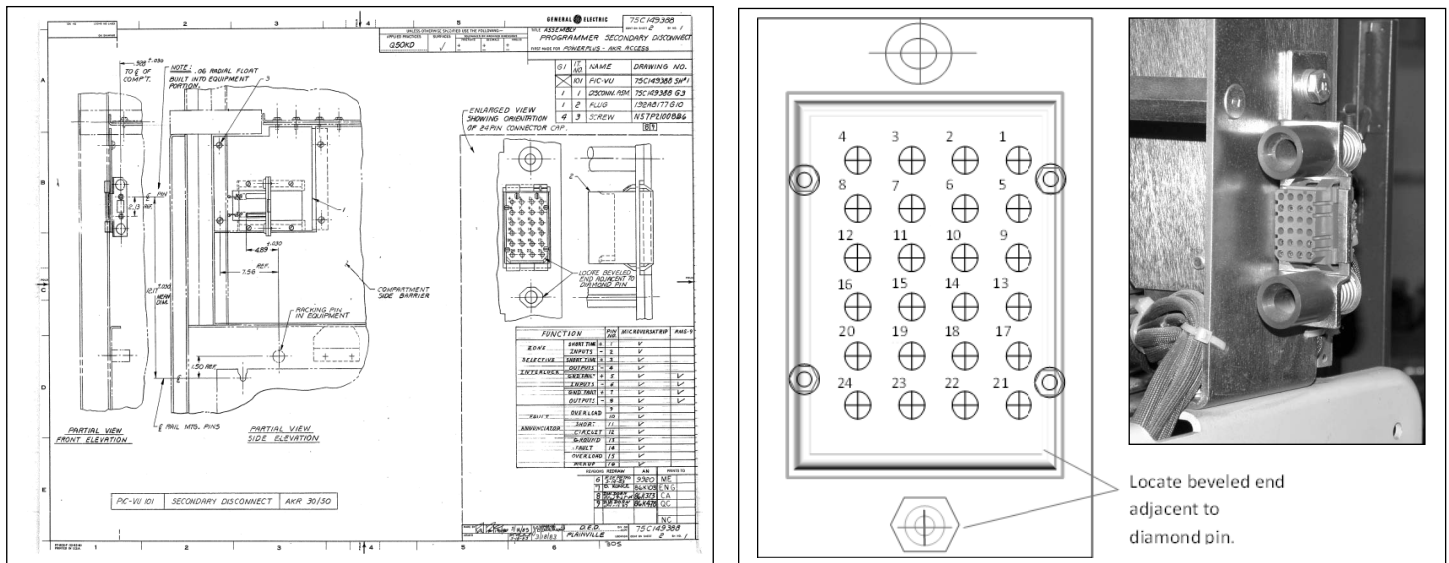

[Table 11](#) gives you the legacy 24-pin programmer disconnect wiring connections.

**Table 11. Legacy 24-Pin Wiring Data**

Disconnect Wiring				Unit Wiring		
	PIN Number	EPIC MICROVERSATRIP	T.B. Number	Wire Size		
	1	+	ZSI—Short Time Input			
	2	-	ZSI—Short Time Input			
	3	+	ZSI—Short Time Output			
	4	-	ZSI—Short Time Output			
	5	+	GND Fault Inputs	5	White	#14 Twisted Pair
6	-	6		Black		
Zone Selective Interlock	7	+	GND Fault Outputs	7	White	
	8	-		8	Black	
	17	-	Comnet	17	White	#16 Beldon
	18	+		18	Black	
	19		19	Drain Wire		
	20	VC	20	#14 Vulkene		
	21	VB	21			
	22	VA	22			
		23	+24 VRTN (Comm)	23	White	#14 Twisted Pair
		24	24 EXTRN	24	Black	

# Wiring Diagram for the AK/AKR Retrofill

**AK/AKR ... SECONDARY DISCONNECT BULLET IDS**

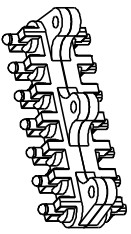

AK/AKR SECONDARY DISCONNECT BLOCK - A  
A1 A2 A3 A4 A5 A6 A7

AK/AKR SECONDARY DISCONNECT BLOCK - B  
B1 B2 B3 B4 B5 B6 B7

AK/AKR SECONDARY DISCONNECT BLOCK - C  
C1 C2 C3 C4 C5 C6 C7

SEE NOTE 1  
BLOCK - D  
D1 D2 D3 D4 D5 D6 D7

SEE NOTE 2  
NEUTRAL DISCONNECT  
1 2

PROGRAMMER DISCONNECT 10 PIN  
1 2 3 4 5 6 7 8 9 10

PROGRAMMER DISCONNECT 12 PIN  
1 2 3 4 5 6 7 8 9 10 11 12

**REVISIONS**

REV.	DESCRIPTION	DATE	APPROVED
1	R1116412	10/25/11	AJ

**NEUTRAL DISCONNECT**



**PROGRAMMER DISCONNECT 10 PIN**



**PROGRAMMER DISCONNECT 12 PIN**



**AK/AKR SECONDARY DISCONNECT ASSEMBLY**

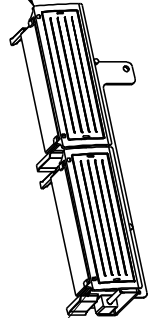

A - DISCONNECT ALWAYS PROVIDED

B - DISCONNECT

AI	A2	A3	A4	A5	A6	A7	A8	A9	A10	A11	A12	A13
MOTOR	MOTOR	Spr NO/ RTC NO	ST1	ST1	ST1	UV1	UV1	CC COM	CC IMM	CC CHD	ST2/UV2	ST2/UV2
A14	A15	A16	A17	A18	A19	A20	A21	A22	A23	A24	A25	A26
NC3	NC3	NC2	NC2	NC1	NC1	NO3	NO3	NO2	NO2	NO1	NO1	-
A27	A28	A29	A30	A31	A32	A33	A34	A35	A36	A37	A38	A39
O/P1a	O/P1b	O/P2a	O/P2b	24V+	24V+	BA NC	BA NO	BA COM	N-RC-	N-RC+	Eleg-CT	Eleg-CT

BI	B2	B3	B4	B5	B6	B7	B8	B9	B10	B11	B12	B13
INPUT1	INPUT2	I/P COM	ST1 NO/ST1 COM/ NC8	ST1 NO/ST1 COM/ NC8	UV1 COM/ NC7	UV1 COM/ NC7	B19	B20	B21	B22	B23	B24
B14	B15	B16	B17	B18	B19	B20	B21	B22	B23	B24	B25	B26
BELT INPUT	COM	-	CC NO/ CC COM/ NO8	ST2 COM/ UV2 NO/ COM/ NOT	ST2 COM/ UV2 NO/ COM/ NOT	NO6	NO6	NO5	NO5	NO5	NO4	NO4
B27	B28	B29	B30	B31	B32	B33	B34	B35	B36	B37	B38	B39
ZS1 out+	ZS1 out-	ZS1 in+	ZS1 in-	ISO GND	5V ISO	TX EN I	RX	TX	GND	VO11-A	VO11-B	VO11-C

NAME OF SITE : \_\_\_\_\_

DATE : \_\_\_\_\_

NOTE:  
 1. BLOCK - D IS ONLY PROVIDED WITH AK25 SERIES BREAKER.  
 2. NEUTRAL DISCONNECT AND PROGRAMMABLE DISCONNECT ARE OPTIONAL FEATURES USED FOR AK06 AND AK08.

THIRD ANGLE PROJECTION



GENERAL ELECTRIC COMPANY  
**WIRING DIAGRAM**  
**ENTELLI GUARD G CIRCUIT BREAKER**

SIZE: DRAWING A2  
 10109762  
 REV 1



# Finger Clusters, Spares/Replacements

## Description

The primary disconnects ([Figure 34](#) and [Figure 35](#)) are flexible connections between the breaker line and load terminals and between the equipment line and load terminals. Factory-installed, all primary disconnect fingers are assembled on EntelliGuard R Retrofill circuit breakers. A finger cluster is defined as a double pair of fingers on a breaker. Finger clusters can be ordered as spares or for replacing them if they are damaged during shipping (Ordering Info, next page).

**Figure 34. Circuit Breaker Removed, Featuring Primary Disconnects “Fingers” (Contacts)**

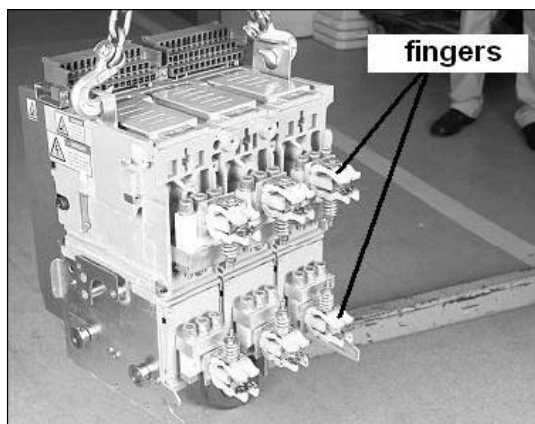

**Figure 35. Circuit Breaker, Fingers (Some Details)**

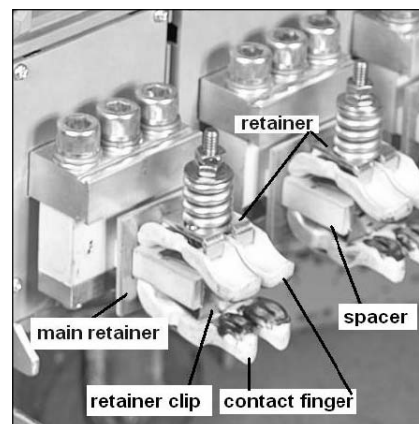

## Ordering Info

To order retrofill finger clusters for your breaker, just match the cluster part number with your breaker ([Table 12](#)):

**Table 12. Switchgear and Finger Clusters**

Switchgear	Retrofill Finger Quantity per Breaker	Cluster Part Numbers
AK25	4 x 6 = 24 per CB	10102784G1      4 Fingers
AK/AKS 50	8 x 6 = 48 per CB	10102784G2      8 Fingers
AKD-6-AKR30/30H	4 x 6 = 24 per CB	10105291G1      4 Fingers
AKD-6-AKR50/50H	8 x 6 = 48 per CB	192A9668G1      8 Fingers
AKD-8-AKR30/30H	4 x 6 = 24 per CB	10105291G1      4 Fingers
AKD-8-AKR50/50H	8 x 6 = 48 per CB	192A9668G1      8 Fingers
AKD-8-AKR30L	8 x 6 = 48 per CB (65kA)	192A9668G1      8 Fingers
AKD-8-AKR30S	4 x 6 = 24 per CB	10105967G1      4 Fingers
All SKU—Assembly Dwg.		10107842P1 (This is a 3-page factory instruction sheet requiring a special gage.)
All apply to the retrofill side		

## Shutters

Shutter components apply only to the AKD-8 Shutters for the other switchgear types (AKD-5 and AKD-6) would require a double-finger clusters design (which would generate too much heat) instead of single-clusters. To order shutters for your switchgear, just match the shutter part number with your switchgear type ([Table 13](#)).

**Table 13. Shutter and Switchgear Ordering Info**

Switchgear Type	Shutter Part Numbers	Shutter Assemblies
AKD-8—AKR30/30H/30L/50/50H	0228C8473	AKD-8 compartment shutter assembly—AKR 30/30H/30L/50/50H (LVS side)
AKD-8—AKR30S	75C149410G11	AKD-8 compartment shutter assembly—AKR 30s (LVS side)

# Door Interlock Assembly

## Description

The door interlock is used to prevent opening the cubicle door when the breaker is in the closed/on position. Door interlocks are available for all Retrofills and are ordered as separate kits. Two catalog numbers need to be ordered—one for the breaker and the other to be mounted on the door (catch plate). Refer to catalog numbers below. AKD-8 retrofill uses the existing door interlock tab for AKR30, 30L, 30H, 50, and 50H breakers. If the tab is missing, a replacement is available when ordering the door Interlock.

## Door Interlock Tab

The door interlock tab is needed only if the existing tab is missing or damaged and would apply to AKD-8 Switchgear: AKR30, 30L, 30H, 50, 50H.

## Ordering Info

To order door interlock for your switchgear, just match the door interlock part number with your switchgear ([Table 6](#)).

**Table 6. Ordering Door Interlock Assemblies**

Switchgear	Door Interlock Part Numbers	Assemblies
AKD-5	GLHDR	Door interlock mounted on Breaker
AKD-6	10108779G1	
AKD-8	75C149377	
AKD-8—AKR30/30H/30L/50/50H	75C149385P12	Door interlock tab
AKD-5—AK25	10107388P1	Door interlock catch plate mounted on the door
AKD-5—AK50	10108605P1	
AKD-6	10108404P1	
AKD-8	75C749380G6	

**Note:** AKD-5 uses the same door interlock as the Entelliguard G breaker.

# Doors

## Introduction

EntelliGuard R's through-the-door racking feature requires doors to be replaced on existing AKD-5, AKD-6, and AKD-8 switchgear. GE offers new doors for all different stack widths with three options or applications. GE retrofit doors can be:

- Punched or configured for the breaker front escutcheon only.
- Punched or configured for the (1) breaker front escutcheon and (2) holes for pilot lights (AKD-5, AKD-6). Use this option if existing pilot lights are planned to be reused, or if an option is being added, like RELT (Reduced Energy Let-Through switch).
- Punched or configured for (1) breaker front escutcheon, (2) pilot lights, and (3) ammeter/voltmeter (AKD-5, AKD-6).

Doors are shipped from the factory with all the necessary hardware, including door handles, for replacing existing switchgear doors. Doors come with rubber gasket and frame for the breaker opening. Door design limits exposure to the compartment when the door is closed. Design features also reduce the likelihood of articles or objects entering or exiting the cubicle.

**Note:** If the switchgear was built by an OEM, check that the doors match the dimensions and mounting patterns as described in the section tables that follow. If the switchgear dimensions and mounting patterns do not conform to the retrofill specifications, the OEM must provide the new or replacement doors or must be custom made.

## AKD-5, AK25 Retrofit Door Assemblies

Retrofit doors can be ordered or specified, as required, which would depend on door size and/or optional door cutouts for accommodating lamps and ammeters ([Figure 36](#) and [Figure 37](#)). Illustrations in this section show different door sizes and cutouts. [Table 17](#) displays specific door types that can be ordered by their catalog numbers, found in the table. The table also specifies those doors that can be easily modified (cutouts or punch-outs) for lamps and/or ammeters. All doors are right-hand doors.

### 20-inch Door Sizes

Figure 36. AK25 (20-inch door assembly) with and without Cutouts for Lights

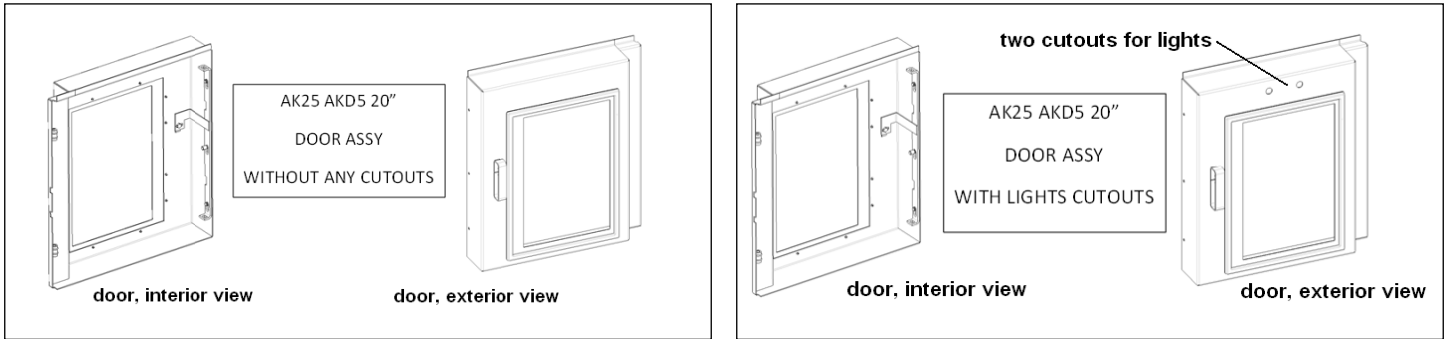

Figure 37. AK25 (20-inch door assembly) with Cutouts for Lights and Accessories



### 22-inch Door Sizes

Figure 38 displays 22-inch door assemblies, with and without cutouts for lights. The next figure, [Figure 39](#) displays cutouts for both lights and accessories.

Figure 38. AK25 (22-inch door assembly) with and without Cutouts for Lights

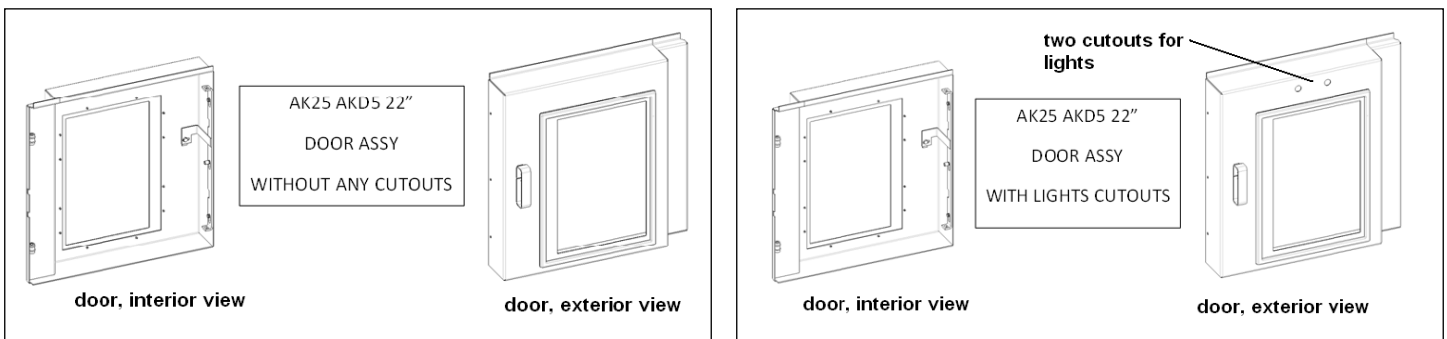

**Figure 39. AK25 (22-inch door assembly) with Cutouts for Lights and Accessories**

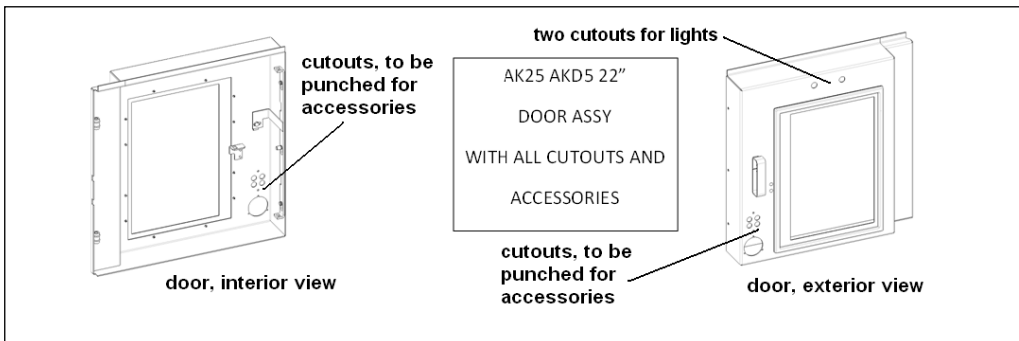

### 27-inch Door Sizes

Figure 40 displays 27-inch door assemblies, with and without cutouts for lights. The next figure, [Figure 41](#), displays cutouts for both lights and accessories.

**Figure 40. AK25 (27-inch door assembly) with and without Cutouts for Lights**

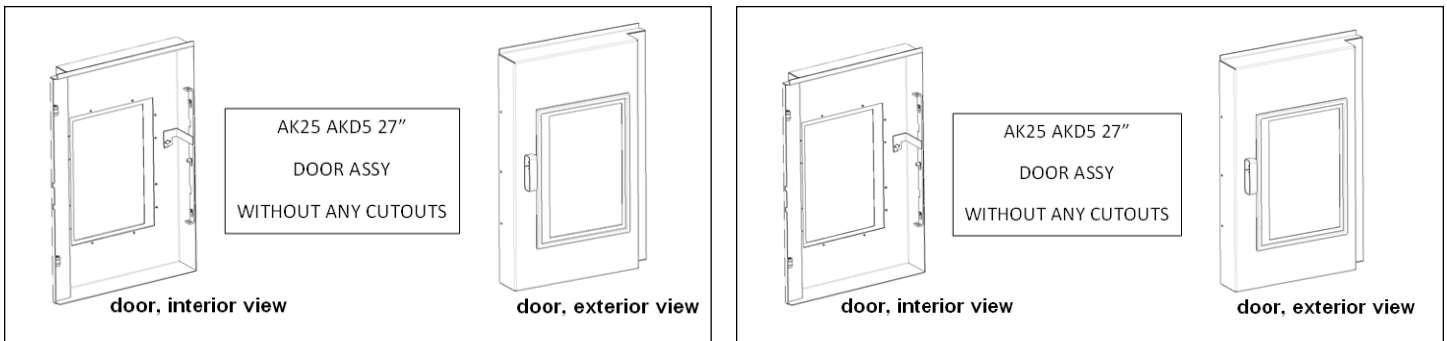

**Figure 41. AK25 (27-inch door assembly) with Cutouts for Lights and Accessories**

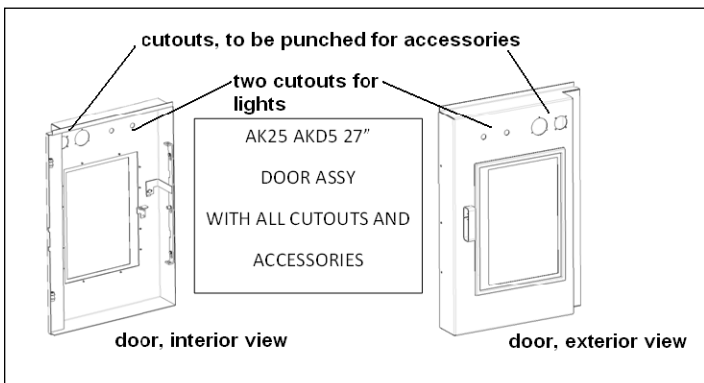

## Ordering Info

**Table 14. AKD-5 (AK25)— Replacement Door Categories (TOP LEVEL)**

Cutout Options			Available Stack Width (in inches)					Door-Swing	Door Width (in inches)	Door Bump-out (in inches)	Catalog Number
Breaker Front Escutcheon Cutout Only	Breaker Front Escutcheon and Pilot Lights Only	Breaker Front Escutcheon, Pilot Lights, and Ammeter/Voltmeter	20	22	27	30	38				
		YES			YES	YES	YES	RH	27	YES—3.7	10106255G1
	YES		YES					RH	20	YES—3.7	10107429G1
		YES		YES				RH	22	YES—3.7	10108047G1
YES			YES					RH	20	YES—3.7	10108345G1
	YES			YES				RH	22	YES—3.7	10108347G1
YES				YES				RH	22	YES—3.7	10108376G1
	YES				YES	YES	YES	RH	27	YES—3.7	10108380G1
YES					YES	YES	YES	RH	27	YES—3.7	10108383G1

### AKD-5, AK50 Retrofit Door Assemblies

Retrofit doors can be ordered or specified, as required, which would depend on door size and/or optional door cutouts for accommodating lamps and ammeters (*Figure 42* and *Figure 43*). Illustrations in this section show different door sizes and cutouts. Table 15 displays specific door types that can be ordered by their catalog numbers, found in the table. The table also specifies those doors that can be easily modified (cutouts or punch-outs) for pilot lights and/or ammeters/voltmeters. All doors are right-hand doors.

#### 27-inch Door Sizes

**Figure 42. AK50 (27-inch door assembly) with and without Cutouts for Lights**

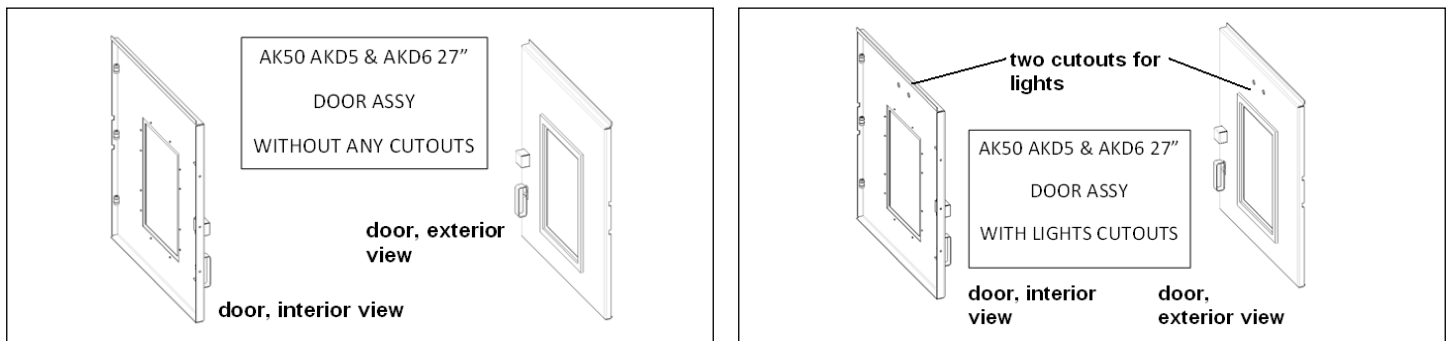
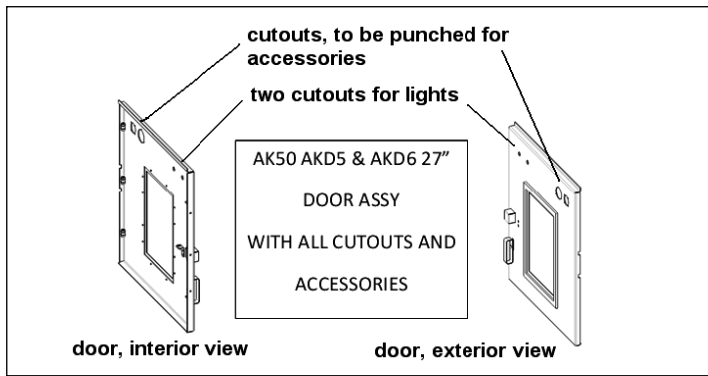

Figure 43. AK50 (27-inch door assembly) with Cutouts for Lights and Accessories



## Ordering Info

Table 15. AKD-5 (AK50)— Replacement Door Categories (TOP LEVEL)

Cutout Options			Available Stack Width (in inches)					Door-Swing	Door Width (in inches)	Door Bump-out (in inches)	Catalog Number
Breaker Front Escutcheon Cutout Only	Breaker Front Escutcheon and Pilot Lights Only	Breaker Front Escutcheon, Pilot Lights, and Ammeter/Voltmeter	20	22	27	30	38				
		YES			YES	YES	YES	RH	27	No	10106248G1
YES					YES	YES	YES	RH	27	No	10108355G1
	YES				YES	YES	YES	RH	27	No	10108363G1

## AKD-6, AKR Retrofit Door Assemblies

Retrofit doors can be ordered or specified, as required, which would depend on door size and/or optional door cutouts for accommodating lamps and ammeters (Figure 44 and Figure 45). Illustrations in this section show different door sizes and cutouts. Table 16 displays specific door types that can be ordered by their catalog numbers, found in the table. The table also specifies those doors that can be easily modified (cutouts or punch-outs) for pilot lights and/or ammeters/voltmeters. All doors are right-hand doors.

### 22-inch Door Sizes

Figure 44. AKD-6 (22-inch door assembly) with and without Cutouts for Lights

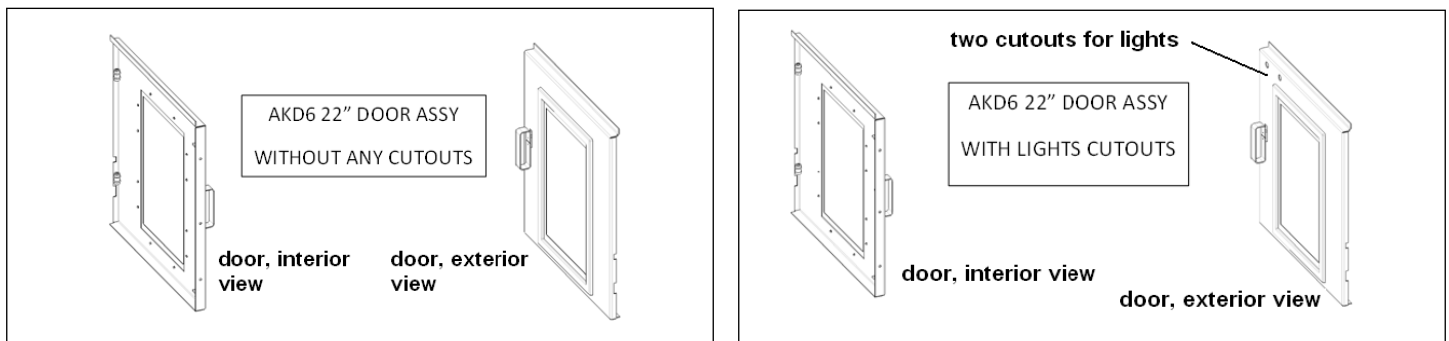



**Figure 45. AKD-6 (22-inch door assembly) with Cutouts for Lights and Accessories**

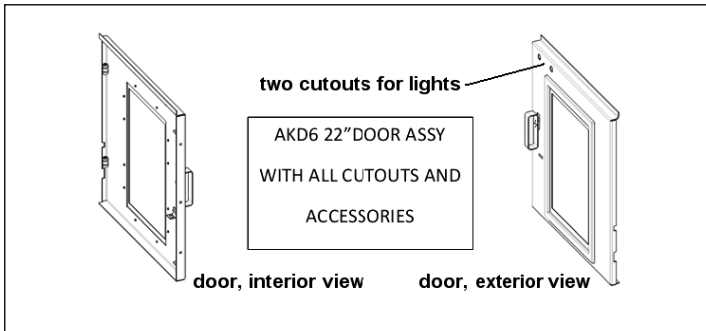

**27-inch Door Sizes**

For the AKD-6, [Figure 46](#) displays the 27-inch door assembly with and without cutouts for lights. [Figure 47](#) shows cutouts or punch-outs for the same door assembly.

**Figure 46. AKD-6 (27-inch door assembly) with and without Cutouts for Lights**

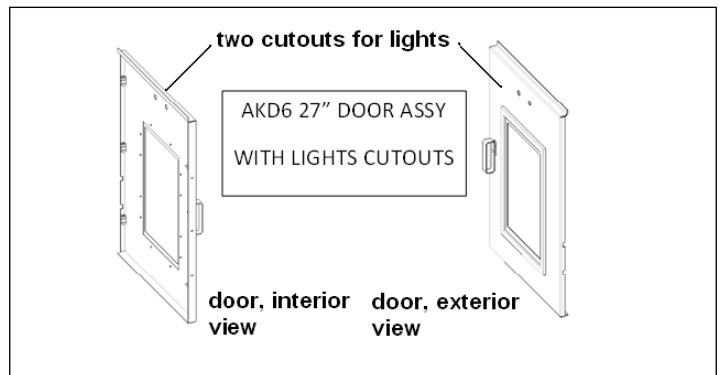
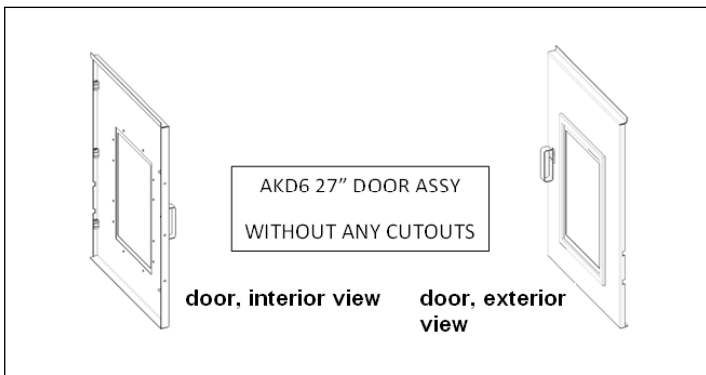

**Figure 47. AKD-6 (27-inch door assembly with Cutouts for Lights and Accessories**

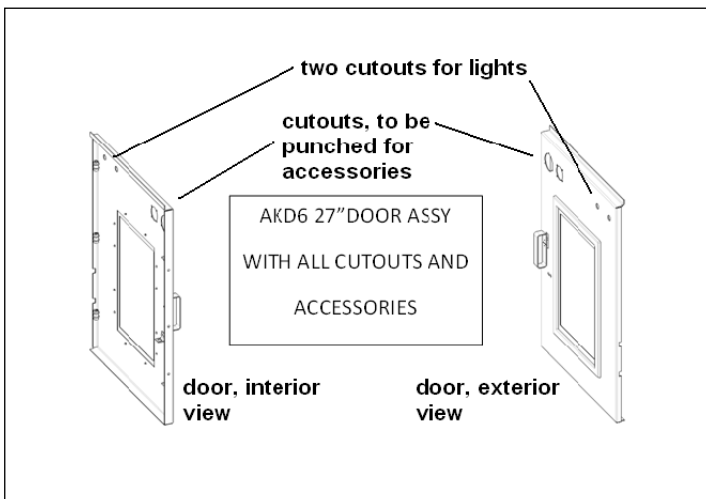

## Ordering Info

Table 16. AKD-6 (AKR)— Replacement Door Categories (TOP LEVEL)

Cutout Options			Available Stack Width (in inches)					Door-Swing	Door Width (in inches)	Door Bump-out (in inches)	Catalog Number
Breaker Front Escutcheon Only	Breaker Front Escutcheon and Pilot Lights Only	Breaker Front Escutcheon, Pilot Lights, and Ammeter/Voltmeter	20	22	27	30	38				
	YES			YES				RH	22	No	10107469G1
		YES		YES				RH	22	No	10108074G1
YES				YES				RH	22	No	10108439G1
		YES			YES	YES	YES	RH	27	No	10108447G1
YES					YES	YES	YES	RH	27	No	10108462G1
	YES				YES	YES	YES	RH	27	No	10108469G1

### AKD-8, AKR30S, AKR30H, AKR 30/50 Retrofit Door Assemblies

Retrofit doors can be ordered or specified, as required, which would depend on door size ([Figure 48](#), [Figure 49](#), and [Figure 50](#)). Illustrations in this section show different door sizes. [Table 19](#) displays specific door types that can be ordered by their Catalog numbers, found in the table. There are no cutouts for lights or accessories. All doors are right-hand doors.

#### 22-inch and 30-inch Door Sizes

Figure 48. AKD-8 (22-inch door assembly)

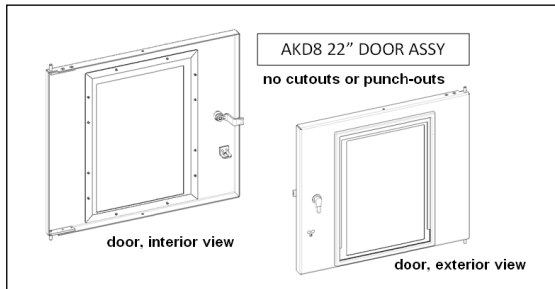

Figure 49. AKD-8 (30-inch door assembly)

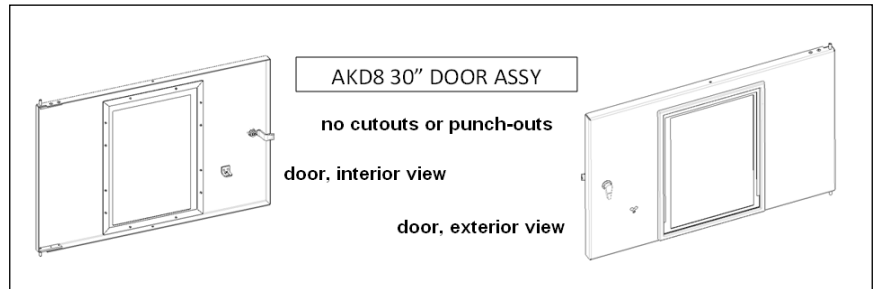
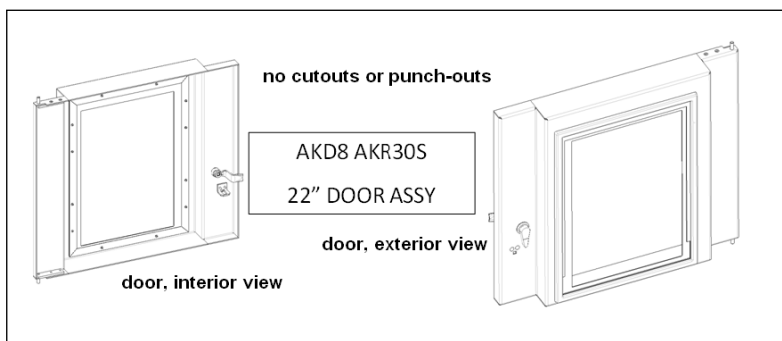

Figure 50. AKD-8 (30-inch door assembly)



## Ordering Info

**Table 17. AKD-8 (AKR)— Replacement Door Categories (TOP LEVEL)**

Cutout Options			Available Stack Width (in inches)					Door-Swing	Door Width (in inches)	Door Bump-out (in inches)	Catalog Number
Breaker Front Escutcheon Cutout Only	Breaker Front Escutcheon and Pilot Lights Only	Breaker Front Escutcheon, Pilot Lights, and Ammeter/Voltmeter	20	22	27	30	38				
YES				YES				RH	22	YES—2.95	10108089G1
YES						YES		RH	30	YES—2.95	10108090G1
YES				YES				RH	22	No	10106239G1
YES						YES		RH	30	No	10108088G1

## Retrofill Escutcheon Kit— Spare

Table 18 displays door kit options or spare parts.

**Table 18. Escutcheon Options Kit**

Description	Breaker Type	LVS	No Cutouts			No Cutouts					Catalog Number
			No Cutouts	Breaker Front Escutcheon and Pilot Lights Only	Breaker Front Escutcheon, Pilot Lights, and Ammeter/Voltmeter	20	22	27	30	38	
Retrofill Escutcheon Kit- Spare	AK25	AKD-5				YES	YES	YES	YES	YES	10109607G1
	AKR	AKD-6				N/A	YES	YES	YES	YES	
	AKR	AKD-8–AKR30S				N/A	YES	YES	YES	YES	
	AKR	AKD-8 Regular				N/A	YES	YES	YES	YES	
Escutcheon Kit Drawout	AK50	AKD-5				N/A	N/A	YES	YES	YES	10102167G1

# Labels

All EntelliGuard R Retrofill's come with the following labels to identify those cubicles that have been retrofilled. Labels are made by a thermal printing practice and use self-adhesive to secure them to both the breaker and doors.

## Labels on Breaker

The labels affixed to the breaker are these:

- Rating label: Breaker Type, Amp/AIC Ratings, UL Listed logo:
- Large label indicating the replaced legacy: breaker type, serial number, and wiring diagram:

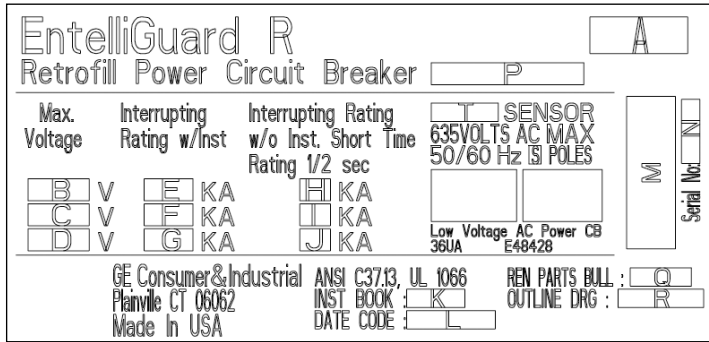

- 20-Digit breaker front escutcheon catalog number label:



## Labels on Door

The labels affixed to the breaker are these:

- Caution label indicating the cubicle has been retrofilled with an EntelliGuard R:
- Missing is Side label showing details of all the features installed on the breaker:
- Circuit name label with space for legacy type breaker and circuit name:



## Ordering Info

Missing labels can be ordered using the following Catalog numbers:

EntelliGuard R Retrofill Identification label: **10108740P1**

EntelliGuard R Retrofill Door Identification label: **10108739P1**

EntelliGuard R Retrofill Door Warning label: **10108741P1**

## Rejection Schemes for Retrofill

Similar to all drawout power circuit breakers, EntelliGuard R has a rejection feature to prevent incorrect breakers going into the wrong cell/cradle. The AKD-5 Retrofill uses the EntelliGuard G rejection feature between the breaker and EntelliGuard G cassette. On the AKD-6 and AKD-8, the retrofill has the same rejection feature type and location as the legacy AKR breaker.

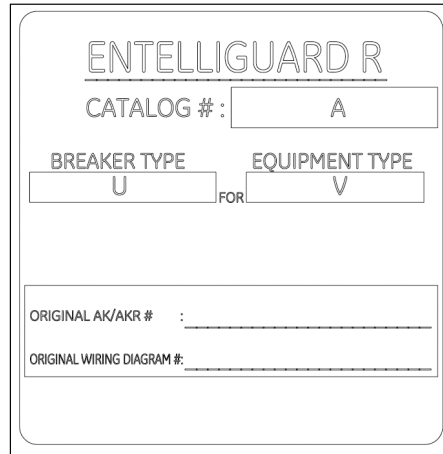

# Appendix A—Circuit Breaker History and Designations

## Chronology

Chronology of Low Voltage Switchgear	
1935	AE'S AND AL'S - OILFILM TRIP DEVICES
1936	DRAWOUT SWITCHGEAR
1938	FIRST DRAWOUT STANDARD
1941	SECOND DRAWOUT STANDARD
1946	AK-1-25 BREAKER (AKD) -EC-1 TRIP DEVICE
1947	AK-1-25 [AKD]
1948 - 1950	AK-1-50, AK-1-75, AK-1-100
MID 1950'S	AK-2 [STORED ENERGY] DESIGN
1955	EC-2 TRIP DEVICE
1960	AKD-5 SWITCHGEAR INTRODUCED (WELDED ALUM BUS)
1966	AK-3 STATIC TRIP BREAKER (POWER SENSOR)
1970	AE, AL PARTS NO LONGER AVAILABLE
1971	AKE, AKL REPLACEMENT D/O BREAKER
1977	AKD-6 SWITCHGEAR WITH AKR BREAKERS
1977	ECS, SST SOLID STATE TRIP DEVICES
1978	AKJ-50/T50 REPLACEMENT BREAKERS (repl for AK-50 in AKD-5 in 27" wide compartment)
1979	AKS-50/T50 REPLACEMENT BREAKERS (repl for AK-50 in AKD-5 in 27" wide compartment -- uses AKR-75 parts)
1980	AKD-8 SWITCHGEAR AND MVT-9 TRIP UNIT
1985	AKR-30S BREAKER
1986	RMS9 AND EPIC TRIP UNITS
1991	AKD-8 MODEL 3 REDESIGN
1993	AKD-8 WITH TIN PLATED COPPER BUS
1993	POWER LEADER PRODUCTS W/ MVT PLUS AND PM TRIP UNIT
1994	AKR-125 5000A BREAKER
1994	STACKED LARGE FRAME BREAKERS AND FUSE ROLL-OUTS
1997	5000A FUSE ROLL-OUT
1998	WAVEPRO BREAKER AND AKD-10 SWITCHGEAR
2005	ENTELLISYS SYSTEM INTRODUCED FOR HIGH END LV SWGR APPLICATIONS APPLICATIONS – Uses EntelliGuard breaker.
2008	ENTELLIGUARD TU TRIP UNIT, ARC FLASH MITIGATION AND SELECTIVITY AT THE SAME TIME
2009	ENTELLIGUARD G BREAKER 400A-6000A, 3- and 4-pole, 100% rated AND AKD-20 SWITCHGEAR
2011	ENTELLIGUARD R RETROFILL BREAKERS BASED ON THE ENTELLIGUARD G

## Power Circuit Breaker Designations

### AK/AKR

POSITION	III	V	I	II	III	IV	V	VI
AK (-) - (-) (-) - (---) (-) - (-)								

Position I	Breaker Description
AK	Old style LVPCB
AKF	Field discharge circuit breaker
AKS	Replacement for AK-50, AKJ-50
AKST	Replacement for AKT-50, AKJT-50
AKSU	Replacement for AKU-50, AKJU-50
AKR	New style LVPCB
AKRT	2000A frame LVPCB
AKRU	Integrally fused version of AKR-30S/30/50
AKU	Integrally fused version of AK-25/50

Position II	Trip Unit Type
2	EC (available on 2-pole DC breakers only)
3*	Power Sensor (sensors & power supplies available through GE - Atlanta Service Shop)
4*	ECS
5*	SST
6*	MicroVersaTrip 9
7*	MicroVersaTrip RMS9
8*	MicroVersaTrip EPIC
9*	Powerleader MVT Plus, MVT PM (4-button keypad)
10	Powerleader Enhanced MVT Plus, MVT PM (5-button keypad)
11	EntelliGuard TU
N	Non-Automatic (no trip unit)

\* Discontinued trip units. See trip unit evolution table for more information on trip units.

Position III	Breaker Application
BLANK	AK Drawout Switchgear
A	AKD-5/6 Drawout Switchgear and General Purpose Enclosures (AKR-75/100 Breakers are AKD-5 Style)
B	AKR-OEM Drawout Substructure (AKD-6 Style Drawout Breakers with Deep Escutcheon)
C	AKD-8 Drawout Switchgear
D	AKD-8 Style Drawout Breakers for AKD-8 OEM Substructures (AKR-75/75H/100 breakers in OEM Substructures not included)
F	AKR-75/75H/100 Drawout Breakers for AKD-8 OEM Substructures
S	Stationary Mounted Breakers
W	AKR-100 Stationary, 33" Wide

Position IV	Breaker Frame Size in Amperes
15	225 AC →→ N/A
25	600 AC →→ 600 DC
30S	800 AC →→ N/A
30	800 AC →→ 800 DC
30H	800 AC →→ N/A
30L	800 AC →→ N/A
50	1600 AC →→ 2000 DC
50H	1600 AC →→ N/A
T50H	2000 AC →→ N/A
75 (AK)	3000 AC →→ 4000 DC
75 (AKR)	3200 AC →→ 4000 DC
75H	3200 AC →→ N/A
100	4000 AC →→ 6000 DC
125	5000 AC →→ N/A

4000A and 6000A DC breakers are presently not available.



Position V	Rating Modifications
BLANK	Standard breaker ratings
C	AK-50 and 75 breakers having short circuit ratings similar to AK-100
D	Suffix "D" is affixed to AKR breaker designations to identify non-automatic DC models (for example AKR-NB-30D)
H	AK/AKR breaker having higher short circuit rating
	AKR-30H has 42kA SC rating (@480 Volts)
	AK-50H, AKR-50H has 65kA SC rating (@480 Volts)
	AKR-75H has 85kA SC rating (@ 480 Volts)
L	AKR-30L breaker has extended 65kA SC rating (@480 Volts)
S	Special quick close (5-cycle) for AK-50, 75, 100 only. Note: all AKR breakers are "quick close"
	AKR-30S only -- 800 amp frame breaker built on AK-25 frame. Used in AKD-8 and OEM substructures only.
Y	Special rated breakers for welding circuit duty

Position VI	Breaker Design Modifications
	Dash numbers: -1, -2, -3, etc. are used to identify specific breaker designs for renewal parts purposes:
	A dash one (-1) suffix added to the AK-25 breakers (AK-2A-25-1) identifies breakers designated for and built in Vega Baja. Non-dash one breakers were built in Farmington, CT and Philadelphia, PA.
	On March 16, 1989, a dash one (-1) suffix was added to the AKD-8 EPIC breakers and the AKD-8 RMS9 breakers with ZONE SELECTIVE INTERLOCK to reflect a design change to the trip unit secondary disconnect plug.
	EX: AKR-8D-30-1 identifies an AKD-8 breaker with the new trip unit secondary disconnect plug. A dash one breaker is not interchangeable with a non-dash one breaker.
	Breakers supplied with the Powerleader trip unit (MicroVersaTrip Plus or PM) utilize a new trip unit secondary disconnect plug and therefore do not display a dash one in the legend.
	EX: AKR-9D-30, AK-9A-25, AKR-10D-125
	Examples of full breaker designations for AK / AKR breakers:
	AKRU-10D-30 = integrally fused 800A frame breaker, for AKD-8 switchgear or OEM substructure, with MicroVersaTrip Plus or PM trip unit.
	AKR-10A-50 = 1600A frame breaker, for AKD-5 or AKD-6 switchgear, with MicroVersaTrip Plus or PM trip unit.
	<b>Note:</b> Breakers for Burlington-built switchgear are not interchangeable with OEM breakers of the same frame size and rating.

## WavePro

### Low Voltage Power Circuit Breaker Designations

WPS	WavePro breaker—standard IC (interrupting capacity)
WPH	WavePro breaker—high IC
WPX	WavePro breaker—extended IC
WPF	WavePro breaker—integrally fused (200kAIC)

-08	800A frame
-16	1600A frame
-20	2000A frame
-32	3200A frame
-40	4000A frame
-50	5000A frame

AKR-to-WavePro Cross Reference	
AKR-30	WPS-08
AKR-30S	N/A
AKR-30H	WPH-08
AKR-30L	WPX-08
AKRU-30	WPF-08
AKR-50	WPS-16
AKR-50H	WPH-16
AKRU-50	WPF-16
AKRT-50H	WPS-20
AKR-75	WPS-32
AKR-75H	WPH-32
N/A	WPX-32
AKR-100	WPS-40
N/A	WPX-40
AKR-125	WPS-50
N/A	WPX-50

WavePro Breaker Trip Unit Designations	
(From the WavePro breaker catalog number—5th digit).	
Code Letter	Trip Unit Type
A,D	MVT Plus
B,E	MVT PM (MVT M) (metering and communications)
C,F	MVT PM (metering, relaying, and communications)
G,H,J,K,L,M	Power+
N,P,Q,R,S,T,V,W,Z, 1, 2, 3, 4, 5, 6, 7, 8, 9	EntelliGuard TU
AKR to WavePro cross-reference is for frame size / interrupting rating only. Does not indicate breaker interchangeability. AKR and WavePro breakers ARE NOT interchangeable.	

## EntelliGuard

EGS	EntelliGuard breaker - standard IC (interrupting capacity)
EGH	EntelliGuard breaker - high IC
EGX	EntelliGuard breaker - extended IC
EGF	EntelliGuard breaker - integrally or separately fused (200kAIC)

-08	800A frame
-16	1600A frame
-20	2000A frame
-32	3200A frame
-40	4000A frame
-50	5000A frame

## EntelliGuard for Entellisys Switchgear compared to WavePro and EntelliGuard G

EntelliGuard breakers are available as manually operated (no shunt trip, no close coil, no-spring charging motor) or electrically operated (120Vac charge, close, and trip). All EntelliGuard breakers are provided with a 2-stage auxiliary switch, which provides breaker status to the CPU. The only accessory for EntelliGuard breakers is a bell alarm or network interlock. The network interlock is a “logic driven” device that provides mechanical interlock capabilities to the breaker. It is used where traditional electrical interlocking would be used on WavePro or AKR breakers (such as auto transfer schemes).

EntelliGuard breakers are not interchangeable with WavePro breakers due to slight differences in the secondary disconnect wiring. Rejection plates on EntelliGuard breakers allow a larger frame breaker (of equivalent or higher short circuit rating) to be used in lower ampere rated cubicles. Example: 2000A EntelliGuard breaker fits in any 800 or 1600A non-fused breaker cubicle. This makes the 2000A breaker a universal spare for 800A, 1600A, and 2000A, 65kA or lower breakers. Also, a 1600A EntelliGuard breaker can be used as a spare for an 800A EntelliGuard breaker (non-fused, same or higher short circuit rating). Similarly, the 4000A EntelliGuard breaker can be used as a spare for a 3200A breaker.

**Note:** EntelliGuard breakers are used only in GE Entellisys switchgear. They share no common parts with EntelliGuard G or EntelliGuard R breakers. They are similar to, but not interchangeable with, WavePro circuit breakers (See Figure 51).

**Figure 51. EntelliGuard Power Circuit Breakers 800–2000A Frames 240–600Vac (left view) and 3200–5000A Frames, 240 600Vac (right view)**

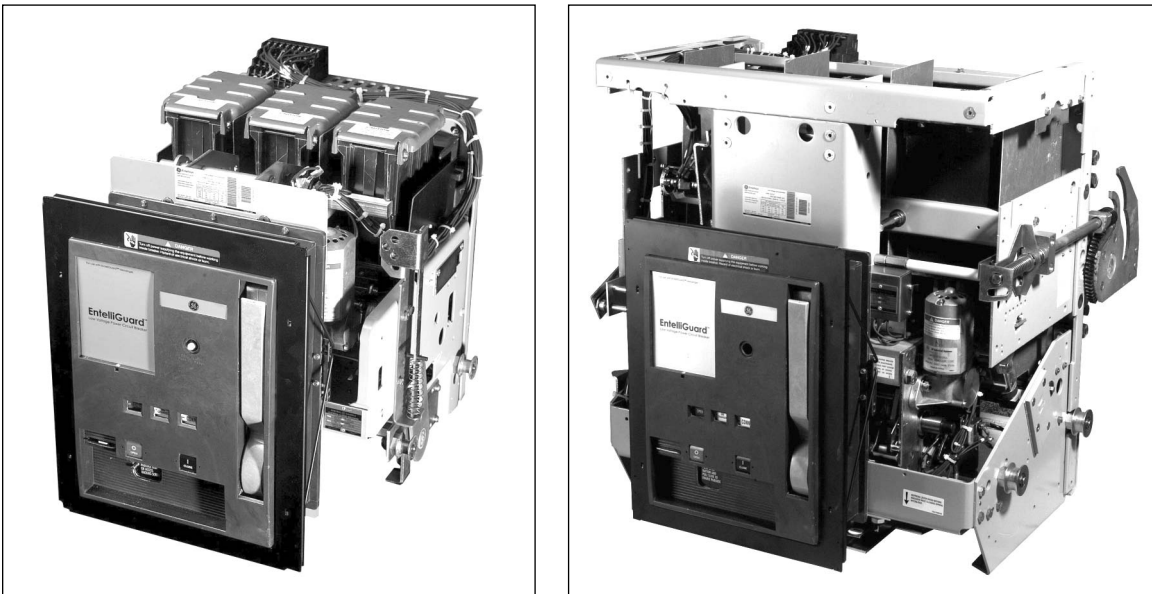



## Additional AfterMarket Solutions

- EntelliGuard TU Trip Units - Replacement trip units. Plug and Play with RMS9, MVT, EPIC, MVT+, MVT PM
- Zone Selective Interlocking – Instantaneous, Waveform Recognition Instantaneous, Reduced Energy Let-Through (RELT)
- EntelliGuard TU Conversion Kits – Upgrade your metal frame breakers trip unit.
- Power Break II retrofit into Power Break (Fixed or Drawout)
- Remote Rackers for AKR, WavePro, EntelliGuard, EntelliGuard G
- Remote Operation/Monitoring/Control and PMCS systems
- Original Equipment Manufacture AK, AKR breaker parts or new AK, AKR breakers

GE Energy  
41 Woodford Avenue  
Plainville, CT 06062  
[www.geindustrial.com](http://www.geindustrial.com)  
© 2011 GE Company



imagination at work

EntelliGuard® is a trademark of General Electric Company.

Information provided is subject to change without notice. Please verify all details with GE. All values are design or typical values when measured under laboratory conditions, and GE makes no warranty or guarantee, express or implied, that such performance will be obtained under end-use conditions.