



# Spectra RMS™ Molded-Case Circuit Breakers

## Lug Kits for Breaker Types SGD, SGH, SGL, & SGP (600 A maximum)

**WARNING:** Danger of electrical shock or injury. Turn **OFF** power ahead of the device before lug installation or modification. Do not remove circuit protective devices until the power is **OFF**.

**AVERTISSEMENT:** Danger d'électrocution. Couper l'alimentation avant d'installer les bornes ou de modifier le raccordement. Ne pas retirer l'appareil de protection avant que l'alimentation soit coupée.

### Introduction

These instructions describe the installation of TCLK365 (three-pole) and TCLK265 (two-pole) lug kits on Spectra RMS™ types SGD, SGH, SGL, and SGP circuit breakers. If cables are to be connected to both ends of the breaker, two lug kits are required. The contents of these kits are listed in Table 1.

Item	TCLK265	TCLK365
Wire terminals (lugs)	2	3
1/2-13 x 1 inch socket-head cap screws	2	3
1/2 inch I.D. lockwashers	2	3
Lug cover	1	1

Table 1. Contents of lug kits.

The following tools are required to install these lug kits:

- 5/16-inch by 3-inch-long hex bit
- 3/8-inch by 3-inch-long hex bit
- Torque wrench rated to 375 inch-pounds

The TCLK265 and TCLK365 lug kits are rated for either single or parallel conductors, as listed in Table 2.

Location	Conductors
Top hole	#8-500 kcmil Cu #8-500 kcmil Al
Bottom hole	2/0-600 kcmil Cu 2/0-600 kcmil Al

Table 2. Conductor ratings of lug kits.

### Installation

Trip the breaker by pushing the red trip button on the front of the breaker. Install the lug onto the strap, as shown in Figure 1, and secure it with a single mounting screw and lockwasher. Torque the mounting screw to 200 in-lb.

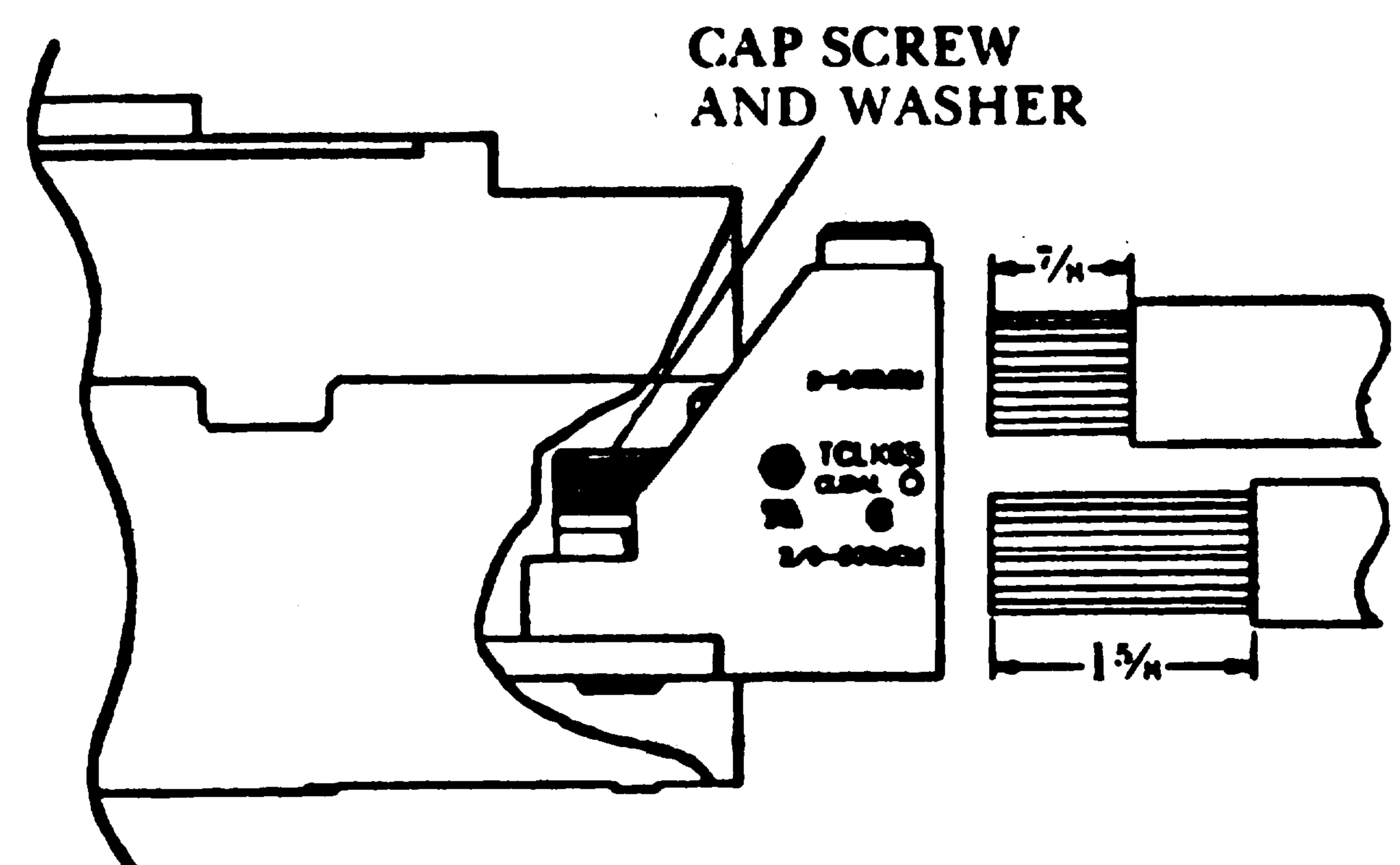

Figure 1. Lug installation on breaker.

Strip 7/8 inch of insulation from the top-hole conductor and 1 5/8 inch of insulation from the bottom-hole conductor, being careful not to nick the wire. When installing aluminum wire, use the joint compound recommended by the wire manufacturer.

Insert the wires into the lug, making sure that all strands are contained and secured under the lug screws. Torque the lug screws to the appropriate values for the wire size, as listed in Table 3.

Wire Size	Screw Torque
#8-#3	275 in-lb
#2-600 kcmil	375 in-lb

Table 3. Torque values for lug screws.

Install the lug cover supplied with the kit as shown in Figure 2. Although the cover is retained by a friction fit, two #6 x 1/2-inch thread-cutting, flat-head screws (not supplied) may be used in the provided holes to secure the cover.

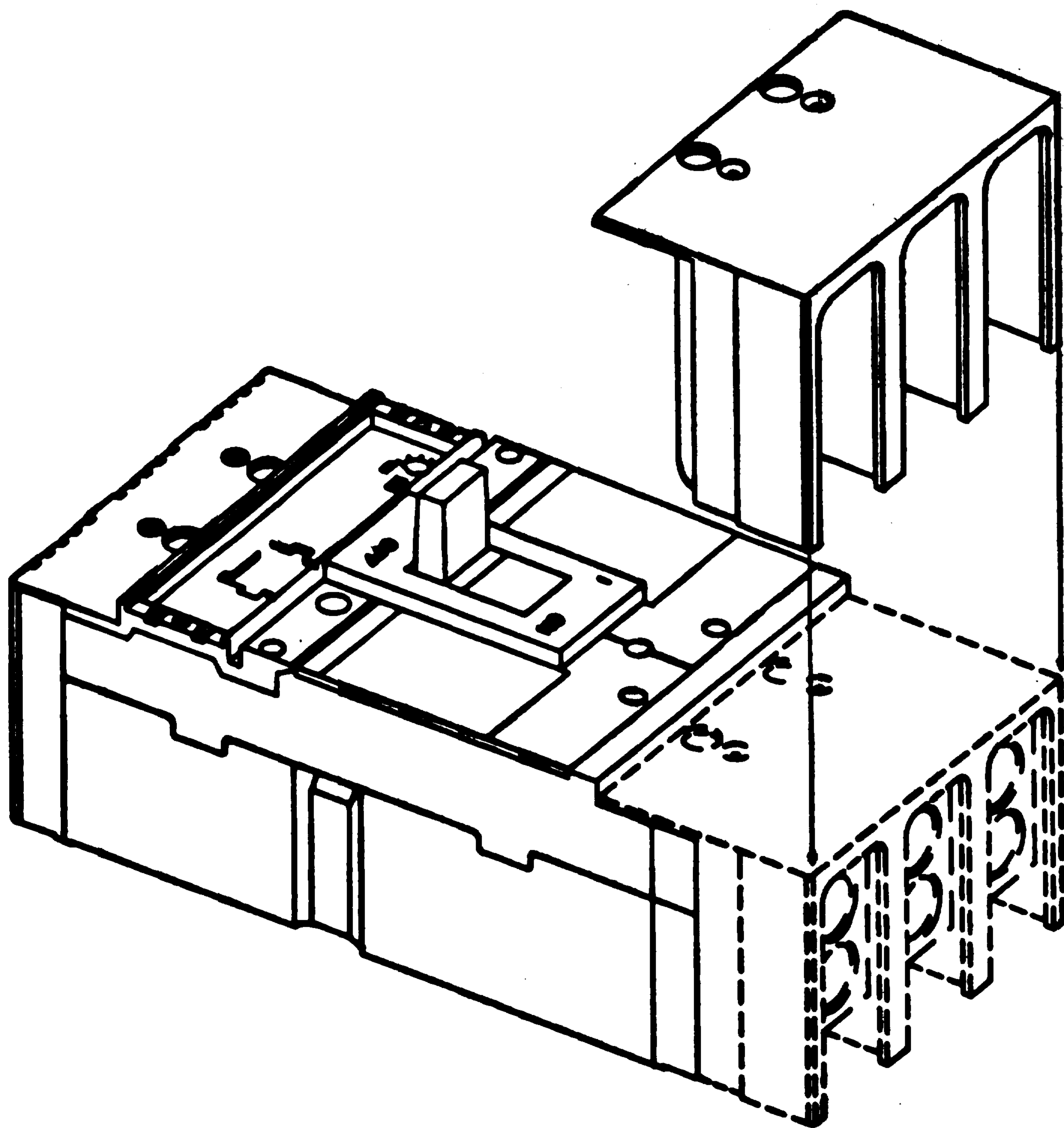

*Figure 2. Installation of the lug cover provided in the kit. Install as shown to maintain electrical clearances.*

These instructions do not cover all details or variations in equipment nor do they provide for every possible contingency that may be met in connection with installation, operation, or maintenance. Should further information be desired or should particular problems arise that are not covered sufficiently for the purchaser's purposes, the matter should be referred to your local GE ED&C Sales Office.



**GE Electrical Distribution & Control**