



Power Break[®] II

Insulated Case Circuit Breakers



imagination at work

Table of Contents

Power Break® II Circuit Breakers	3	Additional Accessories - Stationary Breakers	33
Basic Configuration	3	Lug Adapter Kits	34
Greater Convenience and Operator Safety	3	T-Studs	34
Quick, Error-Free Installation of Universal Accessories.....	3	Mechanical Interlocks	35
Four Choices of Advanced, Solid-State Trip Units.....	3	Lug Kits.....	35
Key Features.....	4	Additional Accessory - Drawout Breakers	35
Features and Characteristics	5	Secondary Disconnects	36
Basic Configurations	5	Shutters	36
Manual Operation	5	Racking Padlock	36
Electrical Operation	5	By-Pass Switch	36
Drawout Construction.....	6-7	Racking Tool	36
EntelliGuard® TU Trip Unit Systems	8	Mechanical Interlocks	36
Enhancements and Functions	8	Lifting Bar	36
Characteristics.....	9	Position Switch	36
Power+™ Trip Unit Systems	10	Catalog Numbers	37
Trip Target Module	10	Circuit Breakers	37
Operation of Power+™ Trip Units.....	11	Accessories	42
Long-Time Protective Functions.....	12	EntelliGuard TU Trip Units	43
Short-Time Functions.....	12	Rating Plugs	45
Normal Ground-Fault Protection	14	Power+™ Trip Units.....	46
Ratings Plugs	15	Rating Plugs	46
Current Sensors	15	MicroVersaTrip Plus™ and MicroVersaTrip PM™.....	47
MicroVersaTrip Plus™ and PM™ Trip Units	16	Rating Plugs	47
Enhancements	16	Application Data	48
Operation	17	Standards and Testing.....	48
Standard and Optional Protective Functions.....	17	Power Break® II - 100 % - Rated Circuit Breakers.....	52
Long-Time Protective Functions.....	18	Standard Rated Devices.....	52
Short-Time Functions.....	18	100% Rated Devices	52
High-Range Instantaneous	20	Factors Affecting the Current Ratings	52
Normal Ground-Fault Protection	20	Cable or Bus Size.....	52
Defeatable Ground-Fault Protection.....	31	Ambient Temperature	54
Programming Trip Units	24	Operating Frequency	54
Trip Targets - Overcurrent and Ground Fault	24	Factor "C" - Operating Frequency	54
Ratings Plugs	25	Altitude.....	55
Current Sensors	23	Load Class Rating Factor	55
Accessories	26	Interrupting Ratings	55
Stationary and Drawout Breakers.....	26	Basis of Interrupting Ratings.....	55
Test Kits	26	Miscellaneous Information and	
Electrical Operator	26	Control Power Information.....	58
Remote Close Solenoid.....	27	Humidity and Fungus	58
Shunt Trip	28	Wiring Diagram, Secondary Terminals.....	58
Shunt Trip with Lockout	29	Time Current Tripping Characteristics.....	58
Bell Alarm	29	Time Current Curves	59
Bell Alarm with Lockout	30	Physical Data	
Undervoltage Release Module.....	30	Outline Dimension Drawings.....	62
Time Delay Module for UVR.....	30	Weight and Space Requirements.....	118
Auxiliary Switch.....	31	Standards and References	119
Limited Access "Pushbutton Cover"	31	Guide Form Specifications	120
Mechanical Operations Counter	31	Other Related Publications	124
Padlock Device	33		
Key Interlock Provision	32		
Door Interlock	32		
Neutral Current Sensors.....	33		

Power Break® II Circuit Breakers



Basic Configuration

In 1965 GE pioneered the design of insulated case circuit breakers when it introduced the original Power Break circuit breaker. Now, GE introduces Power Break II insulated case circuit breakers, the vanguard of a new age in reliable, flexible and easy-to-use circuit protection.

Power Break II circuit breakers are UL Listed, CSA Certified and IEC Certified* for up to 200,000 amps, at 240 volts, rms symmetrical interrupting capacity without fuses or current limiters. These new insulated case circuit breakers can be applied on ac power systems through 600 volts. Featuring an all-new 2000A compact design – up to 40% smaller than before – Power Break II circuit breakers consist of three envelope sizes from 800 to 4000 amps.

Greater Convenience And Operations Safety

The controls and status indicators you need most are readily accessible. The flush-mounted handle, ON/OFF buttons, rating plug test receptacle, bell alarm reset buttons– with or without lockout – are easily reached; and all are double-insulated from live components. And, for added security, a standard padlock device lets you prevent accidental or unauthorized closing of the breaker.

Quick, Error-Free Installation of Universal Accessories

Drop-in bell alarm with manual reset lockout, shunt trip (with or without lockout) and undervoltage release install in seconds. No special tools. No breaker disassembly. Just slide them into place. The modules are universal across all frame sizes, and each is mechanically keyed to its compartment so you make the right connection, every time. These accessories are field installable and upgradeable.

Four Choices of Advanced, Solid-State Trip Units

New capabilities in the EntelliGuard® TU Trip Unit enhance the Power Break® II breaker with Waveform Recognition Instantaneous Algorithm, which eliminates costly downtime due to nuisance tripping, as well as Zone Selective Interlocking Instantaneous, which delivers simultaneous and independent ZSI of Short Time, Ground Fault and Instantaneous protection. The EntelliGuard® TU Trip Unit offers optimum circuit safety and arc flash protection with the Reduced Energy Let-Through function, providing a faster instantaneous trip that may be used in case faster and more sensitive protection is required temporarily.

Enhanced MicroVersaTrip™ Plus and MicroVersaTrip PM™ trip units give you many ways to monitor and control the Power Break II breaker with unprecedented ease. A simple keypad lets you program and display a variety of functions, including tripping characteristics, remote communications, status information and protective relaying, and allows integration with GE POWER LEADER™ Power Management Systems. The trip unit display also allows viewing of many standard metering parameters as well as pickup alarms, trip target indications and fault status information. For less demanding functionality, the Power+™ trip unit gives you a fourth choice in Power Break II breaker control. Tripping characteristics are easily adjusted by a set of simple-to use switches. The trip unit is upgradeable to ground fault by simply inserting a ground fault rating plug. An optional target module allows for target monitoring and also functions as a trip unit health indicator.

*See Performance chart page 56

Power Break® II Circuit Breakers

Key Features

- 1) Compact, lightweight design
- 2) 36-point pre-wired, dedicated secondary terminal block standard (see item 16)
- 3) Optional mechanical counter
- 4) Padlock device standard
- 5) Easy-to-reach ON/OFF buttons
- 6) Choice of EntelliGuard® TU, Power+™, MicroVersaTrip Plus™ or MicroVersaTrip PM™ trip units- field upgradeable, UL Listed, CSA Certified. IEC 947-2 Certified*
- 7) Sealable door provides added security
- 8) Drop-in shunt trip, undervoltage release and bell alarm (with and without manual lockout) modules
- 9) Flush-mounted pump handle

* See performance chart page 46.

Other

- Two-stage, stored energy mechanism provides charge-after-close capability
- Stationary and drawout versions (stationary shown)
- Manually and electrically operated versions in same envelope
- Modular, field-installable motor operator and remote-close solenoid with independent voltages available
- All frames upgradeable to POWER LEADER™ Power Management Systems
- Configurable accessories activated through integrated electronics provide new status information and allow new flexibility in bell alarm and lockout control
- Modular auxiliary switches mounted beneath trip unit with up to 12 NO/NC sets of contacts (Internal)
(Up to 36 terminals pre-wired to item 2, left side of breaker)

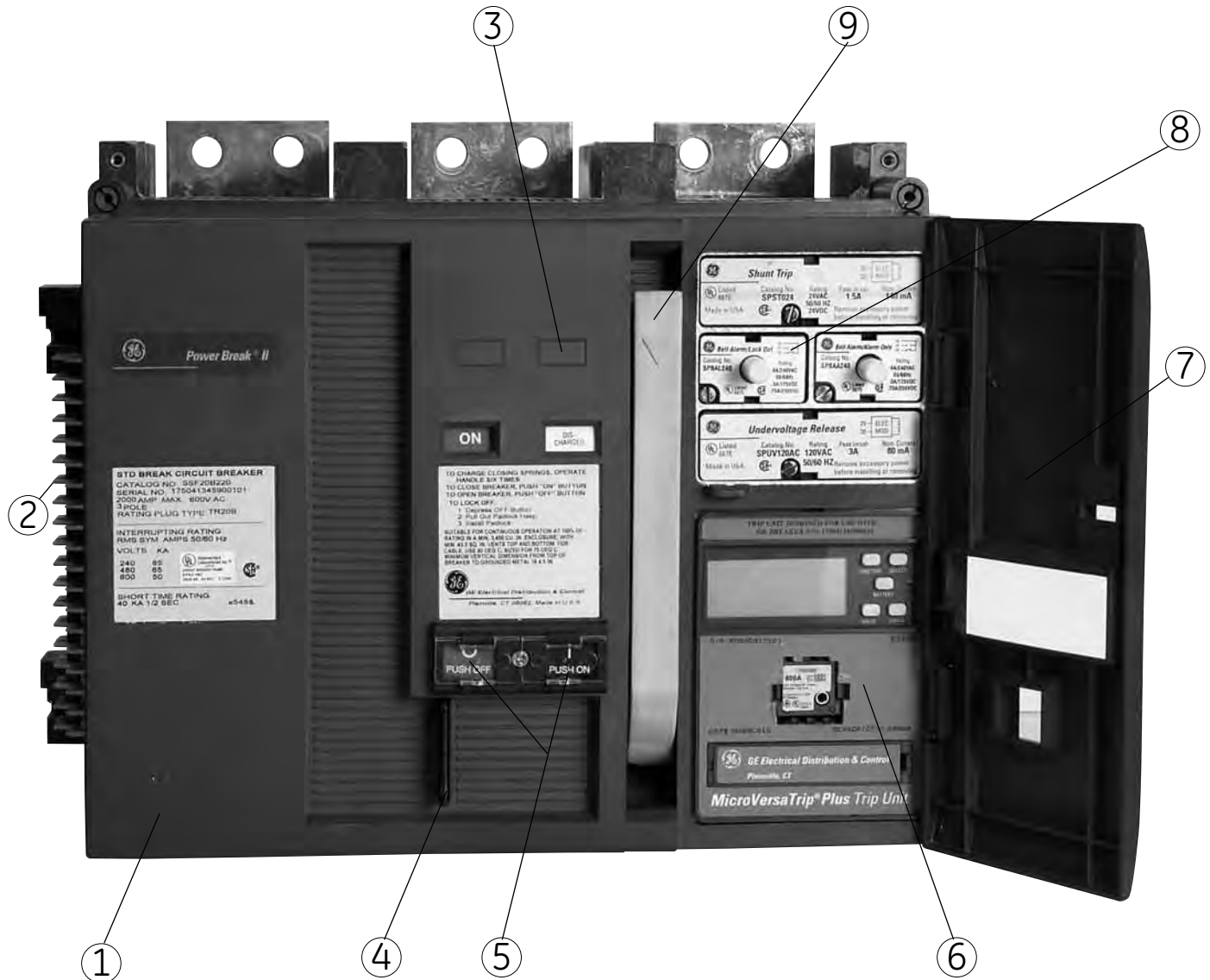

Features and Characteristics

Basic Configurations

All Power Break® II circuit breakers are available in two levels of interrupting capacity – “standard break” and “Hi-Break®” breakers. Each interrupting level is available in both stationary and drawout construction, with a full complement of control and signaling accessories.

Standard break breakers are designed to meet the majority of application requirements, calling for moderate levels of available short-circuit current.

Hi-Break breakers, on the other hand, are specially designed to withstand the stresses, and safely interrupt high levels of short circuit current found in some applications (from 65 to 200 kA rms symmetrical amps – depending on voltage).

Manual Operation

The circuit breaker closing spring is energized by size operations of the retractable pump handle. Each handle movement is a stage in the pre-charging of a spring-loaded, quick-make, quick-break mechanism. To close the breaker contacts, depress the “PUSH ON” button. With the breaker in the “ON” position, it is now possible to recharge the main closing springs by repeating the spring charging procedure.

The circuit breaker opening springs are automatically charged when the breaker is closed. To open the breaker and de-energize downstream circuits, manually depress the “PUSH OFF” button.

Electrical Operation

The electrical operation fits under the cover of the manually operated breaker. This assembly may be added to any Power Break II breaker – in the factory or in the field – to provide the electrical charge feature. All breaker controls inputs and outputs are pre-wired to dedicated secondary terminals for



Operation of circuit breaker pump handle

easy field installation. To complete the remote-operation feature, a remote-close solenoid and either a shunt trip (with or without lockout) or undervoltage release accessory is also required. The electrical operator can be wired to automatically re-charge the breaker after CLOSE or upon command. Should motor control power be lost during the charging cycle (3 seconds duration), spring charging may be completed manually by using the pump handle. No special tools are required. Any electrically operated breaker may be operated manually.

For details of electrical control power requirements and wiring diagrams, see pages 27-28..

Breaker Closing Speed

Three-cycle maximum closing speed, at nominal voltage, is standard for all frame sizes. This speed exceeds the requirements for generator synchronizing.

Table 7.1
Sequence Of Operation

ON/OFF Indicator	Main Breaker Contacts	Charging Spring Indicator	Condition of Charging Spring	Next Permissible Operating Function
OFF	Open	Discharged	Discharged	Closing springs may be charged
OFF	Open	Charged	Fully Charged	Contacts may be closed
ON	Closed	Discharged	Discharged	Contacts may be opened, or closing springs may be charged
ON	Closed	Charged	Fully Charged	Contacts may be opened
OFF	Open	Charged	Fully Charged	Closing spring may be discharged without closing contacts by depressing OFF button while pushing ON button

Features and Characteristics

Drawout Construction

Type SSD (standard break) and SHD (Hi-Break®) Power Break II drawout breakers are used in type SPSDOS and SPHDOS substructures, providing the convenience and safety inherent in drawout breaker construction. Drawout construction permits activation of a new feeder, rapid circuit breaker replacement, or inspection and maintenance of a breaker without the inconvenience of de-energizing an entire switchboard.

Features (see photos, following page)

- 1) **Primary disconnects:** primary power is fed through multiple finger primary disconnect terminals when connected to the primary stabs in the substructure.
- 2) **Secondary disconnects:** control signals are provided through the 72 (36 maximum each side) secondary disconnect terminals in the test and connected positions only.
- 3) **Wheels:** the breaker has rollers which allow the unit to ride on the substructure's retractable rails for easy removal and installation.
- 4) **Wrench interlock:** an interlock prevents engagement of the racking wrench when the breaker contacts are closed. This prevents disconnecting a closed breaker.
- 5) **Drawout position indicator and switch:** a drawout position indicator displays whether the breaker is in the connected, test or disconnected position.
- 6) **Padlocking device:** a padlocking provision accessory is available to prevent access to the racking shaft, preventing movement of the breaker between the disconnected, test and connected positions. (Not shown.)
- 7) **Lifting bar:** a lifting bar is available as an accessory, and should be used to assist in safe handling of the drawout breaker.
- 8) **Manual motor cut-off switch:** provided as standard – prevents motor charge when racking breaker in from disconnect to test position.

Other

- **Drawout interlock:** this interlock will trip a closed breaker before the primary disconnects are engaged or disengaged in the event that the wrench interlock is intentionally defeated.
- **Drawout mechanism:** a racking shaft powers a centrally mounted power screw, through a chain drive, into a fixed nut in the substructure. A special speed wrench is available with an integral ½" square drive socket. The wrench is used for racking the breaker in and out of the substructure.
- **Rejection feature:** a built-in rejection feature prevents insertion of a breaker into an incorrect substructure. This prevents either: insertion of a standard break breaker into a Hi-Break breaker substructure, or insertion of a higher ampere rated breaker into a lower ampere rated substructure, or both.
- **Shutters:** shutters are available as an accessory to protect personnel from inadvertently touching the primary stabs of an energized switchboard when the drawout breaker unit is removed.
- **By-pass switch:** a by-pass switch accessory has NO and NC single-pole double-throw (SPDT) contacts, which change state when the breaker is racked from the connected to the test position. The switch is available in 2, 4, and 6-contact modules.
- **Substructure:** the substructure is a self-contained framework serving as a stationary receptacle for Power Break II drawout breaker types SPSDOS and SPHDOS. It permits easy activation of a new circuit in a spare compartment (hole filler), rapid breaker replacement and simplifies inspection and maintenance. The substructure is designed for convenient mounting, with holes provided for bolting on a shelf of supports. Holes are also provided in the primary stabs for bolting to busbars or terminal lugs. The substructure also has retractable rails which aid in the installation of the drawout breaker.

Features and Characteristics

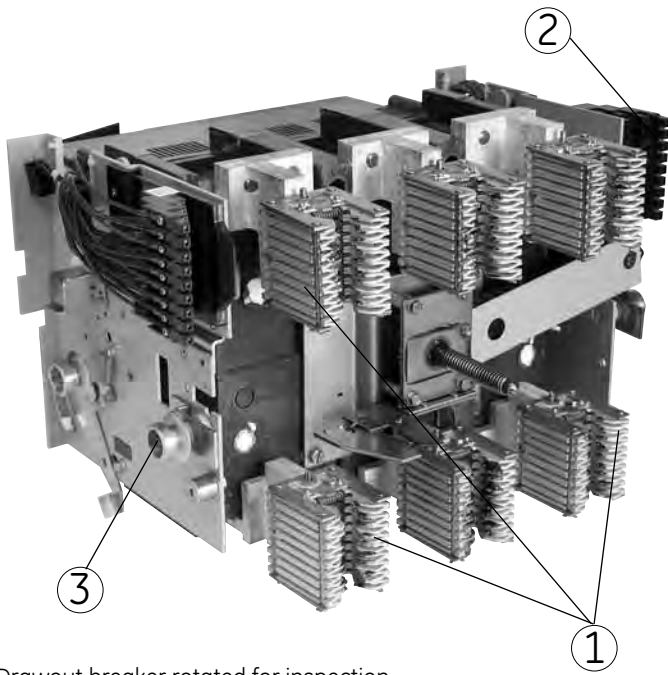

Drawout breaker rotated for inspection

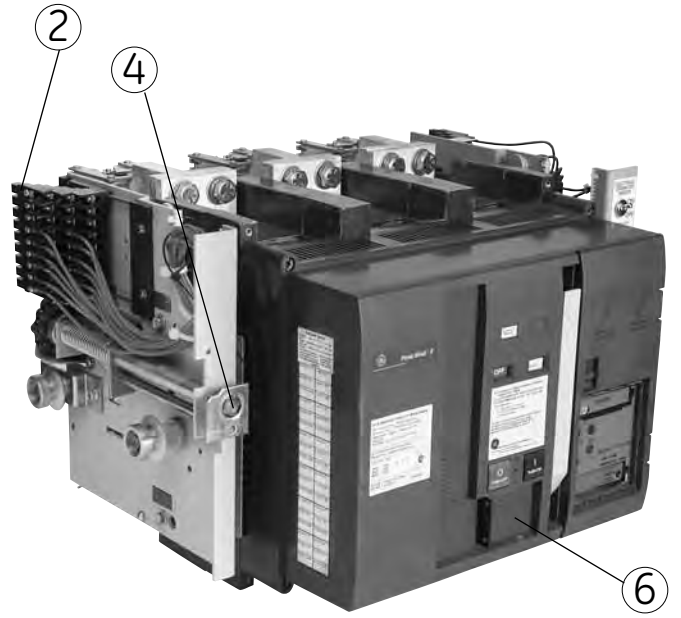

2000-amp drawout breaker

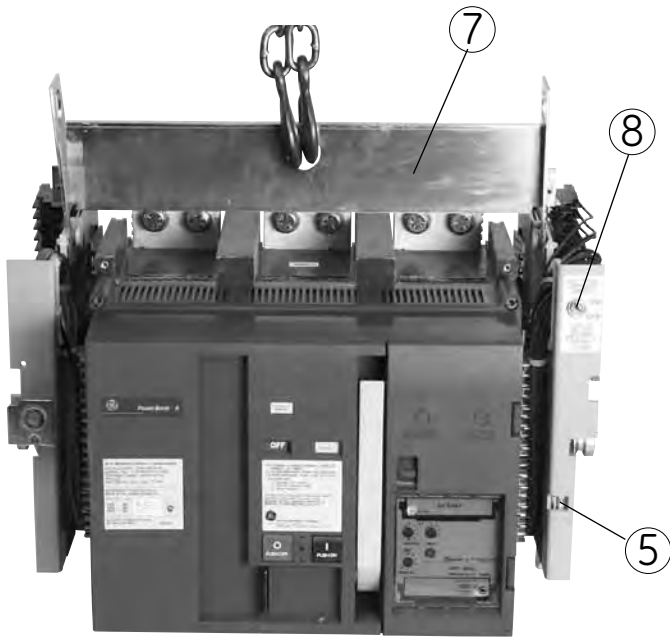

2000-amp drawout breaker lifting bar and TDQLR

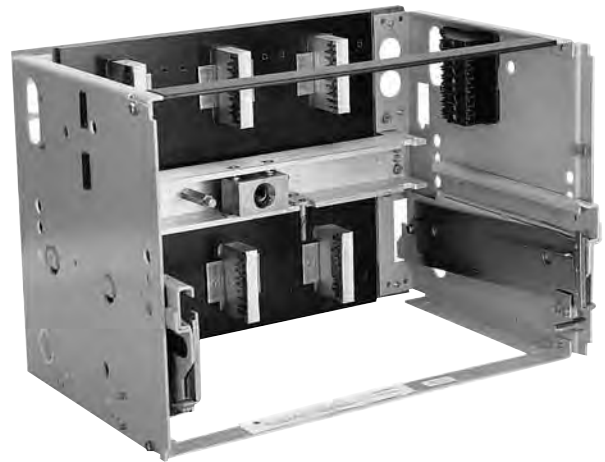

1600-ampere substructure for standard break breaker

Features and Characteristics

EntelliGuard® TU Trip Unit



New capabilities in the EntelliGuard® TU Trip Unit provide optimum system reliability and selectivity without sacrificing circuit protection. It is a superior addition that will enhance the Power Break® II with new functions in order to obtain reliability and arc flash protection, in one package, at the same time, all the time.

Standard Features

- Flexible time current settings
- 22 I²T Long Time Curves, Long Time Delay
- 22 Fused Long Time curves (I4T)
- Short Time, Short Time Delay, 3 Short Time I²T slopes
- Waveform Recognition Instantaneous
- Ammeter
- Large backlit LCD screen*
- Date and time*
- Breaker status indication
- Universal rating plugs
- Status and event log (10 Events)
- LED health status indicator*
- Set-up software
- I/O – 1 input and 1 output*
- Thermal memory, battery back-up
- Common interface across all versions

Options

- Internal/external ground fault trip or alarm with 4 curves to select from (I2T, I4T, SGF, Definite Time Slope)*
- Switchable ground fault trip / alarm (Not UL Listed)
- Modbus open RTU communications*
- Waveform capture – enables harmonic analysis
- Full-function metering*
- Protective relaying*
- Zone Selective Interlock – GF, S, I*
- RELT – Reduce Energy Let Through*
- RELT and ground fault alarm harness kits
- Test Set GTUTK20

Arc flash protection and selectivity at the same time

The EntelliGuard TU Trip Unit offers optimum circuit protection and system reliability simultaneously, with little or no compromise to either of these critical functions. With its Reduced Energy Let-Through Setting (RELT), the system protects at HRC1 or 2 for available fault currents as high as 100kA.

Algorithms enabling arc flash protection and selectivity

- RELT – Reduced Energy Let Through
- Zone Selective Interlocking – Instantaneous (ZSI-I)
- Waveform Recognition Instantaneous – coordinates with current limiting devices and reduces nuisance trips
- Flexible time current curves – create the shape you need

Reliability – Health Status

- Non-volatile memory with continuous self-testing microprocessor
- Health Status LED indicates normal operation, errors, pickup, trip
- External power not required with long-life lithium battery
- Positive setpoint recognition, values flash until saved

Plug and Play

- Same form, fit, function as the popular MicroVersaTrip trip unit, simplifying upgrade to an existing converted breaker*

Optional full-function metering

- Current (Amps, kAmps)
- Voltage (Ph-Ph, Ph-N)
- Energy (kWh, MWh, GWh)
- Real power (kW, MW)
- Total power (kVA, MVA)
- Frequency (Hz)
- Demand (avg. kW, MW) and peak demand

Optional protective relaying functions

- Undervoltage
- Overvoltage
- Voltage unbalance
- Current unbalance
- Power reversal
- Power direction setup

*Note: Some options require 24VDC additional hardware to enable Metering, Relaying, RELT, ZSI, Modbus to be added to the breaker, equipment cubicle and equipment sections.

Features and Characteristics

Table 9.1
EntelliGuard® TU Trip Unit Characteristics

Envelope Size	Frame Max. Amp Rating	Sensor Rating (Amps) (S)	Long-Time			Short-time	
			Current Setting © (Pick-up) Multiple of Rating Plug Amps (X)	Delay ^① Seconds		Pick-up (Multiple of Current Setting) (C)	Delay Seconds
				Thermal Type (C Bands)	Fuse Type (F Bands)		
800	800	200, 400, 800	0.5 thru 1.0 in	0.20	0.025	1.5 thru 9.0	I ² T in ^① Minimum – .046 Intermediate – .186 Maximum – .418
1600	1600	800, 1000, 1600		0.60	0.025		
				1.21	0.025		
				1.61	0.032		
				2.41	0.044		
				3.21	0.059		
2000	2000	2000		4.02	0.078		
				4.82	0.100		
				5.62	0.130		
				6.43	0.170		
3000	2500	1000, 2000, 2500		7.23	0.220		I ² T out ^② .025, .033, .042, .058, .092, .117, .158, .183, .217, .350, .417
				8.04	0.270		
				9.64	0.350		
				11.20	0.440		
				12.90	0.550		
4000	4000	4000		14.50	0.690		
				16.10	0.870		
				17.70	1.100		
				19.30			

Trip Unit Characteristics (continued)

Envelope Size	Adjustable Instantaneous Pick-Up without ST (Multiple of Rating Plug Amps) (X)	Adjustable Instantaneous Pick-Up with ST (Multiple of Rating Plug Amps) (X)	RELT without ST	RELT with ST	Ground Fault			
					Pick-Up (Multiple of Sensor Amp Rating)	Delay with I ² T (Seconds)	Slope Bands	Fixed Delay
800	2.0 thru 10.0	2.0 thru 15.0	1.5 thru 10.0	1.5 thru 10.0	0.20 thru 0.60	.44 at 200% of pick-up at lower level of band	I ² T – .385 I ⁴ T – .385 SGF – .553	0.058
1600	2.0 thru 10.0	2.0 thru 15.0	1.5 thru 10.0	1.5 thru 15.0	0.20 thru 0.60			0.092
								0.117
								0.158
2000	2.0 thru 10.0	2.0 thru 15.0	1.5 thru 10.0	1.5 thru 13.0	0.20 thru 0.60			0.183
3000	2.0 thru 10.0	2.0 thru 13.0	1.5 thru 10.0	1.5 thru 13.0	0.20 thru 0.37	0.217		
						0.350		
4000	2.0 thru 9.0	2.0 thru 9.0	1.5 thru 9.0	1.5 thru 9.0	0.20 thru 0.30	0.417		
						0.517		
						0.617		
						0.717		
							0.817	
							0.917	

- ① Time delay shown at 600% of current setting at lower limit of band.
- ② Time delay shown at lower limit of each band. All pick-up tolerances are ±10%.
- ③ Time delay shown at lower limit of each band. Ground fault pick-up not to exceed 1200 amps.
- ④ Time delay shown at 200% of pick-up at lower limit of band.

X= Rating plug amps
S= Sensor amp rating
C= Long-time current setting (pick-up)

Power+™ Trip Units

Power+™ Trip Unit Systems*

The Power+ trip unit system for Power Break®II insulated case breakers consist of the trip unit, the trip actuator, current sensors and rating plugs. The term “trip unit system” applies to the combination of these four components which form the solid-state circuit breaker tripping system.

Power+ trip units provide a complete range of standard and optional overcurrent and ground-fault protective functions.



Components of Power+ trip unit system

True RMS Sensing

The Power+ trip unit continues to use GE's proven technique of measuring true rms currents of both sinusoidal and harmonically distorted waveforms. The frequent sampling (48 times per cycle per phase) allows precise calculations of true rms current. The sampling rate allows waveform measurements up to the 11th harmonic. GE's true rms sensing avoids potential underprotection or overprotection problems associated with peak-sensing tripping systems.

Accessory Integration

Four accessories are integrated through the Power+ trip unit. Drop-in shunt trip (with or without lockout), bell alarms (with or without lockout) and the undervoltage release modules fit into keyed pockets. They operate through the trip units, and not through any external mechanisms. All accessory wiring is pre-wired to secondary terminals, and no user wiring is necessary. When activated, the shunt trip (with or without lockout) and undervoltage release modules send a signal to the trip unit to energize the trip actuator and open the breaker.

* For availability on Power+ Trip units, contact your GE sales engineer.

Trip Target Module (Optional)



Power+ trip target module (Target 02)

- **View Button:** Press the VIEW button to check the trip unit status.
- **Reset Button:** Press the RESET button to clear any target that is set.
- **Battery Check:** Target modules use two standard, 3V, 16mm x 1.6 mm, lithium batteries for viewing target information. Battery life depends upon use, but may be estimated at one year. When the batteries are energized, depressing the VIEW button will illuminate either a set target LED, i.e., LT or the BAT LED. Once target indicators are cleared, battery status is indicated by the BAT LED. Replacement batteries include Panasonic CR1616, Eveready E-CR1616BP, or Duracell DL1616B, which may be purchased commercially.
- **Long-time pickup:** The long-time pickup indicators moves through two transitions. As the current in any phase reaches 95% of its setpoint, the LTPU LED begins to flash. As current increases, flashing frequency increases, until 100% of the pickup point is reached. At that moment, the LTPU LED stays on continuously until the long-time delay times out. Once the breaker has tripped on long-time, the OVL target will be stored in memory. To view the trip, press the VIEW button. To clear the target, press the RESET button.
- **Short-time and instantaneous trips:** Short-time and instantaneous trips share the same trip target. The LTPU LED is not illuminated, since the time intervals between pickup and tripping are too short for either function. Once the breaker has tripped on short-time or instantaneous, the short target will be stored in memory. To view the trip, press the VIEW button. To clear the target, press the RESET button.
- **Ground fault trip (Target02 only):** The trip target for a ground fault is the GF LED. To view the trip, press the VIEW button. To clear the target, press the RESET button.
- **Health monitor:** Trip unit health status “okay” is illustrated by slow blinking of the LTPU LED. It may be seen by depressing and holding the VIEW button. Sufficient power must be supplied to the trip unit via external test kit, power pack, or current transformers for the health monitor to be operational.

Power+™ Trip Units

Operation Of Power+™ Trip Units

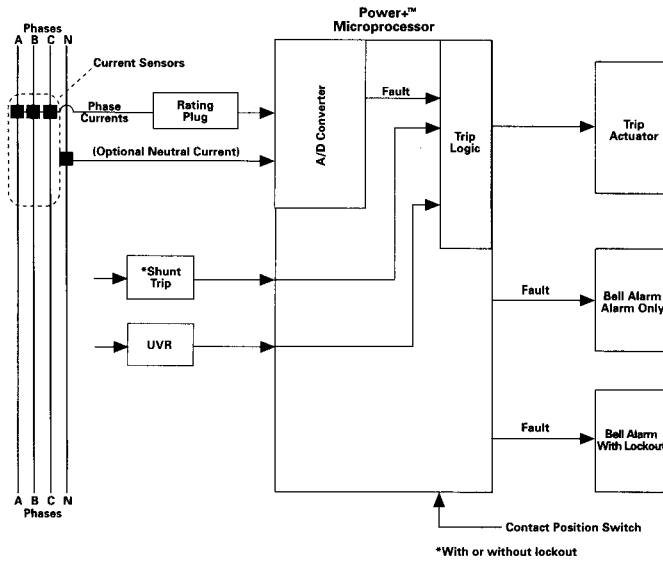

Block diagram of Power+ trip unit

Power+ trip units have a variety of standard and optional functions. The block diagram shows a fully configured Power+ trip unit with ground-fault protection. The current sensors are special current transformers that provide the trip unit with its operating power. Interchangeable rating plugs act as scalars for the outputs of the current sensors, as well as establish the current rating of individual breakers. When a four-wire system is used and ground-fault protection is called for, an external neutral sensor is necessary.

Analog current signals are converted to digital values, and are measured and compared with established trip settings in the microprocessor's memory. Any overcurrent or ground fault condition that exceeds pre-set conditions produce a trip signal from the microprocessor to the trip actuator. The trip actuator is a low-energy, positive-action tripping device. The low-level trip signal counteracts the strength of the actuator's permanent magnet, and allows a spring to unseat the magnet and trip the breaker.

Both the shunt trip and undervoltage release (UVR) accessories also produce trip signals to the trip actuator when energized. The two bell alarms operate only as a result of an overcurrent trip condition.

Standard And Optional Protective Functions

Standard and optional protective functions for Power+ trip units are shown below. The breaker settings are programmed in multiples of "X" (rating plug amp values), "S" (current sensor amp rating values), and "C" (the long-time setting in amps—multiply long-time setting by rating plug amp rating).

Standard

- Adjustable Long-Time (L) Pickup, 0.5 – 1.0X, with four delay bands.
- Adjustable Instantaneous (I) Pickup, 1.5 – 15X.*

Options

- Overload, Short Circuit, and Short-Time local trip indicators with overload pickup warning and health monitors.
- Adjustable Short-Time (S) Pickup, 1.5 -9.0C, and delay (3 bands) with I²t ON/OFF selection.
- Adjustable Ground Fault (G) Pickup, 0.2 - 0.6S, and delay* (3 bands) with I²t ON/OFF selection and trip indicator.
- Upgradeable Ground Fault function with use of appropriate ground rating plug.

* Limited by breaker frame size above 2000A.

Power+™ Trip Units

Long-Time Protective Functions

Long-Time Function / Current Setting (Standard)

The adjustable long-time setting is based on multiples of “X”, the rating plug amp rating. There are 7 possible settings from 50% to 100% of rating plug amps. This setting establishes the current setting of the breaker, which is the current the breaker will carry continuously without tripping. Multiplying the long-time setting by the rating plug value establishes the value of “C”. For example, a breaker with a 95% long-time setting and 500-amp rating plug (X), would have a 475-amp current setting, or value of C.

(Long-time current setting (C) = (0.50 to 1.00) × rating plug (X))

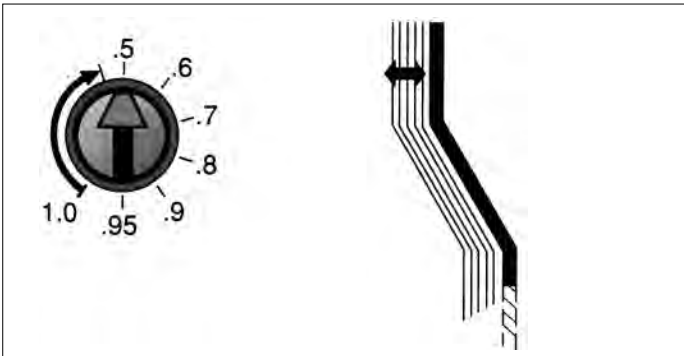

Long-time function or current setting

Long-Time Delay (Standard)

Long-time delay varies the time it will take the breaker to trip under sustained overload conditions. It permits the breaker to ride through momentary predictable overloads (e.g., motor starting) without tripping. There are 4 time bands that provide nominal delays from 3 to 25 seconds at 600% of the breaker’s current setting, or value of C.

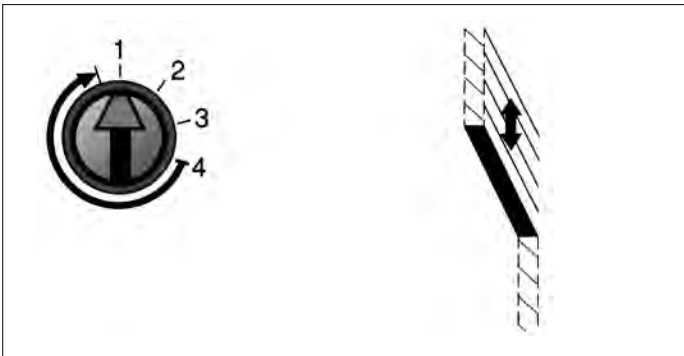

Long-time delay

Instantaneous Function (with Power+ Trip Units)

All Power Break® II breakers have the standard instantaneous trip function. The instantaneous trip point establishes the value of current that will trip the breaker without intentional time delay. Instantaneous trip times are 50 milliseconds, or less. Instantaneous trips are the result of severe overcurrent or short-circuit conditions, and damage to the power system is minimized by immediate tripping. Standard settings are adjustable in multiples of the rating plug amp value (X). See Table 13.1 for allowable values. The trip unit will limit the instantaneous trip level so that the breaker withstand rating is not exceeded. Maximum setting is dependent on breaker frame size.

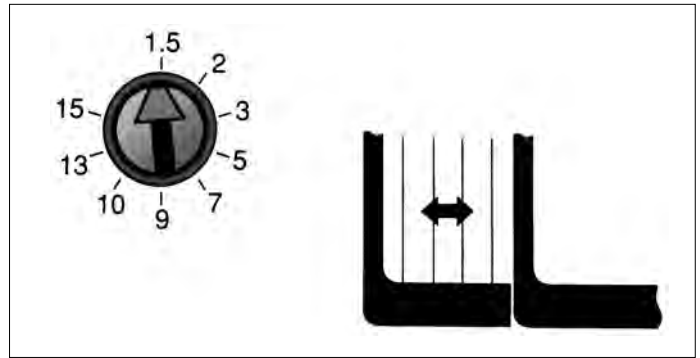

Standard instantaneous function

Short-Time Functions (Optional)

Short-Time Pickup

The short-time pickup function controls the level of high current the breaker will withstand for short periods of time to allow downstream devices to clear faults without tripping the breaker. Settings are adjustable in increments of the breaker current setting (C). See Table 13.1 for allowable values. If the instantaneous setting is set for lower values of current than the short-time function, the instantaneous function prevails.

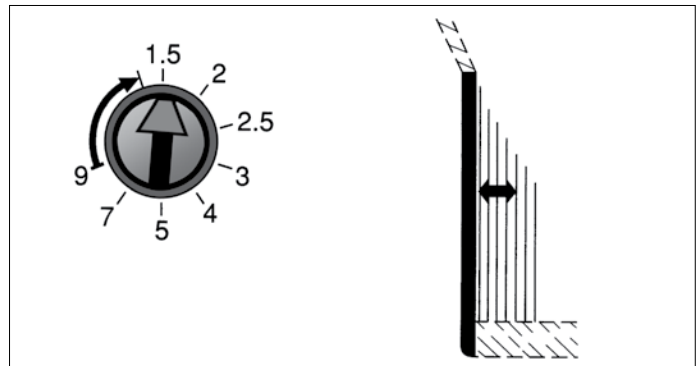

Short-time pickup function

Power+™ Trip Units

Table 13.1
Power+™ Trip Unit Characteristics

Envelope Size	Frame Max. Amp Rating	Sensor Rating (Amps) (S)	Long-Time		Short-time	
			Current Setting © (Pick-up) Multiple of Rating Plug Amps (X)	Delay ① Seconds (4 Bands)	Pick-up (Multiple of Current Setting) (C)	Delay Seconds (3 Bands)
2000	800	200, 400, 800	0.5, 0.6, 0.7, 0.8, 0.9, 0.95, and 1.0	2.4, 4.9, 9.8, 20	.5, 2.0, 2.5, 3.0, 4.0, 5.0, 7.0 and 9.0	I ² T in ^① .10, .21, .35
	1600	800, 1000, 1600		2.4, 4.9, 9.8, 20		
	2000	2000		2.4, 4.9, 9.8, 20		
3000	2500, 3000	1000, 2000, 2500, 3000		2.4, 4.9, 9.8, 20		I ² T out ^② .10, .21, .35
4000	4000	4000		2.4, 4.9, 9.8, 20		

Trip Unit Characteristics (continued)

Envelope Size	Adjustable Instantaneous Pick-Up without ST (Multiple of Rating Plug Amps) (X)	Adjustable Instantaneous Pick-Up with ST (Multiple of Rating Plug Amps) (X)	Ground Fault	
			Pick-Up (Multiple of Sensor Amp Rating)	Delay ③ Seconds (3 Bands)
2000	1.5 thru 10.0	1.5 thru 15.0	0.20 thru 0.60	I ² T in ^④ .10, .21, .35
	1.5 thru 10.0	1.5 thru 15.0	0.20 thru 0.60	
	1.5 thru 10.0	1.5 thru 15.0	0.20 thru 0.60	
3000	1.5 thru 10.0	1.5 thru 13.0	0.20 thru 0.37	I ² T out ^② .10, .21, .35
4000	1.5 thru 9.0	1.5 thru 9.0	0.20 thru 0.30	

- ① Time delay shown at 600% of current setting at lower limit of band.
- ② Time delay shown at lower limit of each band. All pick-up tolerances are ±10%.
- ③ Time delay shown at lower limit of each band. Ground fault pick-up not to exceed 1200 amps.
- ④ Time delay shown at 200% of pick-up at lower limit of band.

X= Rating plug amps
S= Sensor amp rating
C= Long-time current setting (pick-up)

Power+™ Trip Units

Short-Time Delay

Short-time delay is always provided when short-time pickup is ordered. Short-time delay provides additional refinement in providing coordination between upstream and downstream protective devices. There are three time delay bands that provide delays from 100 ms to 350 ms of 1 (MIN), 2 (INT), 3 (MAX).

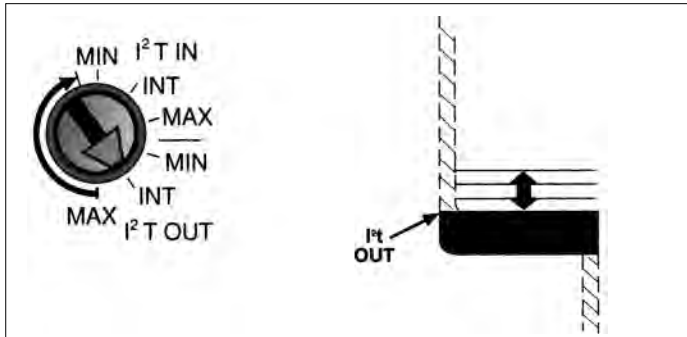

Short-time delay with I^2t OUT

Selectable Short-time I^2t Function

Selectable short-time I^2t is always provided with the short-time option. The I^2t helps the solid-state trip unit coordinate with downstream thermal magnetic devices or fuses. This function impacts the shape of short-time and short-time delay time current curves, and may be programmed either IN or OUT.

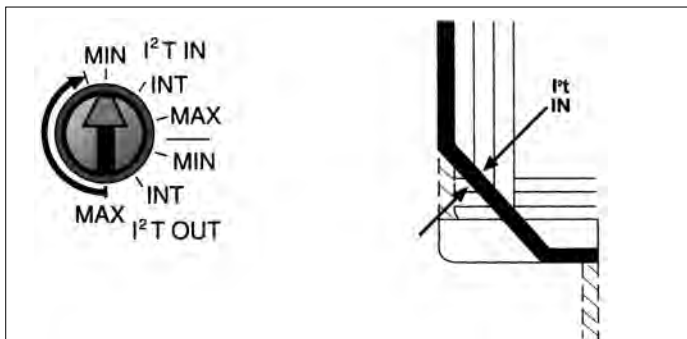

Short-time delay with I^2t IN

Normal Ground-Fault Protection (Optional)

Ground-Fault Protection

The ground-fault function in the Power+™ trip unit is field upgradeable. It is enabled and adjusted through the rating plug. To upgrade to the ground-fault option, simply remove the non-ground fault rating plug that does not have the ground-fault option and install a ground-fault rating plug. A ground-fault is an unintentional current flow from a circuit through a conductive path to ground. Ground faults usually have intermittent or very low values of current flow, as depicted in Graph A, and are not detected by long-time overload protection.

Some ground-fault trip systems may not detect this type of fault because the intermittent nature of the fault never exceeds the trip threshold as illustrated in Graph B.

The Power+ trip unit detects and integrates (adds a series of arcing and intermittent current pulses) the low-level current of a ground fault. This integration function provides a memory response for ground faults to achieve preferred ground-fault protection as shown in Graph C.

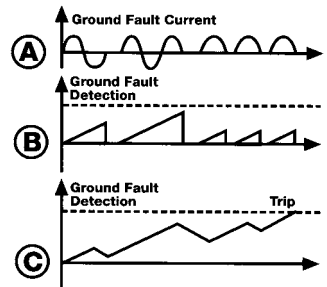

Ground-fault memory circuit

The NEC requires that the maximum ground-fault setting not exceed 1200 amps. Ground-fault protection includes pickup setting, ground-fault delay settings and selectable I^2t function.

Ground-fault pick-up settings are based on multiples of S , the current sensor rating. The lowest setting is 20% of S , and the highest setting is based on current sensor amp ratings, such that the maximum setting does not exceed 1200 amps. There are three ground-fault delay bands of 1 (MIN), 2 (INT), 3 (MAX) ranging from 100 ms to 350 ms. The I^2t function adds an I^2t slope to the square corner of the ground-fault time current curve transition, from pickup to the constant delay bands, to improve coordination with downstream devices.

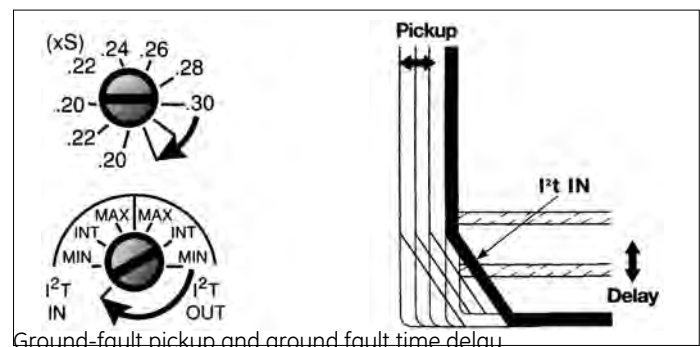

Ground-fault-pickup and ground fault time delay

Power+™ Trip Units

Rating Plugs



Power+™ trip unit rating plug

A new interchangeable rating plug is used in the Power+™ trip unit across the entire Power Break® II breaker product line. Rating plugs are the key devices that establish the current rating of the breaker. They provide an essential scaling function for the unit's microprocessor, and ensure maximum accuracy. They also provide an external jack for connection to an external battery pack, or TVRMS2 test kit.

Rating plugs have rejection features that allow them to be inserted only with breakers containing the correct current sensors. Rating plugs for the Power+ trip unit cannot be used with Spectra RMS™ molded case circuit breakers or with MicroVersaTrip Plus™ and MicroVersaTrip PM™ trip units. See Table 15.1 below.

Current Sensors

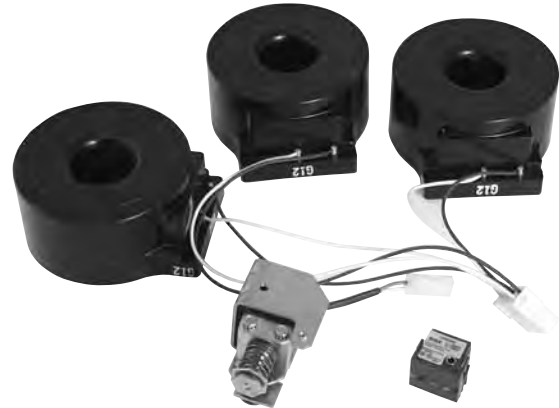

Typical toroidally wound sensor

Toroidally wound current sensors are furnished for all major protective functions, and for use with Power+™ and MicroVersaTrip PM trip units. Current sensors are factory installed and are not changeable in the field. There are 11 current ratings for the Power Break II breaker line through 4000 amps. See Table 15.1 for current ratings. Rating plugs must be coordinated with the current sensor rating (S) listed on the face of the rating plug.

Table 15.1
Rating Plug And Current Sensor Rating

Envelope Size	Frame Max Rating (Amps)	Sensor Rating (Amps) (S)	Sensor Rating Plug Amps (X)
2000	800	200	100, 150, 200
		400	200, 225, 250, 300, 400
	800, 1600	800	400, 450, 500, 600, 700, 800
		1600	600, 800, 1000
	2000	2000	800, 1000, 1100, 1200, 1600
3000	2500	1000	1000, 1200, 1500, 1600, 2000
		2000	600, 800, 1000
		2500	1000, 1200, 1500, 1600, 2000
	3000	3000	1600, 2000, 2500
4000	4000	4000	2000, 2500, 3000
4000	4000	4000	1600, 2000, 2500, 3000, 3600, 4000

S= Sensor amp rating X= Rating plug amp

MicroVersaTrip Plus™ and PM™ Trip Units

The Enhanced MicroVersaTrip Plus™ And MicroVersaTrip PM™ Trip Unit Systems

The Enhanced MicroVersaTrip Plus and MicroVersaTrip PM trip unit systems for Power Break® II insulated case breakers consist of the trip unit, the trip actuator, current sensors and rating plugs. The term “trip unit system” applies to the combination of these four components which form the solid-state circuit breaker tripping system.

MicroVersaTrip Plus trip units provide a complete range of standard and optional overcurrent and ground-fault protective functions. MicroVersaTrip PM units add advanced metering, communications and protective relaying functions. MicroVersaTrip PM trip units are designed to function as part of the GE POWER LEADER™ Power Management System.



Components of MicroVersaTrip Plus trip unit system

True RMS Sensing

Enhanced MicroVersaTrip Plus and MicroVersaTrip PM trip units continue to use GE's proven technique of measuring true rms currents (and voltages for MicroVersaTrip PM trip units) of both sinusoidal and harmonically distorted waveforms. The frequent sampling (64 times per cycles per phase) allows precise calculations of true rms current. The sampling rate allows waveform measurement up to the 31st harmonic to achieve accuracies of 99%. GE's true rms sensing avoids potential underprotection or overprotection problems associated with peak-sensing tripping systems.

Enhancements to MicroVersaTrip Plus and MicroVersaTrip PM Trip Units

Enhancements include several new functions that simplify programming and make fault displays easier to read and interpret.

Batteries

Replaceable, long-life lithium batteries provide programming and display power to the trip unit's LCD on command. The trip unit can be removed from the breaker, and all setpoints can be defined at a technician's desk. The integral conservation feature extends battery life. The batteries are automatically shut off when no programming operation or display request is called for within 30 seconds after the last key is pressed. The batteries also enable the user to read fault displays on an open breaker.

The battery is intended to power the Trip Unit when it is otherwise unpowered. At low currents the Trip Unit Display is not active. Pressing the BATTERY key under these conditions will not activate the display. The MicroVersaTrip Plus trip unit display is on as long as a small amount of current (minimum 20% of current sensor rating) is flowing in the breaker current sensors. The displays of installed MicroVersaTrip PM units are visible at all times due to an external +24Vdc power supply accessory.

The batteries are not required to maintain programmed settings, or store trip information. They simply provide a local power source to energize the programmer when no other source of power is available. All setpoints, time delays and other programming functions are stored in non-volatile memory within the trip unit's microprocessor.

Batteries have a two-year life under normal use. They are user-replaceable.

LCD

The LCD – liquid crystal display – has increased contrast to improve legibility in poor lighting conditions. New international displays symbols are used for various programming functions (e.g., “I>>” for short circuit and “I>” for overload).

Trip Operations Counter

The enhanced MicroVersaTrip Plus and MicroVersaTrip PM Trip unit also store and display the total number of trips due to long time overloads, short time and instantaneous short circuits, and ground faults. Each display stores up to 256 operations per trip category before resetting to zero. Each counter can be individually reset through the keypad.

Accessory Integration

Four accessories are integrated through the MicroVersaTrip Plus and MicroVersaTrip PM trip units. Drop-in shunt trip (with or without lockout), bell alarms (with or without lockout) and the undervoltage release modules fit into keyed pockets. They operate through the trip units, and not through any external mechanism. All accessory wiring is pre-wired to secondary terminals, and no user wiring is necessary. When activated, the shunt trip (with or without lockout) and undervoltage release modules send a signal to the trip unit to energize the trip actuator and open the breaker.

MicroVersaTrip Plus™ and PM™ Trip Units

Operation of MicroVersaTrip Plus™ Trip Units

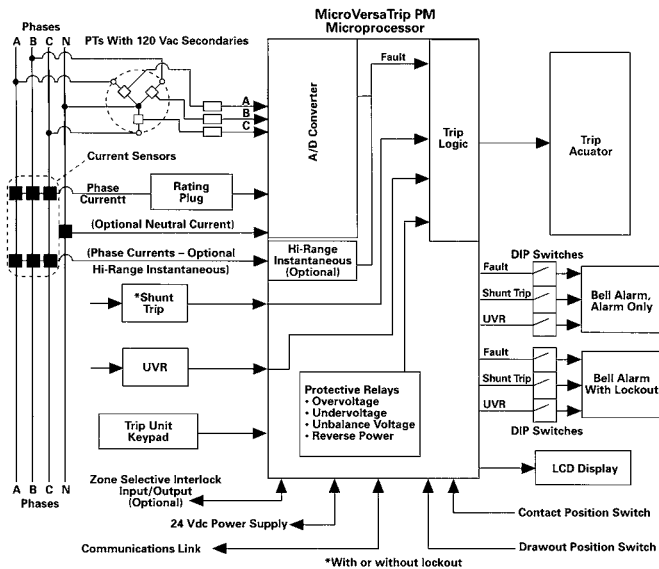

Block diagram of MicroVersaTrip Plus trip unit

MicroVersaTrip Plus units have a menu of standard and optional functions. The block diagram shows a fully configured MicroVersaTrip Plus trip unit with ground-fault protection. The current sensors are special current transformers that provide the trip unit with its operating power. Interchangeable ratings plugs act as scalars for the outputs of the current sensors, as well as establish the current rating of individual breakers. When a four-wire system is used and a ground-fault protection is called for, an external neutral sensor is necessary.

Analog current signals are converted to digital values, and are measured and compared with established trip settings in the microprocessor’s memory. Any overcurrent or ground fault condition that exceeds pre-set conditions produces a trip signal from the microprocessor to the trip actuator. The trip actuator is a low-energy, positive-action tripping device. The low-level trip signal counteracts the strength of the actuator’s permanent magnet, and allows a spring to unseat the magnet and trip the breaker.

Both the shunt trip and undervoltage release (UVR) accessories also produce trip signals to the trip actuator when energized. The user may program each of the two bell alarms, independently, to operate as a result of any combination of overcurrent (including ground fault), shunt trip and undervoltage release.

Standard And Optional Protective Functions

Standard and optional protective functions for MicroVersa-Trip Plus trip units are shown below. The breaker settings are programmed in multiples of “X” (rating plug amp values), “S” (current sensor amp rating values), “C” (the long-time setting in amps – multiply long-time setting by rating plug amp rating), and “H” (the short-time withstand rating of the breaker).

Standard

- 3-phase Ammeter
- Adjustable Long-Time (L) pickup, 0.5 – 1.0X, with four delay bands
- Adjustable instantaneous (I) pickup, 1.5 – 15X
- Overload, Short Circuit, and Short-Time local trip indicators with overload pickup warning
- Test set initiated trip

Optional Functions

- Adjustable Short-Time (S) pickup, 1.0 -9.0C and delay (3 bands) with I²t ON/OFF selection
- Adjustable Ground Fault (G) pickup, 0.2-0.6S and delay (3 bands) with I²t On/Off selection and trip indicator
- High-range instantaneous fixed at 1.0H
- Zone selective interlocking for Ground Fault or Ground Fault and Short-Time
- Defeatable Ground Fault function (non-UL)

MicroVersaTrip Plus™ and PM™ Trip Units

Long-Time Protective Functions

Long-Time Function/Current Setting (Standard)

The adjustable long-time setting is based on multiples of “X”, the rating plug amp rating. There are 11 possible setting from 50% to 100% of rating plug amps, in 5% steps. This setting establishes the current setting of the breaker, which is the current the breaker will carry continuously without tripping. Multiplying the long-time setting by the rating plug value establishes the value of “C”. For example, a breaker with a 95% long-time setting and 500 amp rating plug (x) would have a 475-amp current setting, or value of C.

(Long-time current setting (C) = (0.50 to 1.00) X rating plug (X))

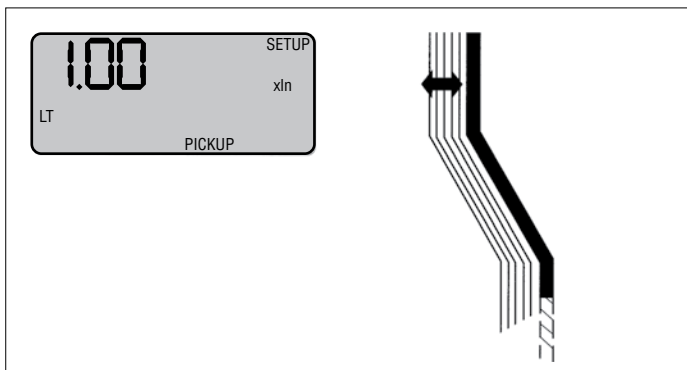

Long-time function or current setting

Long-Time Delay (Standard)

Long-time delay varies the time it will take the breaker to trip under sustained overload conditions. It permits the breaker to ride through momentary predictable overloads (e.g., motor starting) without tripping. There are 4 time bands that provide nominal delays from 3 to 25 seconds at 600 % of the breakers current setting, or value C.

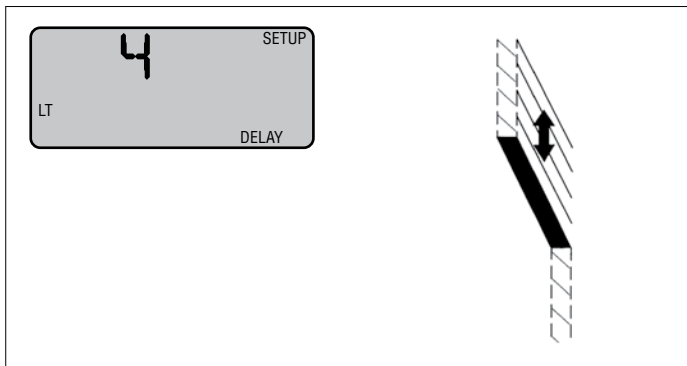

Long-time delay

Instantaneous Function (Standard)

All Power Break® II breakers have either the standard instantaneous trip function or the “high range” instantaneous function. The instantaneous trip point establishes the value of current that will trip the breaker without intentional time delay. Instantaneous trip times are 50 milliseconds, or less. Instantaneous trips are the result of severe overcurrent or short-circuit conditions, and damage to the power systems is minimized by immediate tripping. Standard settings are adjustable in increments of .5 of X of the rating plug amp value (X). See Table 19.1 for allowable values. The trip unit will limit the instantaneous trip level so that the breaker withstand rating is not exceeded.

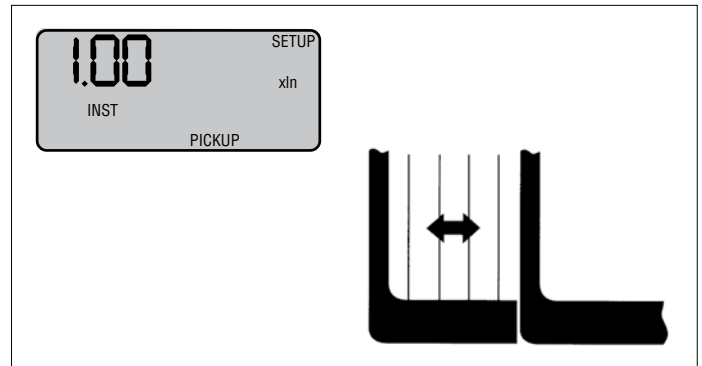

Standard instantaneous function

Short-Time Functions (Optional)

Short-Time Pickup

The short-time pickup functions controls the level of high current the breaker will withstand for a short period of time to allow downstream devices to clear faults without tripping the breaker. Settings are adjustable in increments of 50% of the breaker current setting (C). See Table 19.1 for allowable values. If the instantaneous setting is set for lower values of current than the short-time function, the instantaneous function prevails.

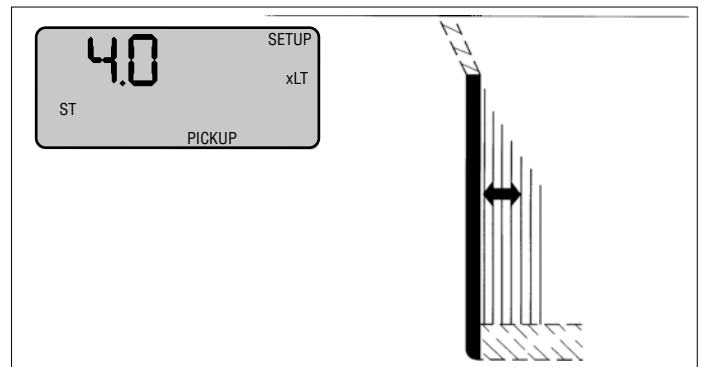

Short-time pickup function

MicroVersaTrip Plus™ and PM™ Trip Units

Table 19.1
MicroVersaTrip Plus™ And MicroVersaTrip PM Unit Characteristics

Envelope Size	Frame Max. Amp Rating	Sensor Rating (Amps) (S)	Long - Time		Short - Time	
			Current Setting (C) (Pick-Up) Multiple of Rating Plug Amps (X)	Delay ^① Seconds (4 Bands)	Pick -up (Multiple of Current Setting) (C)	Delay Seconds (3 Bands)
2000	800	200,400,800	0.5 thru 1.0 in increments of 0.05	2.4, 4.9, 9.8, 2.0	1.5 thru 9.0 in increments of 0.5	I ² T in ^④ 0.40 for all bands
	1600	800,1000,1600		2.4, 4.9, 9.8, 2.0		
	2000	2000		2.4, 4.9, 9.8, 2.0		
3000	2500, 3000	1000,2000, 2500, 3000		2.4, 4.9, 9.8, 2.0		I ² T out ^② .10, .21, .35
4000	4000	4000		2.4, 4.9, 9.8, 2.0		

Trip Unit Characteristics (continued)

Envelope Size	Adjustable Instantaneous Pick-up without ST (Multiple of Rating Plug Amps) (X)	Adjustable Instantaneous Pick-up with ST (Multiple of Rating Plug Amps) (X)	High Range Instantaneous (Multiple of Frame Short-Time Rating) (H)	Ground Fault	
				Pick-Up (Multiple of Sensor Amp Rating)	Delay ^③ Seconds (3 Bands)
2000	1.5 thru 10.0 in 0.5 increments	1.5 thru 15.0 in 0.5 increments	1.0	0.20 thru 0.60 in increments of 0.01	I ² T in ^④ 0.40 for all bands
	1.5 thru 10.0 in 0.5 increments	1.5 thru 15.0 in 0.5 increments		0.20 thru 0.60 in increments of 0.01	
	1.5 thru 10.0 in 0.5 increments	1.5 thru 15.0 in 0.5 increments		0.20 thru 0.60 in increments of 0.01	I ² T out ^② .10, .21, .35
3000	1.5 thru 10.0 in 0.5 increments	1.5 thru 13.0 in 0.5 increments		0.20 thru 0.37 in increments of 0.01	
4000	1.5 thru 9.0 in 0.5 increments	1.5 thru 9.0 in 0.5 increments		0.20 thru 0.30 in increments of 0.01	

- ① Time delay shown at 600% of current setting at lower limit of band
- ② Time delay shown at lower limit of each band. All pick-up tolerances are ±
- ③ Time delay shown at lower limit of each band. Ground fault pick-up not to exceed 1200 amps
- ④ Time delay shown at 200 % of pick-up at lower limit of band

- X = Rating plug amps**
- S = Sensor amp rating**
- C = Long-time current setting (pick-up)**
- H = Short-time rating**

MicroVersaTripPlus™ and PM™ Trip Units

Short-Time Delay

Short-time delay is always provided when short-time pickup is ordered. Short-time delay provides additional refinement in providing coordination between upstream and downstream protective devices. There are three time delays that provide delays from 100 ms to 350 ms of 1 (MIN), 2 (INT), 3(MAX).

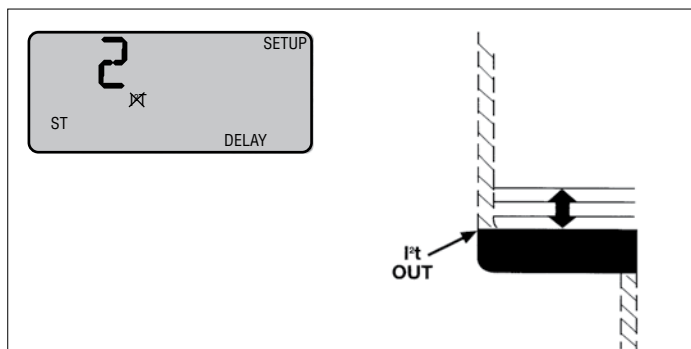

Short-time delay with I²t OUT

Selectable Short Time I²t Function

Selectable short-time I²t is always provided with the short-time option. The I²t helps the solid-state trip unit coordinate with downstream thermal magnetic devices or fuses. This function impacts the shape of short-time and short-time delay time current curves, and may be programmed either IN or OUT.

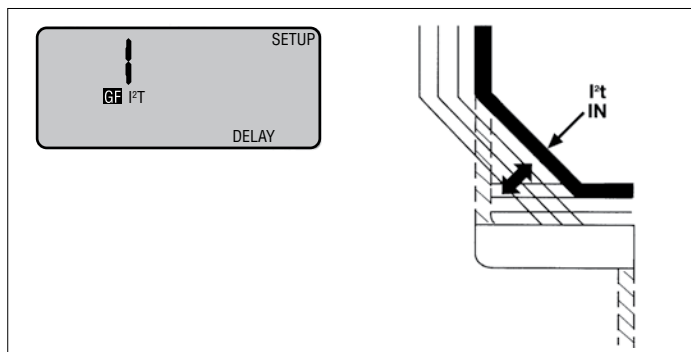

Short-time delay with I²t IN

High-Range Instantaneous (Optional)

The high-range instantaneous function is for special applications where all coordination is based on adjustments of long and short time. The instantaneous trip setting is fixed at “H” – breaker’s short-time withstand rating.

Normal Ground-Fault Protection (Optional)

Ground-Fault Protection

A ground fault is an unintentional current flow from a circuit through a conductive path to ground. Ground faults usually have intermittent or very low values of current flow, as depicted in Graph A, and are not detected by long-time overload protection.

Some ground-fault trip systems may not detect this type of fault because the intermittent nature of the fault never exceeds the trip threshold as illustrated in Graph B.

The MicroVersaTrip Plus™ and MicroVersaTrip PM™ trip units detect and integrate (add a series of arcing and intermittent current pulses) the low-level current of a ground fault. This integration function provides a memory response for ground faults to achieve preferred ground fault protection as shown in Graph C.

The NEC requires that the maximum ground-fault setting not exceed 1200 amps. Ground-fault protection includes pickup setting, ground-fault delay settings and selectable I²t function.

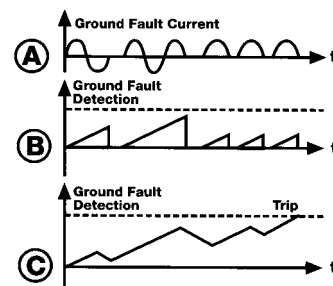

Ground fault memory circuit

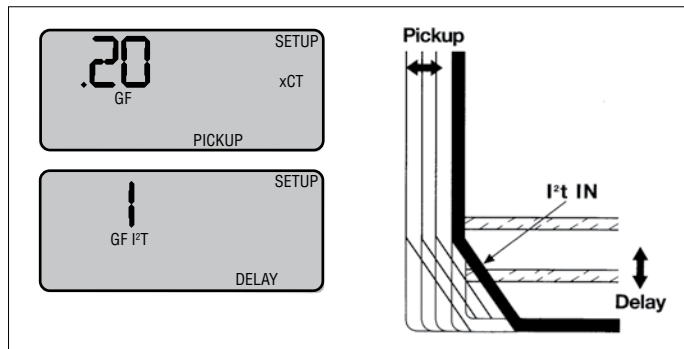

Ground fault pickup and ground fault time delay

Ground-fault pickup settings are based on multiples of S, the current sensor rating. The lowest setting is 20% of S, and the highest setting is based on current sensor amp ratings, such that the maximum setting does not exceed 1200 amps. There are three ground-fault delay bands of 1 (MIN), 2 (INT) 3 (MAX) ranging from 100 ms to 350 ms. The I²t function adds an I²t slope to the square corner of the ground-fault time current curve transition, from pickup to the constant delay bands, to improve coordination with downstream devices.

MicroVersaTripPlus™ and PM™ Trip Units

Defeatable Ground-Fault Protection (Optional)– Not UL Listed

A defeatable ground-fault protection is offered for users who want the ability to enable or disable ground-fault protection depending on special circumstances. When this type of ground-fault protection is ordered, in addition to the normal ground-fault settings, the user can enable or disable ground-fault protection during programming. To disable this kind of ground-fault protection, set the delay to OFF.

Zone Selective Interlocking (Optional)

Traditional means of obtaining selectivity between main and feeder breakers is to set the furthest downstream device with the lowest time delays, and increase time delays of upstream devices. The disadvantage of this is that upstream portions of the system must endure high values of fault current until time-out occurs.

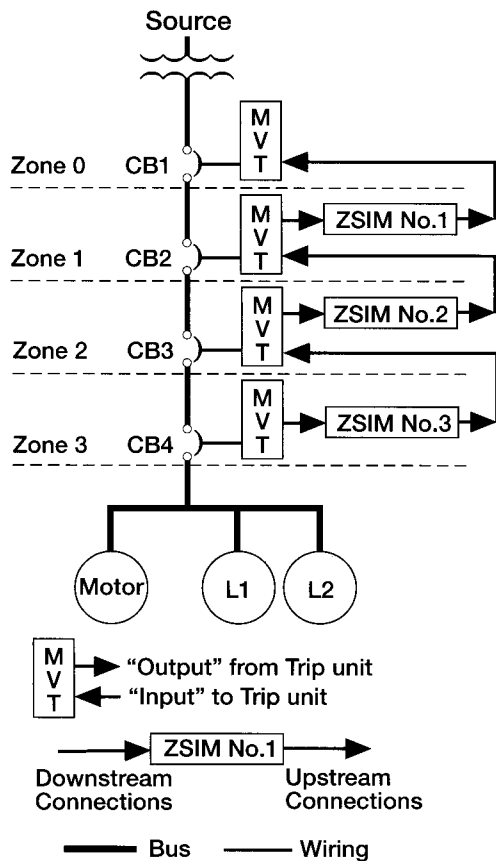

Multi-zone selective interlocking

MicroVersaTrip Plus™ and MicroVersaTrip PM™ trip units provide coordination between the first breaker and the immediate upstream breaker. When the downstream breaker detects a fault, it signals the upstream device to shift to its preset time delay band, allowing the downstream device to clear the fault. Without a signal from a downstream breaker, an upstream breaker will respond on the minimum delay band. For a fault between these two breakers, the upstream would clear the fault on the minimum delay band since no signal is being sent by the downstream breaker.

Zone Selective interlocking is available for either ground fault only, or both ground-fault and short-time functions. The zone selective interlocking feature requires a zone selective interlock module (ZSIM) catalog number TIM1. The module is an intermediate control device used between upstream and downstream circuit breakers to communicate with the short-time and ground-fault zone selective interlock functions of the MicroVersaTrip Plus and MicroVersaTrip PM units. The module requires 120/208/240 VAC, 15 VA maximum.

Operation of MicroVersaTrip PM Trip Units

MicroVersaTrip PM trip units add communications capability with remote host computers and the GE POWER LEADER™ Power Management System. In addition, the user can choose to add metering, protective relaying or both. In the block diagram (page 22) of the MicroVersaTrip PM trip unit, note that there are two additional sets of inputs – voltage inputs from each phase and a +24 Vdc input from an external power supply. Additionally, there is a communication input/output link to the POWER LEADER system.

Voltage Inputs

Voltage inputs to the MicroVersaTrip PM trip unit are required for both metering and protective relays. Voltage inputs require three delta or wye-connected potential transformers with 120 Vac secondaries, and an external voltage module that further conditions the voltage signals for use by the trip unit's microprocessor. A single set of external voltage modules can serve the requirements of up to 20 trip units.

MicroVersaTrip Plus™ and PM™ Trip Units

+24 Vdc Input

MicroVersaTrip PM trip units require an external +24 Vdc power supply to furnish power to the communication network. In addition, this power supply energizes the LCD display, so that low current values, voltage values and trip targets are displayed without use of the internal batteries. However, batteries are supplied with MicroVersaTrip PM trip units for cold set-ups and viewing targets in the event the +24 Vdc power supply is interrupted. A single +24 Vdc power supply can supply the power requirements of up to 16 MicroVersaTrip PM trip units.

Communications Output

The communications network uses a pair of shielded, twisted wires to connect individual devices to the POWER LEADER™ system. Connection distances up to 1000 ft. can be made without repeaters. All communication network wiring within the breaker is pre-wired to dedicated secondary terminals. Integration to Modbus RTU networks requires the use of a POWER LEADER Modbus Concentrator.

MicroVersaTrip PM Microprocessor

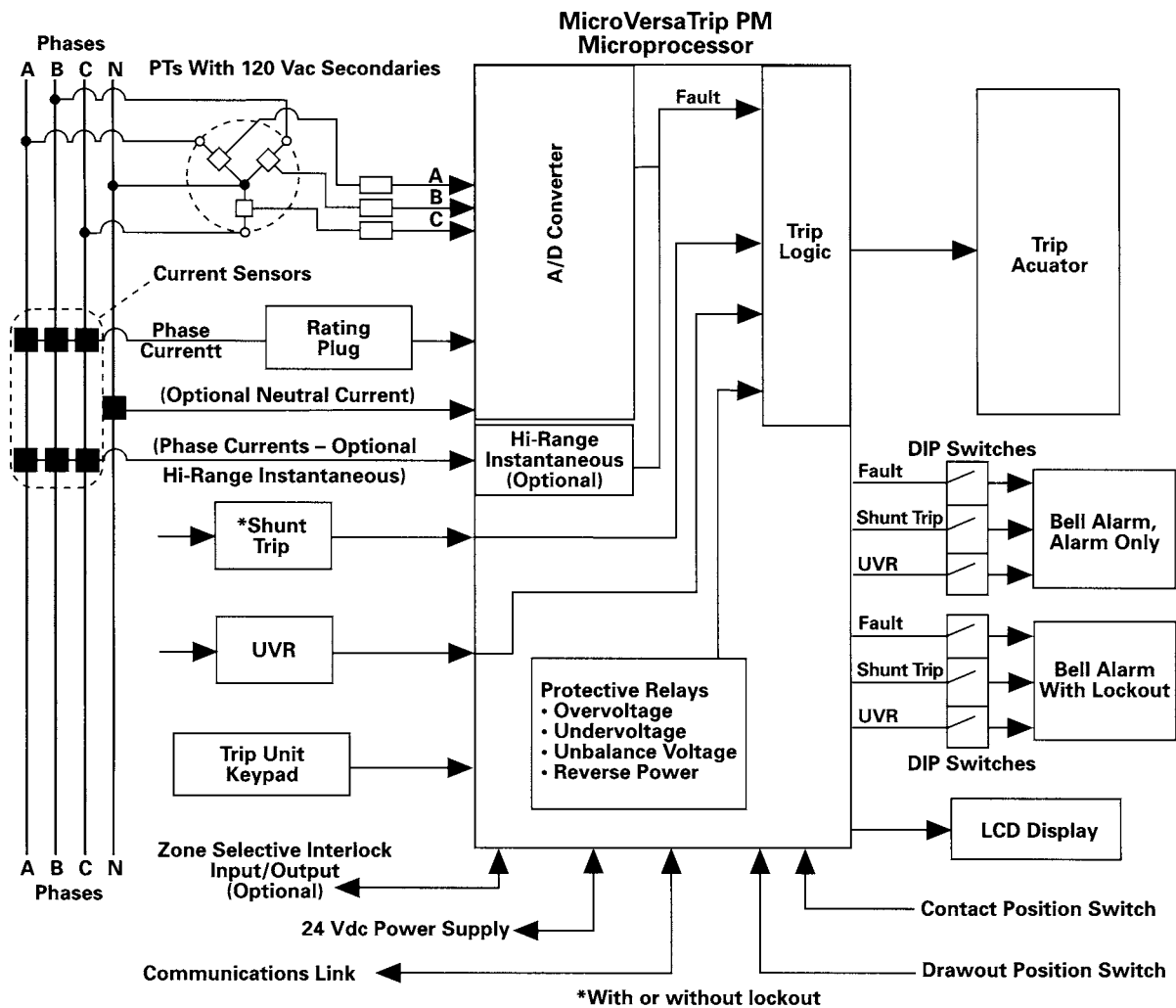

Block diagram of MicroVersaTrip PM trip unit

MicroVersaTrip Plus™ and PM™ Trip Units

Metering

When the metering function is selected, a number of standard metering parameters can be viewed on the LCD display. All of these values are communicated to the POWER LEADER™ Power Management System. The accuracy of the metering functions is constrained by the physical size of the current sensors. Consequently, all metering functions are designed for load management decisions, and are not a substitute for utility revenue metering equipment.

- **Current:** All trip units, including MicroVersaTrip Plus™, provide metering of individual phase currents. The user can select phases 1, 2, or 3. Current displays automatically shift from amps to kiloamps above 999 amps. The minimum current display resolution is in tenths of an amp (e.g., 512 A).
- **Voltage:** The metering display of four wire systems can read both line-to-neutral and line-to-line voltage display for each phase. The smallest resolution of the voltage display is one volt (e.g. 277V, or 276V).
- **Energy:** The energy display indicates the amount of real power that has passed through the breaker. The display has three-digit resolution, and automatically scales the display from kWh to MWh to GWh. Normal power flow can be selected as either load-line or line-load in the setup mode. Once normal flow is configured, energy values will accumulate in the positive direction. For certain applications where power may flow in either direction, such as tie breakers, energy may display a negative value.
- **Real power:** Real power in units of kW or MW can be shown on command on the LCD display.
- **Volt-amperes (or total power):** “Total power” or volt-amperes in units of kVA or MVA can be viewed on command on the LCD display.

- **Demand:** Demand in units of kW or MW can be displayed. The monitoring time period can be varied from 5 to 60 minutes, in increments of 5 minutes. The display provides a rolling average of power over the scheduled time interval.
- **Peak demand:** Peak demands in units of kW or MW can be displayed. This value indicates the highest power demand reached since the start of demand measurements, or since reset. The peak demand value can be reset to the present demand via the keypad.

Protective Relaying

When protective relaying functions are selected, any combination of the following protective relays can be enabled. All relay functions combine both an adjustable setpoint and an adjustable discrete (not inverse) time delay. All time delays are adjustable from 1 to 15 seconds in increments of 1 second. All tripping is performed through the trip unit. The user can configure the trip unit to activate the bell alarm only, the bell alarm with lockout, or neither, in response to a protective relay (or overcurrent/ground-fault) trip.

- **Undervoltage:** Undervoltage protection may be set from 50% to 90% of the true rms nominal voltage in increments of 1%.
- **Overvoltage:** Overvoltage protection may be set from 110% to 150% of the true rms nominal voltage in increments of 1%.
- **Voltage unbalance:** Voltage-unbalance protection compares the lowest or highest phase voltage with the other two, and initiates a trip if the difference exceeds the setpoint. True rms voltages are computed for each phase. The range of trip settings varies from 10% to 50% in increments of 1%.
- **Current unbalance:** Current-unbalance protection compares the true rms current in either the highest or lowest phase with the true rms current in the other two phases. A trip is initiated if the difference exceeds the setpoint. The range of trip settings varies from 10% to 50% in increments of 1%.
- **Power reversal:** The Power Break® II breaker may be set so that “positive” power flow can be in either direction (i.e., from line to load, or vice versa). Reverse power protection is set in units of kW. Reverse power setpoints vary from 10kW to 990kW in increments of 10kW.
- **Enable/disable relays:** To disable any of the protective relay functions, set the time delay for that function to OFF. Setting the time delay to any discrete value enables the relay.

Table 23.1 Trip Unit Metering Display Accuracy

Value	Breaker Full Scale Accuracy ^①	System Full Scale Accuracy ^②
Current, rms -A, kA	±2.5%	±2.5%
Voltage, rms -V Phase-Phase, Phase-Neutral	N/A	± 1.5%
Energy -kWh, MWh, GWh	N/A	±4.0%
Demand - kW, MW	N/A	±4.0%
Peak Demand- kW, MW	N/A	±4.0%
Real Power - kW, MW	N/A	±4.0%
Total Power - kVA, MVA	N/A	±4.0%
Frequency	N/A	±1 Hz
Time Delay	N/A	±1 sec

① Includes trip unit, breaker, current sensors and rating plug. Accuracy is based on loading range of 20% to 100% of breaker current sensor rating.

② Includes trip unit, breaker, current sensors, rating plug, plus Voltage Module (potential transformers, control power voltage conditioner). Accuracy is based on loading range of 20 % to 100 % of breaker current sensor rating.

MicroVersaTrip Plus™ and PM™ Trip Units

Programming Trip Units

All MicroVersaTrip Plus and MicroVersaTrip PM trip units for Power Break® II breakers use the same programming key-pads. All functions ordered are selectable and displayed.



Programming display and keypad

- **Function:** Selects the mode of the display (Setup, Metering or Status)
- **Select:** Chooses the next item for display. All modes have a sequential menu that allows the user to step from one function to the next.
- **Battery:** Energizes the internal battery circuit and the LCD.
- **Value:** Allows changing a setpoint, or changes a metering display from line-to-line or line-to-neutral, or select between phases 1, 2 or 3.
- **Enter:** Stores setpoint in the trip unit's non-volatile memory.

Trip Targets – Overcurrent and Ground Fault

Trip targets for protective functions use international symbols, and are shown on the LCD when in the Status mode.

- **Normal:** When all protective circuits are within normal limits, the term "OK" is visible in the LCD display.
- **Long-time trip:** The long-time trip display moves through two transitions. As the current in any phase reaches 95% of its setpoint, the word "PICKUP" begins to flash. As current increases, flashing frequency increases, until 100% of the pickup point is reached. At that moment, PICKUP remains ON, continuously, until the long-time delay times out. Once the breaker has tripped on long time, the symbol "|>" appears in the LCD display to indicate a breaker overload. In addition to this target, the display indicates the trip status with the word, "FAULT." The display shows the type of trip "LT", the phrase the fault occurred on, and the magnitude of the fault current. The trip information is displayed until cleared by the user.

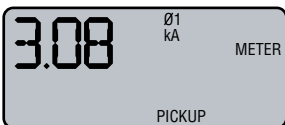

Long-time trip imminent



Breaker tripped on long time

- **Short-time and instantaneous trips:** Short-time and instantaneous trips share the same trip target. The PICKUP target is not illuminated, since the time interval between pickup and tripping are so short for either function. In the DISPLAY mode, the trip target for a short-time or instantaneous trip is "|>."



Breaker tripped on short time



Breaker tripped on instantaneous

- **Ground Fault Trip:** The trip target for a ground fault trip is illumination of the letters "GF".



Breaker tripped on ground fault

Trip Operations Counter

The trip unit stores the number of trip operations for long-time, short-time, instantaneous and ground fault. Up to 256 counts of each trip operation are stored in memory. Manual reset through the keypad is possible at any time. The electronic trip operation counter does not store shunt trip, undervoltage release or protective relay trips. An optional mechanical operations counter is available that counts each open-and-close operation of the main contacts for any reason.

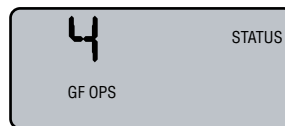

Breaker showing counter

Trip Targets – Protective Relays

Trip targets for the enabled protective relays appear in the status screen when they occur. Symbols used are:

- **Undervoltage trip** V<
- **Overvoltage trip** V>
- **Unbalanced voltage** ΔV
- **Unbalanced current** ΔI
- **Power reversal**

Trip Targets – Accessories

UVR and ST targets are displayed when a trip is caused by an undervoltage release or shunt trip accessory. The display will indicate with a flashing target and the FAULT segment does not display.

MicroVersaTrip Plus™ and PM™ Trip Units

Rating Plugs

The same interchangeable rating plugs are used in all of the MicroVersaTrip Plus™ and MicroVersaTrip PM™ trip units across the entire Power Break® II breaker product line. Rating plugs are the key devices that establish the current rating of the breaker. They provide an essential scaling function for the unit's microprocessor, and ensure maximum accuracy. They also provide an external jack for connection to an external battery pack.

Rating plugs have rejection features that allow them to be inserted only with breakers containing the correct current sensors. Rating plugs for the enhanced MicroVersaTrip Plus and MicroVersaTrip PM trip units cannot be used with Spectra RMS™ molded case circuit breakers, but are compatible with Power Break and Type AKR breakers with MicroVersaTrip Plus and MicroVersaTrip PM trip units. See Table 25.1



MicroVersaTrip rating plug

Table 25.1
Rating Plug And Current Sensor Rating

Envelope Size	Frame Max. Rating (Amps)	Sensor Rating (Amps) (S)	Sensor Rating Plug Amps (X)
2000	800	200	100, 150, 200
		400	150, 0, 225, 250, 300, 400
	800,1600	800	300,400,450,500,600,700,800
		1000	400,600,800,1000
	1600	1600	600,800,1000,1100,1200, 1600
		2000	2000
3000	2500	1000	400,600,800,1000
		2000	800,1000,1200,1500,1600,2000
		2500	1600,2000,2500
	3000	3000	2000,2500,3000
4000	4000	4000	1600,2000,2500,3000, 3600,4000

S= Sensor amp rating
X= Rating plug amps

Current Sensors

Toroidally wound current sensors are furnished for all major protective functions and for use with MicroVersaTrip PM trip units. Toroidal sensors, including a second air-core winding, are provided with the high-range instantaneous function. Current sensors are factory installed and are not changeable in the field. There are 11 current ratings for the Power Break II breaker line through 4000 amps. See Table 25.1 for current ratings. Rating plugs must be coordinated with the current sensor rating (S) listed on the face of the rating plug.



Typical toroidally wound current sensor

Accessory Configuration

Activation of the Bell Alarm – Alarm Only and Bell Alarm with Lockout are controlled by switch setting on the rear of the trip unit. To change the conditions which activate these accessories, configure the trip unit switch setting as described below.



Rear of trip unit

Table 25.2
Accessory Switch Setting

Switch	Factory Setting	Function
1	Disable	Shunt trip activates Bell Alarm – Alarm Only
2	Disable	UVR Trip activates Bell Alarm- Alarm Only
3	Enable	Protection trip activates Bell Alarm – Alarm Only
4	Disable	Shunt Trip Activates Bell Alarm/ Lockout
5	Disable	UVR trip activates Bell Alarm/Lockout
6	Enable	Protection trip activates Bell Alarm/ Lockout

Accessories

Accessories – Stationary and Drawout Breakers

The complete line of Power Break® II breaker accessories may be either factory installed or field installed to meet user needs. The electronic shunt trip (with or without lockout), the bell alarm, the bell alarm with mechanical lockout, and the undervoltage release modules drop in from the front of all breakers. One of each of the above accessory modules can be installed, and requires no field internal wiring or breaker disassembly. The accessory modules are interchangeable across all frame sizes.

Auxiliary switch modules are available in groups of 4, 8, or 12, NO/NC single-pole, double-throw (SPDT) switches. Their installation simply involves removal of breaker cover, installation of the switch module, routing of wiring and installation of the pre-wired terminal block and re-installation of the cover. Auxiliary switches are also interchangeable across all Power Break II breaker frames.

Test Kits

The test kit Catalog Number GTUTK20 is a lightweight, portable test instrument designed for field-testing of EntelliGuard TU Trip Units. The Test Kit includes the following features:

- Operation from a 100-240VAC 50/60 Hz Universal plug supply or two 9-volt alkaline batteries (batteries not supplied).
- Provides power to the trip unit for viewing and setting set-points with less than 15% load on the breaker or if the replaceable Trip Unit Battery needs replacing.
- Verification of metering (phase simulation)
- Ground Fault Testing with Ground Fault Trip Indication
- Trip test
- Temporarily disable the Ground Fault feature during single phase breaker testing

The test kit Catalog Number TVRMS2 is a portable, battery powered, test kit which provides for trip unit health checks and functional trip and no-trip test. It also provides defeat of the ground-fault function and can be used in conjunction with high-current test equipment. The test kit can be used to provide +24V power to the trip unit for cold set-up and view of trip targets. This test kit is for use with Power+™, MicroVersaTrip Plus™ and MicroVersaTrip PM™ trip units.

Electrical Operator

The electrical operator mounts inside the front cover of the manually operated breaker. This accessory can be added to any Power Break II breaker in the factory or the field to provide electrical spring charging. All breakers are pre-wired to dedicated secondary terminals for easy field installation. When electrical operation is used, a remote close solenoid and either a shunt trip or an undervoltage release accessory are required for remote closing and opening.

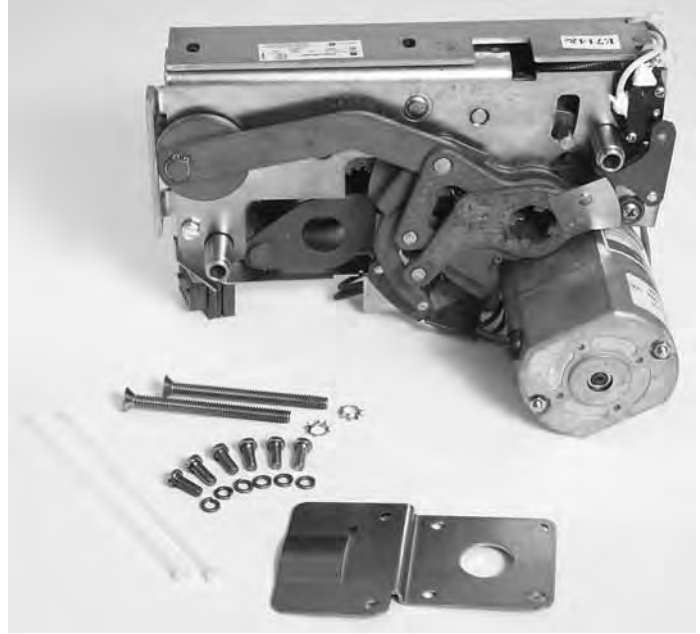

Power Break II breaker electrical operator

The electrical operator can be wired to charge automatically following a CLOSE operation, or to charge on command. A remote charge indicator switch is integral to the electrical operator. If control power is lost during the charging cycle, spring charging can be completed manually using the pump handle – no special tools or separate handles are required. However, if the charge cycle is begun manually, it must be completed manually. Any electrically operated breaker can be operated manually.

The control power required for each motor operator may be determined from Table 27.2. If several motor operators are fed from the same source, it should be sized to accommodate all operators simultaneously, especially if they are wired for automatic charge.

The voltage drop in source supply from no-load to motor full-load current should not exceed 7% of nominal voltage. Acceptable dc power supplies are: three-phase, full-wave rectified ac; battery; dc generator or any other dc source with a peak-to-peak ripple voltage of not more than 15% at rated full-load current. Operating range of electrical operator: 90% -110% of nominal rating. See wiring diagram on page 28.

Table 26.1
Electrical Operators

Catalog Number	Voltage Rating (50-60Hz)	Peak Inrush (Amps)	Operating Time (Seconds)
SPE024	24 Vdc	30.0	3
SPE048	48 Vdc	18.0	3
SPE072	72 Vdc	10.0	3
SPE125	125 Vdc	7.5	3
SPE120	120 Vac	8.0	3
SPE240	240 Vac	6.0	3

Accessories

Remote Close Solenoid

This accessory is an electrically operated solenoid which, when energized, closes the breaker. It is suitable for control interlock schemes in which manual closing capability would not be convenient or would be too slow. It is an optional accessory for a manually operated breaker, but is required for an electrically operated breaker. The remote close accessory is continuously rated and has an anti-pump feature which prevents a motor operated breaker from repeatedly closing into a fault. Closing control voltage must be removed and re-applied for each breaker closure.

This accessory consists of an integral electronic control module and the closing solenoid. When control voltage is applied to the accessory, the electronic control module applies a single pulse of current to the solenoid for approximately 0.25 seconds to drive the solenoid before shutting the current off to a level of approximately 10mA. Voltage must be removed and re-applied to reclose the breaker, thereby providing the anti-pump feature.

This pulse approach allows the accessory to be continuously rated. Control voltage must be removed for 2.5 seconds and then reapplied each time the solenoid is to be energized. Removal of the voltage for significantly less than 2.5 seconds will not reset the electronic control module and prevent the solenoid from being energized. Applied control voltage (closed circuit voltage at breaker terminals 34 and 16) must be 85% to 110% of nominal. The solenoid will not energize if voltage is ramped up to the acceptable range. Three-cycle closing time, at nominal voltage, is standard and fulfills the requirements of generator synchronizing.

Table 27.1
Remote Close Solenoid

Catalog Number	Voltage Ratings	Peak Inrush Current (Amps)
SPRCS024	24 Vdc	13.2
SPRCS048	48 Vdc	6.6
SPRCS072	72 Vdc	5.0
SPRCS125	125 Vdc	3.5
SPRCS120	120 Vac	3.0
SPRCS240	240 Vac	2.0

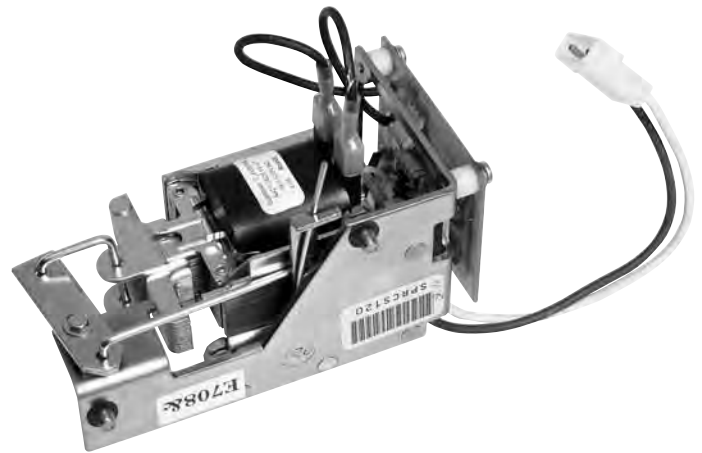

Remote close solenoid

Table 27.2
Control Power Requirements For Motor Operators

Rated Voltage (50-60 Hz)	Operating Voltage Range	Peak Inrush (RMS Amps)	Peak Full Load Amps	Average Amps	Charge Time (Sec) [Ⓛ]	Recommended Fuse (Slo-blow)
24 Vdc	21 - 27 Vdc	30.0	14.0	11.0	3	12A, 125V
48 Vdc	41 - 53 Vdc	18.0	7.0	4.5	3	7A, 125V
72 Vdc	62 - 80 Vdc	10.0	4.5	3.0	3	5A, 125V
120 Vac	102 - 132 Vac	7.5	4.0	2.0	3	4A, 125V
125 Vdc	106 - 137 Vdc	8.0	2.5	1.8	3	2.5A, 125V
240 Vac	204 - 264 Vac	6.0	2.5	1.0	3	2.5A, 250V

[Ⓛ] Charging time apply to normal voltage only; times may vary at maximum and minimum voltage.

Accessories

Wiring Diagrams For Remote Operation

For proper operation, the electrical circuit should be wired as shown in the diagram. All customer-supplied contacts should be rated for the currents identified for both the electric

operator and the remote close solenoid. If momentary contact switches are used, the minimum duration of contact closure must be 83 milliseconds.

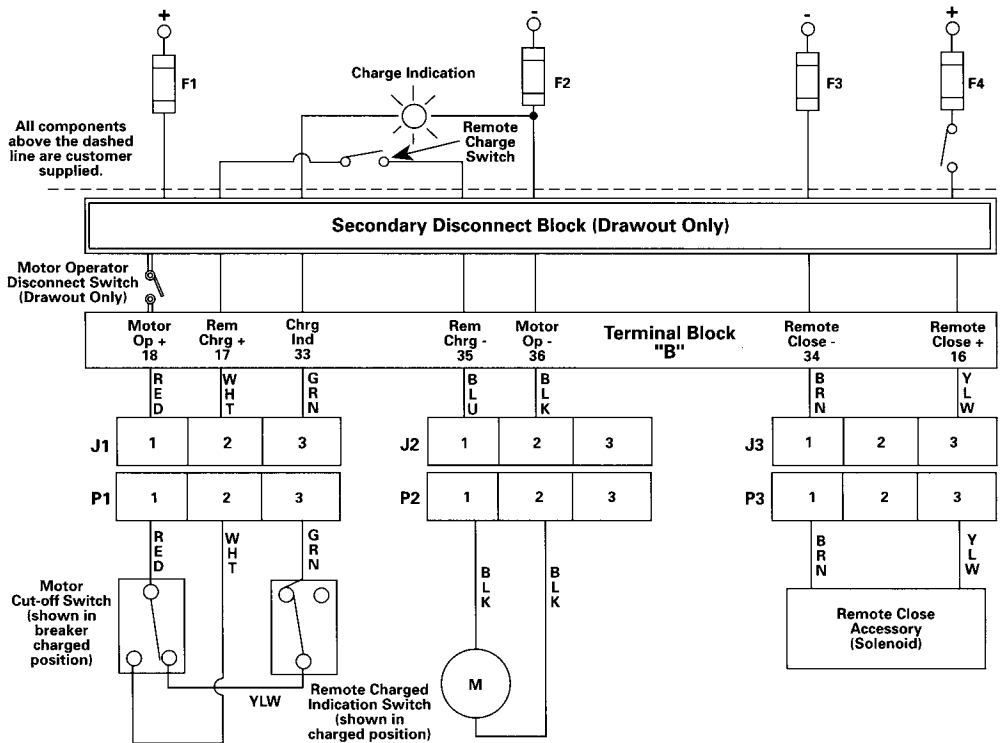

Ac or dc power wiring diagram, remote operation

Shunt Trip

The shunt trip accessory is an electronic module which provides remote control capability to open the circuit breaker. Breaker opening time is 50 milliseconds. When activated, the shunt trip module sends a signal to the trip unit to open the breaker. This allows the trip unit to record, display, distinguish and communicate (in EntelliGuard® TU and MicroVersaTrip PM™ trip units) that the opening event was initiated by the shunt trip device. The shunt trip is continuously rated and requires no cut-off switch. When energized, the shunt trip supplies +24 Vdc power to the trip unit to power the display.

Shunt trip modules are available in a wide range of voltages (from 24 to 250 Vdc, and 24 to 240 Vac). They meet UL requirements for operation at 55% of rated ac or 75% of rated dc voltage, making this device suitable for use with Class 1 ground-fault protective devices. Shunt trip modules are also available for 480 Vac and 600 Vac control power. A 50 VA control power transformer, which mounts externally from the breaker, is required and supplied with these accessories. These transformers provide an output of 120 Vac, 50/60 Hz, to the supplied shunt trip (with or without lockout). (See outline drawing in the Physical Data section.)



Shunt trip module

Table 28.1
Shunt Trip Module

Catalog Number	Voltage Rating (50-60 Hz)	Maximum Operating Voltage (Volts)	Peak Inrush Current (AC Amps)	Nominal Input Current (AC RMS mA)
SPST012	12 Vdc	13.2	3.0	200
SPST024	24 Vac/dc	26	1.5	140
SPST048	48 Vac/dc	53	1.5	110
SPST120	120Vac/125 Vdc	132	1.5	85
SPST208	208 Vac	228	1.5	50
SPST240	240Vac/250 Vdc	264	1.5	40
SPST 480	480 Vac	528	3.0	65
SPST 600	600 Vac	660	3.0	65

Accessories

Shunt Trip With Lockout

The shunt trip with lockout is similar to the regular shunt trip. When energized, the shunt trip with lockout module sends a signal to the trip unit to open the breaker. In addition, when continuously energized with the breaker open, a plunger in the module acts upon the mechanism, blocking manual and electric closing by preventing mechanism spring discharge. To close the breaker, de-energize the module for 250 ms. Because the breaker movable contacts are restrained and cannot momentarily touch the stationary contacts, the mechanism remains “kiss-free”. This feature is especially important in main-tie-main schemes or generator circuits.

Table 29.1
Shunt Trip Module with Lockout

Catalog Number	Voltage Rating (50-60 Hz)	Maximum Operating Voltage (Volts)	Peak Inrush Current (AC Amps)	Nominal Input Current (AC RMS mA)
SPSTL012	12 Vdc	14	19	300
SPSTL024	24 Vac/dc	26	15	300
SPSTL048	48Vac/dc	53	7.5	200
SPSTL120	120Vac/125 Vdc	132	3	80
SPSTL208	208Vac	228	1.9	60
SPSTL240	240 Vac/250 Vdc	264	1.5	45
SPSTL480	480 Vac	528	3	65
SPSTL600	600Vac	660	3	65

Bell Alarm (Alarm Only)

The bell alarm module is used to signal breaker “tripped” status to other accessories (e.g. external alarm devices, indicating lights, relays, or logic circuits) for remote indication and interlocking functions. The switch is configurable by means of rear-mounted DIP switches on the EntelliGuard® TU and MicroVersaTrip Plus™ and PM™ trip units. The bell alarm can be made to operate in response to an overcurrent (including ground fault) or protective relay trip and/or a shunt trip operation, and/or operation of the undervoltage release module. It is not actuated as a result of normal breaker “ON/OFF” operation. For the Power+™ trip unit, the bell alarm operates only when an overcurrent (including ground fault) trip occurs.

This module provides a visual, mechanical pop-out target which protrudes through the face of the circuit breaker door when it operates. The bell alarm may be reset manually by depressing the mechanical target, or automatically by closing the breaker.

The bell alarm is provided with one SPDT switch with control power duty contacts as shown in Table 29.2.



Bell alarm

Table 29.2
Bell Alarm Module

Catalog Number	AC Ratings	DC Ratings
SPBAA240	6 A @ 240 Vac	0.5 A @ 125 Vdc 0.25 A @ 250 Vdc
SPBAA600 ^①	6A @ 600 Vac	0.5 A @ 125 Vdc 0.25 A @ 250 Vdc

^① 600 Vac module not UL listed

Accessories

Bell Alarm With Lockout

The bell alarm with lockout module combines both the bell alarm and a manual lockout function. The bell alarm switch operates identically to the standard bell alarm module, except that the mechanical pop-out target must be manually reset before the breaker can be closed.

Operation of the bell alarm with lockout module can be independently set by means of setting the DIP switches at the rear of the EntelliGuard® TU and MicroVersaTrip Plus™ and PM™ trip units. For the Power+™ trip unit, the bell alarm with lockout module operates only when an overcurrent (including ground fault) trip occurs. Current ratings of the single SPDT switch are identical to the bell alarm module.



Bell alarm with mechanical reset lockout

Table 30.1
Bell Alarm with Lockout Module

Catalog Number	AC Ratings	DC Ratings
SPBAL240	6 A @ 240 Vac	0.5 A @ 125 Vdc 0.25 A @ 250 Vdc
SPBAL600 [ⓐ]	6 A @ 600 Vac	0.5 A @ 125 Vdc 0.25 A @ 250 Vdc

ⓐ 600 Vac module not UL listed

Undervoltage Release Module

The undervoltage release is an electronic module used to open the circuit breaker when the monitored voltage drops below 35-60% of its rated value. The undervoltage release “resets” when the monitored voltage is re-established allowing the circuit breaker to reclose (the sealing voltage of the UVR is 60-85% of its rated voltage).



Undervoltage release module

An undervoltage release trip operation is produced by the EntelliGuard® TU and Power+, MicroVersaTrip Plus or MicroVersaTrip PM trip unit in response to a signal from the undervoltage release module. This allows the trip unit to record, display, distinguish and communicate (in EntelliGuard® TU and MicroVersaTrip PM trip units) that the breaker opening event was due to undervoltage release. Operation of the undervoltage release module will prevent breaker contact closure, i.e. “kiss-free” operation. When energized, the undervoltage release supplies +24 Vdc power to the EntelliGuard® TU and MicroVersaTrip Plus and PM trip units to power the display.

The undervoltage release module is available in a wide range of control and power system voltages ranging from 12 Vdc to 600 Vac. Undervoltage release modules used with 480 Vac and 600 Vac control power are supplied with a 50 VA control power transformer which mounts externally from the breaker. These transformers provide an output of 120 Vac, 50/60 Hz, to the UVR modules. (See outline drawings in Physical Data Section.)

Table 30.2
Undervoltage Release Module

Catalog Number	Voltage Ratings Current (50-60 Hz)	Peak Inrush Current (Amps)	Nominal Input (mA)
SPUV012DC	12 Vdc	16	200
SPUV024DC	24 Vdc	15	140
SPUV048DC	48 Vdc	7.5	70
SPUV125DC	125 Vdc	3	30
SPUV250DC	250 Vdc	1.5	15
SPUV024AC	24 Vac	15	370
SPUV048AC	48 Vac	7.5	210
SPUV120AC	120 Vac	3	80
SPUV208AC	208 Vac	1.9	60
SPUV240AC	240 Vac	1.5	45
SPUV480AC	480 Vac	2	50
SPUV600AC	600 Vac	2	60

Time Delay Module for UVR

The time delay module prevents nuisance tripping due to momentary loss of voltage. Cat. No. SPUVTD has 0.1 to 1.0 seconds delay. The module has 120 Vac input and 125 Vdc output and must be used with the 125 Vdc UVR (Cat. No. SPUV125DC).

Accessories

Auxiliary Switch

An auxiliary switch signals the circuit breaker's primary contact position (i.e. OPEN or CLOSED) to other devices, such as indicating lights, relays or logic circuits. This enables the user to provide remote indication, interlocking or control operations as a function of breaker primary contact position. The auxiliary switch operation is independent of the method by which the breaker is opened or closed. The auxiliary switch does not distinguish between a "tripped" or "open" condition. The auxiliary switch contacts follow the main breaker contacts on opening and precede them on closing.



Auxiliary switch with pre-wired secondary terminals (Drawout shown)

Auxiliary switch modules are available with 4, 8, or 12 NO/NC (SPDT) switches for control power duty ac/dc ratings. When ordered for field installation, an auxiliary switch module comes pre-wired to its own terminal board, which mounts with one screw to the left side of the breaker. All secondary terminals are dedicated, so there is no confusion in wiring to a 4, 8, or 12-switch module. A separate accessory for drawout breakers come pre-wired to the secondary disconnect.

Table 31.1

Auxiliary Switch

Catalog Number ^①	Number of Contacts	AC Ratings	DC Ratings
SPAS240AB4 SPAS240AB4D	4	6A@240 Vac and 120 Vac	0.5A@ 125 Vdc 0.25 @ 250 Vdc
SPAS240AB8 SPAS- 240AB8D	8	6A@ 240 Vac and 120 Vac	0.5A@ 125 Vdc 0.25 @ 250 Vdc
SPAS240AB12 SPAS- 240AB12D	12	6A@240 Vac and 120 Vac	0.5A@ 125 Vdc 0.25 @ 250 Vdc
SPAS600AB4 ^② SPAS600AB4D ^②	4	6A@600 Vac	0.5A@ 125 Vdc 0.25 @ 250 Vdc
SPAS600AB8 ^② SPAS600AB8D ^②	8	6A@600 Vac	0.5A@ 125 Vdc 0.25 @ 250 Vdc

① "D" suffix for drawout breaker accessory.

② 600 Vac Modules not UL Listed

Limited Access "Pushbutton Cover"

This accessory limits access to "ON/OFF" control of a breaker to authorized personnel. The pushbutton cover accessory consists of transparent hinged covers that can be individually sealed to the limited access assembly. Both the "ON" and "OFF" button covers can be pilot drilled to allow use of a 1/8" rod to operate either one or both pushbuttons. The catalog number of this accessory is: SPPBCOVER.



Limited access pushbutton cover assembly

Mechanical Operations Counter

The mechanical operations counter is mounted behind the front cover of the breaker, and it is viewable through a rectangular knockout window opening in the breaker cover. It is a five-digit non-resettable counter which is actuated each time the breaker is opened by any means. Together with the fault operations counters stored in EntelliGuard[®] TU and MicroVersaTrip Plus[™] and MicroVersaTrip PM[™] trip unit memory, a complete history of breaker operations is available to the user. The catalog number of this accessory is : SPCOUNTER.



Mechanical operations counter

Accessories

Padlock Device (Standard)

Padlocking devices are standard on all Power Break® II Circuit breakers. When the breaker is in the open position, and the padlock device is raised at least 1/4", the breaker cannot be closed mechanically or electrically. The device accepts up to three padlocks with 1/4" to 3/8" diameter shanks. The padlock device meets the EUSERC requirement for padlocking.



Integral padlock device

Key Interlock Provisions

The key interlock provision enables the user to mount a one-to four-cylinder, narrow-faced, Kirk-type FN customer-supplied lock on the face of the breaker. The key interlock provision works in conjunction with the padlock device. The key interlock extends a lever through the padlock device when the key is turned to the key removal or bolt extended position.



Key interlock installed on front of the breaker

Table 32.1
Key Interlock Provisions

Catalog Number	Number of Locks	Kirk Key lock Cat. Number	Superior Cat. Number
SPK4	1	KFN00001-①	S105827Y
SPK4	2	KFN00002-①	S105828Y
SPK4	3	KFN00003-①	S105829Y
SPK4	4	KFN00004-①	S105827-4Y

① Final digit may be 0, 1, 2, or 3 depending on number of key removal positions.

Door Interlock

The door interlock provides interlocking of the circuit breaker compartment's hinged door so that the breaker must be in the "OFF" position before the door can be opened. The door interlock is defeatable with a small tool to allow authorized access. The catalog number of the door interlock is: SPDIL.



Door interlock

Accessories

Neutral Current Sensors

When the ground-fault option is selected in a trip unit, and a single phase 3-wire or a 3 phase four-wire power system (e.g., 120/208 Vac or 277/480 Vac) is used, an external neutral sensor must be inserted in the neutral lead of the power system to complete the ground-fault protective circuit.

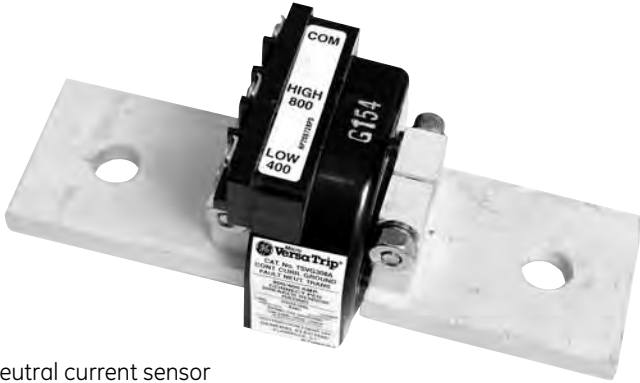

Neutral current sensor

Table 33.1
Neutral Current Sensors^①

Breaker Frame (Amps)	Circuit Breaker Sensor Rating (Amps)	Neutral Sensor Rating or Tap Setting (Amps)	Catalog Number
800	200	200	TSVG302
	400	400/200	TSVG304A
		600/300 ^②	TSVG306A
	800	800/400	TSVG308A
1600	1000	800/400 ^②	TSVG808A
		1000/500	TSVG810A
		1200/600 ^②	TSVG812A
		1600/1000	TSVG816A
2000	2000	2000/1200	TSVG820A
3000	1000	800/400 ^②	TSVG808A
		1000/500	TSVG810A
		1200/600 ^②	TSVG812A
		1600/1000 ^②	TSVG816A
	2000	2000/1200	TSVG820A
3000	2500	2500/1800	TSVG825A
	3000	3000/2400	TSVG830A
4000	4000	4000/3000	TSVG940A

① Match neutral current sensor rating (or tap setting) to circuit breaker sensor rating.

② For use with multiple-source ground fault protection schemes. rating does not match MicroVersaTrip® Trip Unit sensor.

Additional Accessories – Stationary Breakers General Purpose, Wall Enclosures

General Purpose, NEMA 1 enclosures are available for Power Break® II breakers with neutrals for 800-2000 amps. These units are UL Listed for service entrance use for single phase three-wire, or 3-phase four-wire power systems through 600 Vac. Enclosures are provided with breaker mounting studs and lugs. Enclosures, breakers and neutrals are ordered and shipped separately, unassembled. These units are suitable for use in 65 kA (max.) rms symmetrical systems.

Table 33.2
Enclosures And Field Installed Neutrals

Catalog Number	Frame Size	Field Installed Neutral Catalog Number
SPB08W	800 A	TNT800
SPB16W	1600 A	TNT1600
SPB20W	2000A	TNT2000

Accessories

Lug Adapter Kits

Pre-mount to bus structure allowing cabling or bussing to be completed prior to breaker mounting. Accept either lugs or crimp-type connector terminals. Catalog includes adapter and hardware for either a three-pole line-side, or a three-pole load-side connection. (Lugs not included)

Table 34.1
Lug Adapter Kits

Circuit Breaker Frame Size (Amps)	Suitable For Use With up to:	Catalog Number
800	3 TPLUG108 Lugs or 3 Crimp Lugs ^① Per Pole	TPLUA08
1600	6 TPLUG108 Lugs or 6 Crimp Lugs ^① Per Pole	TPLUGA16 ^②
2000	6 TPLUG108 Lugs or 6 Crimp Lugs ^① Per Pole	SPLUGA20 ^②

^① Anderson VCEL-075-12H1 or equivalent.

^② T-Studs – SP20FCA – included with adapter.

T-Studs

T-Studs mount directly to the breaker, and can be rotated for either vertical or horizontal busbar connection. Catalog numbers cover one stud. Both copper and aluminum T-studs are tin-plated.

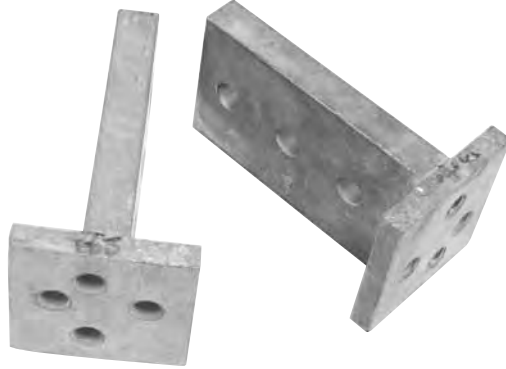

800- amp, Cat. No. SP08FCA and 1600 – 2000-amp, Cat. No. SP20FCA aluminum T- Studs

Table 34.2
T-Studs

Circuit Breaker Frame Size (Amps)	Max. Rating (Amps)	Catalog Number	
		For Front Connected Breaker	For Back Connected Breaker
800	800	SP08FCA ^③ SP08FCC ^⑤	—
2000	1600-2000	SP20FCA ^③ SP20FCC ^⑤	—
2500	2000 2500	SPS20FCA ^③ SPS25FCC ^⑤	SPS20BCA ^{③④} SPS25BCC ^{④⑤}
3000	3000	SPS30FCC ^⑤	^{⑤⑥}
4000	4000 4000	SPS40FCC ^⑤ SPS40LFCC ^{⑤⑦}	— —

^③ Aluminum

^④ Six T-studs supplied at no charge when ordered with breaker.

^⑤ Copper

^⑥ Supplied with integral T-Stud.

^⑦ Extra long stud. Alternate with SPS40FCC for ease of installation.

Accessories

Mechanical Interlocks (“Walking Beam”) For Stationary Breakers

Mechanical interlocks are mechanical devices used to prevent two adjacent circuit breakers from both being in the “ON” or closed position at the same time. The interlock permits both breakers to be in the “OFF” position or open position while allowing either or both to be charged.

Table 35.1
Mechanical Interlocks

Maximum Current Envelope Size Rating (Amps)	Catalog Number
2000	SPWB20
3000	SPWB30
4000	SPWB40

Lug Kits

Lug kits accept copper and aluminum wire and are suitable for direct mounting to the breaker, except in the case of TSLUG kits, T-studs must also be used.

Table 35.2
Lug Kits

Circuit Breaker Frame Size (Amps)	Max Rating (Amps)	Catalog Number	Lugs Per Kit	Max. Cables Per Pole	Wire Range (Footnote)
800	400	TPLUG106	1	1	②
	600	TPLUG206	1	2	②
	800	TPLUG308	1	3	③
	800	TPLUG108①	1	3	④
1600	1600	TPLUG408	1	4	⑤
		TPLUG108①	1	6	④
2000	2000	TPLUG108①	1	6	④
3000 [Ⓣ]	800	TSLUG08	9	3	⑥
	1200	TSLUG12	12	4	⑥
	1600	TSLUG16	15	5	⑥
	2000	TSLUG20	18	6	⑥
	2500	TSLUG25	21	7	⑥
4000	3000	TSLUG30	27	9	⑥
	4000	TSLUG40	33	11	⑥

① For use with adapter kit only.

② #2 AWG-600 kcmil Cu/Al.

③ 300-750 kcmil Cu/Al.

④ #3/0 AWG – 800 kcmil Cu/Al.

⑤ 500-800 Kcmil Cu/Al.

⑥ 3/0- 800 kcmil Cu/Al.

Ⓣ For back connected 3000A: T-Stud integral with breaker.

Additional Accessories – Drawout Breakers Substructures

Substructures are available for both standard and Hi-Break® Power Break® II breakers. Holes are provided for bolting on a shelf or supports. Holes are also provided in the primary stabs for bolting to busbars or terminal lugs. A special speed wrench-style racking tool is provided for racking a breaker in and out of the substructure.

Table 35.3
Substructures

Circuit Breaker Frame Size (Amps)	Standard Break Catalog Number	Hi-Break Catalog Number
800	SPSDOS08	SPHDOS08
1600	SPSDOS16	SPHDOS16
2000	SPSDOS20	SPHDOS20
2500	SPSDOS25	SPHDOS25
3000	SPSDOS30	SPHDOS30
4000	SPSDOS40	SPHDOS40

Accessories

Secondary Disconnects

Control wiring is connected through drawout secondary disconnects in the “TEST” and “CONNECTED” positions only. Up to 72 control circuits are possible through (36) position plug-style secondary disconnect blocks factory mounted to each side of drawout breakers. One substructure disconnect (SPDOSD36S) must be ordered for each breaker. An additional block is required for auxiliary switches.

Table 36.1
Secondary Disconnects

Catalog Number	Location
SPDOSD36S	Substructure ^①
SPDOSD36B	Breaker ^②

① One must be ordered for each substructure when accessories or communications are used. When auxiliary switches are used, along with any other electrical accessory or communication, two disconnects must be ordered.

② Order for replacement only. Included with drawout breaker.

Shutters

Shutters prevent unintentional contact with potentially live primary disconnect stabs when a breaker is racked out of an energized switchboard compartment.

Table 36.2
Shutters

Frame Size	Catalog Number
800-2000A	SPDSS20
3000A	SPDSS30
4000A	SPDSS49

Racking Padlock

The catalog number TDOPC racking padlock provides a means for the user to prevent racking tool engagement, thereby preventing movement of the breaker between the Disconnected, Test and Connected positions.

By-Pass Switch

Provides control circuit continuity or downstream signaling when drawout is engaged. The switch can be used as an interlocking means to ensure the remote close solenoids cannot be energized until the drawout breaker primaries are fully engaged. The switch assembly mounts on the stationary frame, and the actuator to the carriage. Switch contacts are rated at 10A at 600Vac, 0.75A at 125Vdc and 0.25A at 250Vdc.

Table 36.3
By-Pass Switch

Catalog Number	Number of Switch Elements
TDOBP2L	2 NO/2 NC
TDOBP4L	4 NO/4 NC
TDOBP6L	6 NO/6 NC

Racking Tool

The racking tool is a drive wrench with a square ½” socket that engages the racking mechanism of the drawout breaker. The catalog number is TDORT. Note that one racking tool is supplied with each group of five drawout breakers at no charge.

Mechanical Interlocks for Drawout Breakers

Mechanical interlocks for drawout breakers provide the same function as those for stationary breakers, except they are used with two drawout breakers, mounted on a common compartment centerline, in either the same vertical section or adjacent vertical sections.

Table 36.4
Mechanical Interlocks

Envelope Size	Catalog Number
800-2000	SPDOWB20
2500-4000	SPDOWB40

Lifting Bar

The lifting bar (TBOLB) provides a means of safely lifting a drawout circuit breaker. A chain hook should be attached to the central hole in the lifting bar.

Position Switch

Provides positive indication when the drawout breaker or switch primary contact fingers have been fully disengaged from the main bus connections. Switch contacts change state only after the primary fingers are fully disconnected when the breaker is being moved from the CONNECTED position through the TEST position and into the DISCONNECTED position.

May be used as part of a safety interlocking system in addition to the visual indicator on the drawout substructure. The Position Switch accessory does not indicate either the TEST or CONNECTED position. The switch assembly mounts on the stationary frame and the actuator mounts to the carriage. Switch contacts are rated at 10A at 600Vac, 0.75A at 125Vdc, and 0.25A at 250Vdc.

Number of Switch Elements	Product Number	List Price
5 NO/2NC	SDOPS2L	\$177.00
4 NO/4 NC	SDOPS4L	\$256.00
6 NO/6NC	SDOPS6L	\$336.00

Catalog Numbers

This section contains the nomenclature system for Power Break® II circuit breakers, EntelliGuard® TU, Power+™, MicroVersaTrip Plus™ and MicroVersaTrip PM™ trip units plus the interchangeable rating plugs. The catalog number shown is just an example. See the tables that follows for specific selections and their corresponding digits.

Digit	S	S	D	2	B	5	X	2	U	4	1	0	0	0	H
Step	1	2	3	4	5	6	7	8	9	10	11	12	13	14	15
	Circuit Breaker	Interrupting Capacity	Construction	Frame	Trip Unit	Current Sensor	Options	Overcurrent Protection	Rating Plug	Shunt Trip	Alarm & Kirk Key	UVR, Padlock	Elect. Oper, PB cover, Hidden On	Solenoid, Interlock, Counter	Aux. Switch, Stationary / Drawout, Trimplate

Step 1. Circuit Breaker

Breaker Type	Digit
Power Break® II	S

Step 2. Interrupting Capacity

Interrupting Type	Digit
Standard	S
High Break	H

Step 3. Construction

Construction Type	Digit
Stationary Front	F
Stationary Back	B
Drawout	D

Step 4. Frame Ratings

Frame Rating	Digit
800A	1
1600A	2
2000A	3
2500A	4
3000A	5
4000A	6

Step 5. Trip Unit

Trip Unit Type	Digit
Power+	D
Enhanced MVT®	B
Enhanced MVT PM	C
EntelliGuard® TU	G
Switch w/PP	Y
Switch w/GTU	X

Step 6. Current Sensor

Sensor Rating	Digit
200A	1
400A	2
800A	3
1000A	4
1600A	5
2000A	6
2500A	7
3000A	8
4000A	9

Catalog Numbers

Step 7. Trip Unit Type & Features

Power+

Digit	X	D	E	F	G	H	J	K	L	M	N	P
Metering	None	Full	Full	Full	Full	Full	Current	Current	Current	Full	Full	Full
RELT	None	RELT	RELT	RELT	RELT	RELT	None	RELT	RELT	RELT	RELT	RELT
Communication	None	Modbus	Profibus	None	Modbus	Profibus	None	Modbus	Profibus	None	Modbus	Profibus
Relays	None	None	None	YES	YES	YES	None	None	None	None	None	None
ZSI	None	None	None	None	None	None	GF&ST	GF&ST	GF&ST	GF&ST	GF&ST	GF&ST

Power+ (continued)

Digit	Q	R	V	W	Y	Z	1	2	3	4	5	6
Metering	Full	Full	Full	Current	Current	Current	Full	Full	Full	Full	Full	Full
RELT	RELT	RELT	RELT	None	RELT	RELT	RELT	RELT	RELT	RELT	RELT	RELT
Communication	None	Modbus	Profibus	None	Modbus	Profibus	None	Modbus	Profibus	None	Modbus	Profibus
Relays	YES	YES	YES	None	None	None	None	None	None	YES	YES	YES
ZSI	GF&ST	GF&ST	GF&ST	GF&ST&I	GF&ST&I	GF&ST&I	GF&ST&I	GF&ST&I	GF&ST&I	GF&ST&I	GF&ST&I	GF&ST&I

Enhanced MVT

Digit	X	A	B	C	D	E	F	G	H	J	K	L
Metering	Current	Current	Current	Current	Current	Current	Full	Full	Full	Full	Full	Full
Communication	None	None	None	CNET	CNET	CNET	CNET	CNET	CNET	CNET	CNET	CNET
Relays	None	None	None	P	P	P	None	None	None	P	P	P
ZSI	None	GF	GF&ST	None	GF	GF&ST	None	GF	GF&ST	None	GF	GF&ST

Enhanced MVT PM

Digit	X	A	B	C	D	E	F	G	H	J	K	L
Metering	Current	Current	Current	Current	Current	Current	Full	Full	Full	Full	Full	Full
Communication	None	None	None	CNET	CNET	CNET	CNET	CNET	CNET	CNET	CNET	CNET
Relays	None	None	None	P	P	P	None	None	None	P	P	P
ZSI	None	GF	GF&ST	None	GF	GF&ST	None	GF	GF&ST	None	GF	GF&ST

EntelliGuard TU

Digit	X	A	B	C	E	F	H	J	K	L	M	N
Metering	Current	Current	Current	Current	Full	Full	Full	Full	Current	Current	Current	Current
RELT	None	RELT	RELT	None	RELT	None	RELT	None	None	RELT	RELT	None
Communication	None	None	Modbus	Modbus	Modbus	Modbus	Modbus	Modbus	None	None	Modbus	Modbus
Relays	None	None	None	None	None	None	YES	YES	None	None	None	None
ZSI	None	None	None	None	None	None	None	None	GF&ST	GF&ST	GF&ST	GF&ST

EntelliGuard TU (continued)

Digit	Q	R	W	Y	Z	1	2	3	5	6	8	9
Metering	Full	Full	Full	Full	Current	Current	Current	Current	Full	Full	Full	Full
RELT	RELT	None	RELT	None	None	RELT	RELT	None	RELT	None	RELT	None
Communication	Modbus	Modbus	Modbus	Modbus	None	None	Modbus	Modbus	Modbus	Modbus	Modbus	Modbus
Relays	None	None	YES	None	None	None	None	None	None	None	YES	YES
ZSI	GF&ST	GF&ST	GF&ST	GF&ST	GF&ST&I	GF&ST&I	GF&ST&I	GF&ST&I	GF&ST&I	GF&ST&I	GF&ST&I	GF&ST&I

Step 8. Overcurrent Protection Package

Digit	Package
X	None
1	LI
2	LSI ¹
3	LSIG ¹
4	LSIGA ¹
5	LSIGD ¹
6	LSH
7	LSHG
8	LIG
9	LIGA
A	LIGD
B	LSHGA
C	LSHGD
D	LSIH

Catalog Numbers

Step 9. Trip Unit Rating Plug

- Shaded areas indicate availability
 - **A** indicates availability for all trip units
 - **E** indicates available only for EntelliGuard TU trip units
 - **M** indicates available only for MicroVersaTrip Plus and Enhanced MicroVersaTrip PM trip units

Digit	Current Sensor Rating									
	X	200	400	800	1000	1600	2000	2500	3000	4000
A	100	A								
B	150	A	M							
C	200	A	A							
D	225		A							
E	250		A							
F	300		A	M						
G	350	E	E	E	E	E	E	E	E	E
H	400		A	A	M					
I	450			A						
J	500			A						
K	600			A	A	M				
*	630	E	E	E	E	E	E	E	E	E
M	700			A						
L	750						M			
N	800			A	A	A	M			
O	900	E	E	E	E	E	E	E	E	E
P	1000				A	A	A			
Q	1100					A				
R	1200					A	A		M	
S	1250	E	E	E	E	E	E	E	E	E
T	1500						A			
U	1600					A	A	A	A	A
V	1900	E	E	E	E	E	E	E	E	E
W	2000						A	A	A	A
Y	2200	E	E	E	E	E	E	E	E	E
Z	2400	E	E	E	E	E	E	E	E	E
1	2500							A	A	A
2	3000								A	A
3	3200	E	E	E	E	E	E	E	E	E
4	3600									A
5	4000									A
6	5000									
7	6000									
8	6400									
9	UNIV									
0	None									

Catalog Numbers

Step 10. Shunt Trip

Digit	Voltage
0	None
1	12VDC
2	24VAC/24VDC
3	48VAC/48VDC
4	120VAC/125VDC
5	208VAC
6	240VAC/250VDC
7	480VAC
8	600VAC
H	12VDC
J	24VAC/24VDC
K	48VAC/48VDC
L	120VAC/125VDC
M	208VAC
N	240VAC/250VDC
P	480VAC
R	600VAC

Step 11. Bell Alarm, Bell Alarm with Lockout, Kirk Key Provision

Digit	Bell Alarm	Bell Alarm w/Lock Out ¹	Kirk Key Provision ²
0	None	None	None
1	None	240	None
2	None	600	None
3	None	FUTURE	None
4	240L	None	None
5	240L	240	None
6	240L	600	None
7	FUTURE	FUTURE	None
8	600L	None	None
9	600L	240	None
A	600L	600	None
B	FUTURE	FUTURE	None
C	FUTURE	XXXXX	None
D	FUTURE	XXXXX	None
E	FUTURE	XXXXX	None
F	FUTURE	XXXXX	None
G	None	None	4
H	None	240	4
J	None	600	4
K	XXXXX	XXXXX	4
L	240L	None	4
M	240L	240	4
N	240L	600	4
P	XXXXX	XXXXX	4
R	600L	None	4
S	600L	240	4
T	600L	600	4
U	FUTURE	FUTURE	4
V	FUTURE	XXXXX	4
W	FUTURE	XXXXX	4
X	FUTURE	XXXXX	4
Y	FUTURE	XXXXX	4

¹ Bell Alarm ratings VAC

² Kirk Key Provision number of key locks 1-4

Step 12. Undervoltage Release & Racking Padlock

Digit	Undervoltage Release	Racking Padlock ³
0	None	None
1	24VAC	None
2	48VAC	None
3	120VAC	None
4	208VAC	None
5	240VAC	None
6	480VAC	None
7	600VAC	None
8	24VDC	None
9	24VDC	None
A	48VDC	None
B	125VDC	None
C	250VDC	None
D	XXXXX	XXXXX
E	XXXXX	XXXXX
F	XXXXX	XXXXX
G	None	All
H	24VAC	All
J	48VAC	All
K	120VAC	All
L	208VAC	All
M	240VAC	All
N	480VAC	All
P	600VAC	All
R	12VDC	All
S	24VDC	All
T	48VDC	All
U	125VDC	All
V	250VDC	All
W	XXXXX	XXXXX
X	XXXXX	XXXXX
Y	XXXXX	XXXXX

³ Frame Rating

Catalog Numbers

Step 13. Electric Operator, Push Button Cover, Hidden On

Digit	Electric Operator	Push Button Cover	Hidden On
0	None	None	None
1	120VAC	None	None
2	240VAC	None	None
3	24VDC	None	None
4	48VDC	None	None
5	72VDC	None	None
6	125VDC	None	None
7	XXXXX	None	None
8	None	YES	None
9	120VAC	YES	None
A	240VAC	YES	None
B	24VDC	YES	None
C	48VDC	YES	None
D	72VDC	YES	None
E	125VDC	YES	None
F	XXXXX	YES	None
G	None	None	YES
H	120VAC	None	YES
J	240VAC	None	YES
K	24VDC	None	YES
L	48VDC	None	YES
M	72VDC	None	YES
N	125VDC	None	YES
P	XXXXX	None	YES
R	None	YES	YES
S	120VAC	YES	YES
T	240VAC	YES	YES
U	24VDC	YES	YES
V	48VDC	YES	YES
W	72VDC	YES	YES
X	125VDC	YES	YES
Y	XXXXX	YES	YES

Step 15. Auxiliary Switch, Stationary/Draw-out, Trimplate

Digit	Auxiliary Switch	Stationary / Draw-out	Trimplate
0	None	Stationary	None
1	4-240V	Stationary	None
2	8-240V	Stationary	None
3	12-240V	Stationary	None
4	4-600V	Stationary	None
5	8-600V	Stationary	None
6	FUTURE	Stationary	None
7	FUTURE	Stationary	None
8	None	Stationary	YES
9	4-240V	Stationary	YES
A	8-240V	Stationary	YES
B	12-240V	Stationary	YES
C	4-600V	Stationary	YES
D	8-600V	Stationary	YES
E	FUTURE	Stationary	YES
F	FUTURE	Stationary	YES
G	None	Drawout	YES
H	4-240V	Drawout	None
J	8-240V	Drawout	None
K	12-240V	Drawout	None
L	4-600V	Drawout	None
M	8-600V	Drawout	None
N	FUTURE	Drawout	None
P	FUTURE	Drawout	None
R	None	Drawout	YES
S	4-240V	Drawout	YES
T	8-240V	Drawout	YES
U	12-240V	Drawout	YES
V	4-600V	Drawout	YES
W	8-600V	Drawout	YES
X	FUTURE	Drawout	YES
Y	FUTURE	Drawout	YES

Step 14. Closing Solenoid, Door Interlock, Counter

Digit	Closing Solenoid	Door Interlock	Counter
0	None	None	None
1	120VAC	None	None
2	240VAC	None	None
3	24VDC	None	None
4	48VDC	None	None
5	72VDC	None	None
6	125VDC	None	None
7	XXXXX	None	None
8	None	YES	None
9	120VAC	YES	None
A	240VAC	YES	None
B	24VDC	YES	None
C	48VDC	YES	None
D	72VDC	YES	None
E	125VDC	YES	None
F	XXXXX	YES	None
G	None	None	YES
H	120VAC	None	YES
J	240VAC	None	YES
K	24VDC	None	YES
L	48VDC	None	YES
M	72VDC	None	YES
N	125VDC	None	YES
P	XXXXX	None	YES
R	None	YES	YES
S	120VAC	YES	YES
T	240VAC	YES	YES
U	24VDC	YES	YES
V	48VDC	YES	YES
W	72VDC	YES	YES
X	125VDC	YES	YES
Y	XXXXX	YES	YES

Catalog Numbers

Accessory Catalog Numbers

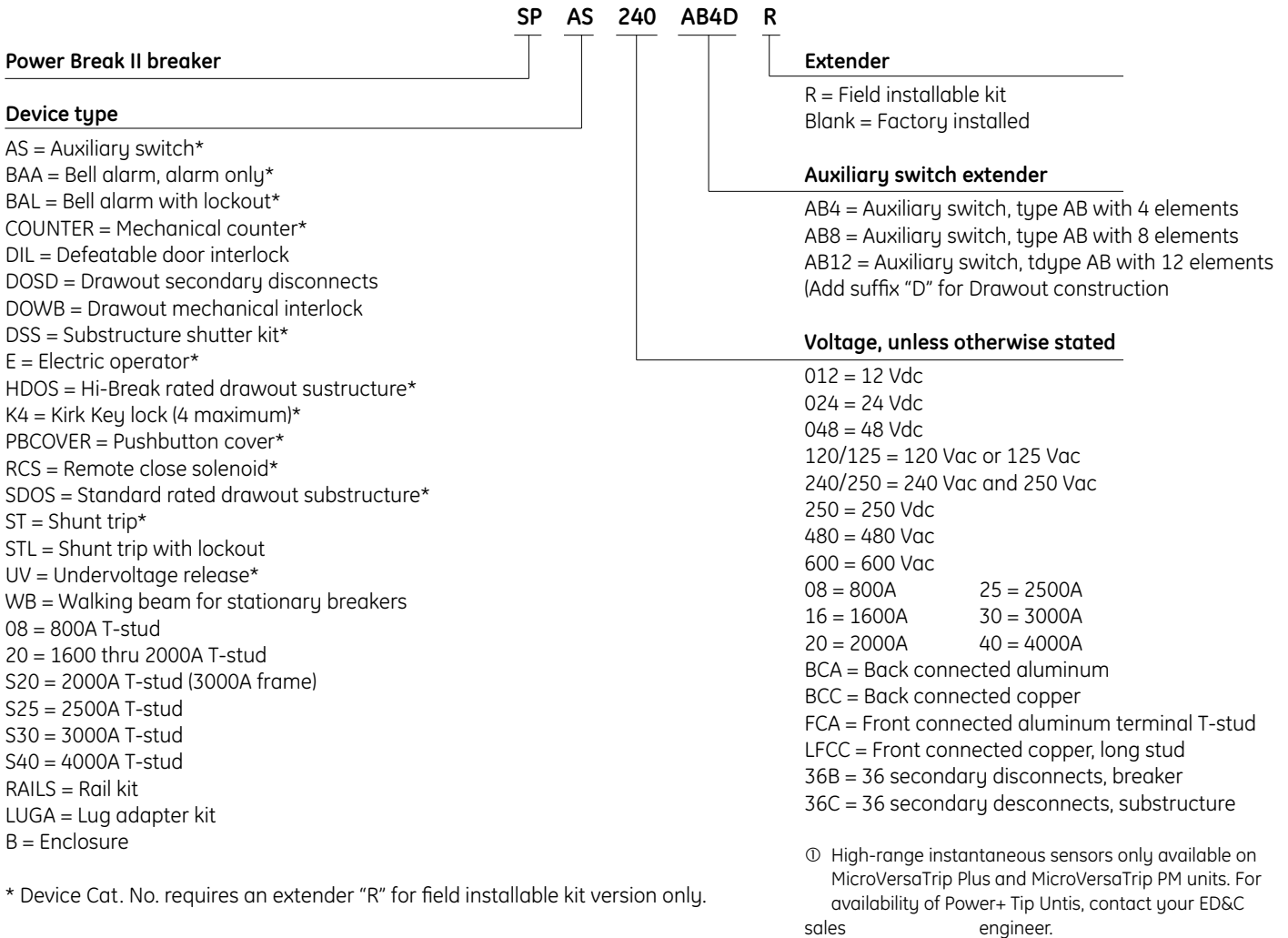

Catalog Numbers

EntelliGuard® TU Catalog Numbers

Digit	G	B	2	0	4	L	5	C	U	X	R	X	X	X	X
Step	1		2	3		4		5	6	7	8				
	Trip Unit Form	Frame Rating	Sensor Rating	OC & GF Rotation Packages		Zone Selective Interlocking		Advanced Features & Communications	Manual / Auto Trip Reset	Original or Replacement	Reserved	Reserved	Reserved	Reserved	

Step 1. EntelliGuard Trip Unit Form

Digits	Trip Unit Form
GA	PB1 (UL)
GB	PB2 (UL)
GC	AKR (ANSI)
GW	WP (ANSI)
GL	Mpact Low (IEC)
GH	Mpact 24-48V (IEC)
GQ	Mpact 120-240V (IEC)
GG	EntelliGuard G ACB (ANSI)
GU	EntelliGuard G ACB (UL)
GS ¹	EntelliGuard G Switch (UL/ANSI)
GT	EntelliGuard G ACB (IEC)
GE	Entellisys Breakers (ANSI)
GF ²	Ground Fault Relay Power Break II (UL)
G1	EntelliGuard Trip Universal Spare
G2	Type A Conversion Kits (ANSI)
G3	EntelliGuard G Switch (IEC)
G4	
G5	
G6	
G7	
VB	EntelliGuard MTU (IEC)

¹ Ground Fault Relay version for EntelliGuard G switches (future)

² Ground Fault Relay version for Power Break II switches (future)

Step 2. Frame Ratings

Digit	Frame Rating (A)	Power Break II
1	800A	•
2	1600A	•
3	2000A	•
4	2500A	•
5	3000A	•
6	3200A	
7	4000A	•
8	5000A	
9	6000A	
A	225A	
B	Sq. Rated (ICW = ICU) 3200-6000A, 100kAIC @ 480/508V	
C	600A	
E	Sq. Rated (ICW = ICU) 400-2000A, 85kAIC @ 480/508V	
H	85kAIC @ 440/480/508V, 65kAIC @ 600/635V, 65kAIC @ 690V	
L	150kAIC @ 440/480/508V, 100kAIC @ 600/635V, 100kAIC @ 690V	
M	100kAIC @ 440/480/508V, 85kAIC @ 600/635V, 85kAIC @ 690V	
N	65kAIC @ 440/480/508/600/635V, 40kAIC @ 690V	
R ¹	260kAIC	
S	50kAIC @ 440/500V IEC, 40kAIC @ 690V IEC	
T ¹	PCTO/F5	
U	Narrow Frame 85kA Icw	
V ¹	AKR Retrofit Breakers	
W	800A AKR30S only	
Y	Narrow Frame 100kA Icw	

¹ Future

Catalog Numbers

Step 3. Sensor Rating (amperes)

Digits	Sensor Rating (A)
00 ¹	UNIV
01	150
02	200
03	225
04	400
06	600
07 ¹	630
08	800
10	1000
12	1200
13 ¹	1250
14	
15	
16	1600
20	2000
25	2500
30	3000
32	3200
40	4000
50	5000
60	6000
64 ¹	6400

¹ EntelliGuard® G IEC designs only

Step 4. OC and GF Protection Packages

Digits	Protection	Power Break I & II
L1		
L2		
L3	LSI (S, switchable) (I, switchable ANSI only) (I is non-switchable for AKR30S conversion kits)	•
L4	LSIG (S, switchable) (I, switchable ANSI only) (I is non-switchable for AKR30S conversion kits)	•
L5	LSIGA (S, switchable) (I, switchable ANSI only)	•
L6	LSIC (S, switchable) (I, switchable ANSI only)	
L7	LSICA (S, switchable) (I, switchable ANSI only)	
L8	LSIGDA* (S, G, A all switchable) (I, switchable ANSI only)	•
L9	LSIGCDA* (S, G, C, A all switchable) (I, switchable ANSI only)	

Step 5. Zone Selective Interlocking

Digit	Zone Selective Interlocking	Power Break II
Z	ZSI, Short time and GF; user selectable	•
T	Z + IOC ZSI; user selectable	• ¹
V		
W		
X	None selected	•

¹ Instantaneous out only

Step 6. Advanced Features & Communications

Digit	Features & Communications	Power Break II
1	RELT	•
2	Modbus Protocol + RELT	•
3	Profibus Protocol + RELT	
4	Monitoring + RELT	•
5	Monitoring + Relay Package + RELT	•
6	Monitoring + Data Acquisition, Modbus Protocol + RELT	•
7	Monitoring + Data Acquisition, Profibus Protocol + RELT	
8	Monitoring + Data Acquisition + Relay Package, Modbus + RELT	
9	Monitoring + Data Acquisition + Relay Package, Profibus + RELT	
X	None Selected	•
A ¹	Modbus Protocol (w/o RELT)	•
B ¹	Monitoring (w/o RELT)	•
C ¹	Monitoring + Relay Package (w/o RELT)	•
D ¹	Monitoring + Data Acquisition, Modbus Protocol (w/o RELT)	•
E ¹	Monitoring + Data Acquisition + Relay Package, Modbus (w/o RELT)	•

"Monitoring" option includes Thermal Sensing for EntelliGuard ACBs only, not for Legacy breakers

¹ Options A - E are only available on Legacy breakers

Step 7 Manual/Auto Trip Reset

Digits	Reset	Power Break II
M ¹	Manual Lockout	
A ¹	Auto Reset/Reclose	
S ²	Auto/Manual Lockout (Selectable)	
X ³	Not Selected	•

¹ Not available for Legacy breaker

² Not available for Legacy and ANSI/UL EG, IEC Only

³ Not available for GACB & Mpact breakers

Step 8 Original or Replacement Trip Unit

Digit	Original or Replacement Trip Unit
R	Replacement trip unit (shipped loose)

Catalog Numbers

EntelliGuard® TU Trip Unit Rating Plug Product Numbers

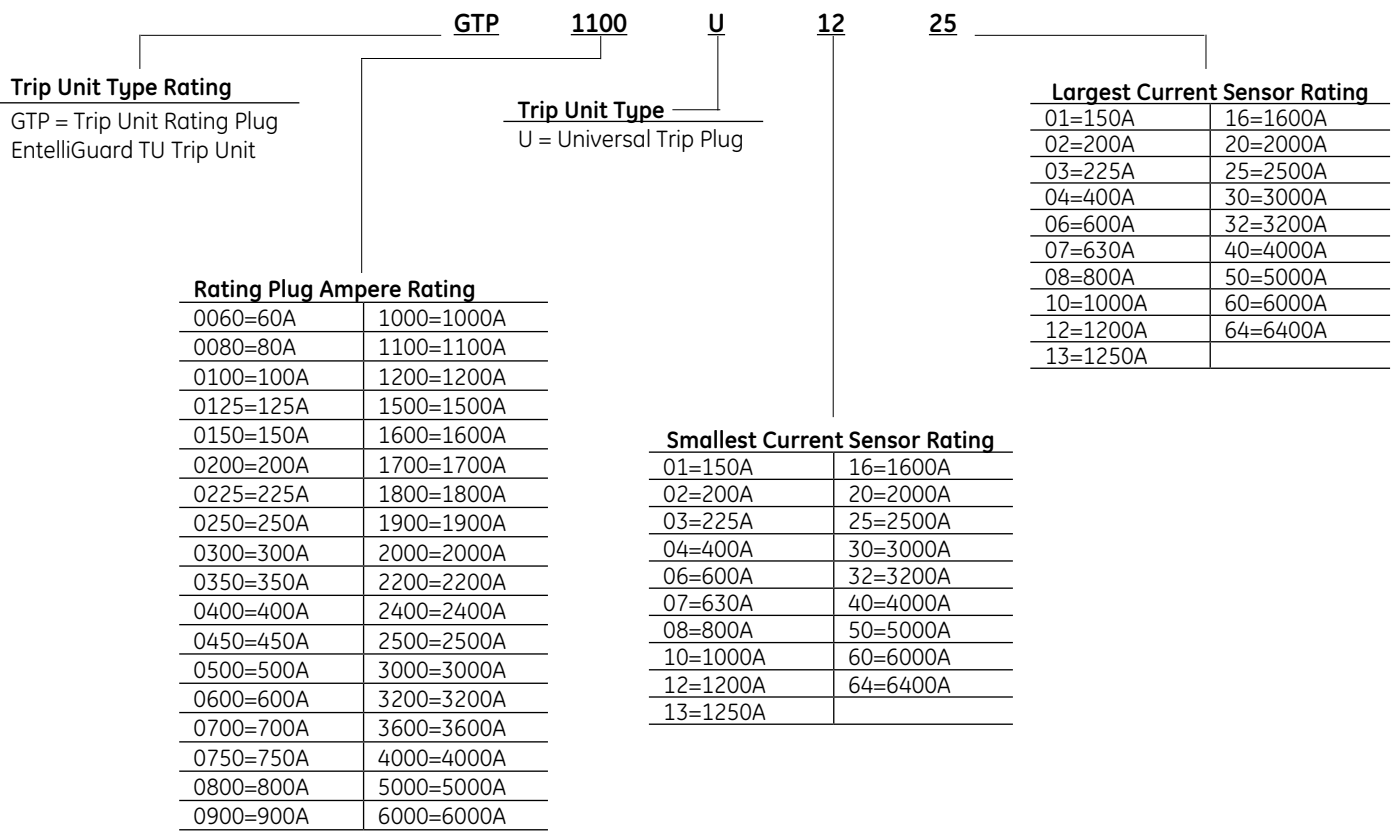

Catalog Numbers

Power+™ Trip Unit Catalog Numbers

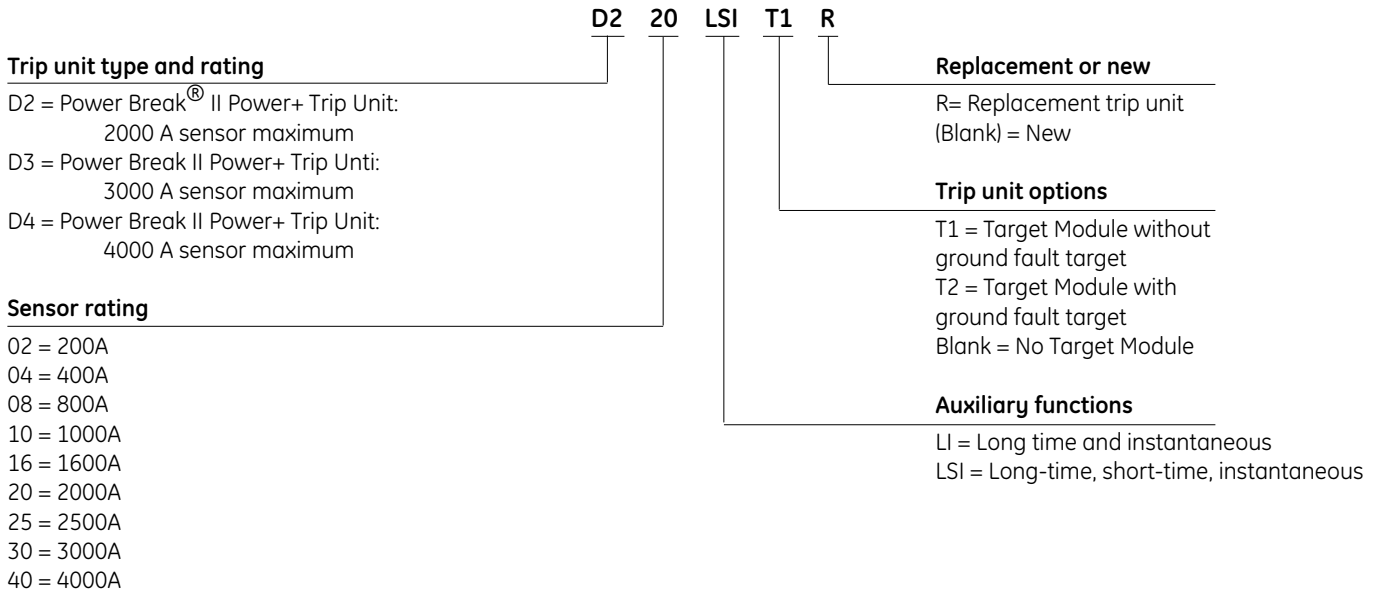

Rating Plug Catalog Numbers

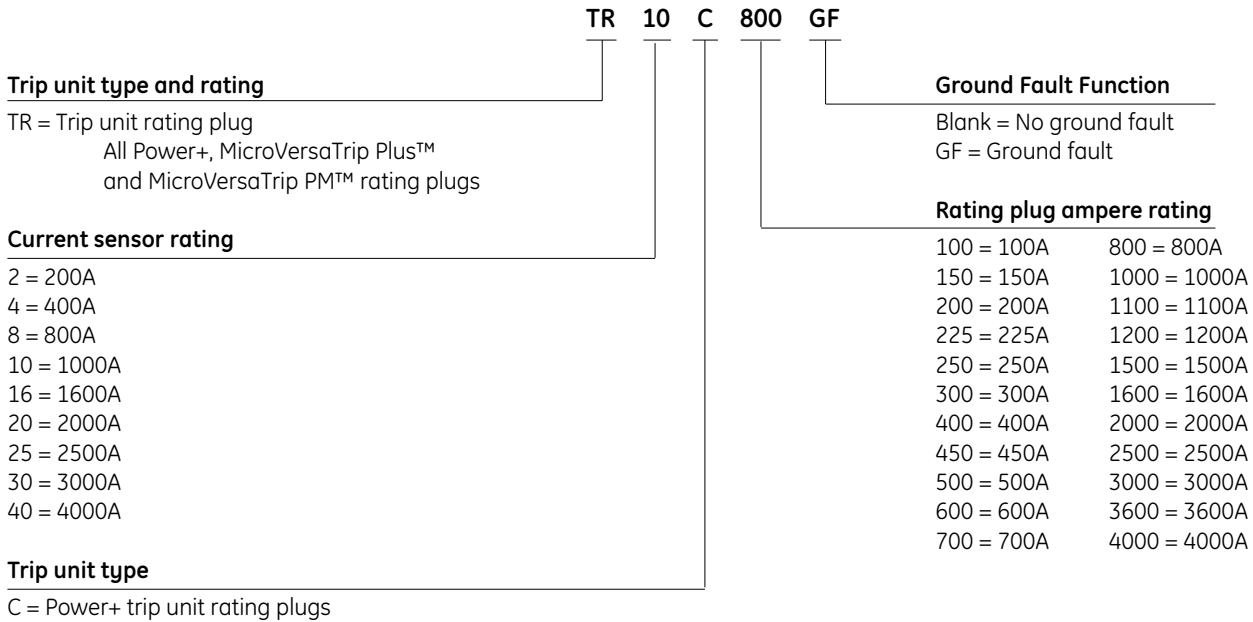

Target Module Catalog Numbers

- TARGET00= Blank insert for Target Module
- TARGET01= Target Module without ground fault target
- TARGET02= Target Module with ground fault target

Catalog Numbers

MicroVersaTrip Plus™ and MicroVersaTrip PM™ Trip Unit Catalog Numbers

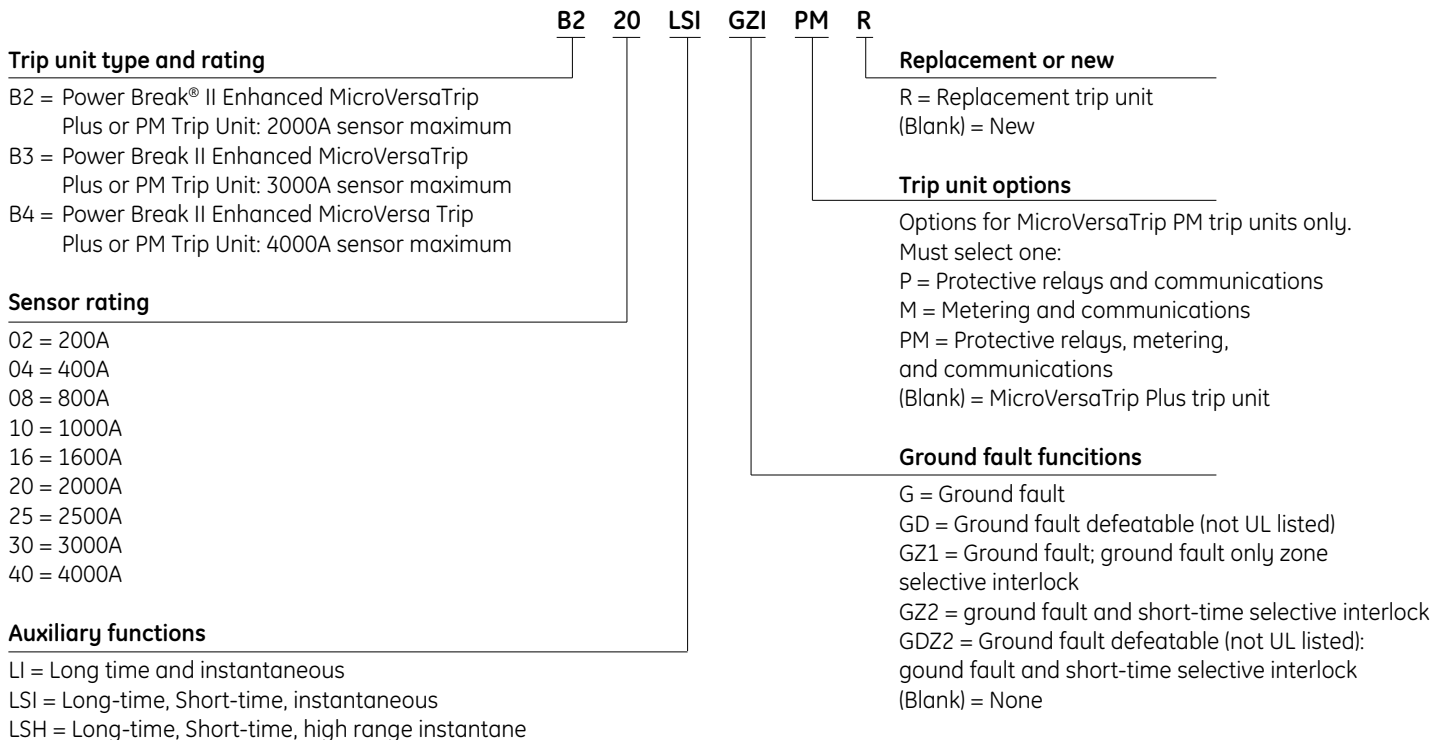

Rating Plug Catalog Numbers

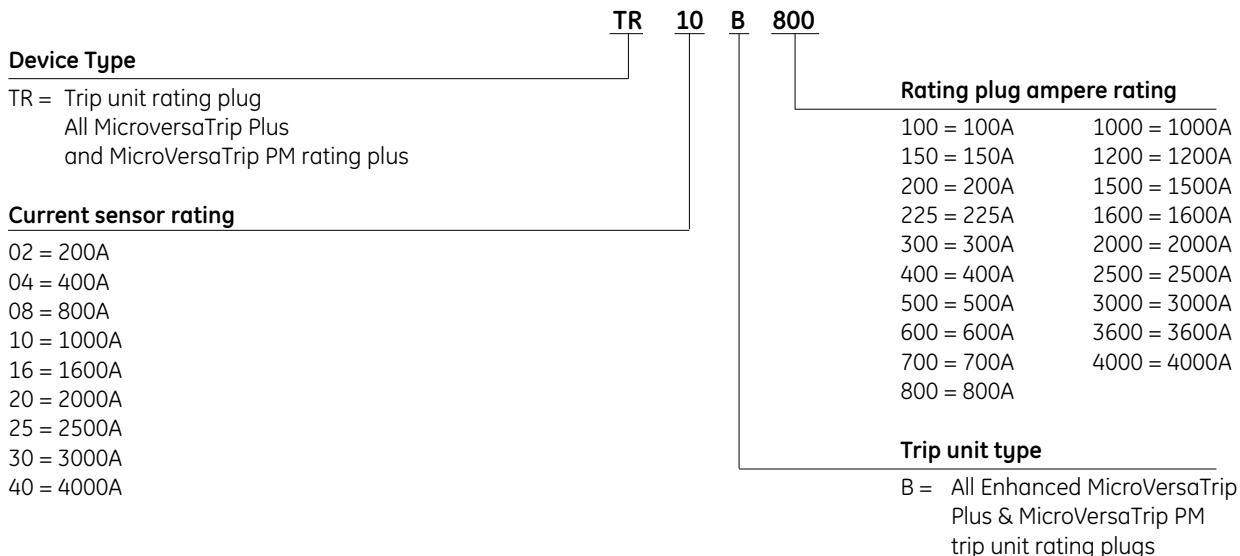

Application

Standards And Testing

Power Break® II circuit breakers are UL Listed in accordance with Standard UL 489. This standard requires the breaker to meet or exceed endurance and interrupting criteria. Power Break II breakers are designed and tested to exceed these requirements.

UL 489 requirements for endurance capability without current (mechanical endurance) vary with frame ratings. For example, for an 800-amp frame, the UL requirement is 3000 operations; and for a 4000-amp frame, only 1100 operations. All Power Break II breakers are designed to exceed this requirement by meeting a minimum of 10,000 mechanical operations.

UL Test Procedures

Extracted from UL Standard 489, current edition.

The following information briefly describes the types of tests Power Break II insulated case circuit breakers, rated 800 through 4000 amperes, must successfully pass.

- 1. Calibration:** Tested at 200%, and 135% at 25° C. At 200%, an 800A breaker must trip in 2 to 30 minutes depending on the current rating. At 135%, all sizes (larger than 50 amperes) must trip within 2 hours.
- 2. Overload:** 50 operations making and breaking six times rated current at rated minimum voltage, 0.45-0.50 power factor for 800 and 1600A frame sizes; 2000 and 2500A frames, 25 operations at six times rated current; and, 3000 and 4000A frames, 3 operations at six times rated current plus 25 operations at two times rated current. Tests are conducted at one operation per minute, (make and break), but may be done in groups of five operations with 15-minute delay between groups.

Overload test is conducted in a metal enclosure representing the minimum size enclosure for which the breaker is suitable. No electrical or mechanical breakdown is permitted and a 30-ampere fuse, connected from the metal enclosure to the line lead least likely to arc to the enclosure, must not rupture.

- 3. Repeat 200% calibration test.**
- 4. Temperature Test:** The circuit breaker after overload is outfitted with 4 ft. minimum of rated copper cable per pole, line and load end, and rated current is passed through the breaker which is not in an enclosure. After temperatures have stabilized, the temperature rise on the cables at the connection to the breaker wiring terminals must not exceed 50° C rise, (75° C total in a 25° C room ambient), and the breaker must not trip. Cables are sized as shown in Table 53.1. When the copper bus bars are used instead of cable for 1600-4000A breakers, they are sized per Table 53.2.
- 5. Endurance:** The breaker must complete an endurance test (1) making and breaking rated current at rated voltage, .75-.80 lagging power factor and (2) additional no

load (mechanical) on-off operations per Table 38.1. The ground-fault fuse described in item 2 above must not rupture.

The rate of operation is one per minute except the 3000 and 4000A electrical test may be in groups of five with a delay in between after conducting the first 10 operations at one per minute.

Table 48.1
Number of Endurance Test Cycles

Frame Size (Amps)	Number of Cycles of Operation		
	With Current	Without Current	Total
800	500	3000	3500
1600	500	2000	2500
2000	500	2000	2500
2500	500	2000	2500
3000	400	1100	1500
4000	400	1100	1500

- 6. Repeat 200% calibration test.**
- 7. Interrupting ability (short-circuit)** for devices rated 600 Vac (all Power Break II breakers): Each pole of the 3-pole unit must complete an "opening" operation (O) and a "close-open" operation (CO) of short-circuit current (single-phase) in Table 48.2 at rated voltage. An "O" and "CO" operation using all three poles ("common" 3-phase tests) is also required on the same device used for previous the tests in items 1-6. Short-circuit test are acceptable if:
 - a) there is no electrical or mechanical breakdown;
 - b) the ground fuse has not opened;
 - c) the conductor insulation is not damaged;
 - d) there is continuity in the closed position at rated voltage; and,
 - e) a cotton pad covering any vent openings in the enclosure has not ignited.

Short-circuit test are conducted with rated cable sizes (or bus for 1600A and larger breakers) using a maximum of four feet on the line side and a maximum of 10 inches on load side for 3-pole tests and four feet on load side for single-pole tests.

Table 48.2
Short-Circuit Levels

Frame Size (Amps)	Power Factor, Lagging	3-Pole Circuit Breaker –Available Short-circuit Current Sym. Amp	
		1-Pole, 1-Phase	3-Pole, 3-Phase
800	.45-.50	8660	10000
1600	.25-.30	14000	20000
2000	.15-.20	14000 [Ⓛ]	25000
2500	.15-.20	20000 [Ⓛ]	30000
3000	.15-.20	25000	35000
4000	.15-.20	30000	45000

[Ⓛ] Circuit power factor may be .25-.30.

Application

8. **Repeat 200% calibration test.**
9. **Dielectric voltage withstand:** The tested breaker must withstand applied voltage of twice rated plus 1000 volts (2200 volts for 600V rated breaker) for one minute between:
 - a) line and load terminals,
 - b) poles of opposite polarity, and
 - c) live parts and the metal enclosure.

Performance – High Available Fault Current

(Hi-Break® Power Break® II) Circuit Breakers – The UL Standard 489 specifies additional, optional requirements for evaluation of breakers on faults higher than the “standard” values shown in item 5.

Test sequence is as follows:

1. **Calibration:** 200% of rated current.
2. **Interrupting capacity:** Short-circuit test are conducted to evaluate (1) maximum IC rating, (2) IC at maximum voltage, and (3) IC at maximum kVA. If one or more tests are covered by another, for example, if maximum kVA occurs at maximum voltage test, they may be omitted. An “O” operation and a “CO” operation is required for each evaluation. Acceptable high available fault current ratings are, in RMS symmetrical kilo amperes: 7.5, 10, 14, 18, 22, 25, 30, 35, 42, 50, 65, 85, 100, 125, 150, 200.
3. **Trip-Out:** Conducted at 250% of rated current. Breakers must trip within same time limits as for 200% calibration.
4. **Dielectric voltage withstand:** Conducted at twice rated (test) voltage.
The preceding is an abbreviated description. Refer to the section Standards and References for specific standards.

GE Testing

GE has developed a qualification test plan for the EntelliGuard® TU, Power+™, MicroVersaTrip Plus™ and MicroVersaTrip PM™ trip units that is in addition to the tests required by Standard UL 489. The objective is to demonstrate performance and reliability under severe operating conditions. Essential components of the internal qualification test are:

GE Trip Unit Testing

1. **Temperature Cycling.** This test verifies that units are not damaged when exposed to many extreme thermal cycles. The test consists of ramping units from -20°C to 70°C a minimum of 10 times each. Units are soaked at each extreme temperature for 1 hour minimum for each cycle.
2. **Storage Temperature.** This test ensures that units will operate properly following exposure to extreme storage temperature for 72 hours. Units are stored in an un-powered state at -55°C and +85° for 72 hours and then subjected to functional testing to verify proper operation.
3. **Voltage Surge.** This test ensures that the circuit breaker is not susceptible to direct and coupled surge voltages on any primary line or any control input or output line. The test is performed per the ANSI C37.90.1 Surge With-

stand Capability specification on all input and output lines connected to the breaker. Both fast transient and oscillatory surges are applied.

4. **RF and EMI.** These tests ensure that the breaker is not susceptible to radiated electromagnetic fields. The test is performed per the ANSI C37.90.2 Radiated Field Immunity specification. The breaker is subjected to a modulated field of 30-50V/m from 20 MHz to 1GHz with the field polarization applied vertically and horizontally.
5. **Walkie-Talkie Immunity.** The breaker is subjected to standard types of industrial walkie-talkies to ensure that it is immune to nuisance trips or improper operation when nearby walkie-talkies are used.
6. **Wiggins Immunity.** Tests are performed to ensure the breaker will not nuisance trip when exposed to a high inductive load (Wiggy) voltage tester across the energized phase lines.
7. **Humidity.** A number of units are exposed to high-humidity environments of 95% relative humidity for a period of one week to simulate severe environmental conditions.
8. **Heat/Humidity Endurance.** LCD display modules are exposed to +80°C, 85% relative humidity for a minimum of 1000 hours to ensure that the LCD seal and polarizers can withstand severe environments for prolonged periods of time.
9. **POWER LEADER™ Systems Tests.** Tests are performed to prove that the trip units can be integrated into existing POWER LEADER networks. A large number of trip units are configured into a large network of various POWER LEADER devices to ensure that they can communicate when subjected to large network conditions. Many types of systems tests are performed including: communication over long distances, multiple simultaneous event testing, communication protocol testing, integration testing with other devices, and bus fault and bus loading testing.
10. **Dust.** Units are subjected to severe atmospheric dust environments per MIL-STD-810E, Method 510.3, Proc. I.
11. **Salt Spray.** Units are subjected to severe salt spray and salt fog environments per ASTM B117.
12. **Electro-Static Discharge.** Units are subjected to Electro-Static Discharge test of up to 8.0kV per IEC 801-2.

GE Breaker Testing

UL Vibration Testing:

GE Power Break II circuit breakers have been investigated in accordance with UL 489 Supplement SB and vibration tested in accordance with Supplement SB, Section SB2. This qualifies them as UL listed Naval circuit breakers intended for use aboard non-combatant and auxiliary naval ships over 19.8 meters (65 feet) in length. Circuit breakers complying with these requirements shall be marked “Naval”.

Application

Test breakers were subjected to a resonance frequency search from 4 to 33 Hz, 2 hr. dwell at resonance, and a 2½ hr. variable frequency test in each of three rectilinear axes. Tests were performed with the circuit breaker “closed” and also “open.” Vibration input during testing is described by the graph below. Resonance G-forces during testing exceeded 3Gs. Circuit breaker contacts were monitored during testing to verify that contacts did not open when the circuit breaker was “closed” and did not close when the circuit breaker was “open”.

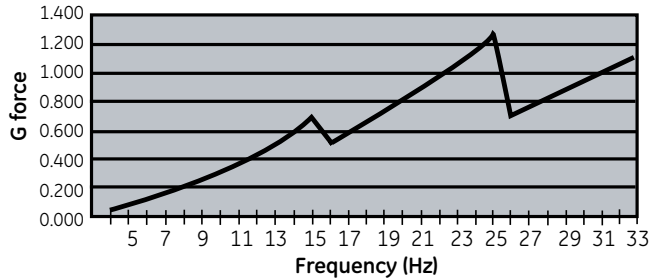

UL489 SB vibration

4G Vibration: In addition, 800-2000A Stationary mounted Power Break® II circuit breakers have been tested to withstand 4G vibration.

Sine Sweep Vibration: Sinusoidal log sweep vibration in each of 3 rectilinear axes with peak acceleration of 4 G from 10 Hz to 500 Hz, followed by 30 minute resonance dwell at the 3 most severe frequencies in each axis.

Random Vibration: Random vibration from 2 Hz to 600 Hz was run to the acceleration density shown below.

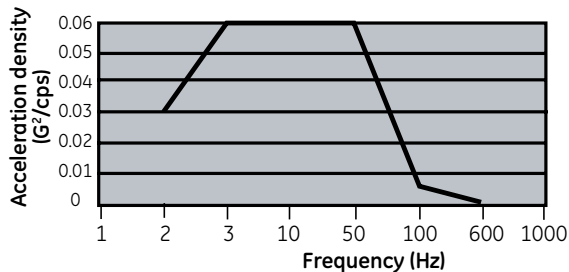

Random vibration test spectrum

IEC Test Qualification

Power Break II circuit breakers are tested to conform with IEC Standard 947-2 for general purpose use with no specific enclosure. Power Break II circuit breakers are designed for intentional time delay under short-circuit conditions as described by IEC 947-2 use category B. In addition, Power Break II circuit breakers are suitable for use in phase-earthed systems and are tested in individual pole short circuits. All Power Break II testing is performed in open air. During short-circuit and endurance under load testing the circuit breakers are surrounded by a perforated metal screen. The screen is positioned over the top of the breaker and located 4.5 inches above the arc chamber vents. The screen also covers a surface located one inch away from the bottom and sides.

The metallic screen is made of 16-gauge steel with 3/16" diameter holes punched on a ¼" stagger creating a 50% metal-to-air ratio. During these tests, a 50 amp OPTS fuse is used to connect the screen to the test supply neutral. Power Break II circuit breakers are short-circuit tested in both the line top and line bottom configuration making them suitable for “reverse feed” applications. The conformance to IEC 947-2 consists of the following test sequences all of which have been third-party witnessed by UL:

I. General Performance Characteristics

1. Tripping Limits and Characteristics:

Power Break II circuit breaker tripping characteristics are verified under short-circuit and overload conditions to meet the relevant trip time curves. Various trip and no-trip conditions are verified.

2. Dielectric Properties:

Power Break II circuit breakers are dielectric tested through the main circuit and the control circuits to withstand 2500 volts for 1 minute without breaking down.

3. Mechanical Operation and Operational Performance Capability:

Power Break II circuit breakers are endurance tested to 10,000 operations without maintenance. 500 operations are performed under full load at rated voltage and the remainder are performed under no-load conditions with a minimum of 10 operations per hour. At least 10% of the no-load operations are opened by a shunt trip or undervoltage device. During the endurance testing the circuit breaker is monitored to ensure the allowable thermal rise limits are not exceeded. In addition to circuit breaker endurance, drawout breakers are racked in and out of their substructure 100 times.

4. Verification of Dielectric Withstand:

Following the endurance test, the circuit breaker's main circuit is verified to withstand a voltage equal to twice its rated insulation voltage for 1 minute.

5. Verification of Temperature Rise:

Following the dielectric verification, a temperature-rise test is made at the rated current at any convenient voltage. The breaker is connected in open air to a power supply through copper bus. Each main terminal is fed by 3 each 3" x 0.25" x 3 meter long copper bus sections hung vertically, painted flat black and spaced 0.25" apart. The main terminals are verified to not rise more than 80°C above ambient. The operating handle and push-to-close button are verified to rise no more than 35 and 50°C respectively. Other areas are also verified.

Application

II. Rated Service Short-Circuit Breaking Capacity (Ics)

- 1. Rated Service Short-Circuit Breaking Capacity:**

Power Break® II circuit breakers are tested to complete a series of short-circuit interruptions with a 3-minute rest period between interruptions. The breakers must complete an “open” operations followed by a “close-open” operation and another “close-open” operation. The circuit breakers are tested with an open circuit voltage sufficient to enable a recovery voltage of the rated voltage plus 5%. The 800-2000 amp Power Break II circuit breakers are tested in a 56,000 amps rms symmetrical, 50 Hz, 20% power factor short circuit. (See Table 56.1)
- 2. Verification of Dielectric Withstand:**

Following the short-circuit interruptions, the breaker’s main circuit is verified to withstand a voltage equal to twice its rated insulation voltage for 1 minute.
- 3. Verification of Temperature Rise:**

Following the dielectric verification, a temperature-rise test is made at the rated current and the main terminals are monitored as previously described in Sequence I test 5.
- 4. Verification of Overload Release:**

Following the temperature-rise verification, the circuit breaker overload protection is verified by applying 145% of rated current through all three poles connected in series. The breaker must trip within trip time curve.

III. Rated Ultimate Short-Circuit Breaking Capacity (Icu)

- 1. Verification of Overload Release:**

Prior to short-circuit testing, the circuit breaker overload protection is verified by applying 200% of rated current through each pole individually. The breaker must trip within the trip time curve.
- 2. Rated Ultimate Short-Circuit Breaking Capacity:**

Power Break II circuit breakers are tested to complete a series of short-circuit interruptions with a 3 minute rest period between interruptions. The breakers must complete an “open” operation followed by a “close-open” operation. The circuit breakers are tested with an open circuit voltage sufficient to enable a recovery voltage of the rated voltage plus 5%. The 800 – 2000 amp Power Break II circuit breakers are tested in a 75,000 amp rms symmetrical 50 Hz, 20% power factor short circuit.
- 3. Verification of Dielectric Withstand:**

Following the short-circuit interruptions, the breaker’s main circuit is verified to withstand a voltage equal to twice its rated insulation voltage; however, not less than 1000V for 1 minute.
- 4. Verification of Overload Release:**

Following the dielectric verification, the circuit breaker overload protection is verified by applying 250% of rated current through each pole individually. The breaker must

trip within the trip time curve.

IV. Rated Short-Time Withstand Current (Icw)

- 1. Verification of Overload Release:**

Prior to short-circuit testing, the circuit breaker overload protection is verified by applying 200% of rated current through each pole individually. The breaker must trip within the trip time curve.
- 2. Rated Short-Time Withstand Current:**

Power Break II Circuit breakers are tested to carry a short-time withstand current with the overcurrent and instantaneous over-ride protection defeated. For the 800-2000 amp Power Break II circuit breakers, a short circuit is calibrated to deliver the equivalent I²T of a 40,000 amp rms symmetrical short circuit for 1 second or 1,600,000,000 I²T. Also, the test circuit is calibrated to reach a peak current of at least 84,000 amps during its first half cycle. Since momentary contact separation can occur during this test, the test is made at rated voltage. The test is performed at a frequency of 50 Hz with a plus or minus 25% tolerance and a 25% power factor.
- 3. Verification of Temperature Rise:**

Following the short-time withstand, a temperature-rise test is made at the rated current and the main terminals are monitored as previously described in Sequence I test 5.
- 4. Short-Circuit Breaking Capacity at the Maximum Short-Time Withstand Current:**

Following the temperature verification the breakers are tested to complete a series of short-circuit interruptions with a 3-minute rest period between interruptions. The breakers must complete an “open” operation followed by a “close-open” operation. The circuit breakers are tested with an open circuit voltage sufficient to enable a recovery voltage of the rated voltage plus 5%. The 800-2000 amp Power Break II circuit breaker is tested in a 40,000 amp rms symmetrical, 50 Hz, 25 % short circuit.
- 5. Verification of Dielectric Withstand:**

Following the short-circuit interruptions, the breaker’s main circuit is verified to withstand a voltage equal to twice its rated insulation voltage for 1 minute.
- 6. Verification of Overload Release:**

Following the dielectric verification, the circuit breaker overload protection is verified by applying 250% of rated current through each pole individually. The breaker must trip within the trip time curve.

Application

V. Individual Pole Short-Circuit Test Sequence (Isu)

1. Individual Pole Short-Circuit Breaking Capacity:

Power Break® II Circuit breakers are tested to complete a series of short-circuit interruptions with a 3-minute rest period between interruptions. The breakers must complete an “open” operation followed by a “close-open” operation on each pole individually. The circuit breakers are tested with an open circuit voltage sufficient to enable a recovery voltage of the rated voltage plus 5%. The 800-2000 amp Power Break II circuit breakers are tested using two phases of a three-phase 25,000 amp rms symmetrical, 50 Hz, 25% power factor short circuit.

2. Verification of Dielectric Withstand:

Following the short-circuit interruptions, the breakers main circuit is verified to withstand a voltage equal to twice its rated insulation voltage; however, not less than 1000 V for 1 minute.

3. Verification of Overload Release:

Following the dielectric verification, the circuit breaker overload protection is verified by applying 250% of rated current through each pole individually. The breaker must trip within the trip time curve.

Table 52.1

Test Tolerance: Unless Otherwise Specified

	All Tests	No Load, Normal Load or Over Load	Short Circuit
Current	+5%-0%	—	3500
Voltage	+5%-0%	—	2500
Frequency	—	±5%(47.5-52.5 Hz)	±5%(47.5-52.5 Hz)
Power Factor	—	±0.05	+0 -0.05

Power Break® II – 100 % Rated Circuit Breakers

Power Breaker II circuit breakers are UL Listed to carry 100% of rating-plug nameplate current, continuously^①, when installed in accordance with guideline printed on the breaker, and as detailed in the following Current Rating Factors portion of this section.

Standard Rated Devices

A “Standard rated” device is rated to carry 100% of its nameplate current for short periods of time (up to 3 hours maximum) when enclosed in equipment, such as a switchboard. The enclosed device has a continuous rating of 80% of rating according to current versions of the National Electric Code (Article 220-10).

100% Rated Devices

100% rated devices are designed to carry 100% of their nameplate current rating when enclosed and tested in distribution equipment.

Breakers with 100% rating are so marked on the front of the devices. This marking includes minimum enclosure size, minimum ventilation (if any), minimum cable sizes and temperature ratings to be used. Current versions of the National Electric Code permit such use in the exceptions to Articles 210-22(c) and 220-10 (b).

Factors Affecting the Current Ratings of Installed Devices

There are six application factors to consider in selecting current rating on installed Power Break II insulated case circuit breakers. These are: 1) the size of the cable or bus used in the line and load connections, 2) the actual installed ambient temperature, 3) the system operating frequency, 4) the altitude of the installation, 5) the type of loading of the protected circuit, and 6) the design safety factor.

The following simple relationship combines these six application factors into a single equation:

$$I_{CB} = I_A \times A \times B \times C \times D \times E \times F$$

I_{CB} = Installed circuit breaker current rating, amps

I_A = Actual load current, amps

A = Cable or bus sizing factor

B = Ambient temperature rating factor

C = Frequency rating factor

D = Altitude rating factor

E = Load class rating factor

F = Safety factor

Cable or Bus Size

The thermal design of a circuit breaker takes into account the ability of the line and load cables or buses to act as heat sinks. Standard UL 489 has assigned specific cable or bus sizes for each current rating. Generally, these assignments are coordinated with specific conductor temperature ratings. Increasing a conductor’s temperature rating decreases both the cross-sectional area and its ability to conduct heat from the circuit breaker. The chart below illustrates the effect of changing cable areas on the current-carrying ability of the circuit breaker.

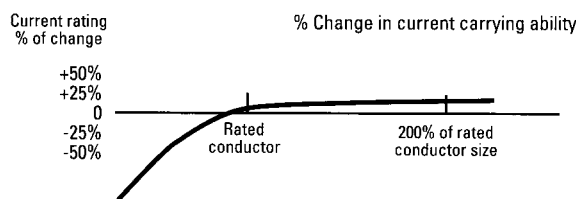

Effects of changing load and line conductor sizes

① 4000 A stationary 80 %

Application

Table 53.1
Required Cable Size

Frame Rating (Amps)	Sensor Rating or Rating Plug Rating (Amps)	Cable Size and Quantity				Cable Min Temp. Rating Carrying 100% Continuously (°C)
		Copper Cables		Aluminum Cables		
		Qty.	Size (mcm)	Qty.	Size (mcm)	
800	200	1	3/0	1	250	75
	400	1	600	2	250	75
	600	2	350	2	500	75
	800	2 or 3	600 or 300	3	400	75
1600	800	3	300	3	400	75
	1000	3	400	4	350	75
	1200	4	350	4	500	75
	1600	5	400	5	600	90 ^①
2000	2000	6	400	6	600	90 ^①
2500	2000	6	400	6	600	75
	2500	7	500	8	600	90 ^①
3000	3000	8 or 9	400 or 500	9 or 10	500 or 600	90 ^①
4000	4000	10 or 11	500 or 600	12 or 13	500 or 600	90 ^①

① 100% Continuous load requires use of 90°C cable sized to 75°C ampacity. Lugs must be marked CU9AL or AL9CU or AL9 denoting suitability with 90°C cable.

Table 53.2
Required Bus Size – Bare Or Tinned Copper

Frame Rating (Amps)	Bus Bars Per Terminal	
	Number	Size in (Inches)
1600	2	¼ X 3
2000	2	¼ X 4
2500	2	¼ X 5
	4	¼ X 2 ½
3000	4	¼ X 4
4000	4	¼ X 5

Table 53.3
Properties Of Conductors

Size AWG/ KCMIL	Area Cir. Mills	Conc. Lay Or Stranded No. Wires	Conc. Lay or Stranded Diameter/ Wire (in.)	Bare Conductors Diameter	Area Square Inches	DC Resistance* Bare Copper	DC Resistance* Tinned Copper	DC Resistance* Aluminum	Equiv. Cross Sect. Area AWG/ KCMIL	ISO Metric Cable Size (mm) ²
3/0	167,800	19	0.0940	0.470	0.173	0.0642	0.0668	0.105	85	95
250	250,000	37	0.0822	0.575	0.260	0.0431	0.0449	0.0708	127	120
300	300,000	37	0.0900	0.630	0.312	0.0308	0.0374	0.0590	152	150
350	350,000	37	0.0973	0.681	0.364	0.0320	0.0333	0.0505	177	185
400	400,000	37	0.1040	0.728	0.416	0.0270	0.0278	0.0442	202	—
500	500,000	37	0.1162	0.813	0.519	0.0216	0.0222	0.0354	253	240
600	600,000	61	0.0992	0.893	0.626	0.0180	0.0187	0.0295	304	300
750	750,000	61	0.1109	0.998	0.782	0.0144	0.0148	0.0236	380	—

* Note: DC resistance values are shown in ohms per 1000 feet at 25°C (77°F).

Application

Table 54.1
Factor "A" – Cable Or Bus Size Multiplying Factor

Percentage of Rated (Required) Cross-Sectional Area (%)	Factor A
50	1.40
60	1.25
70	1.15
80	1.07
90	1.02
100	1.00
125	0.99
150	0.97
200	0.97

Ambient Temperature

Ambient temperatures have an even wider effect on the rating of the breaker-cable system. While the internal sensing and tripping circuitry with the EntelliGuard® TU, Power+™, MicroVersa-Trip Plus™ and MicroVersaTrip PM™ trip units are ambient insensitive, high-ambient temperatures may cause internal components to exceed their operating temperature limits. Low temperatures substantially increase the current-carrying capabilities of the breaker-cable system until other limiting factors occur (e.g., lubrication problems or mechanical binding of internal parts due to differential contraction). The ambient temperature of a Power Break® II breaker should not be less than -20°C nor exceed +70°C.

Cable with insulation ratings above 75°C may be used, providing it is sized to 75°C, per the NEC, or other applicable codes.

The term "ambient" temperature always refers to the temperature of the air immediately surrounding the breaker and not the temperature of the air outside the breaker's enclosure. Room or outside air temperatures only establish the thermal floor to which all other heating is added.

To convert breaker ambient from room ambient, it is necessary to know the temperature rise within the equipment housing the breaker. The temperature rise is a function of several variables, including heating caused by other equipment, ventilation, solar heating, factors relating to group mounting and the free surface area of the breaker's enclosure.

Once the device's ambient temperature is determined, select Factor B from the table.

Table 54.2
Factor "B" – Ambient Temperature Rating Factor

Ambient Temperature °C ¹	Maximum Wire Insulating Rating °C ²	Factor B
25	75	1.00
40	90	1.00
50	105	1.00
60	125	1.10
70	125	1.15

Notes: 1) Average air temperature over a 24-hour period outside the breaker's insulated case, but inside the enclosure. 2) Cable (wire) must be based on 75°C ampacities per Table 310-16, current National Electrical Code.

Operating Frequency

All Power Break II circuit breakers may be applied at their published ratings on 50 Hz and 60 Hz power systems. At nominal system frequencies less than 50 Hz but above direct current, digital solid-state trip devices become inoperative due to sensor saturation. On direct current systems, digital solid-state trip units are completely inoperative. Power Break II circuit breakers are, therefore, not suitable for direct current applications.

System operating frequencies above 60 Hz may change the performance and ratings of circuit breakers by heating metallic parts and significantly reducing interrupting capacity.

Factor "C" – Operating Frequency

For operating frequencies of both 50 Hz and 60 Hz, the operating frequency rating factor "C" = 1.00. For operating frequencies other than 50 Hz and 60 Hz, derating factors "C" are listed below.

Table 54.3
Factor "C" - Frequency Rating

Frequency *	Factor C
dc	—
50-60 Hz	1.00
150-180Hz	1.07
200-240 Hz	1.25
300-350 Hz	1.40
400-450 Hz	1.51

* Power+ trip units and the energy management functions in MicroVersaTrip PM trip units are suitable for 50/60 Hz applications only.

Application

Altitude

Power Break® II circuit breakers are designed for operation at altitudes from sea level to 6000 ft. (1800 meters). Reduced air densities at altitudes above 6000 ft. affects the ability of the circuit breaker to both transfer heat and interrupt short circuits.

Determine the altitude of the breaker’s installation, and select the altitude rating factor “D” from the following table.

Table 55.1
Factor “D” Altitude

Altitude (Feet)	Altitude (Meters)	Factor D
From 100 To 6,000	From 30 To 1,800	1.00
From 6,001 To 10,000	From 1,801 To 3,000	1.04
Above 10,001	Above 3,001	1.08

Load Class Rating Factor

The type of load and its duty cycle must be considered in the application of Power Break II circuit breakers. Loads, such as capacitors and electromagnets, require a substantial and continuous derating factor if the breaker is normally used to switch the load. With loads such as resistance welders, the breaker’s continuous current rating must be no less than 125% of the welder’s 100% duty-cycle rating.

In general, insulated case circuit breakers are intended for the protection of insulated cable. Where a circuit breaker is intended to protect load equipment, prudent engineering practices call for obtaining factory review and concurrence with the selection of a specific protective device. Load class selection factors “E” for typical application are listed in the following table.

Table 55.2
Factor “E” – Load Class or Type

Load Type	Factor E
Switching Electromagnets	1.50
Single Motor Branch Circuit Protection (Normal Duty) ①	1.50
Switching Capacitors	1.50
Single Motor Branch Circuit Protection (Heavy Duty) ①	1.75
All other load Types (Normal Duty)	1.0

① Use this factor to either plugging duty or starting more than 25 times per hour, where the rms current cannot be easily calculated.

Safety Factor

A safety factor is used to provide a design margin between the rating of a circuit breaker and the derived operating current using all of the selection factors described in the equation on page 52. A safety factor of 10% is often used to prevent nuisance tripping.

Factor “F” – Safety Factor

A safety factor of 10% is equivalent to a Factor F of 1.10.

Interrupting Ratings

In addition to current rating considerations, Power Break II circuit breakers must be able to automatically trip, or open, the protected circuits under overload conditions. The breaker must have sufficient interrupting capacity to interrupt the maximum short-circuit that can flow under worst-case conditions.

The following paragraphs describe the interrupting rating of Power Break II circuit breakers.

Basis of Interrupting Ratings

Short-circuit current interrupting ratings depend on knowing the magnitude of short-circuit current that may flow through the circuit breaker. Devices rated in accordance with Standard UL 489 list their interrupting rating in terms of “rms symmetrical amperes.”

Power factor or X/R ratio. Interrupting ratings are based on a specific ratio of resistance – to reactance, or power factor in the faulted circuit. Practical ac circuits contain some reactance, so there is some displacement between current and voltage wave-forms. Since a short circuit can occur at any point of the voltage wave, the actual trace of short-circuit current may display considerable initial displacement from the zero current axis.

The magnitude of the momentary peak current to be interrupted is a function of the maximum peak current displacement from the zero current axis. That displacement is a function of the X/R (ratio of reactance to resistance) or power factor of the faulted circuit. The higher the X/R rating, the lower the power factor and the greater the magnitude of peak current displacement.

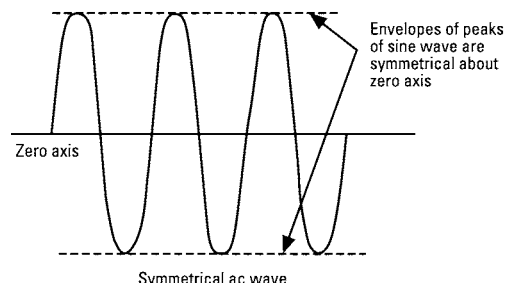

Symmetrical ac waveform

Application

Generally, electrical power system engineers calculate the X/R ratios of circuit rather than power factor. The procedures for calculating short-circuit current and X/R ratios are described in Publication GET-3550.

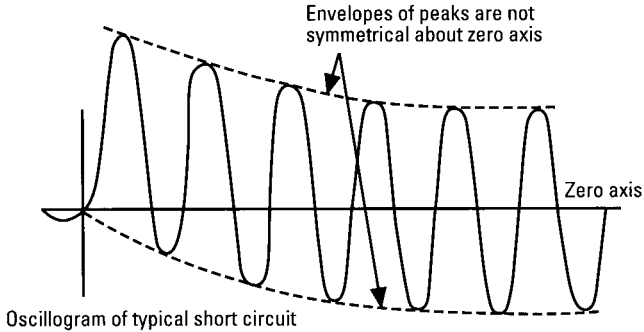

Asymmetrical ac waveform

The figures below show the initial fault current displacement of a pure circuit (symmetrical) and a reactive circuit with a high X/R ratio. The actual current displacement of a reactive circuit depends on the exact moment the short circuit is applied. There is a simple relationship between power factor and X/R of a faulted circuit:

$$PF = \frac{R}{Z} \times 100 \quad \text{And: } Z = \sqrt{(R)^2 + (X)^2}$$

$$\text{Therefore } PF = \frac{R}{\sqrt{(R)^2 + (X)^2}} \times 100$$

PF = Power factor, % Z = Impedance in ohms
R = Resistance in ohms X = Reactance in ohms

Interrupting Ratings – Standard And Hi-Break® Breakers

Power Break® II breakers are available in two classifications of interrupting ratings: Standard and Hi-Break breakers. All ratings are without the need for external fuses or current limiters. Hi-Break breakers' interrupting ratings are for those circuits with unusually high levels of available fault current.

Table 56.1
Interrupting Rating Breaker Performance In RMS Symmetrical kA

UL 489 50/60 Hz	Frame Size			
	800A	1600 - 2000A	2500 - 3000	4000A
Standard				
240V	65	85	100	100
480V	65	65	100	100
600V	50	50	85	85
Hi-Break®				
240V	100	125	200	200
480V	100	100	150	150
600V	65	65	100	100
Short Time (0.5 sec.)	25	40	42	42
IEC 947 -2 Ratings 415V, 50/60 Hz				
Icu	-	75	75 ^①	85
Ics	-	56	45 ^①	25
Icw (1 sec)	-	40	50 ^①	50

① Requires 4000A construction

Table 56.2
Estimated 400 Hz Interrupting Ratings
RMS Symmetrical Amperes – Not UL Listed

Standard Break				
Frame Size (Amps)	Max. Rating Plug Ampacity ^②	120/240	277/480	346/600
800	600	6500	5000	4200
1600	1000	8500	6500	5000
2000	1200	8500	6500	5000
2500	1600	10000	10000	8500
Hi-Break				
Frame Size (Amps)	Max. Rating Plug Ampacity ^②	120/140	277/480	346/600
800	600	10000	10000	6500
1600	1000	12500	10000	6500
2000	1200	12500	10000	6500
2500	1600	20000	15000	10000

② No additional thermal derating is required for above-maximum rating plug ratings for frame sizes noted. Note: 400Hz interrupting ratings are based on engineering judgment, taking into consideration the operating characteristics of insulated case circuit breakers and the worldwide lack of test facilities to verify performance. Power+™ trip units and the energy management functions in IntelliGuard® TU and MicroVersaTrip PM™ trip units are suitable for 50/60 Hz applications only.

Application

Table 57.1
Interrupting Rating Multipliers-
For High X/R Ratios (Low Power Factors)

When the X/R ratio of a faulted circuit is higher than 4.899 (power factor of 0.20) the breaker's interrupting rating must be derated. The multiplying factor is shown in the table below.

Power Factor	X/R Ratio	Interrupting Capacity Derating Factor
0.20	4.899	1.000
0.19	5.167	0.98
0.18	5.465	0.97
0.17	5.797	0.96
0.16	6.169	0.95
0.15	6.169	0.94
0.14	7.072	0.93
0.13	7.627	0.91
0.12	8.273	0.90
0.11	9.036	0.89
0.10	9.950	0.88
0.09	11.066	0.87
0.08	12.460	0.85
0.07	14.251	0.84
0.06	16.637	0.83
0.05	19.974	0.82
0.04	24.980	0.81

Example Data

A Power Break® II stationary feeder breaker consisting of 770A of continuous loads @ 480Vac required. Available short-circuit current at the breaker is 63kA rms symmetrical with a power factor of 0.13 (X/R ratio of 7.627). Average temperature of the room air could be as high as 45° C (air surrounding the enclosed breaker will be 15° C higher.) Altitude above sea level at the installation site is 6500 feet. The loads are considered critical.

Selection

Since the Power Break II breakers are labeled as suitable to carry 100% of their ampere rating continuously,* there is no need to multiply the continuous load by 1.25 as would be required when using a non 100% rated breaker.

Per UL 489, Power Break II breakers are short-circuit tested with a power factor of 20% (X/R ratio of 4.889); the actual faulted circuit power factor in this example, however, is 13% (X/R ratio of 7.627) and this requires derating of the breaker's interrupting rating per Table 47.1. Multiplying the standard break IC rating of 65kA by .91 gives 59.1kA rating when the power factor is 13% and not 20% minimum.

The available short-circuit current is 63kA and thus the standard break breaker is not adequate and could not be used. The Hi-Break® units are rated 100kA and are acceptable.

Further derating must be done for high ambient conditions. Per Table 54.2 Factor "B", 60°C breaker ambient temperature requires a derating factor of 1.10. Similarly, the 6500-ft. altitude requires a 1.04 derating factor- see Table 55.1 Factor "D".

This feeder is a critical circuit and therefore a Safety Factor F of 1.10 will be applied.

Next multiply the load, IA, by the several factors Ax BxCxDx-ExF to determine the minimum frame ampere rating:

$$I_{CB} = I_A \times A \times B \times C \times D \times E \times F = 770A \times 1.00 \times 1.1 \times 1.00 \times 1.04 \times 1.00 \times 1.1 = 770 A \times 1.258 \text{ or } 969A.$$

Select a 1600A Hi-Break frame with either a 1000A or a 1600A sensor rating with an 800A rating plug because the rating plug is not affected by any of the load characteristics. An 800A rating plug, however, may not permit the 10% safety factor for additional current-carrying capacity above the actual 770A. An alternate choice would be to select a 1000A rating plug and set the current setting (long time pick up) to 0.9 and cable or bus for 900A ampacity. If the alternate choice is used, some local inspecting authorities may require sealing of the sealable trip unit and accessory door to prevent upward adjustment of the 0.90 current setting.

Finally, if insulated conductors are to be used, the high -ambient temperature (60°C) will require using 125°C minimum insulation rating with the conductors sized per the 75°C ampacity tables.

Conductors may be sized to the 800A rating plug value, if used, or to 900A current setting value if a 1000A rating plug is used. Additional derating of the conductors may be required for (1) more than three conductors in a raceway and (2) ambient temperatures other than 30°C. Refer to the National Electrical Code, Article 310.

Breaker Selection

User may select a front connected stationary, Hi-Break breaker, 1600-amp frame, standard instantaneous with 1000-amp current sensor. Rating plug is 1000 amps. An enhanced MicroVersaTrip Plus™ trip unit with LT, ST, and I.

- **Breaker:** Cat. No. SHF16B210
- **Rating Plug:** Cat. No. TR10B1000
- **Trip Unit:** Cat. No. B210LSI

*4000A Stationary 80% rated.

Application

Humidity and Fungus

All ferrous parts are zinc plated with either a yellow dichromate or phosphate finish. Zinc plating resists 96-hour salt spray test. Alloy steel components made of inherently corrosion-resistant materials are not plated.

Current-carrying parts are either silver or tin plated for corrosion protection and to assure reliable electrical joints.

Molded cases and covers, and all internal insulators, are made from inorganic materials that are inherently fungus proof.

Wiring Diagram, Secondary Terminals

All Power Break® II breakers use the same dedicated secondary terminals regardless of frame, rating, accessory or trip unit combinations. The left side set of secondary terminals are assigned to auxiliary switches. The right side set is assigned to all other accessories and breaker functions. Terminals are suitable for (2) #18 -#12 solid or stranded copper wire. Tightening torque is 9 lb-ins.

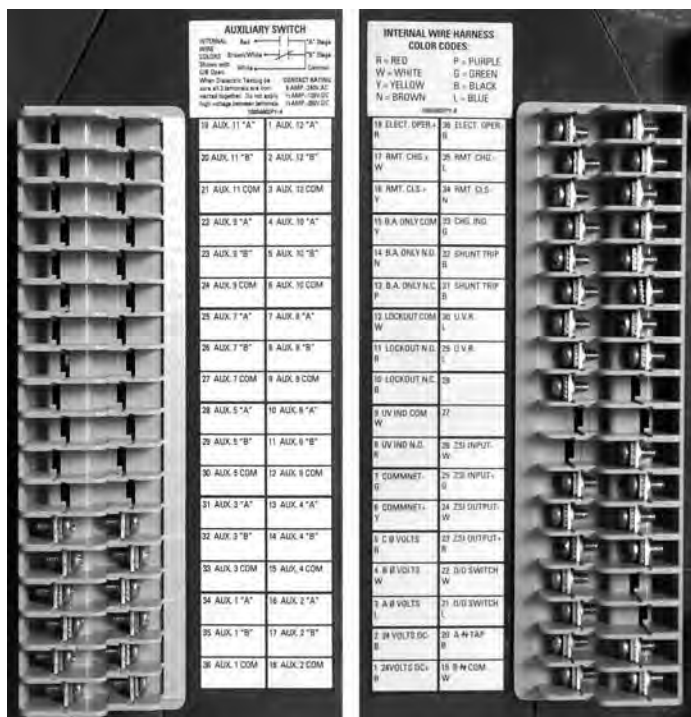

Left side secondary terminals "A" Block

Right side secondary terminals "B" Block

Time Current Tripping Characteristics

Power Break II insulated case circuit breaker time current curves are the engineering documents that define the technical performance of the devices. Information provided on a time current curve includes the following:

- Product family type (s)
- Specific device type (s)
- Ampere ratings covered on curve
- Overcurrent characteristics covered – long-time, short-time, instantaneous, etc.
- Maximum total clearing time
- Maximum and minimum temperature limits
- Frequency ratings
- Voltage ratings
- Specific trip unit ratings
- Trip unit adjustment ranges
- Tolerance (band width)

Multiples of circuit breaker trip ratings, or other suitable current value (e.g., current sensor rating) are shown on both the top and bottom horizontal axes. The time in seconds is shown on the vertical axes. Approximate minimum and maximum clearing time is readily determined from the characteristics curves. Tripping characteristics meet both NEMA and UL standards for rating and calibration.

Application

Time Current Curves Long-Time, Short-Time Delay and Instantaneous

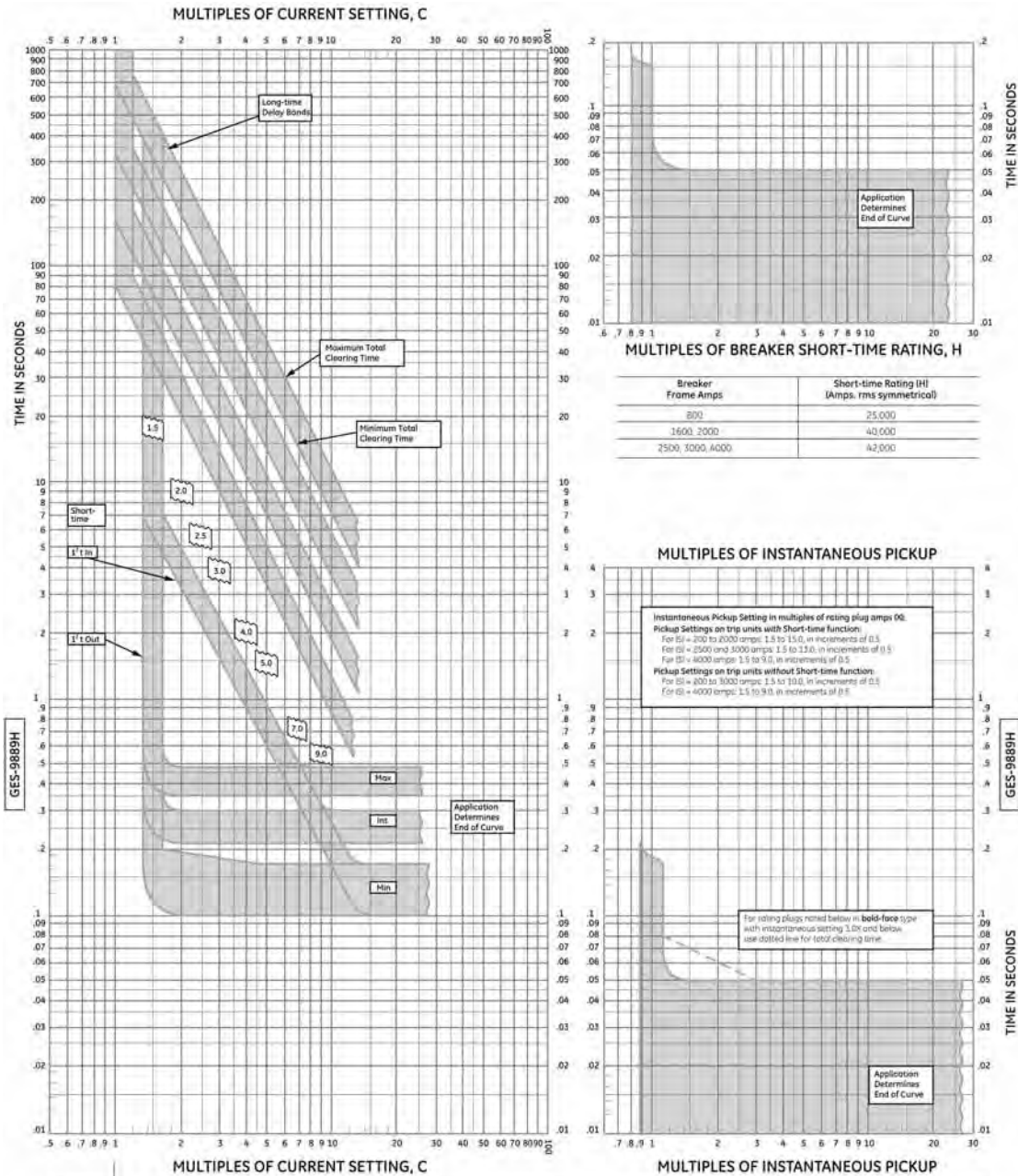

GE Consumer & Industrial - Electrical Distribution

Available Ratings (Amperes)

Frame	Current Sensor (S)	Rating Plug (H)
800	300	100, 150, 200
	400	150*, 200, 225, 250, 300, 400
	300*	400, 450, 500, 600, 700, 800
1600	800	300*, 400, 450, 500, 600, 700, 800
	1000	400*, 600, 800, 1000
	1600	600*, 800, 1000, 1100, 1200, 1600
3000	2500	750*, 800*, 1000, 1200, 1500, 1600, 2000
	2500	400*, 600, 800, 1000
4000	2000	800*, 1000, 1200, 1600, 2000
	2500	1600, 2000, 2500
	3000	2000, 2500, 3000*
4000	4000	1600, 2000, 2500, 3000, 4000

* Not available with Power+™ Trip Unit

Voltage Rating: 600 Vac, maximum

PowerBreak™ II Insulated Case Circuit Breakers

Types SS, SH with Power+™ MicroVersaTrip Plus™ or MicroVersaTrip PM™ Digital RMS Trip Units

Long-time Delay, Short-time Delay, and Instantaneous Time-Current Curves

Curves apply at 50 to 60 Hertz and from -20°C to 70°C breaker ambient

GES-9889H

Programmer Adjustments

Long-time Function Current Settings (IC): 0.50 to 1.0 multiples of rating plug amps (H).
Delay Bands: 1, 2, 3 and 4.

Short-time Function Pickup Settings: 1.5 to 9.0 multiples of current setting (IC).

Delay Bands: MIN, INT, MAX; I¹ In/Out

Instantaneous Function: See Table with Curves above (High-Range not available with Power+™)

S: Current Sensor Amps
X: Rating Plug Amps
C: Current Setting Amps
H: Breaker Short-time Rating Amps

Application

Time Current Curves Ground Fault

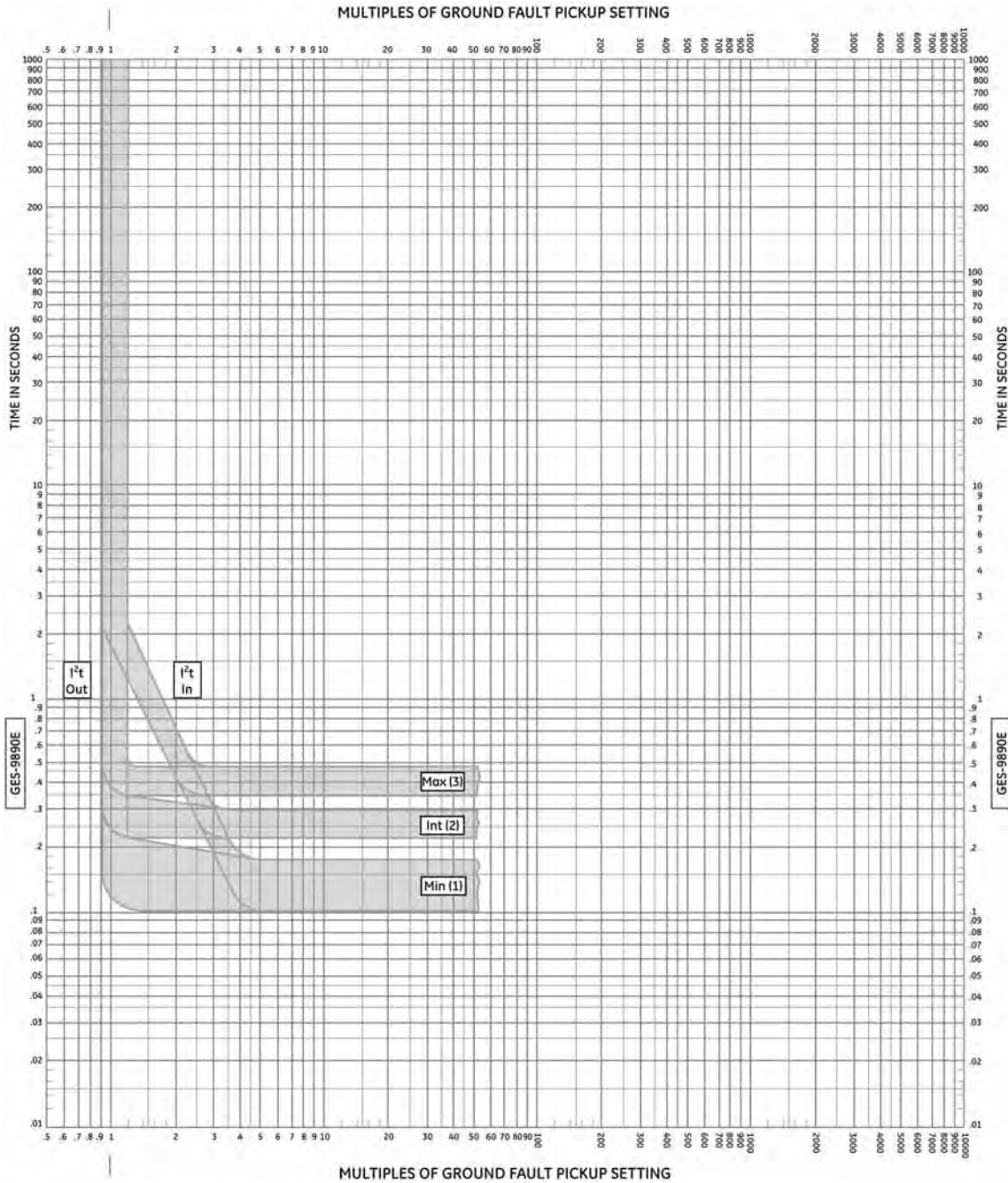

GE
GE Consumer & Industrial -
Electrical Distribution

Available Ratings (Amperes)

Frame	Current Sensor (S)
800	200, 400, 800
1600	800, 1000, 1600
2000	2000
2500	1000, 2000, 2500
3000	3000
4000	4000

Voltage Rating: 600 Vac, maximum

**Insulated Case Circuit Breakers
Power Break™ II**

Types SS, SH
with Power+™, MicroVersaTrip Plus® or
MicroVersaTrip® PM
Digital RMS Trip Units

Ground Fault Time-Current Curves

Curves apply at 50 to 60 Hertz
and from -20°C to +70°C breaker ambient.

GES-9890E

Adjustments
Ground Fault Function:
*Pickup settings are in multiples of Current Sensor Rating (S)
For (S) = 150 through 2500 amps
Pick-up setting: 0.20 to 0.60
For (S) = 2500 through 3000 amps
Pick-up setting: 0.20 to 0.37
For (S) = 4000 amps
Pick-up setting: 0.20 to 0.50
Delay Bands: Min (1), Int (2), Max (3), Flt In/Out

Settings Glossary
S = Current Sensor Rating in amps

04.97 BM

Application

Additional Time Current Curves

See the publications below for detailed Power Break® II time current curves.

EntelliGuard TU Trip Unit for Power Break II Circuit Breakers: Adjustable Selective Instantaneous Trip and HSIOC (override)	DES-100
EntelliGuard TU Trip Unit for Power Break, Power Break II, AKR, and WavePro Circuit Breakers; Ground Fault	DES-098A
EntelliGuard TU Trip Unit for Power Break, Power Break II, AKR, and WavePro Circuit Breakers; Long-Time CB Characteristics)	DES-095
EntelliGuard TU Trip Unit for Power Break, Power Break II, AKR and WavePro Circuit Breakers; Long-Time Fuse Like Characteristic	DES-096
EntelliGuard TU Trip Unit for Power Break, Power Break II, AKR and WavePro Circuit Breakers; Short-time Pickup and Delay Bands	DES-097

Physical Data

Power Break® II 800- Amp Stationary

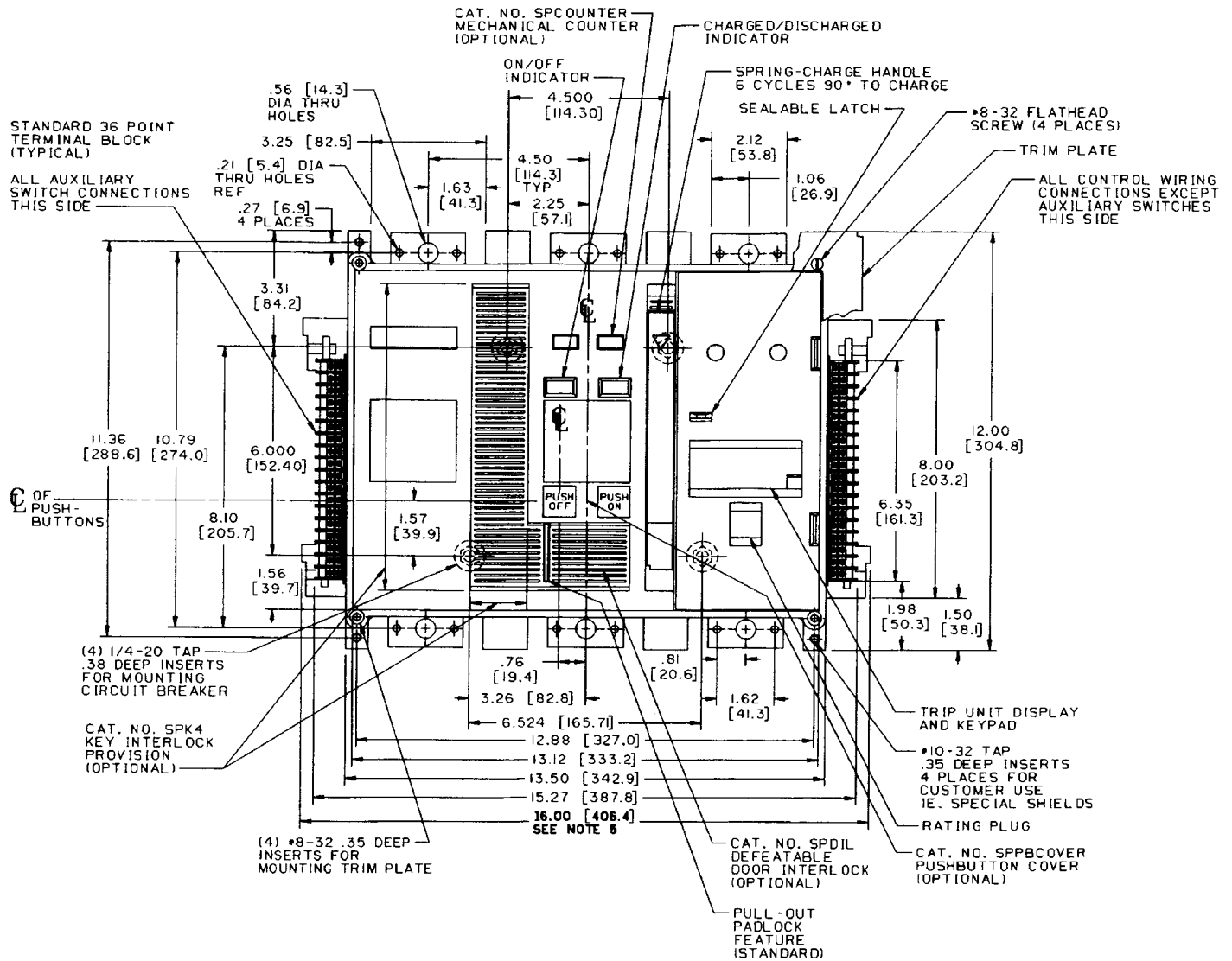

1. 1/4 - 20 mounting bolts to be furnished by customer.
2. To prevent heating, do not mount breaker to magnetic steel back support.
3. All outline dimensions are the same for manually and electrically operated devices.
4. Dimensions in brackets are in [millimeters].
5. 4.50 [114.3] minimum distance above breaker to metal in an area 5.31 x 16.00 [134.9 x 406.4] due to arc chamber venting.

Physical Data

Power Break® II 800-Amp Stationary

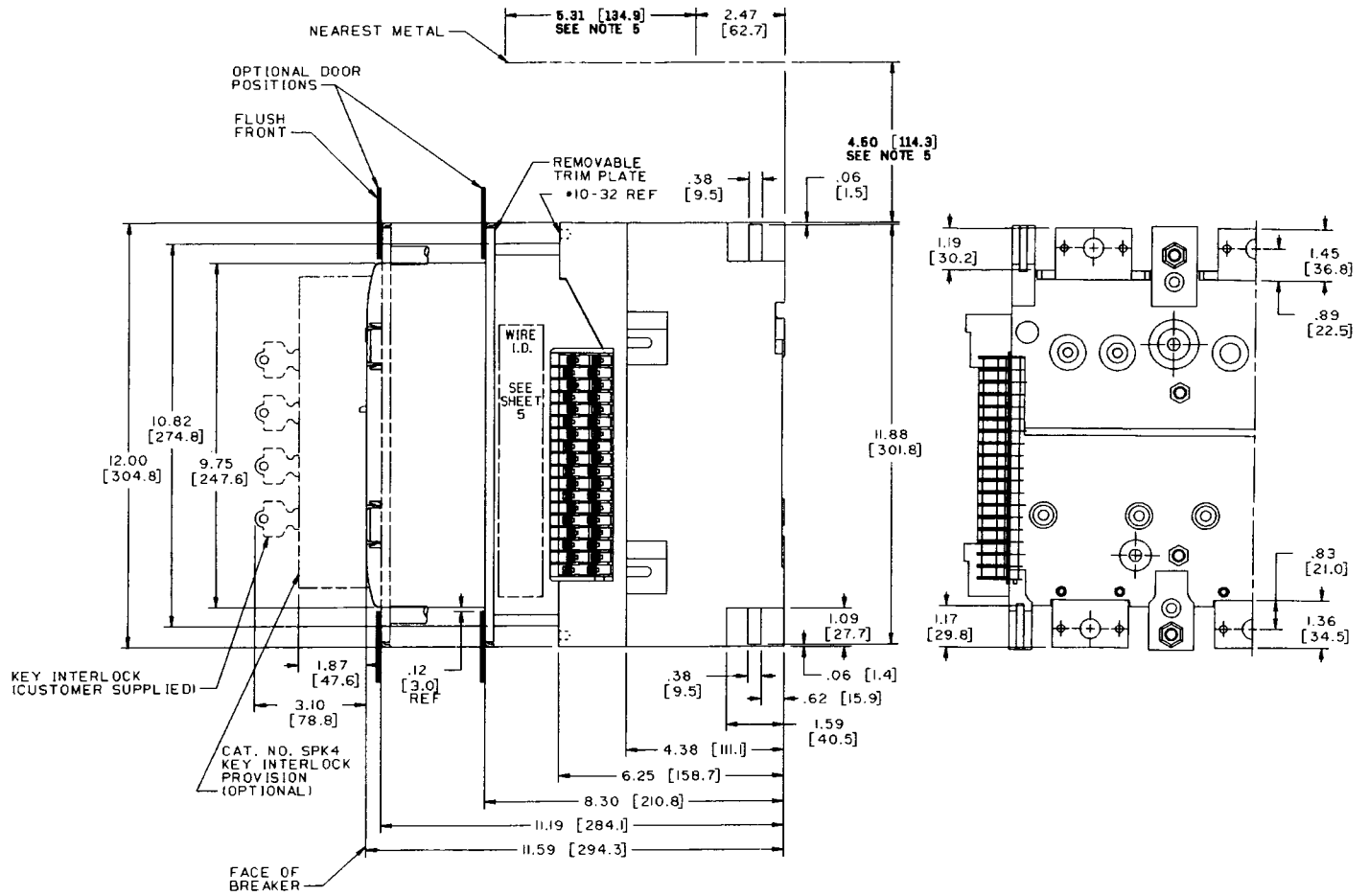

1. ¼ - 20 mounting bolts to be furnished by customer.
2. To prevent heating, do not mount breaker to magnetic steel back support.
3. All outline dimensions are the same for manually and electrically operated devices.
4. Dimensions in brackets are in [millimeters].
5. 4.50 [114.3] minimum distance above breaker to metal in an area 5.31 x 16.00 [134.9 x 406.4] due to arc chamber venting.

Physical Data

Power Break® II 1600-2000- Amp Stationary

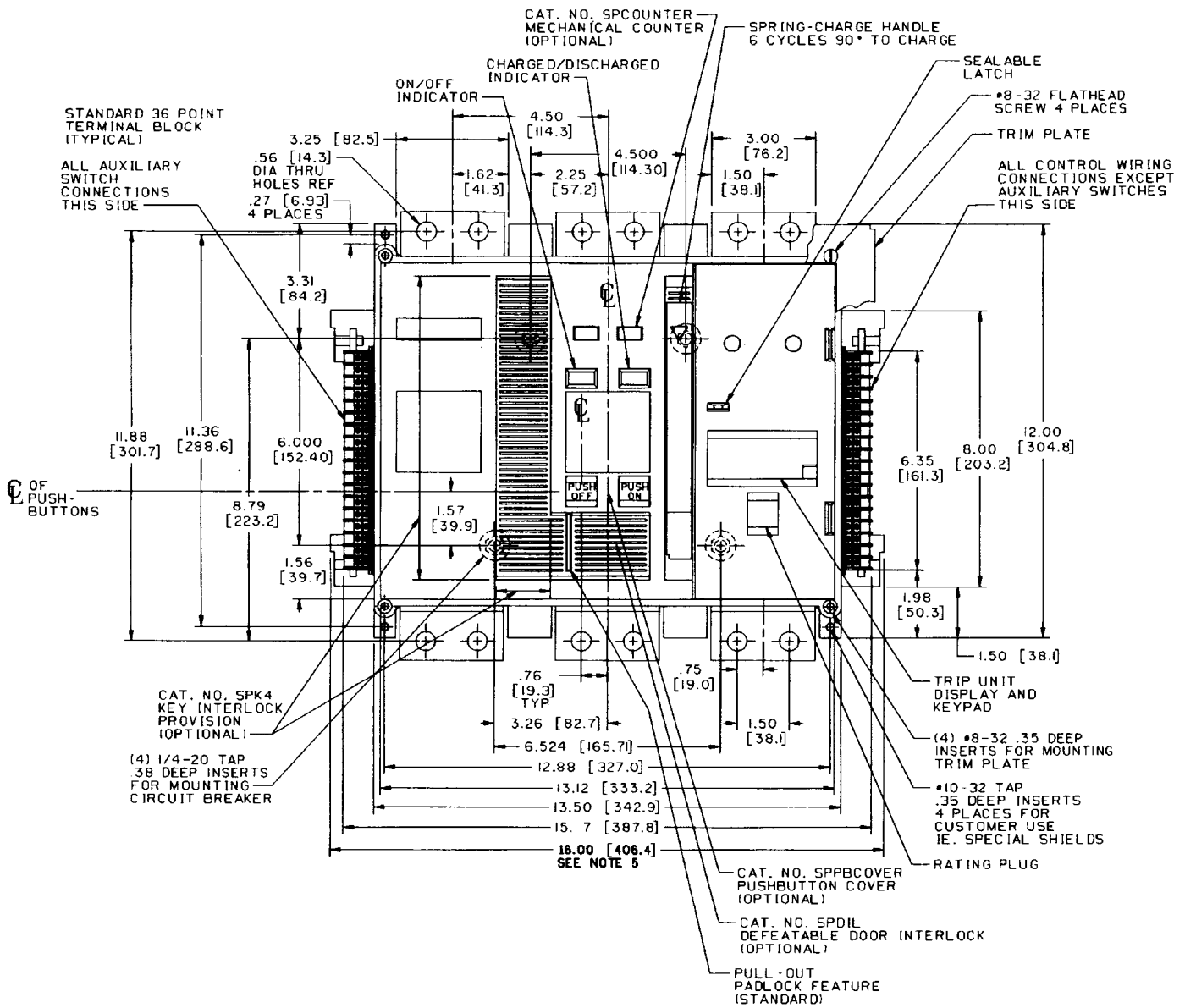

1. ¼ - 20 mounting bolts to be furnished by customer.
2. To prevent heating, do not mount breaker to magnetic steel back support.
3. All outline dimensions are the same for manually and electrically operated devices.
4. Dimensions in brackets are in [millimeters].
5. 4.50 [114.3] minimum distance above breaker to metal in an area 5.31 x 16.00 [134.9 x 406.4] due to arc chamber venting.

Physical Data

Power Break® II 1600-2000-Amp Stationary

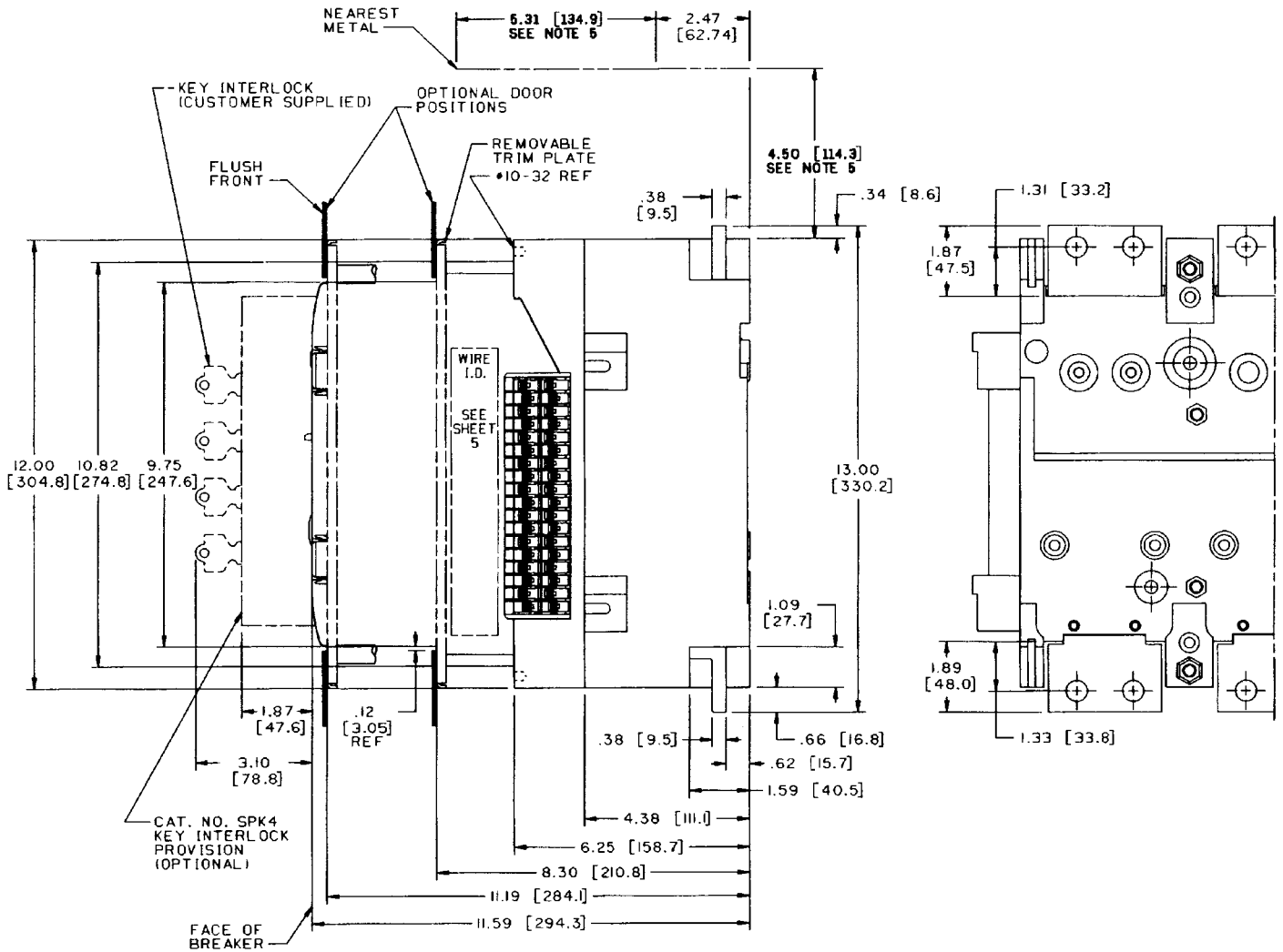

1. ¼ - 20 mounting bolts to be furnished by customer.
2. To prevent heating, do not mount breaker to magnetic steel back support.
3. All outline dimensions are the same for manually and electrically operated devices.
4. Dimensions in brackets are in [millimeters].
5. 4.50 [114.3] minimum distance above breaker to metal in an area 5.31 x 16.00 [134.9 x 406.4] due to arc chamber venting.

Physical Data

Power Break® II 800-Amp Drawout

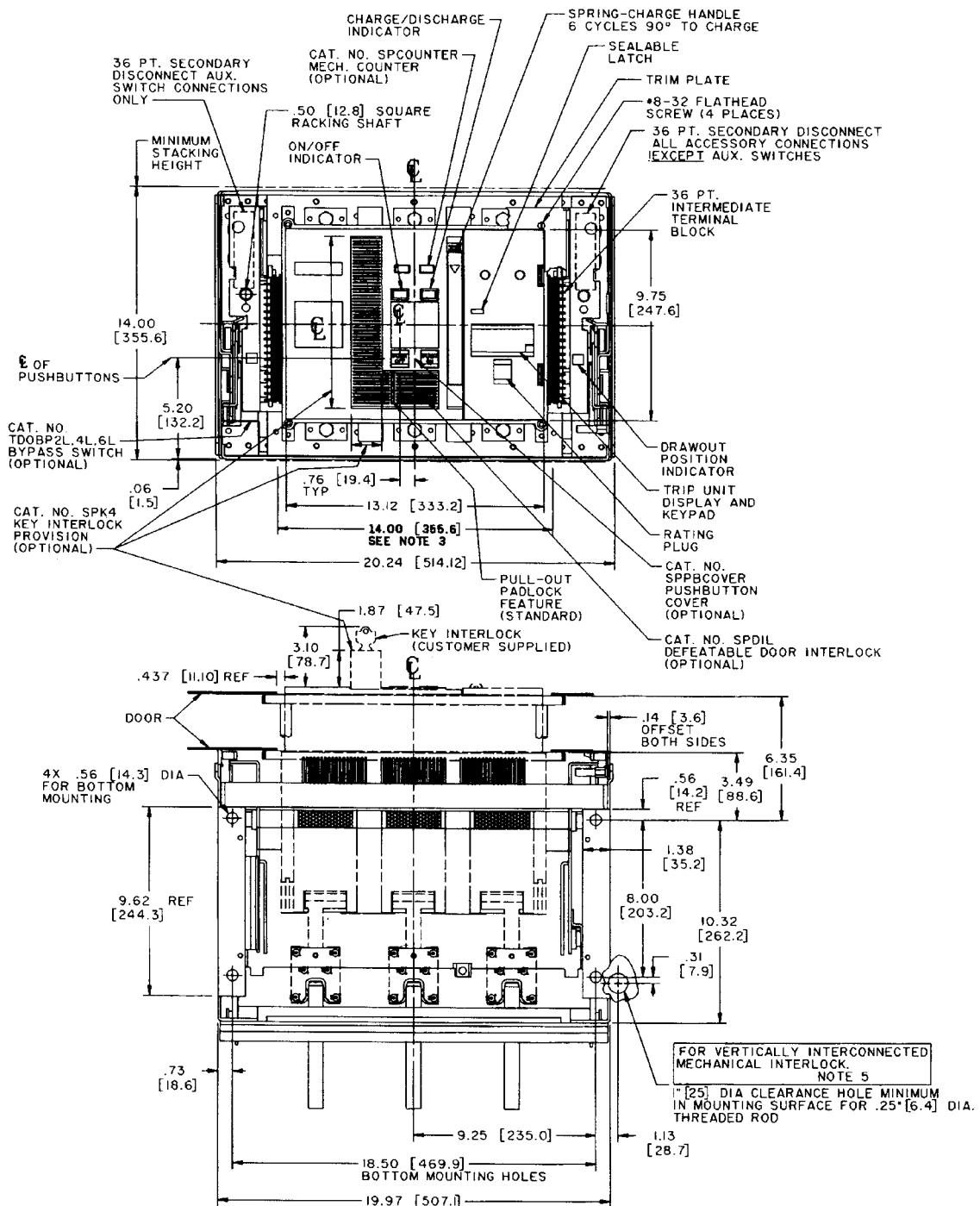

1. All outline dimensions are the same for manually and electrically operated devices.
2. Dimensions in brackets are in [millimeters].
3. Any compartment metal in 6.50 X 14.00 [165.1 x 355.6] area below (and above at 1600A, minimum stacking height) must be removed. Reference UL891 dead-front switchboards standard-electrical spacing requirements.
4. 3.74 [95] minimum distance above substructure to any metal in an are 5.31 x 16.00 [134.9 x 406.4] due to arc chamber venting.
5. Customer's location for drilling hole for horizontally or vertically interconnected mechanical interlock. See bottom or side view.

Physical Data

Power Break® II 800-Amp Drawout

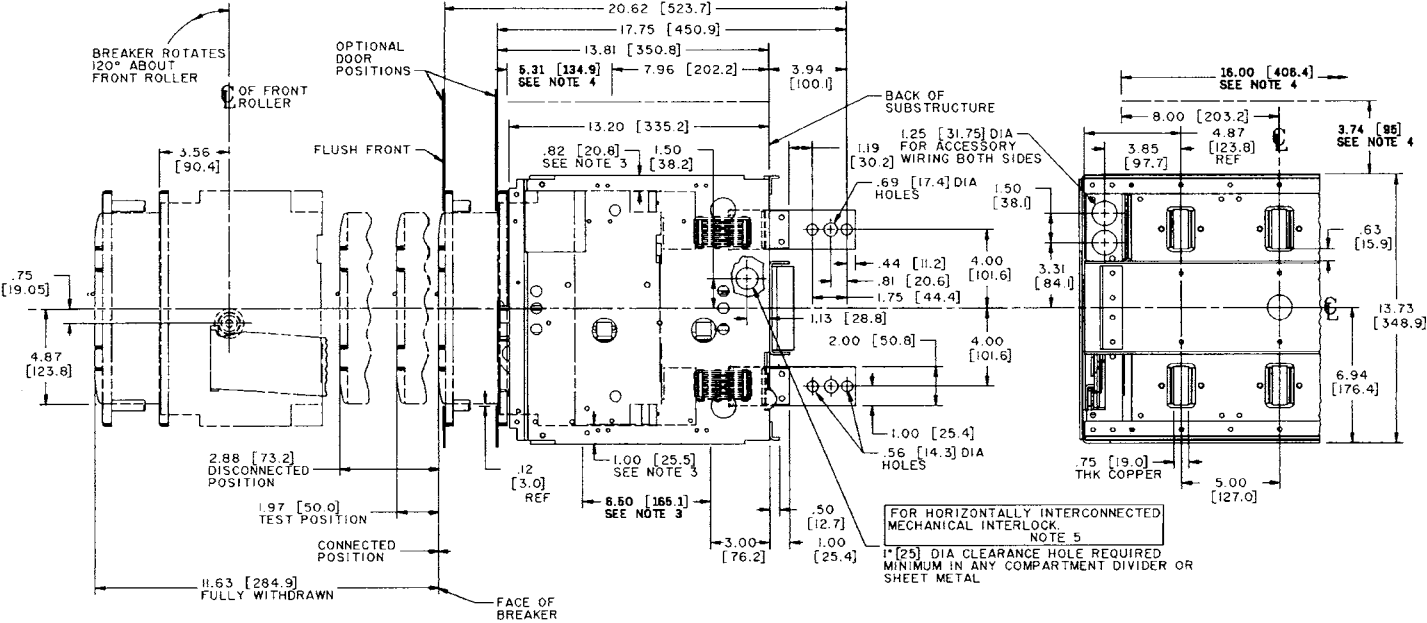

1. All outline dimensions are the same for manually and electrically operated devices.
2. Dimensions in brackets are in (millimeters).
3. Any compartment metal in 6.50 X 14.00 [165.1 x 355.6] area below (and above at 1600A, minimum stacking height) must be removed. Reference UL891 dead-front switchboards standard-electrical spacing requirements.
4. 3.74 [95] minimum distance above substructure to any metal in an arc 5.31 x 16.00 [134.9 x 406.4] due to arc chamber venting.
5. Customer's location for drilling hole for horizontally or vertically interconnected mechanical interlock. See bottom or side view.

Physical Data

Power Break® II 1600-2000-Amp Drawout

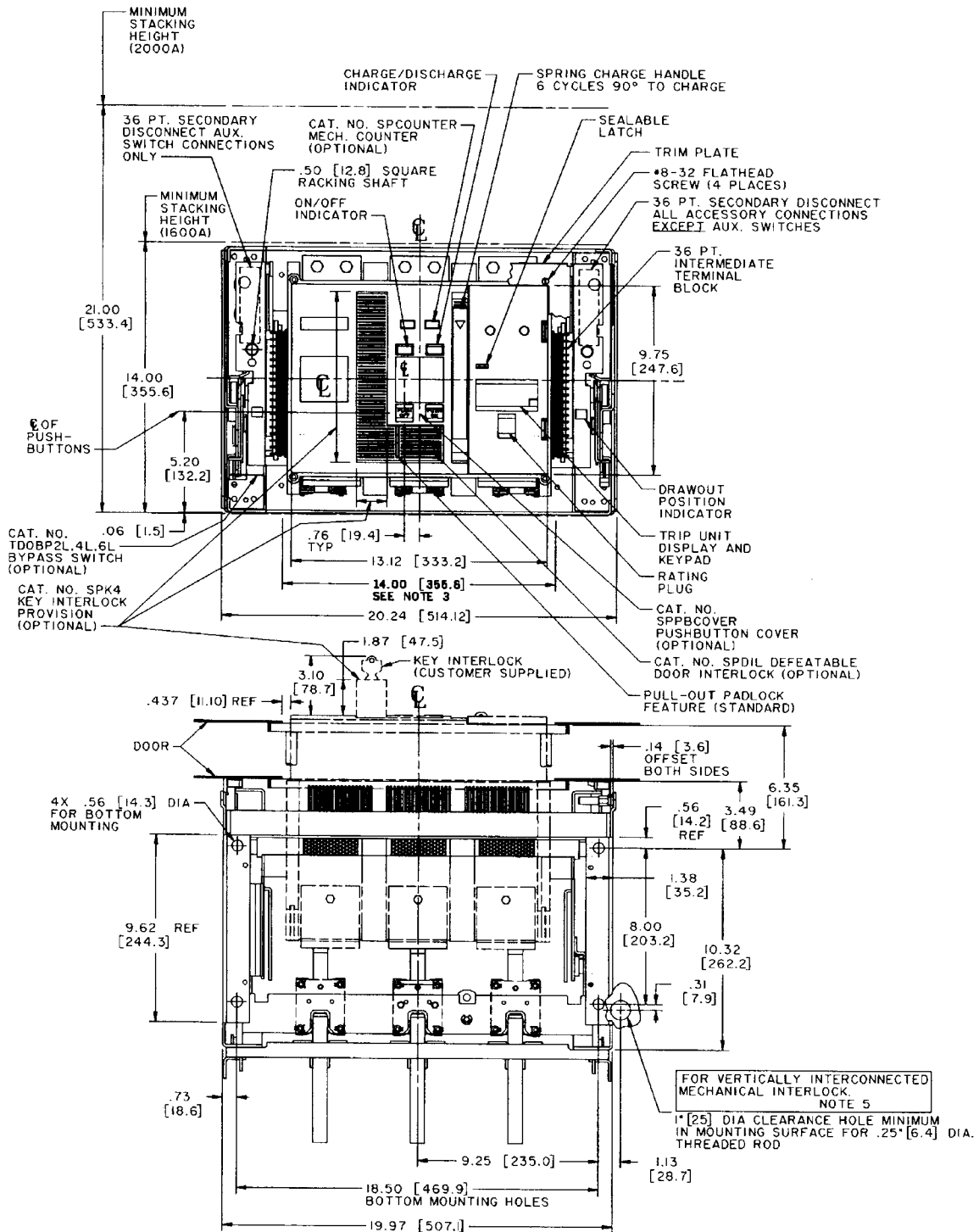

1. All outline dimensions are the same for manually and electrically operated devices.
2. Dimensions in brackets are in [millimeters].
3. Any compartment metal in 10.00 X 14.00 [254.0 x 355.6] are below (and above at 1600A, minimum stacking height) must be removed. Reference UL891 dead-front switchboards standard-electrical spacing requirements.
4. 3.74 [95] minimum distance above substructure to any metal in an are 53.1 x 16.00 [134.9 x 406.4] due to arc chamber venting.
5. Customer's location for drilling hole for horizontally or vertically interconnected mechanical interlock. See bottom or side view.

Physical Data

Power Break® II 1600-2000-Amp Drawout

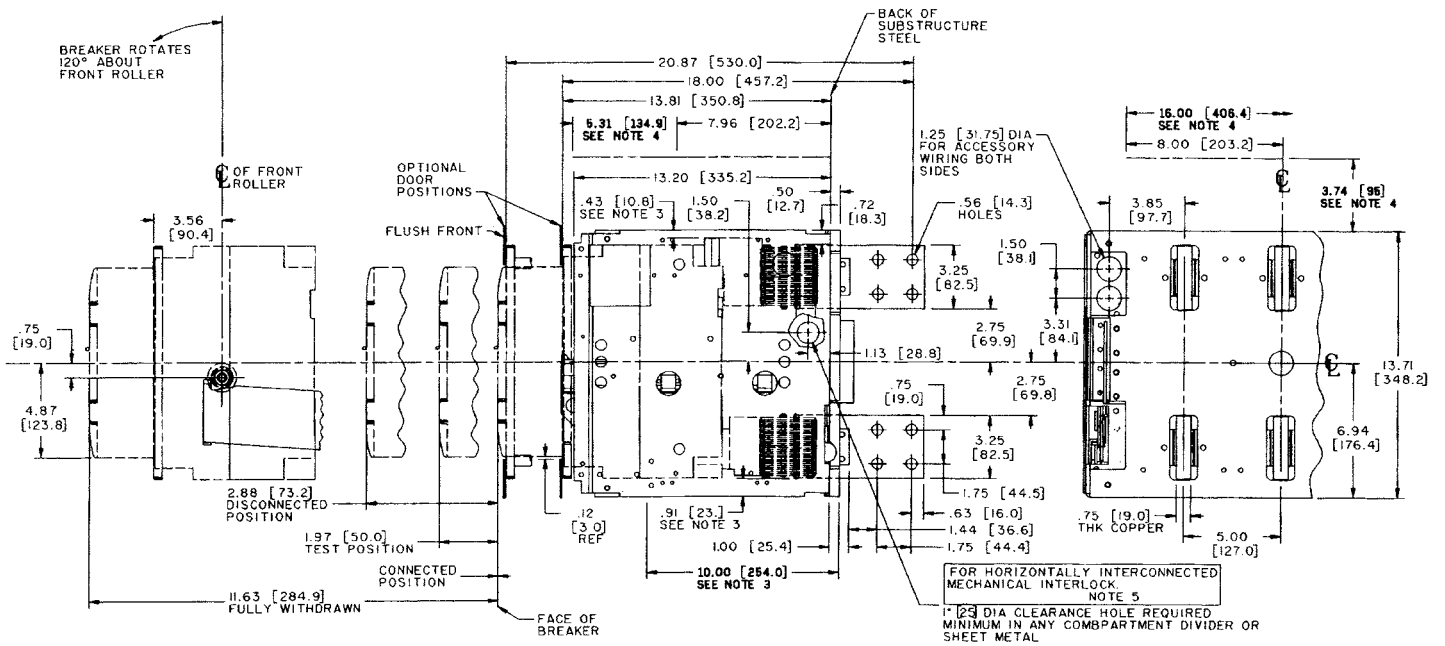

1. All outline dimensions are the same for manually and electrically operated devices.
2. Dimensions in brackets are in [millimeters].
3. Any compartment metal in 10.00 x 14.00 [254.0 x 355.6] area below (and above at 1600A minimum stacking height) must be removed. Reference UL891 dead-front switchboards standard-electrical spacing requirements.
4. 3.74 [95] minimum distance above substructure to any metal in an area 5.31 x 16.00 [134.9 x 406.4] due to arc chamber venting.
5. Customer's location for drilling hole for horizontally or vertically interconnected mechanical interlock. See bottom or side view.

Physical Data

Power Break® II Information, 800-2000-Amp Frames

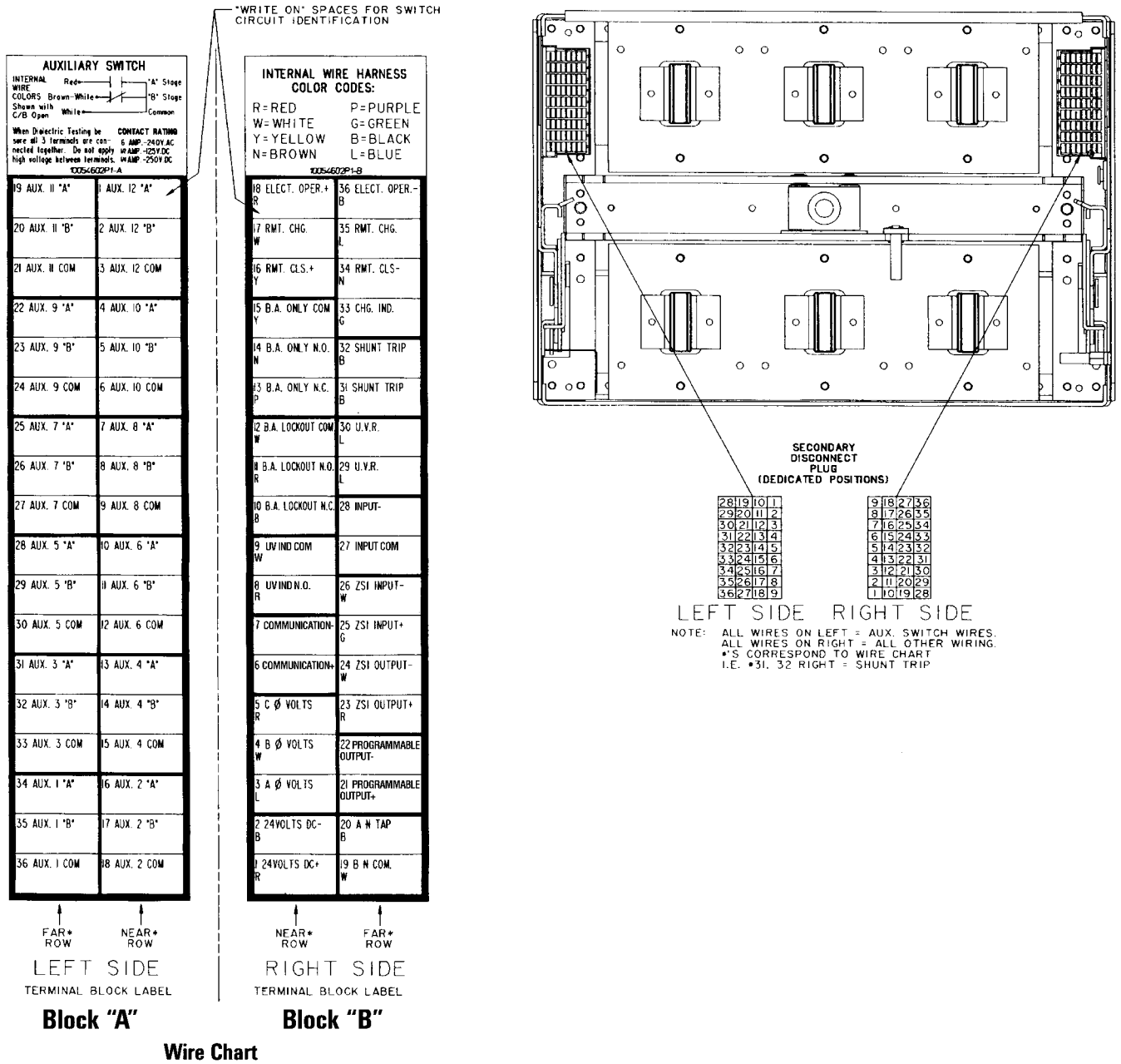

* Screw terminal position relative to front of circuit breaker
Note: Wire range #18 thru #12 solid or stranded copper wire. Torque: 9lb-in.

1. Dimensions in brackets are [metric].
2. Busbars or cables should be sized per UL891 dead-front switchboards standard.

Physical Data

Power Break® II Information, 800-2000-Amp Frames

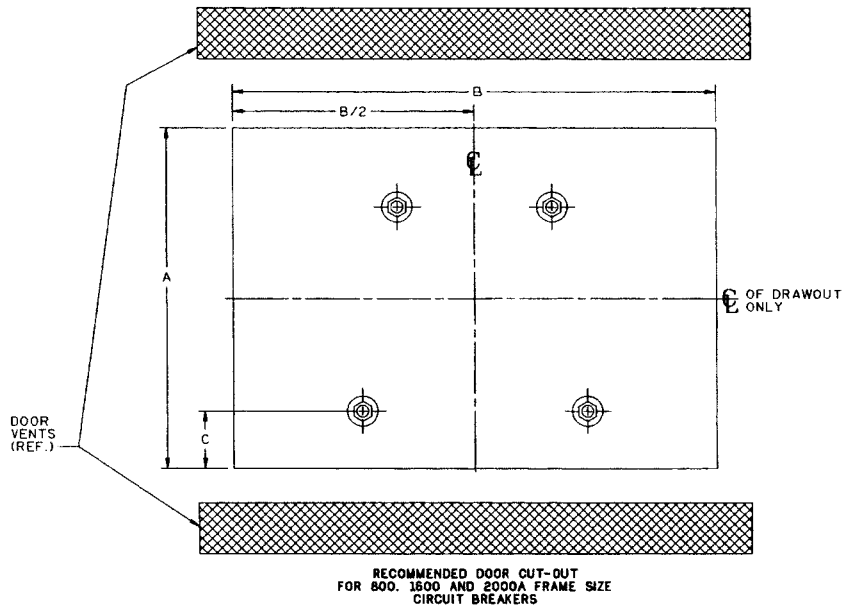

Table 71.1

Frame Rating	Breaker Type	Weight		Minimum Compartment Volume	Minimum Door Ventilation	Standard Door Cut-Out			Optional Door Cut- Out		
		Breaker	Drawout Substructure			A	B	C	A	B	C
800A	Stationary Mounted	71 lbs.* [32,3 kg]	N/A	3447 cu. in. [56486 cu. cm]	None	10 [254]	14 [356]	1.69 [42.9]	9.83 [249.7]	13.38 [339.9]	1.605 [40.8]
1600A		60.0 sq. in. [387,1 sq. cm] Total 30.0 sq. in. [193,5 sq. cm] Top 30.0 sq. in. [193,5 sq. cm] Bottom									
2000A		86.4 sq. in. [557,4 sq. cm] Total 43.2 sq. in. [278,7 sq. cm] Top 43.2 sq. in. [278,7 sq. cm] Bottom									
						Trim Plate Required			Flush Front or Non-hinged Door Construction - Trim Plate may be omitted		
800A	Drawout Mounted	106 lbs.* [48,2 kg]	54 lbs. [24,5 kg]	3780 cu. in. [61943 cu. cm]	None	10 [254]	14 [356]	N/A	9.83 [249.7]	13.38 [339.9]	N/A
1600A		None									
2000A		125 lbs.* [56,8 kg]	68 lbs. [30,9 kg]	5670 cu. in. [92915 cu. cm]	34.2 sq. in. [220,6 sq. cm] Total 29.5 sq. in. [190,3 sq. cm] Top 4.66 sq. in. [30,0 sq. cm] Bottom						
						Trim Plate Required			Flush Front or Non-hinged Door Construction - Trim Plate may be omitted		

N/A = Not Applicable

* Add 9 lbs. [4.1 kg] for electrical operator

1. Dimensions in brackets are [metric].
2. Busbars or cables should be sized per UL891 dead-front switchboards standard.

Physical Data

Power Break® II 2500-3000-Amp Front Connected

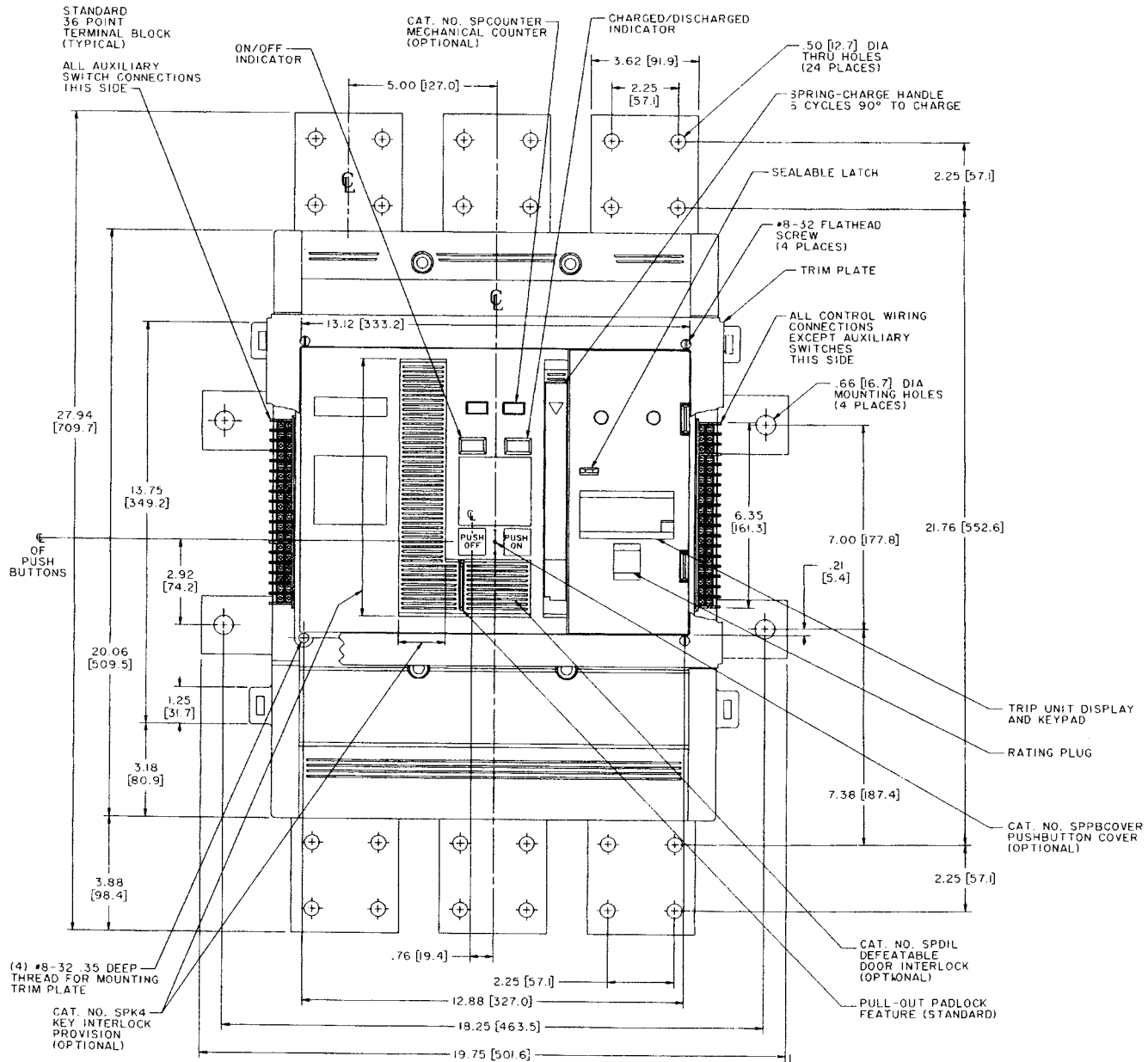

1. All outline dimensions are the same for manually and electrically operated devices.
2. Dimensions in brackets are in (millimeters).
3. 8.00 [203.2] minimum distance above breaker to metal due to arc chute venting.

Physical Data

Power Break® II 2500-3000-Amp Front Connected

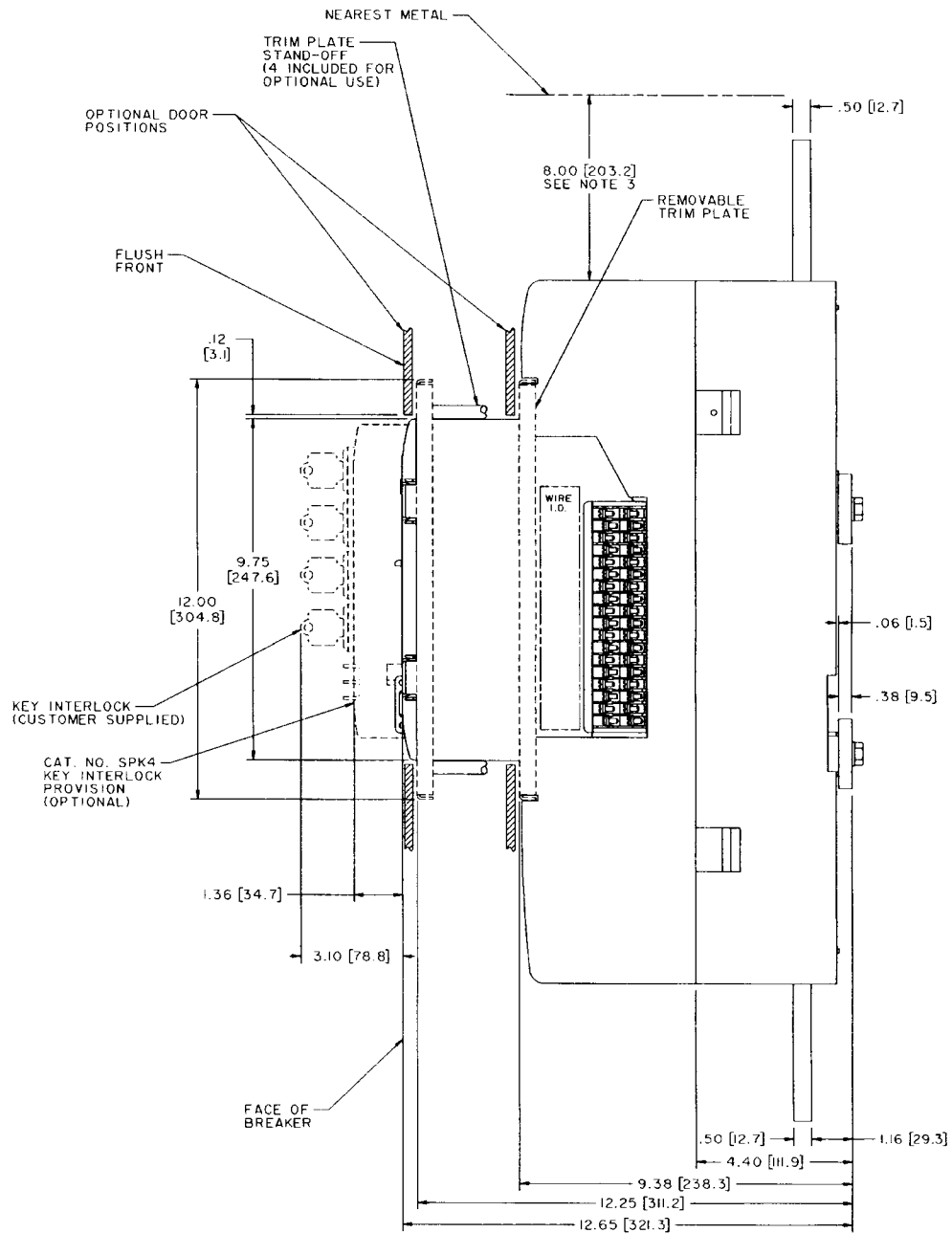

1. All outline dimensions are the same for manually and electrically operated devices.
2. Dimensions in brackets are in [millimeters].
3. 8.00 [203,2] minimum distance above breaker to metal due to arc chute venting.

Physical Data

Power Break® II 2500-Amp Back Connected

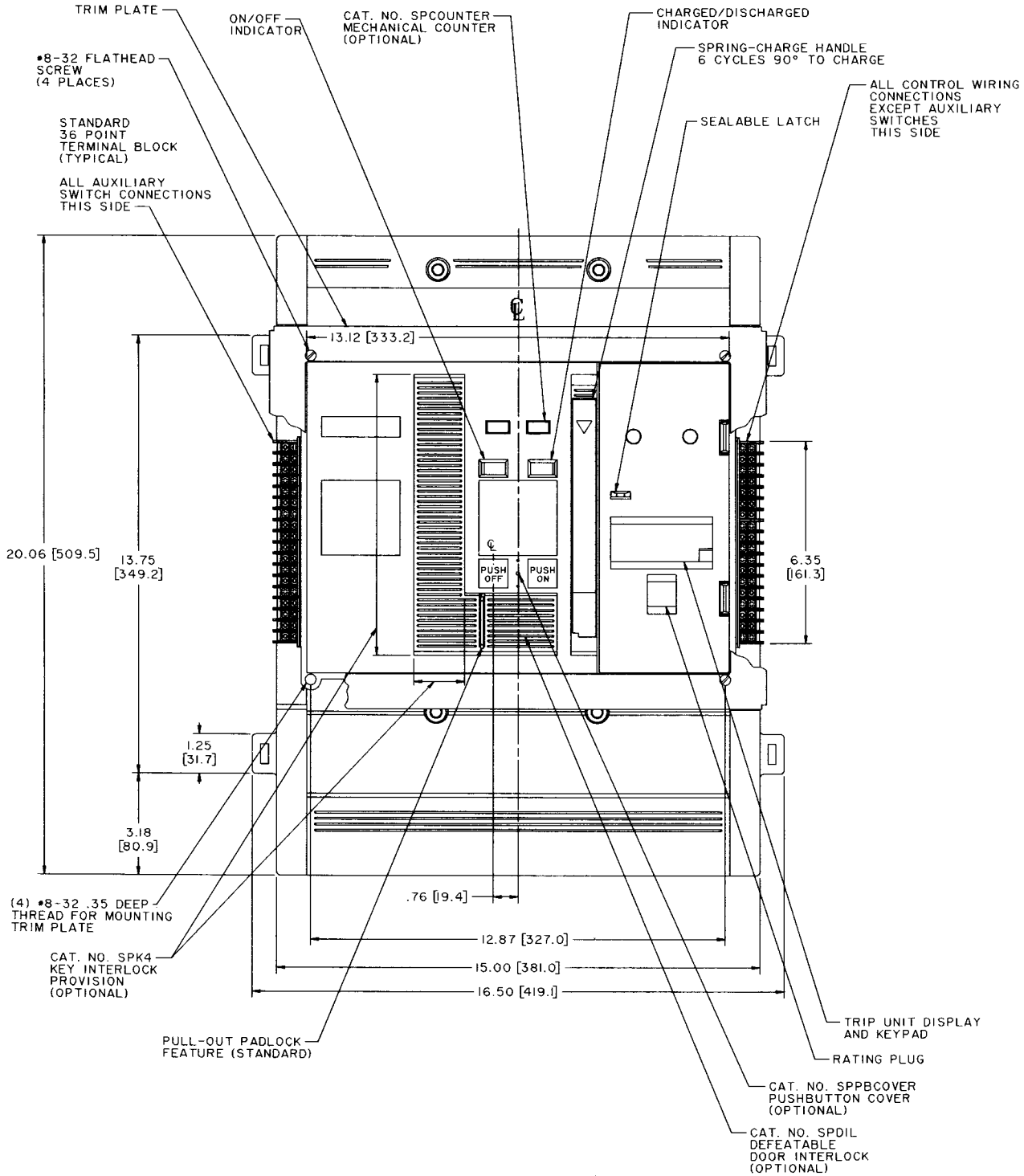

1. All outline dimensions are the same for manually and electrically operated devices.
2. Dimensions in brackets are in [millimeters].
3. 8.00 [203,2] minimum distance above breaker to metal due to arc chute venting.

Physical Data

Power Break® II 2500-Amp Back Connected

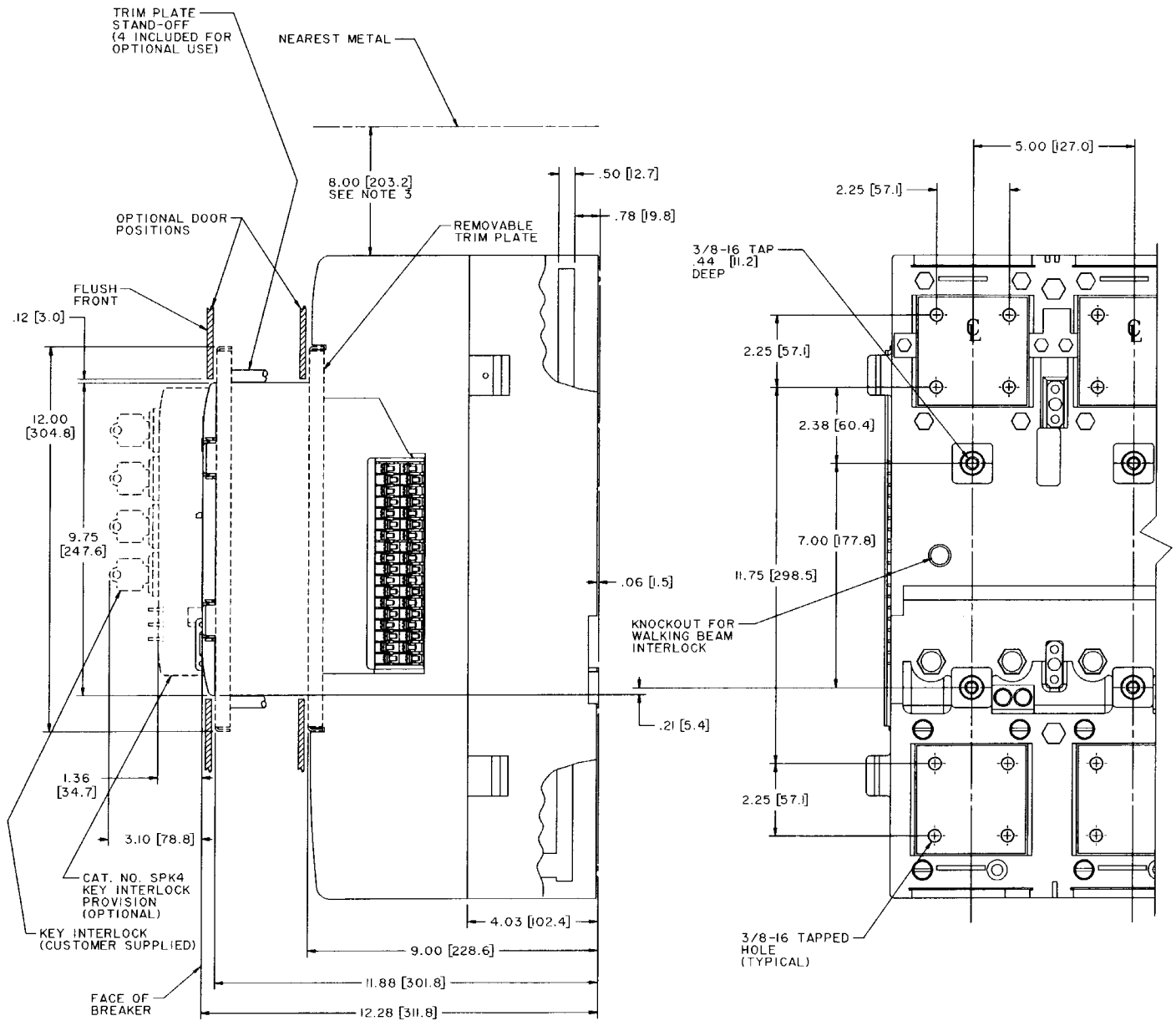

1. All outline dimensions are the same for manually and electrically operated devices.
2. Dimensions in brackets are in [millimeters].
3. 8.00 [203,2] minimum distance above breaker to metal due to arc chute venting.

Physical Data

Power Break® II 3000-Amp Back Connected

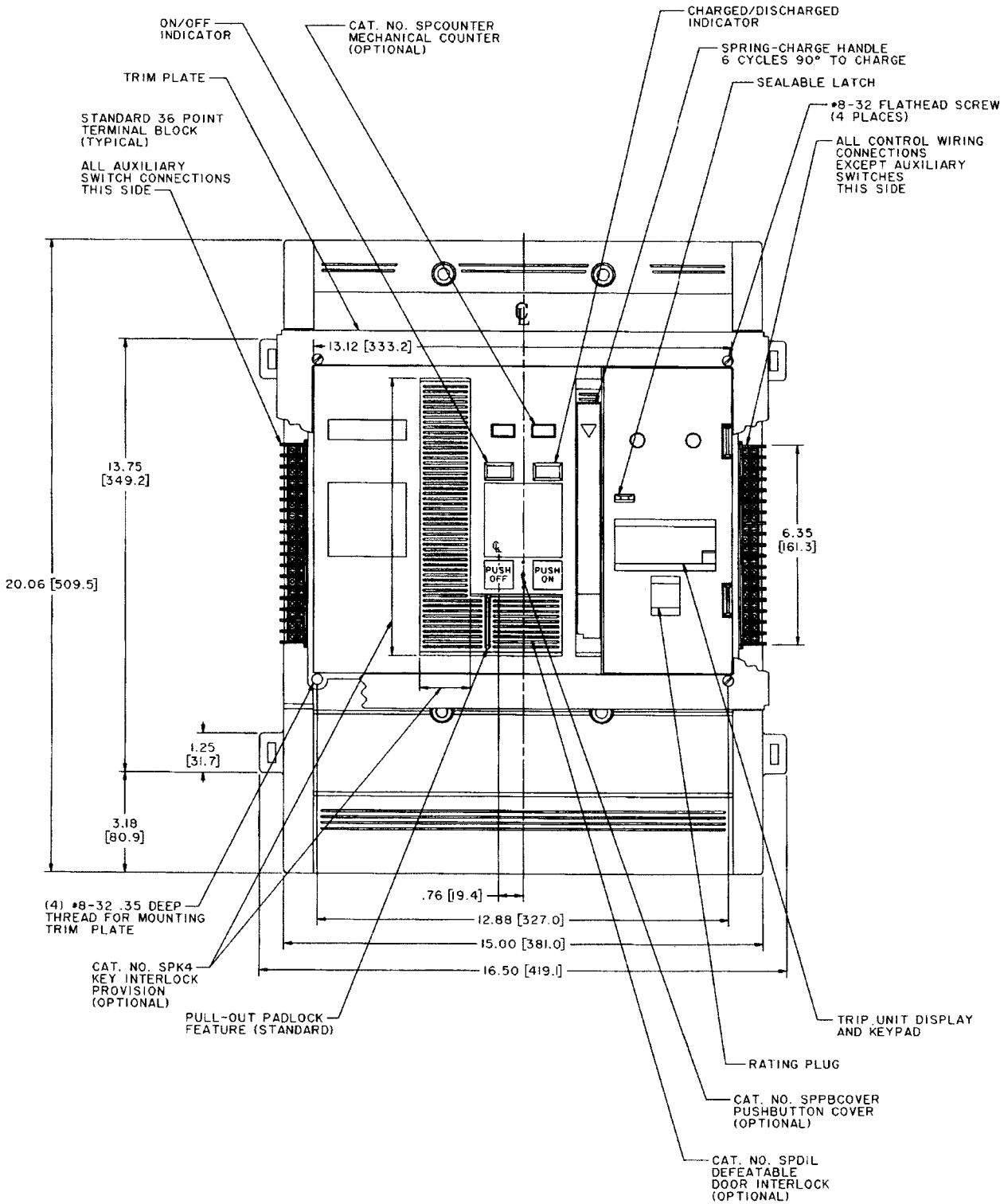

1. All outline dimensions are the same for manually and electrically operated devices.
2. Dimensions in brackets are in [millimeters].
3. 8.00 [203.2] minimum distance above breaker to metal due to arc chute venting.

Physical Data

Power Break® II 3000-Amp Back Connected

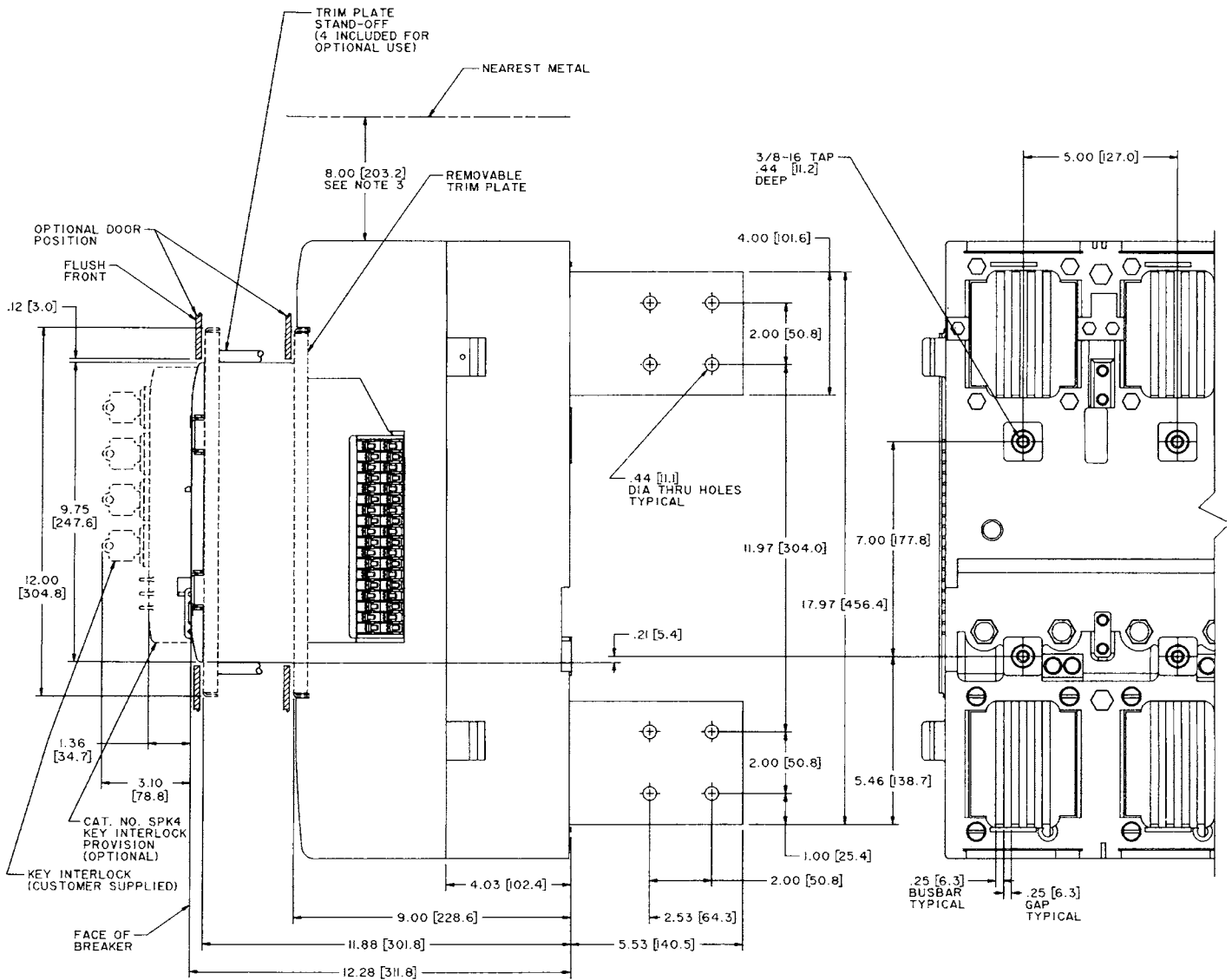

1. All outline dimensions are the same for manually and electrically operated devices.
2. Dimensions in brackets are in (millimeters).
3. 8.00 [203.2] minimum distance above breaker to metal due to arc chute venting.

Physical Data

Power Break® II 4000-Amp Front Connected

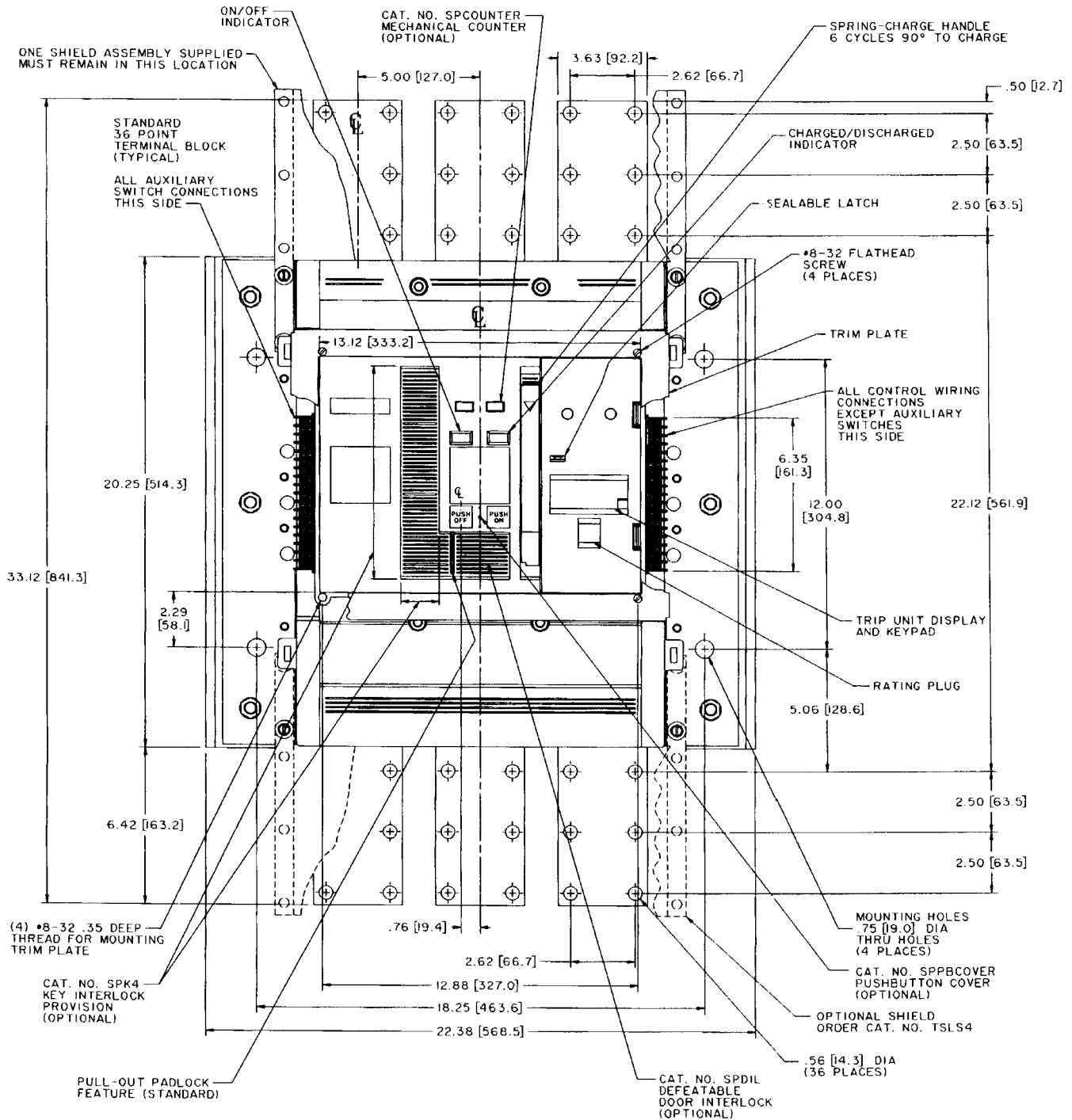

1. All outline dimensions are the same for manually and electrically operated devices.
2. Dimensions in brackets are in [millimeters].
3. 8.00 [203.2] minimum distance above breaker to metal due to arc chute venting.

Physical Data

Power Break® II 4000-Amp Front Connected

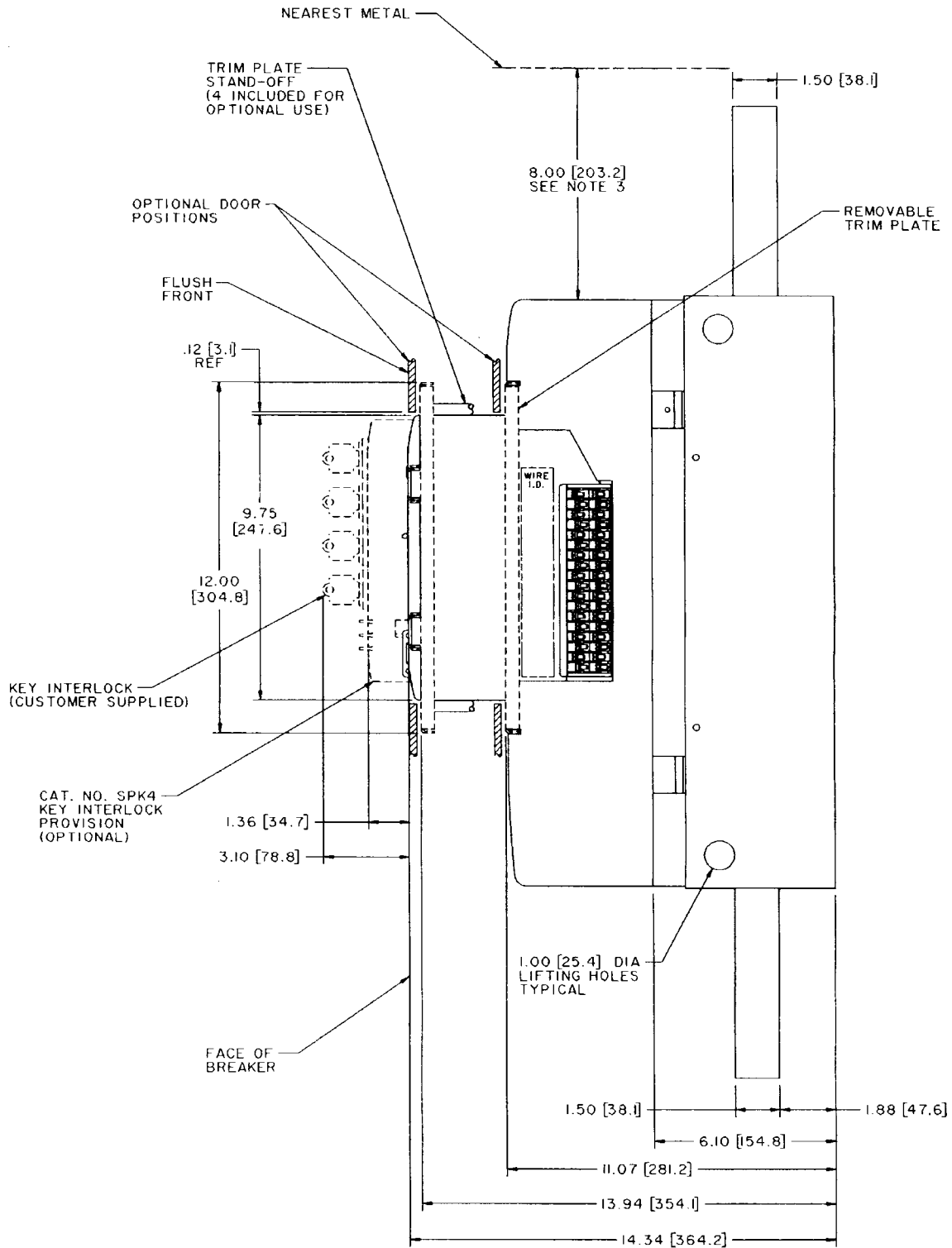

1. All outline dimensions are the same for manually and electrically operated devices.
2. Dimensions in brackets are in [millimeters].
3. 8.00 [203,2] minimum distance above breaker to metal due to arc chute venting.

Physical Data

Power Break® II 2500-3000 Amp Drawout

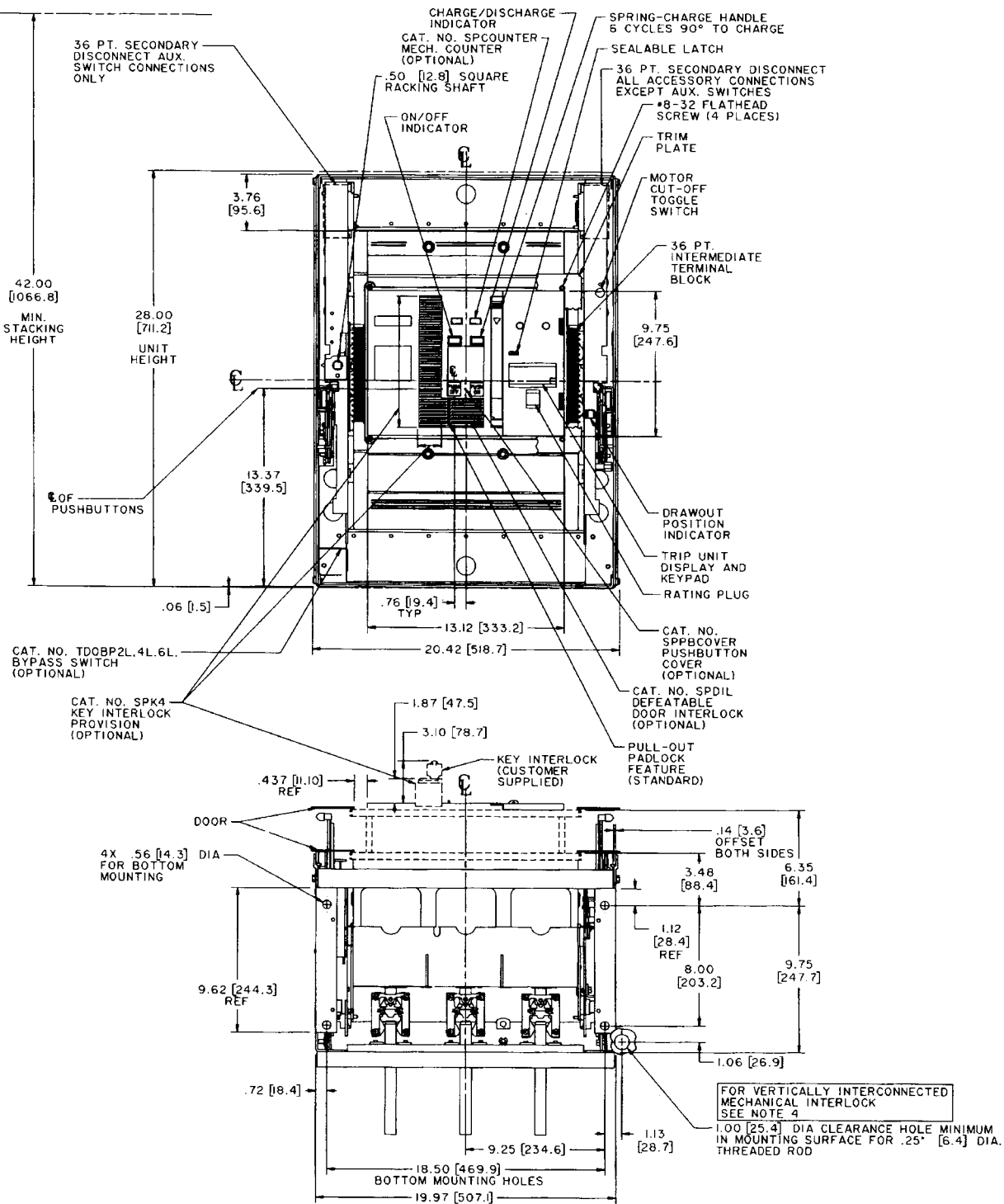

1. All outline dimensions are the same for manually and electrically operated devices.
2. Dimensions in brackets are in [millimeters].
3. 4.25 [108] minimum distance above substructure (8.00 [203.2] from top of circuit breaker) to any metal in an area 9.00 x 16.00 [228,6 x 406,4] due to arc chamber venting.
4. Customer's location for drilling hole for horizontally or vertically interconnected mechanical interlock, See bottom or side view.

Physical Data

Power Break® II 2500-3000 Amp Drawout

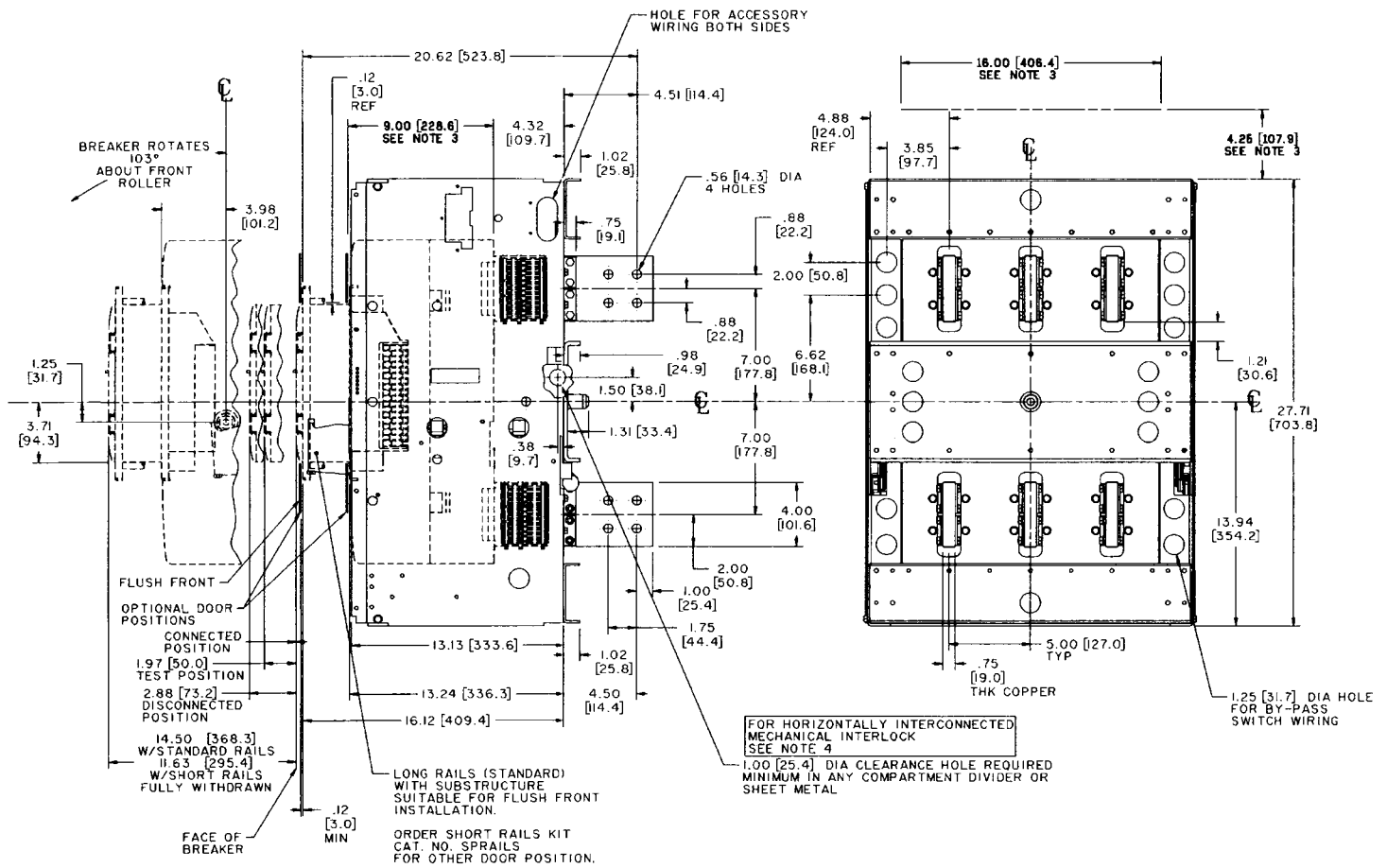

1. All outline dimensions are the same for manually and electrically operated devices.
2. Dimensions in brackets are in [millimeters].
3. 4.25 [108] minimum distance above substructure (8.00 [203.2] from top of circuit breaker) to any metal in an area 9.00 x 16.00 [228,6 x 406,4] due to arc chamber venting.
4. Customer's location for drilling hole for horizontally or vertically interconnected mechanical interlock, See bottom or side view.

Physical Data

Power Break® II 4000 Amp Drawout

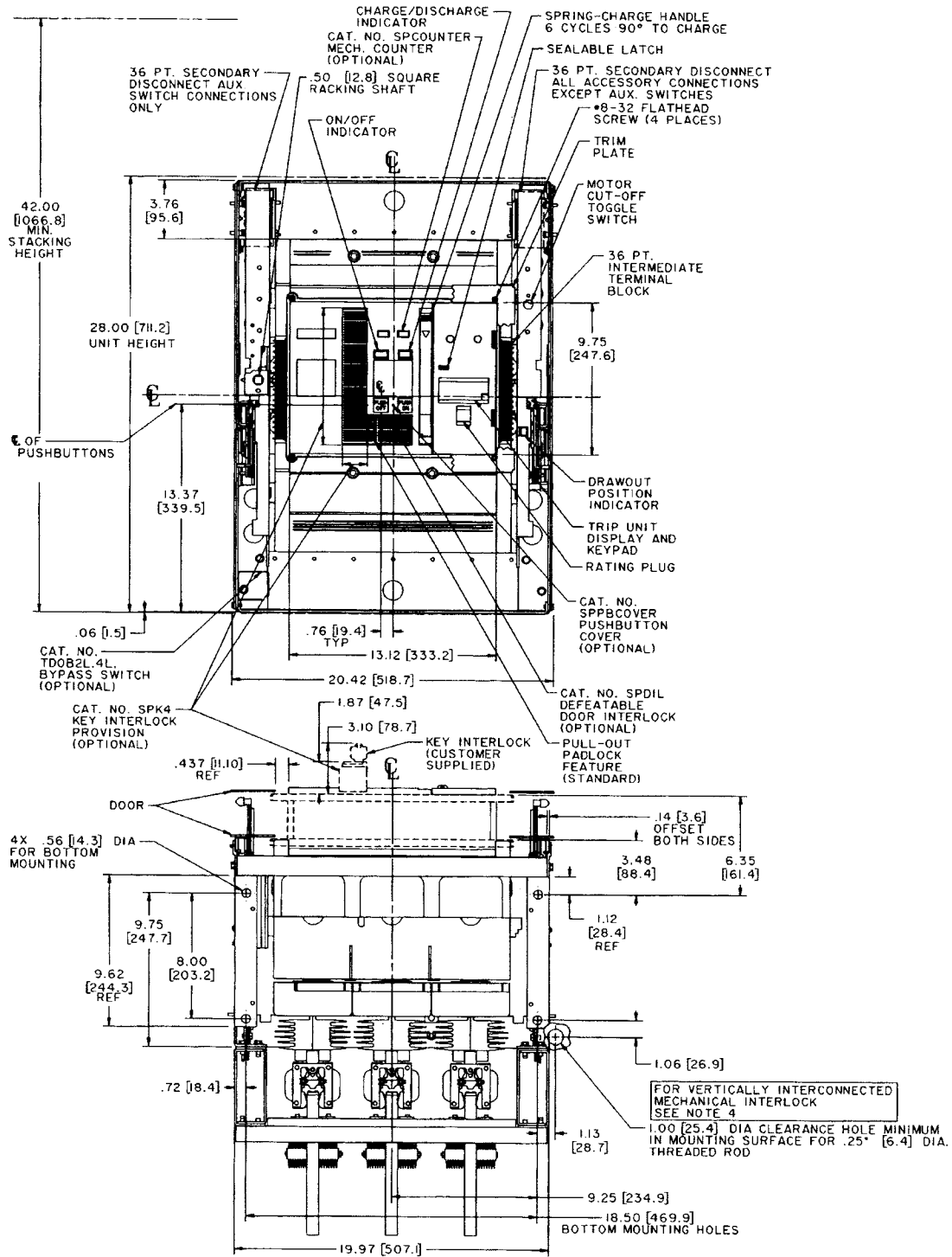

1. All outline dimensions are the same for manually and electrically operated devices.
2. Dimensions in brackets are in [millimeters].
3. 4.25 [108] minimum distance above substructure (8.00 [203.2] from top of circuit breaker) to any metal in an area 9.00 x 16.00 [228,6 x 406,4] due to arc chamber venting.
4. Customer's location for drilling hole for horizontally or vertically interconnected mechanical interlock. See bottom or side view.

Physical Data

Power Break® II 4000 Amp Drawout

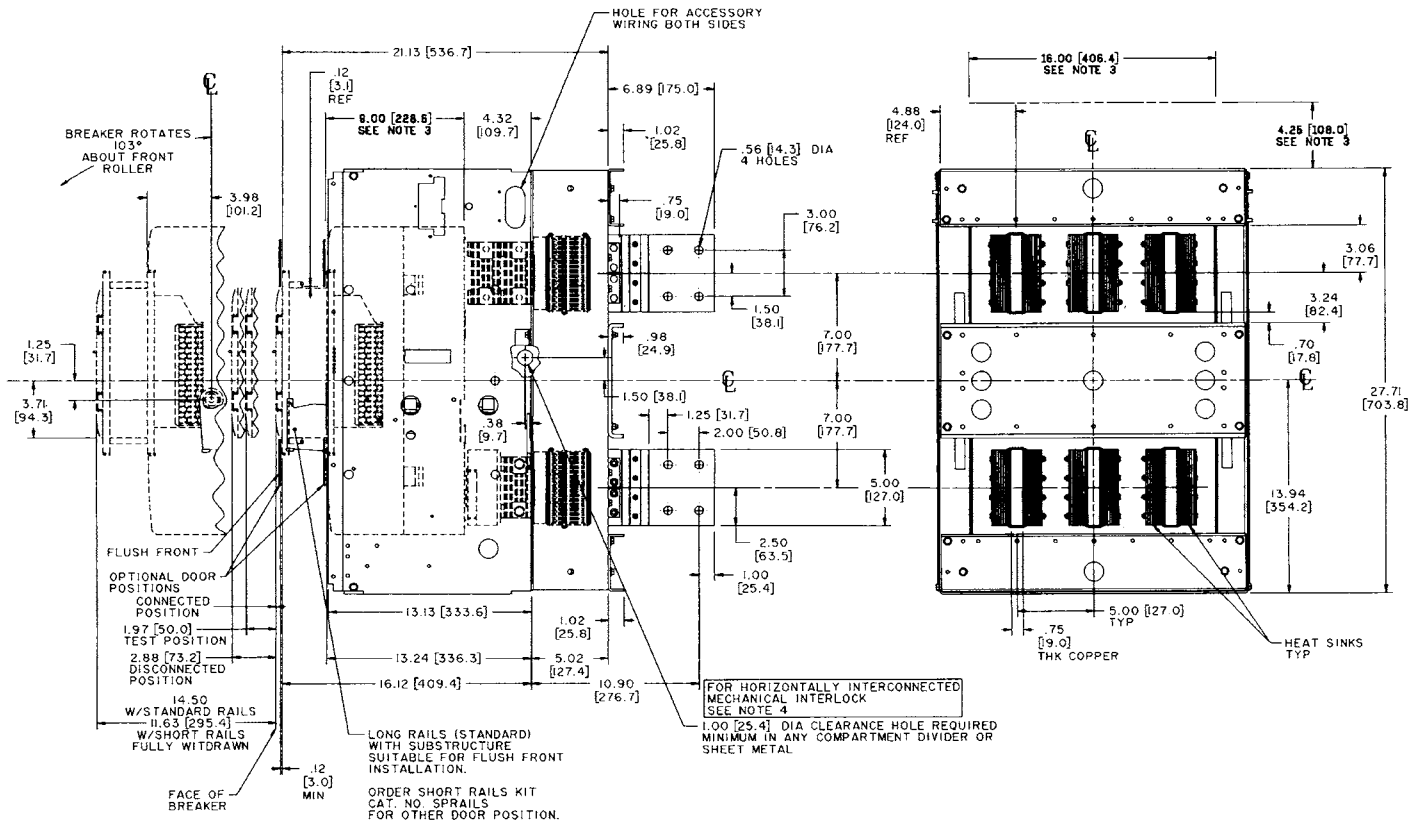

1. All outline dimensions are the same for manually and electrically operated devices.
2. Dimensions in brackets are in [millimeters].
3. 4.25 [108] minimum distance above substructure (8.00 [203.2] from top of circuit breaker) to any metal in an area 9.00 x 16.00 [228.6 x 406.4] due to arc chamber venting.
4. Customer's location for drilling hole for horizontally or vertically interconnected mechanical interlock. See bottom or side view.

Physical Data

Power Break® II 800-2000A Stationary Mechanical Interlock

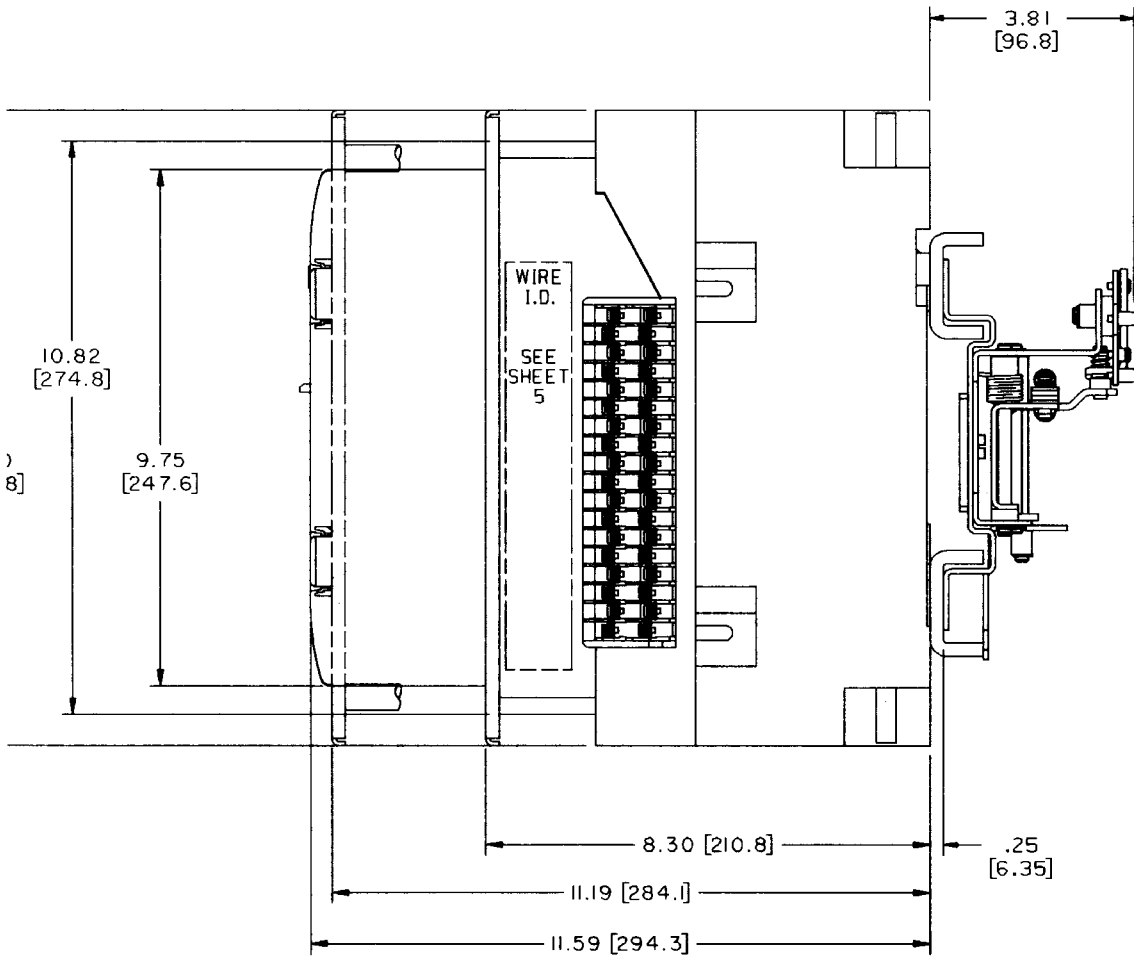

Physical Data

Power Break® II 800-2000A Stationary Mechanical Interlock

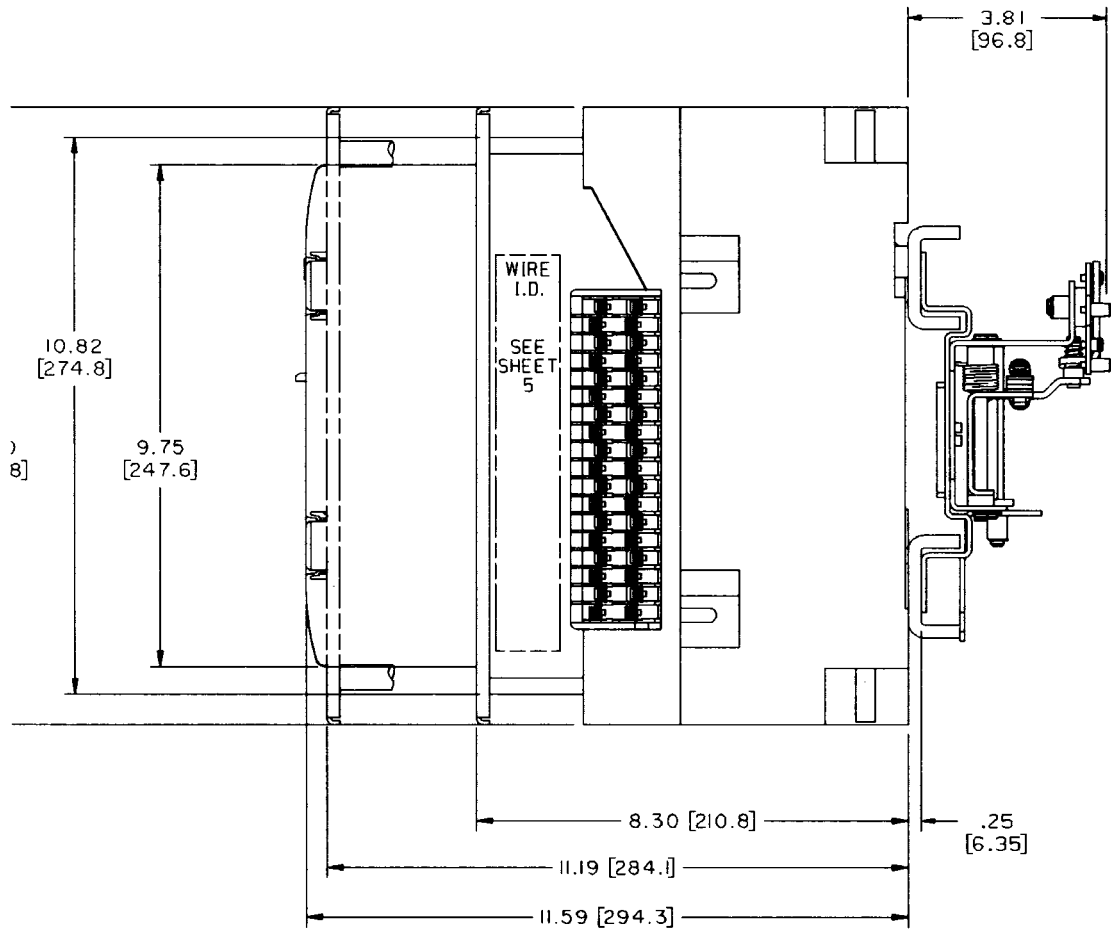

Physical Data

Power Break® II 800-2000A Drawout Mechanical Interlock

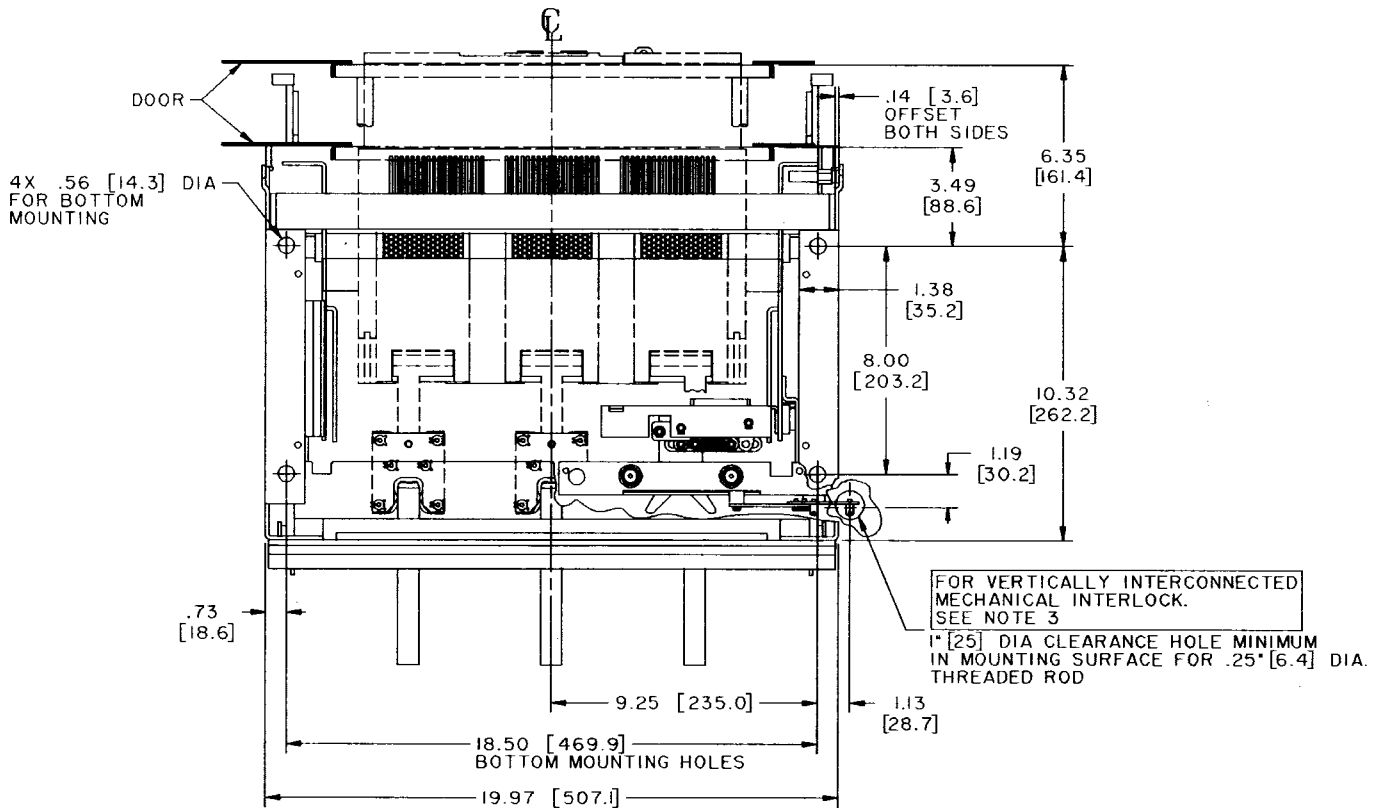
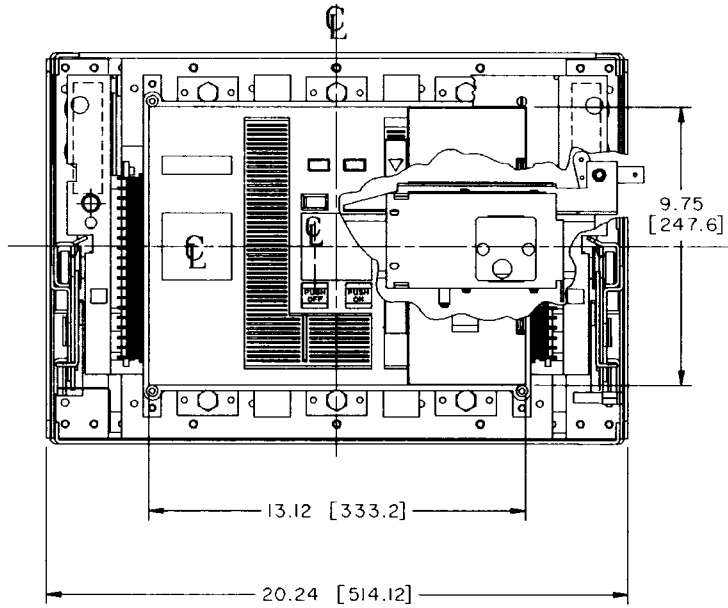

1. All outline dimensions are the same for manually and electrically operated devices.
2. Dimensions in brackets are in [millimeters].
3. Customer's location for drilling hole for horizontally or vertically interconnected mechanical interlock. See bottom or side view.

Physical Data

Power Break® II 800-2000A Drawout Mechanical Interlock

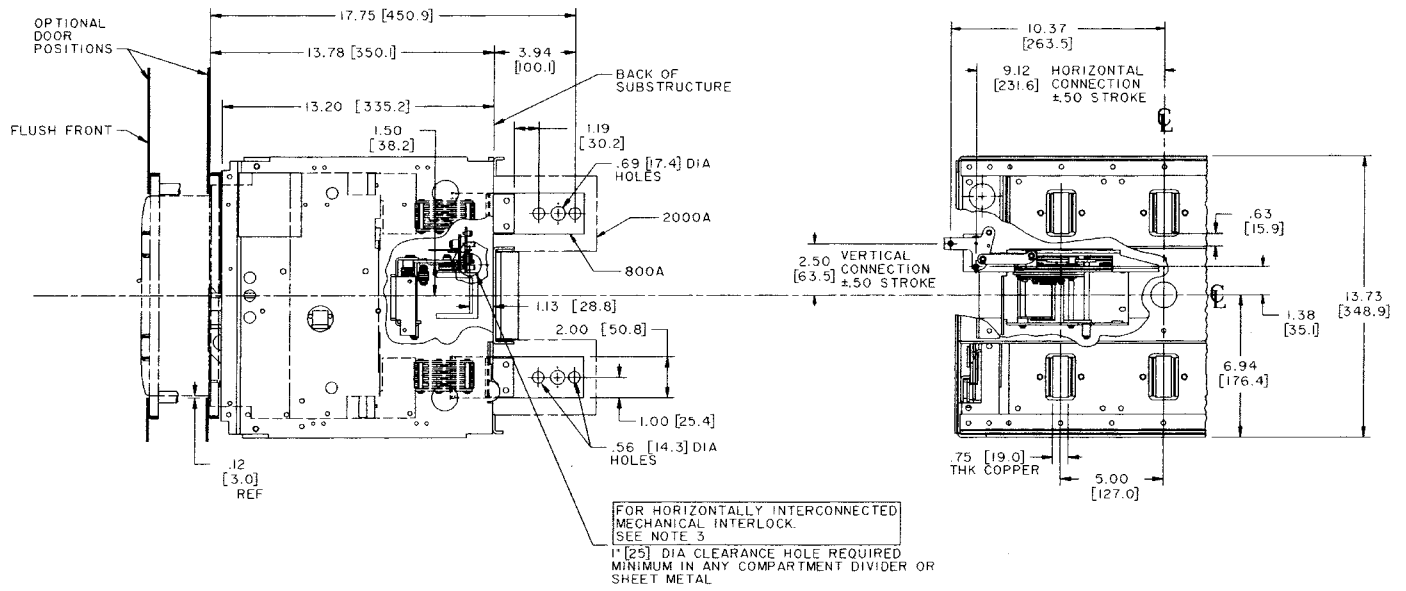

1. All outline dimensions are the same for manually and electrically operated devices.
2. Dimensions in brackets are in [millimeters].
3. Customer's location for drilling hole for horizontally or vertically interconnected mechanical interlock. See bottom or side view.

Physical Data

Power Break® II 2500-3000A Stationary Mechanical Interlock

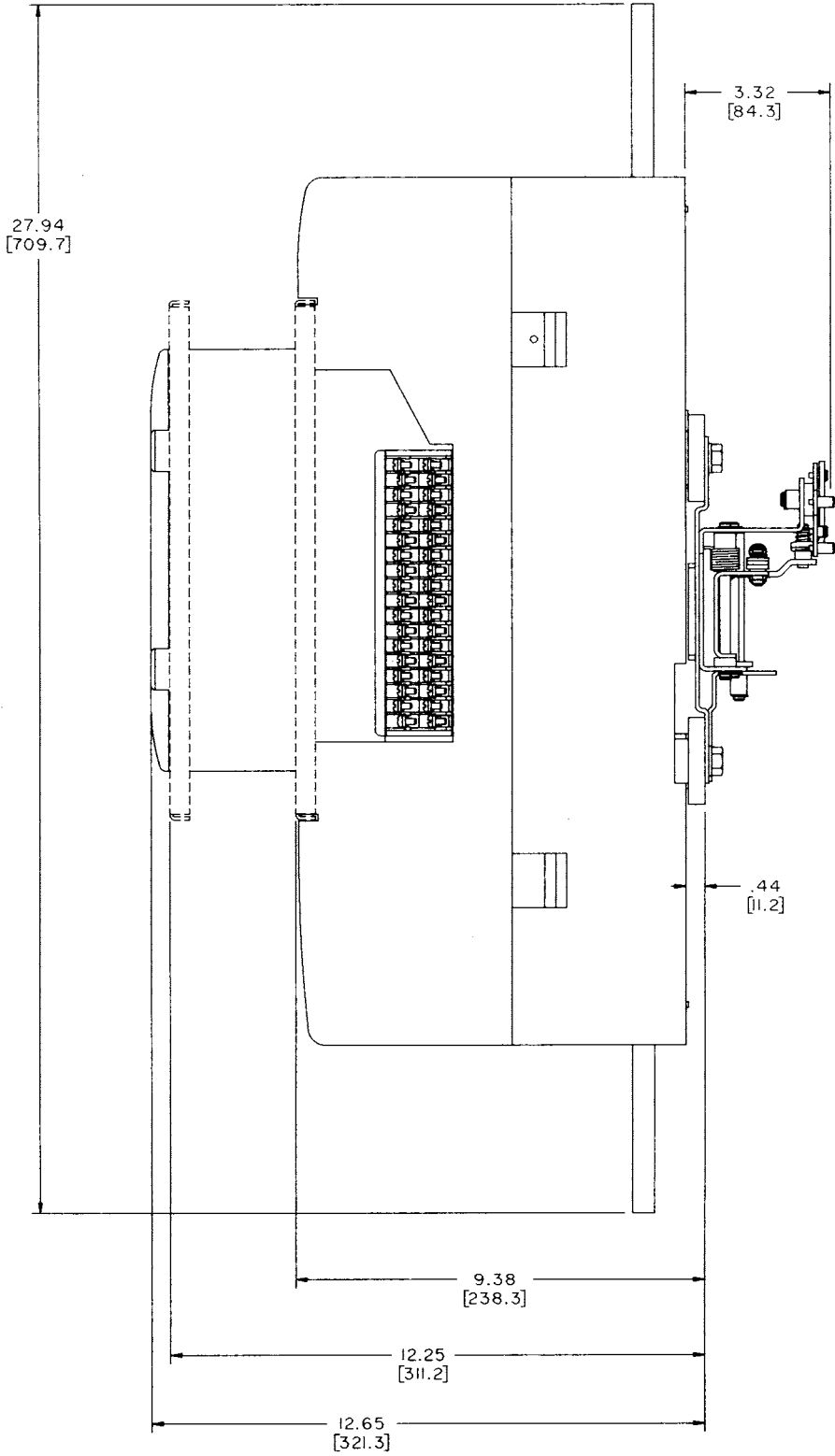

Physical Data

Power Break® II 2500-3000A Stationary Mechanical Interlock

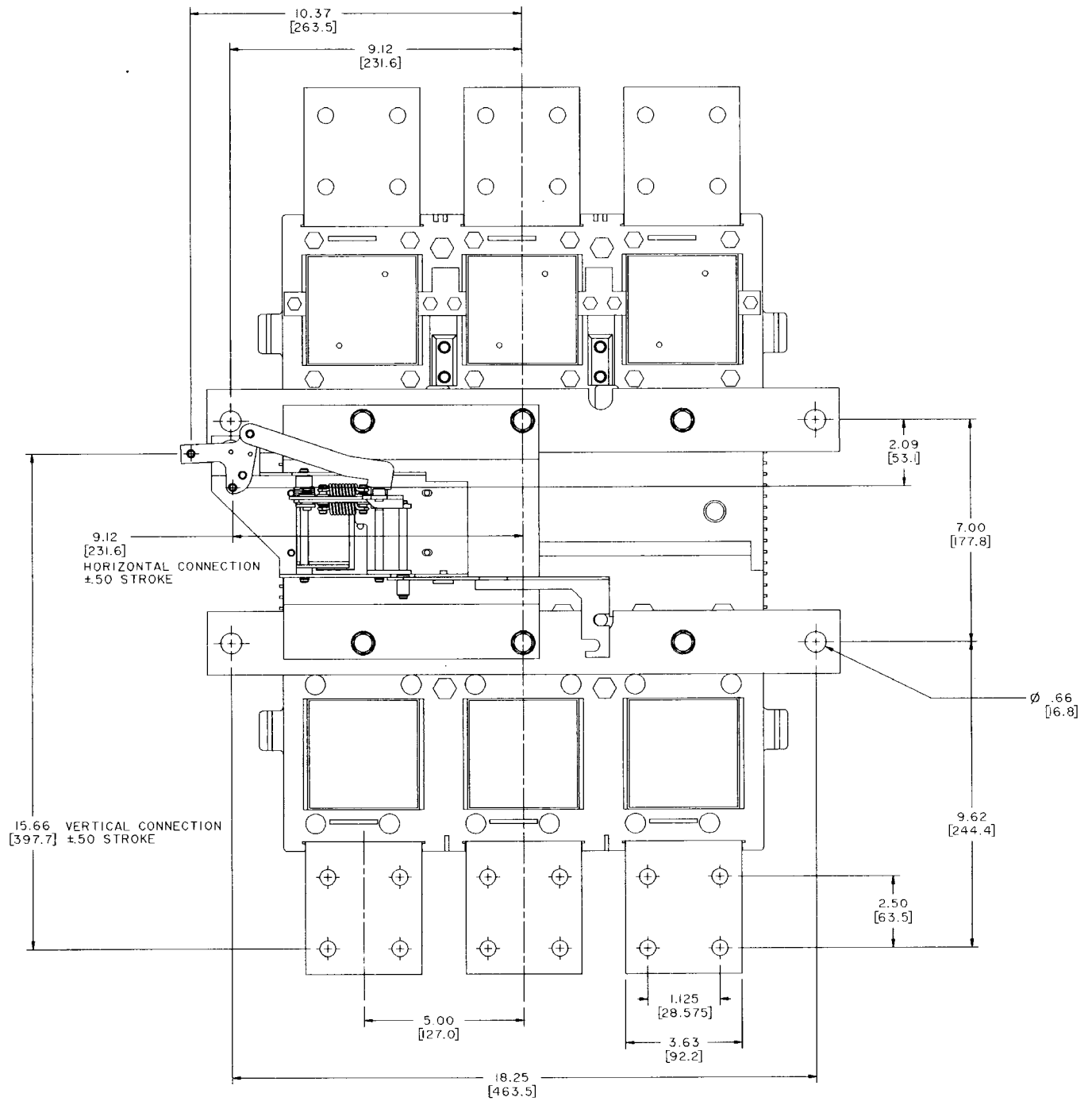

Physical Data

Power Break® II 2500-3000A Drawout Mechanical Interlock

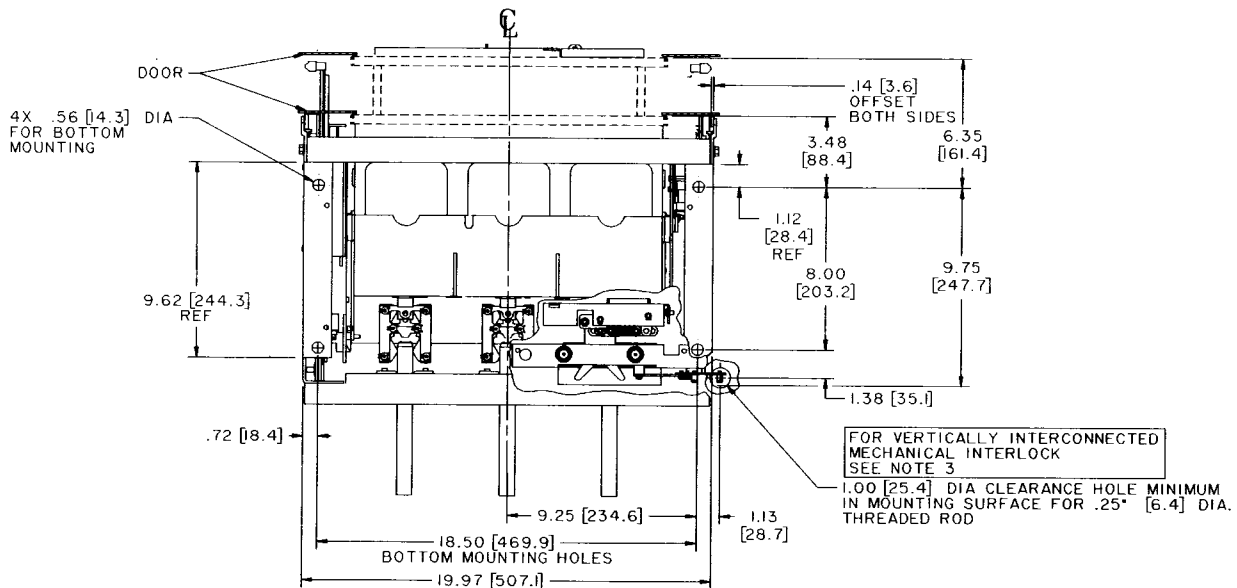
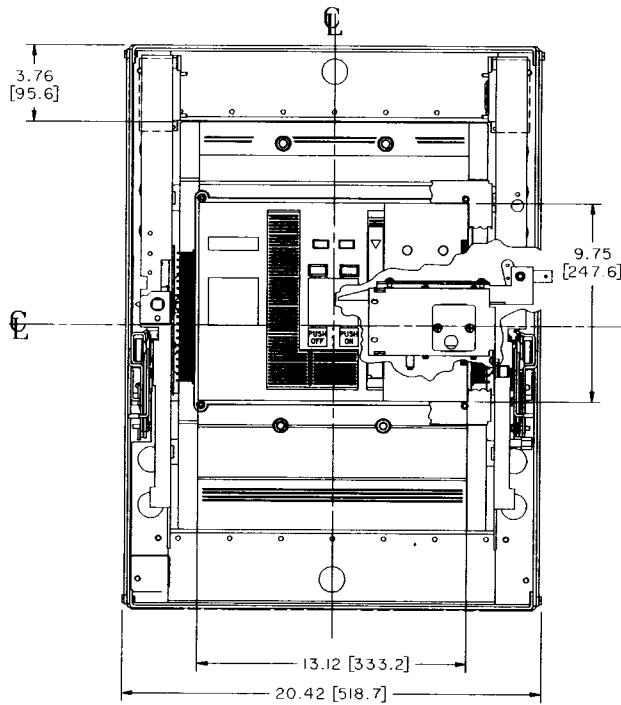

1. All outline dimensions are the same for manually and electrically operated devices.
2. Dimensions in brackets are in [millimeters].
3. Customer's location for drilling hole for horizontally or vertically interconnected mechanical interlock. See bottom or side view.

Physical Data

Power Break® II 2500-3000A Drawout Mechanical Interlock

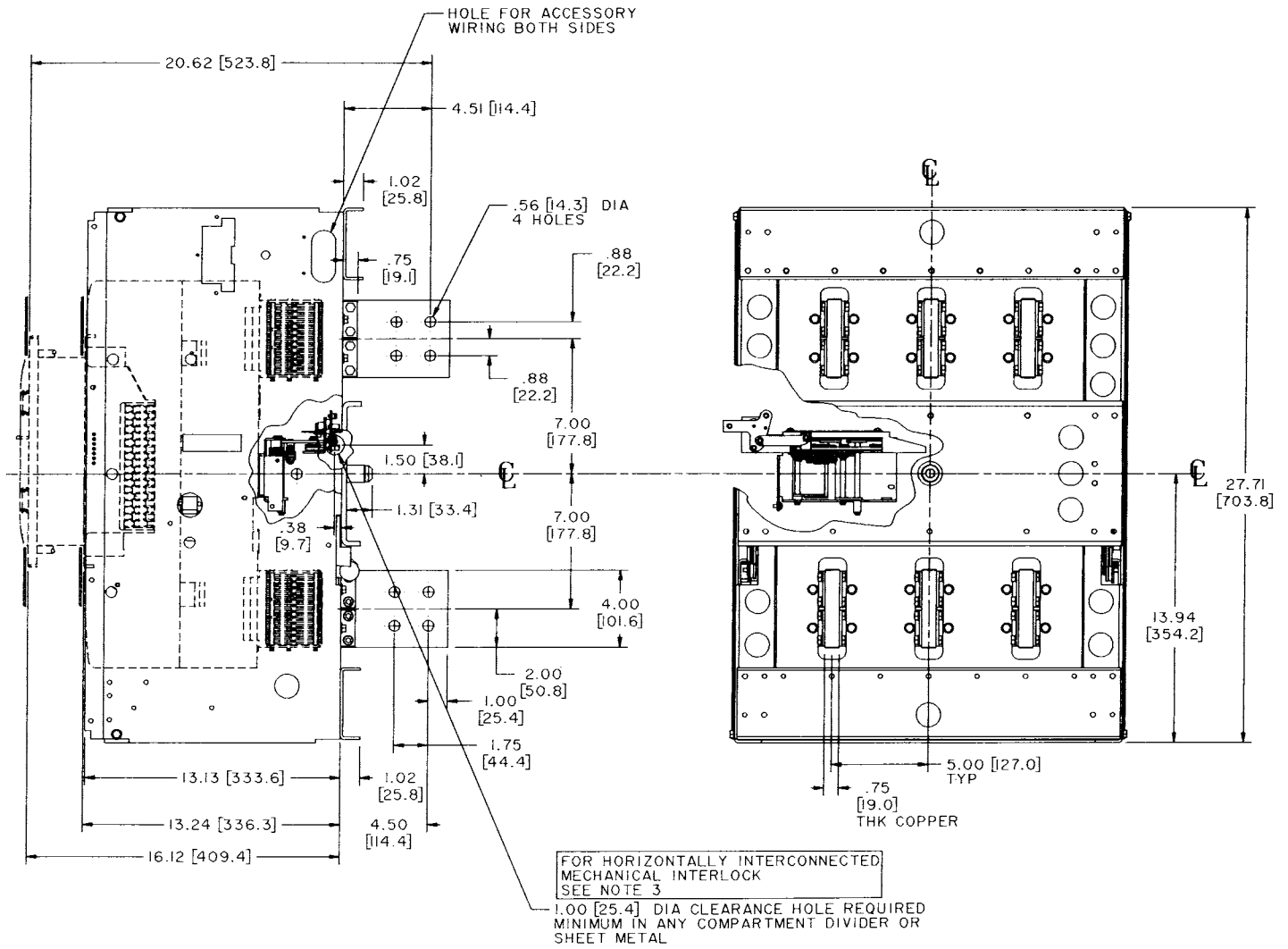

1. All outline dimensions are the same for manually and electrically operated devices.
2. Dimensions in brackets are in [millimeters].
3. Customer's location for drilling hole for horizontally or vertically interconnected mechanical interlock. See bottom or side view.

Physical Data

Power Break® II 4000A Stationary Mechanical Interlock

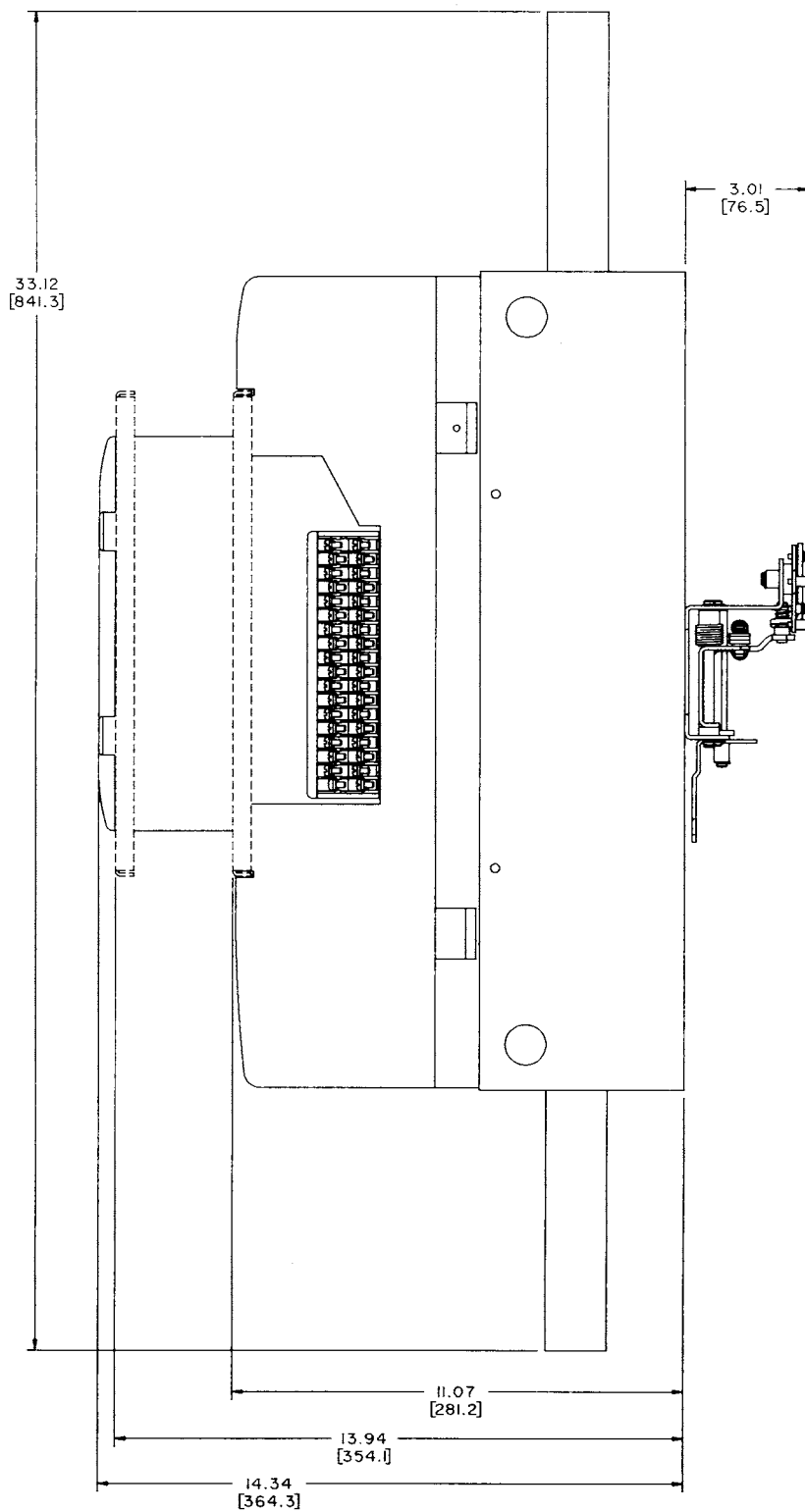

Physical Data

Power Break® II 4000A Stationary Mechanical Interlock

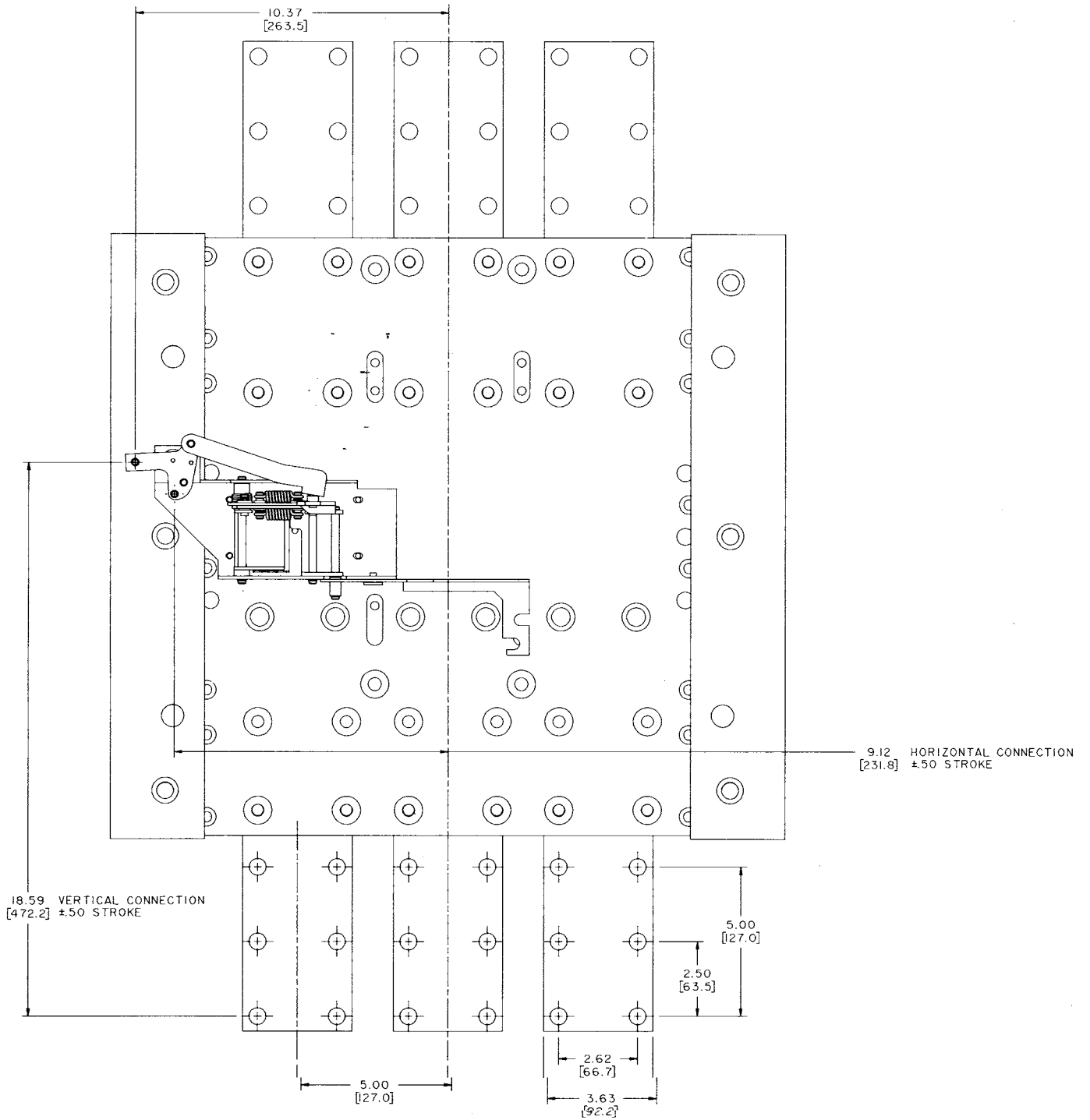

Physical Data

Power Break® II 4000A Drawout Mechanical Interlock

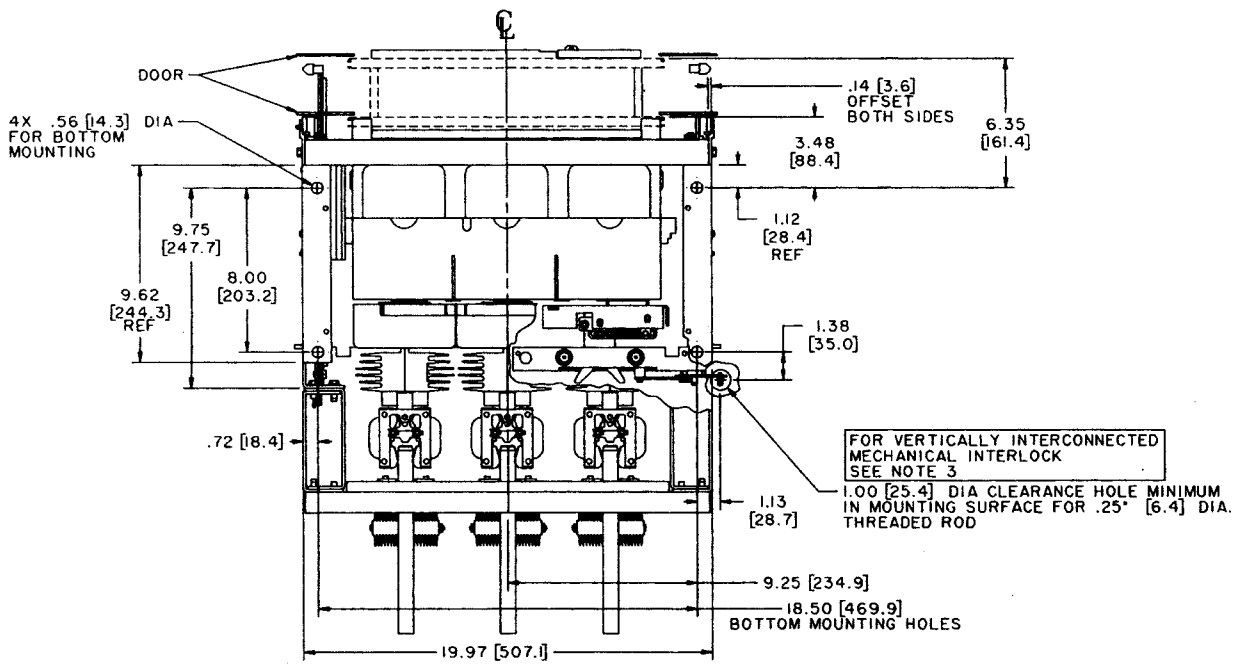
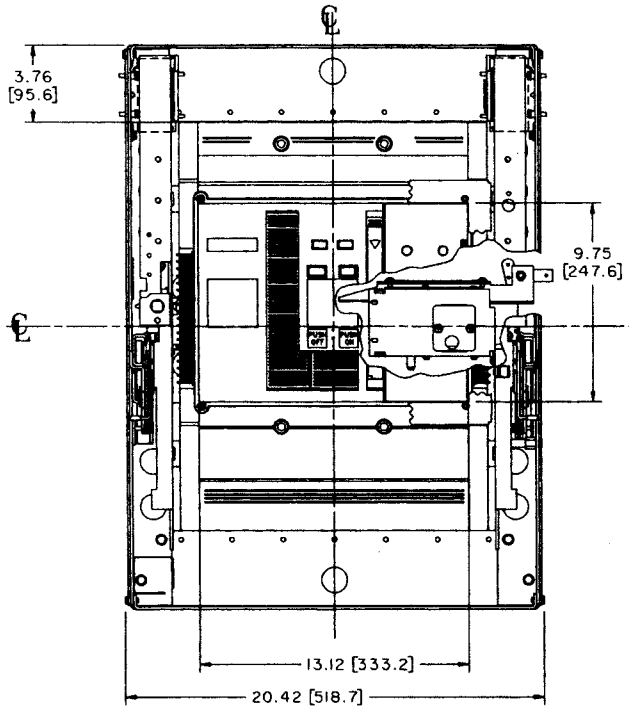

1. All outline dimensions are the same for manually and electrically operated devices.
2. Dimensions in brackets are in [millimeters].
3. Customer's location for drilling hole for horizontally or vertically interconnected mechanical interlock. See bottom or side view.

Physical Data

Power Break® II 4000A Drawout Mechanical Interlock

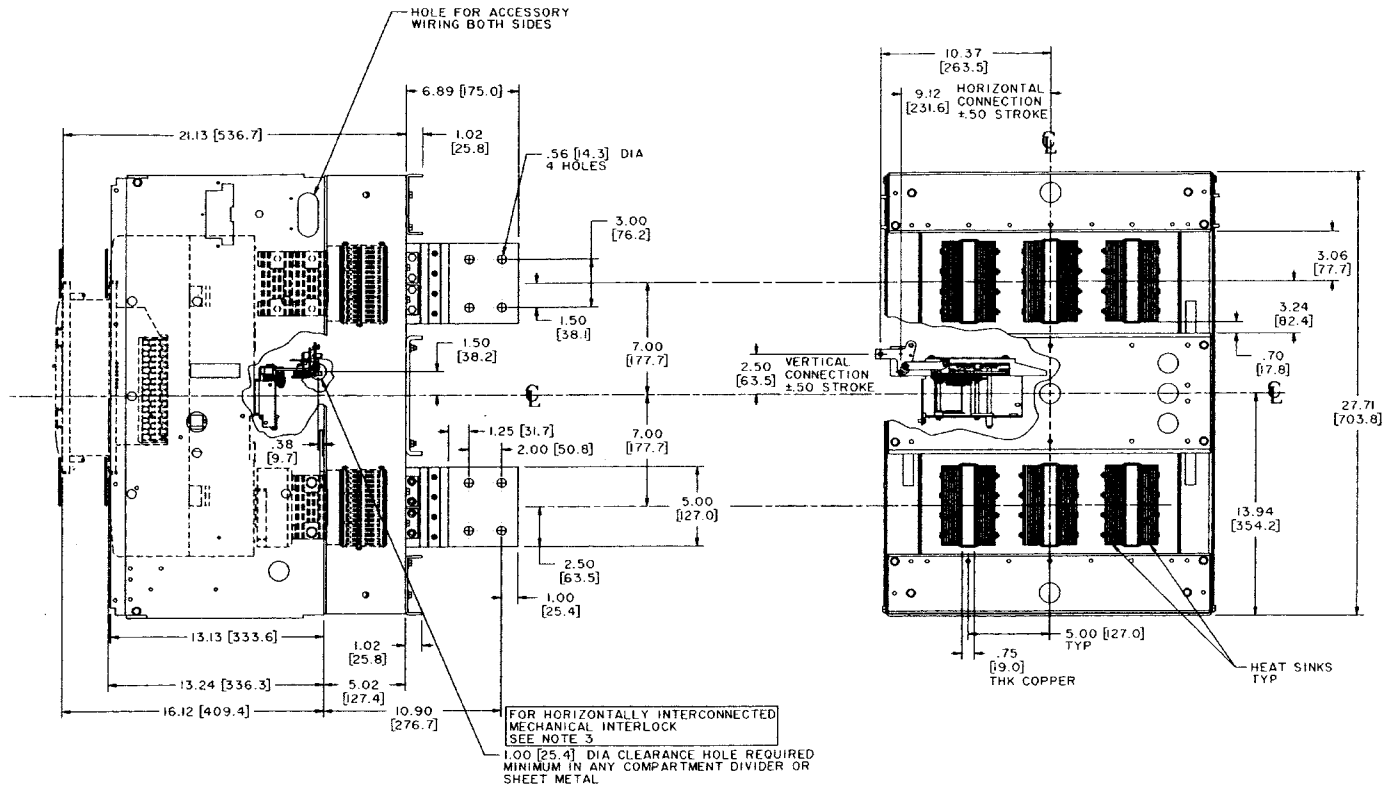

1. All outline dimensions are the same for manually and electrically operated devices.
2. Dimensions in brackets are in [millimeters].
3. Customer's location for drilling hole for horizontally or vertically interconnected mechanical interlock. See bottom or side view.

Physical Data

Power Break® II Information, 2500A-4000A Frames

WRITE ON SPACES FOR SWITCHBOARD
CIRCUIT IDENTIFICATION

AUXILIARY SWITCH	
INTERNAL WIRE COLORS: Red - 'A' Stage, Brown-White - 'B' Stage, White - Common	
When Dielectric Testing be sure all 3 terminals are connected together. Do not apply high voltage between terminals.	
CONTACT RATING: 5 AMP - 240V AC, 10 AMP - 125V AC, 10 AMP - 250V DC	
10054602P1-A	
19 AUX. 11 "A"	1 AUX. 12 "A"
20 AUX. 11 "B"	2 AUX. 12 "B"
21 AUX. 11 COM	3 AUX. 12 COM
22 AUX. 9 "A"	4 AUX. 10 "A"
23 AUX. 9 "B"	5 AUX. 10 "B"
24 AUX. 9 COM	6 AUX. 10 COM
25 AUX. 7 "A"	7 AUX. 8 "A"
26 AUX. 7 "B"	8 AUX. 8 "B"
27 AUX. 7 COM	9 AUX. 8 COM
28 AUX. 5 "A"	10 AUX. 6 "A"
29 AUX. 5 "B"	11 AUX. 6 "B"
30 AUX. 5 COM	12 AUX. 6 COM
31 AUX. 3 "A"	13 AUX. 4 "A"
32 AUX. 3 "B"	14 AUX. 4 "B"
33 AUX. 3 COM	15 AUX. 4 COM
34 AUX. 1 "A"	16 AUX. 2 "A"
35 AUX. 1 "B"	17 AUX. 2 "B"
36 AUX. 1 COM	18 AUX. 2 COM

FAR* ROW NEAR* ROW

LEFT SIDE
TERMINAL BLOCK LABEL

Block "A"

INTERNAL WIRE HARNESS COLOR CODES:	
R= RED	P= PURPLE
W= WHITE	G= GREEN
Y= YELLOW	B= BLACK
N= BROWN	L= BLUE
10054602P1-B	
18 ELECT. OPER.+ R	36 ELECT. OPER.- B
17 RMT. CHG.+ W	35 RMT. CHG.- L
16 RMT. CLS.+ Y	34 RMT. CLS.- N
15 B.A. ONLY COM Y	33 CHG. IND. G
14 B.A. ONLY N.O. N	32 SHUNT TRIP B
13 B.A. ONLY N.C. P	31 SHUNT TRIP B
12 B.A. LOCKOUT COM W	30 U.V.R. L
11 B.A. LOCKOUT N.O. R	29 U.V.R. L
10 B.A. LOCKOUT N.C. B	28
9	27
8	26 ZSI INPUT- W
7 COMMNET- G	25 ZSI INPUT+ G
6 COMMNET+ Y	24 ZSI OUTPUT- W
5 C Ø VOLTS R	23 ZSI OUTPUT+ R
4 B Ø VOLTS W	22 D/O SWITCH W
3 A Ø VOLTS L	21 D/O SWITCH L
2 24VOLTS DC- B	20 -# TAP B
1 24VOLTS DC+ R	19 -# COM. W

NEAR* ROW FAR* ROW

RIGHT SIDE
TERMINAL BLOCK LABEL

Block "B"

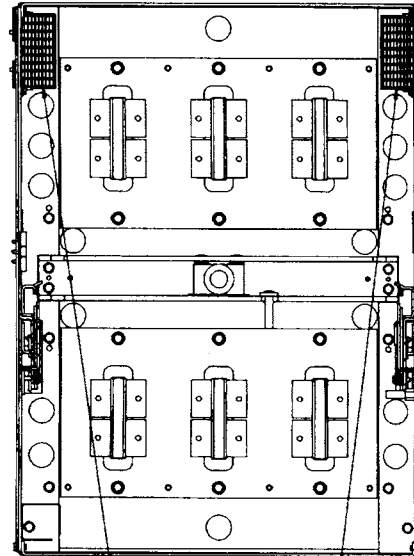

SECONDARY DISCONNECT PLUG
(DEDICATED POSITIONS)

LEFT SIDE RIGHT SIDE
NOTE: ALL WIRES ON LEFT = AUX. SWITCH WIRES.
ALL WIRES ON RIGHT = ALL OTHER WIRING.
#S CORRESPOND TO WIRE CHART
I.E. #31, 32 RIGHT = SHUNT TRIP

Wire Chart

*Screw terminal position relative to front of circuit breaker
Note: Wire range #18 thru #12 solid or stranded copper wire. Torque: 9lb-in

Physical Data

Power Break® II Information, 2500A-4000A Frames

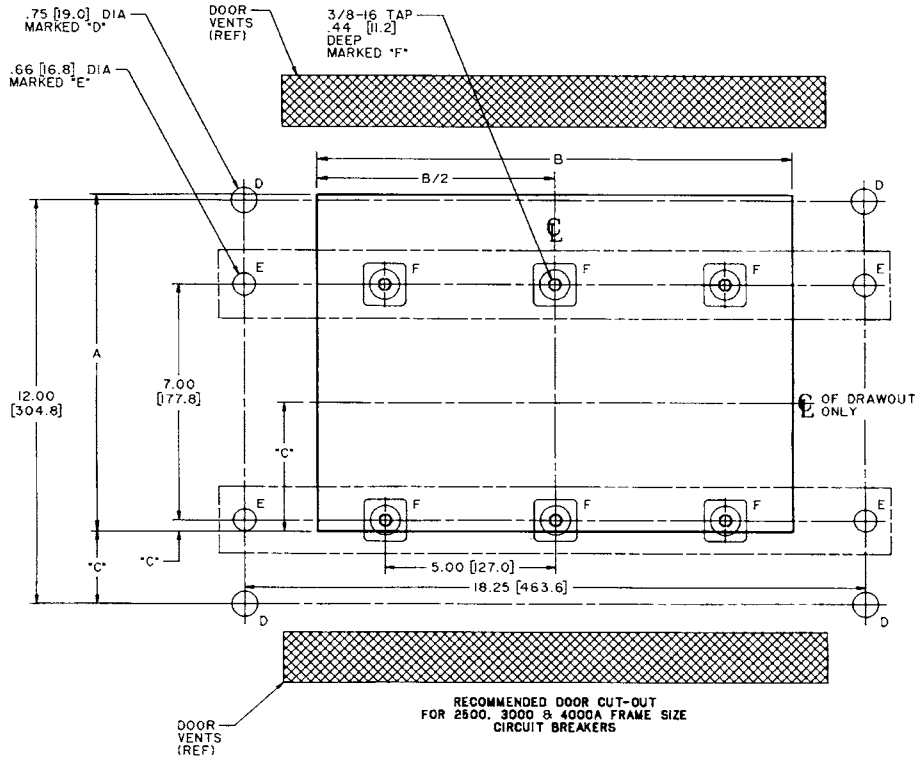

Table 1

Frame Rating	Breaker Type	Weight		Minimum Compartment Volume	Minimum Door Ventilation	Standard Door Cut-Out			Optional Door Cut-Out								
		Breaker	Drawout Substructure			A	B	C	A	B	C						
2500A	Back Connected	167 lbs. [76 kg]*	N/A	13,950 cu. in. [228,600 cu. cm]	160 sq. in. [1,032 sq. cm] Total 80 sq. in. [516 sq. cm] Top 80 sq. in. [516 sq. cm] Bottom	10 [254]	14 [356]	.34 [8,6]	9.83 [249,7]	13.38 [339,9]	255 [6,4]						
	Front Connected	178 lbs. [81 kg]*															
3000A	Back Connected	216 lbs. [98.3 kg]*		20,832 cu. in. [341,375 cu. cm]	270 sq. in. [1,742 sq. cm] Total 135 sq. in. [871 sq. cm] Top 135 sq. in. [871 sq. cm] Bottom							Trim plate Required	2.17 [55,1]	Flush Front or Non-hinged Door Construction Trim Plate may be omitted			
	Front Connected	179 lbs. 81.4 kg)*															
4000A	Front Connected	320 lbs. [145.6 kg]		25,143 cu. in. [412,020 cu. cm]	270 sq. in. [1,742 sq. cm] Total 135 sq. in. [871 sq. cm] Top 135 sq. in. [871 sq. cm] Bottom										Trim plate Required	2.17 [55,1]	2.255 [57,28]
2500A	Drawout Mounted	232 lbs. [105.6 kg]*		111 lbs. [50.5 kg]*	10,991 cu. in. [180,108 cu. cm]												
3000A		233 lbs. [106 kg]*	111 lbs. [50.5 kg]*	10,991 cu. in. [180,108 cu. cm]	246 sq. in. [1,587 sq. cm] Total 123 sq. in. [793,5 sq. cm] Top 123 sq. in. [793,5 sq. cm] Bottom												
4000A		295 lbs. [134.2 kg]*	167 lbs. [76 kg]*	15,138 cu. in. [248,074 cu. cm]	246 sq. in. [1,587 sq. cm] Total 123 sq. in. [793,5 sq. cm] Top 123 sq. in. [793,5 sq. cm] Bottom												

N/A = Not Applicable

* Add 9 lbs. [4.1 kg] for electrical operator

1. Dimensions in brackets are [metric].
2. Busbars or cables should be sized per UL891 dead-front switchboards standard.
3. "D" Dia. = 4000 Amp front connected breaker mounting holes.
4. "E" Dia. = 2500A and 3000A front connected breaker mounting holes.
5. "F" Dia. = 2500A and 3000A back connected breaker mounting inserts.

Physical Data

Power Break® II 800-Amp T-Studs

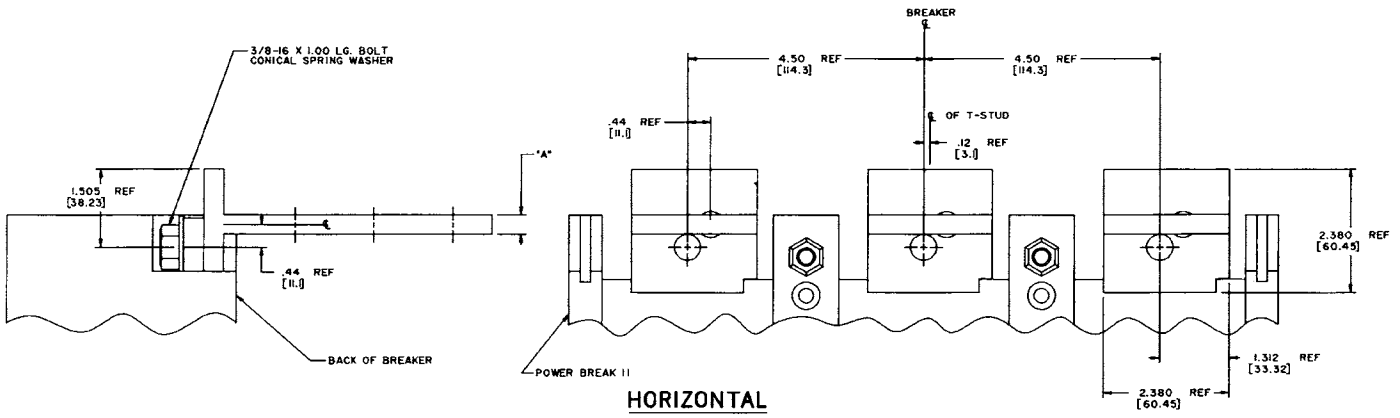

Catalog No.	Material	Finish	"A"
SP08FCA	AL	Tin	78 + .01 - .02 [19,8 + 0,3 - 0,5]
SP08FCC	AL	Tin	375 ± .005 [9,53 ± 0,13]

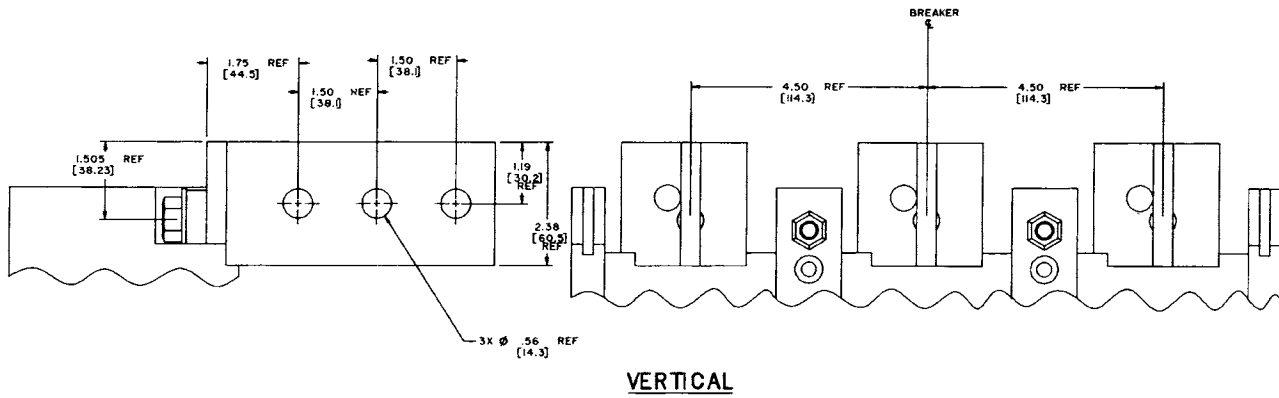

1. T-studs may be mounted to either the line or load straps, and oriented horizontally or vertically as shown.
2. Dimensions in brackets are in (millimeters).

Physical Data

Power Break® II 1600-2000 Amp T-Studs

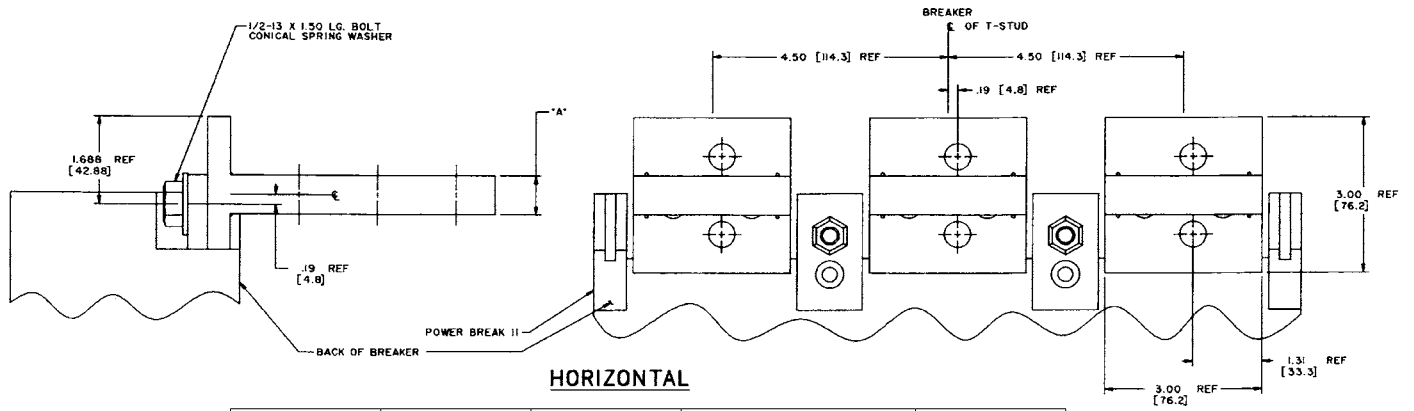

Catalog No.	Material	Finish	"A"	Breaker Amps
SP20FCA	AL	Tin	$78 \begin{matrix} +.010 \\ -.020 \end{matrix}$ $[19,8 \begin{matrix} +0,25 \\ -0,51 \end{matrix}]$	1600A-2000A
SP20FCC	CU	Tin	$750 \pm 005 [19.05 \pm 13]$	1600A-2000A

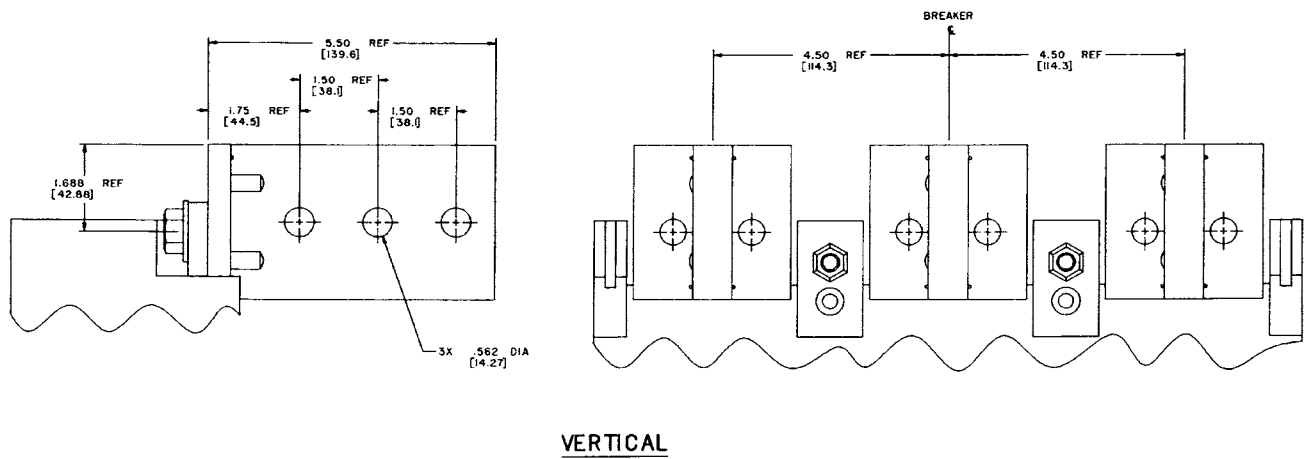

1. T-studs may be mounted to either the line or load straps, and oriented horizontally or vertically as shown.
2. Dimensions in brackets are in [millimeters].

Physical Data

Power Break® II 2000, 2500, 3000-Amp T-Studs

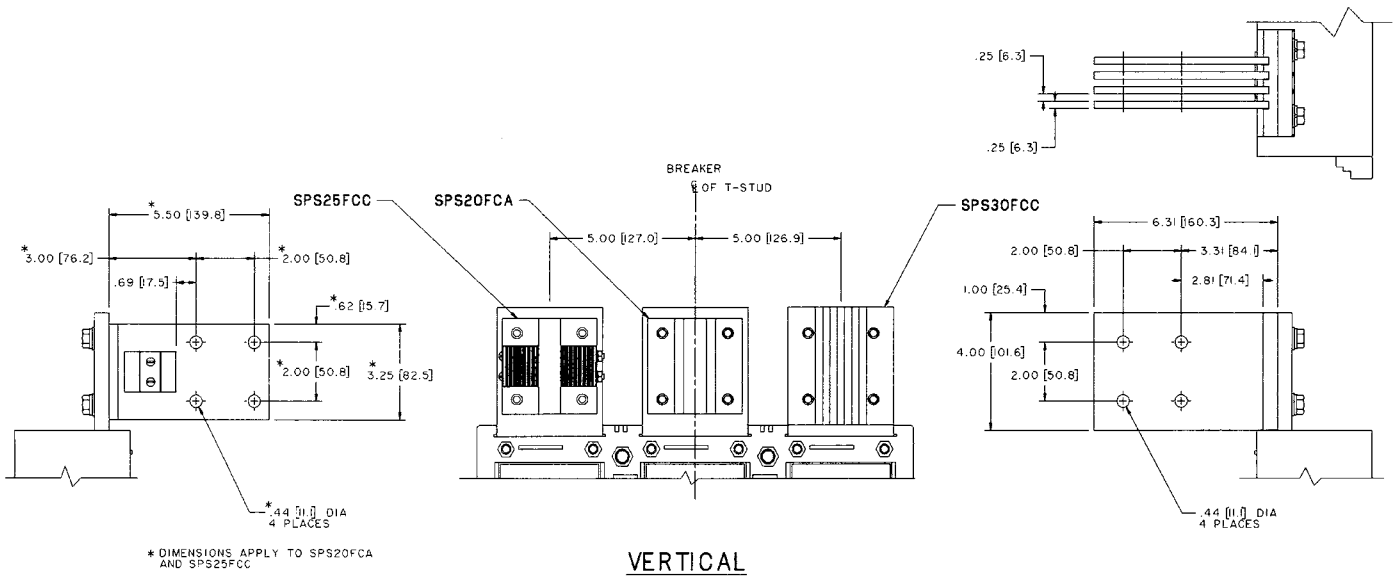
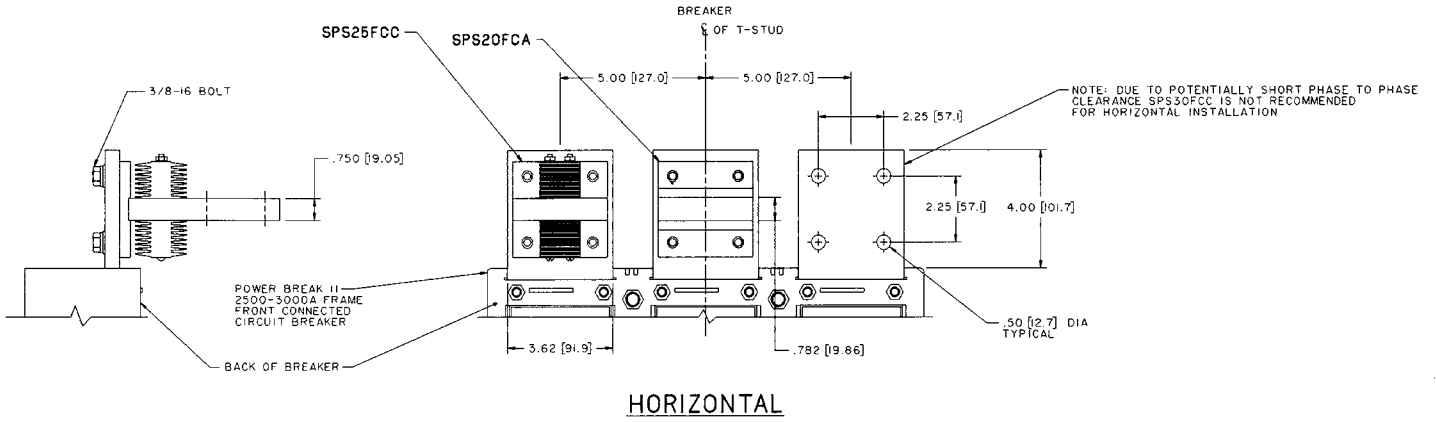

Physical Data

Power Break® II 4000-Amp T-Studs

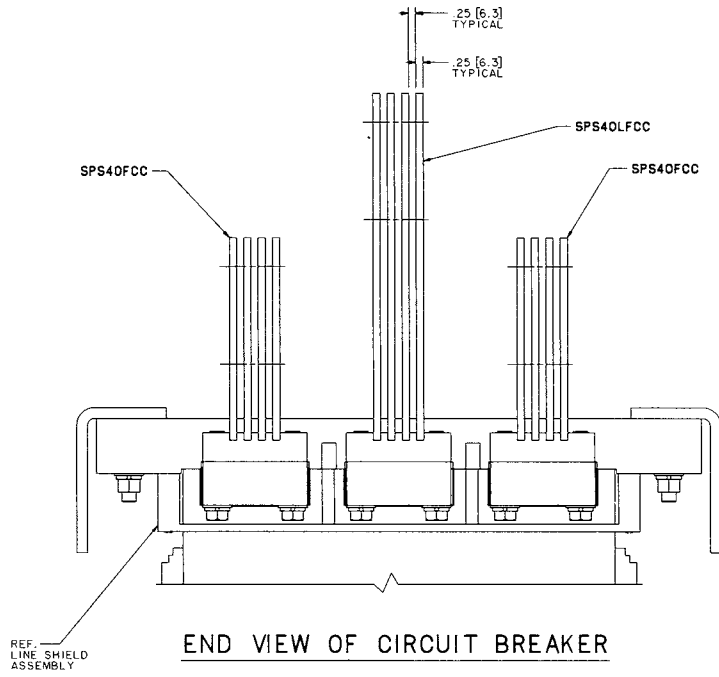
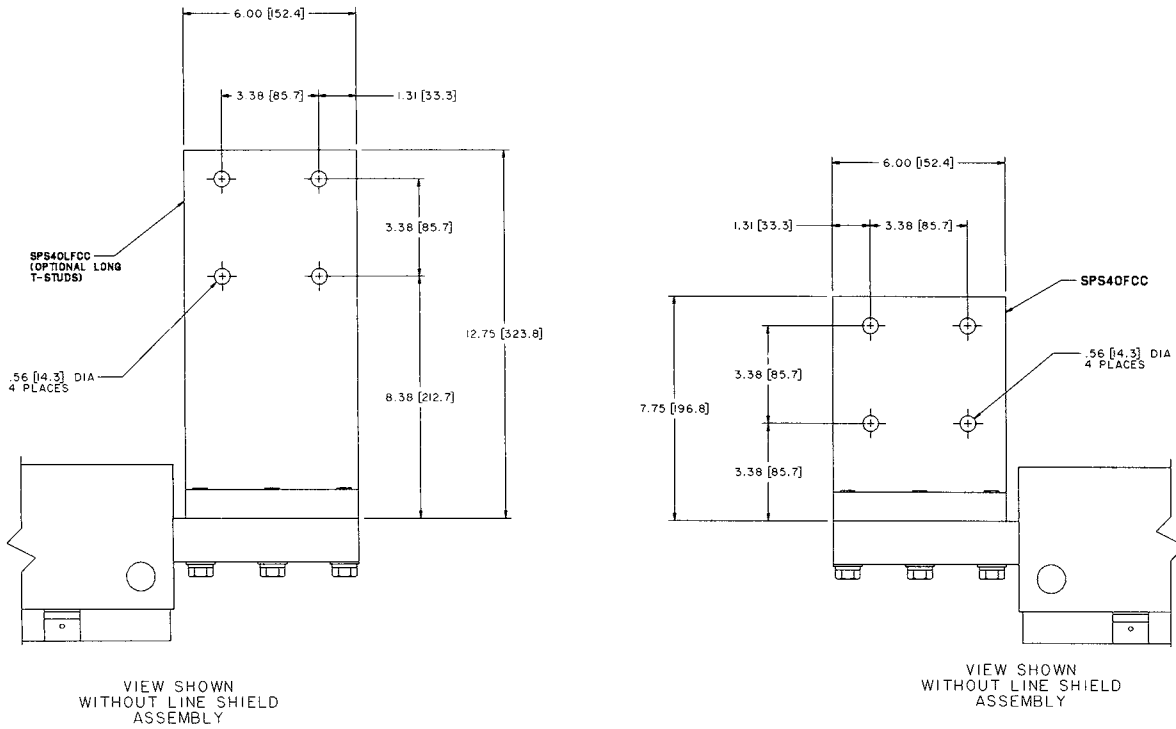

END VIEW OF CIRCUIT BREAKER

1. SPS40FCC may be used on all poles or alternated with SPS40LFCC as shown.

Physical Data

Power Break® II 2000-2500-Amp T-Studs, Back Connected

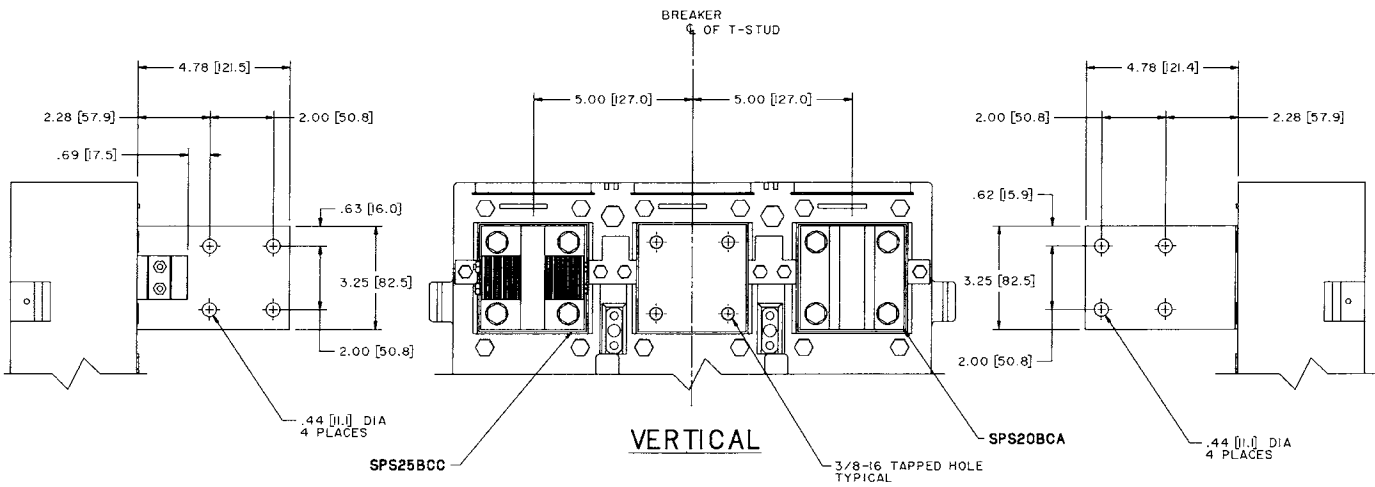
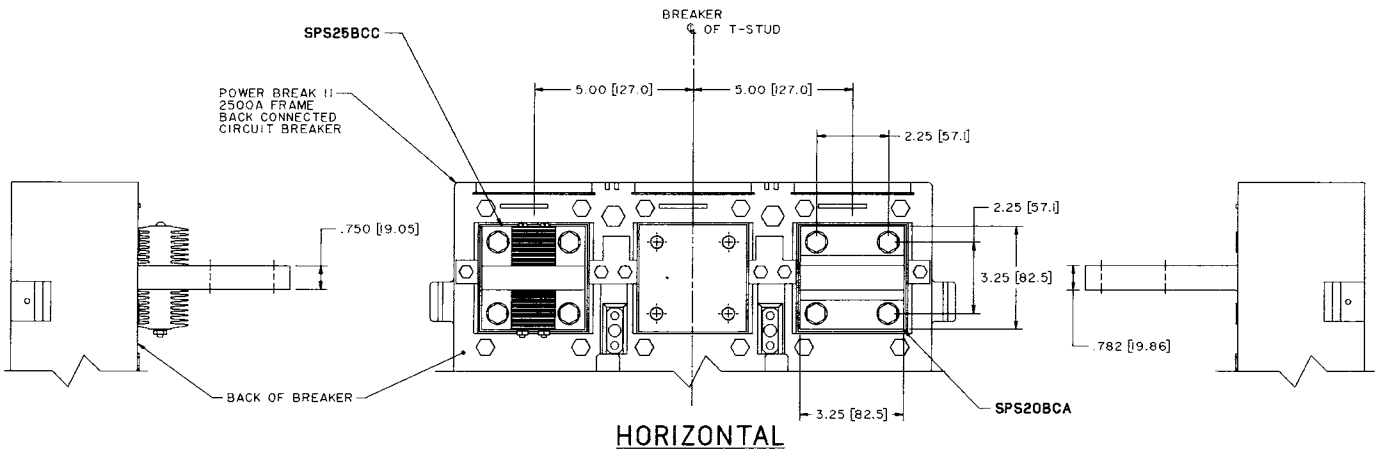

Physical Data

Power Break® II TPLUGA08 On 800 Amps

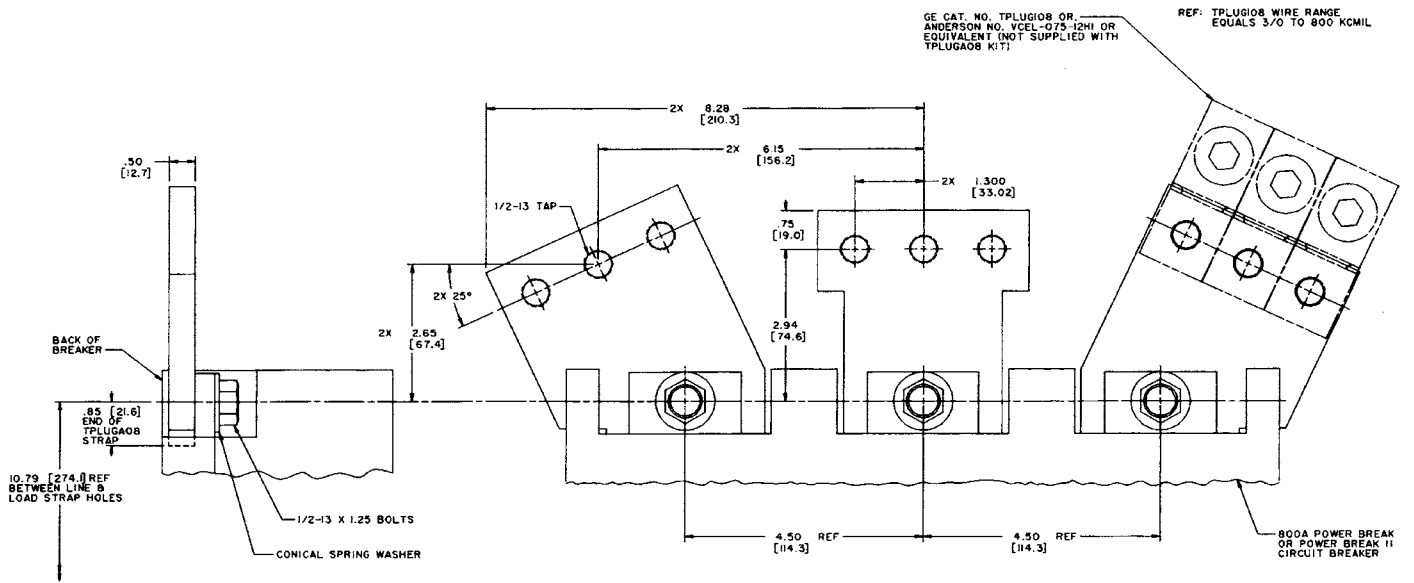

1. Dimensions in brackets are [metric].

Physical Data

Power Break® II TPLUGA16 On 1600 Amps

T-STUDS ACCEPT UP TO SIX LUGS:
 GE CAT. NO. TPLUG108 OR
 ANDERSON NO. VCEL-075-12H1 OR
 EQUIVALENT (NOT SUPPLIED WITH TPLUGA16 KIT)

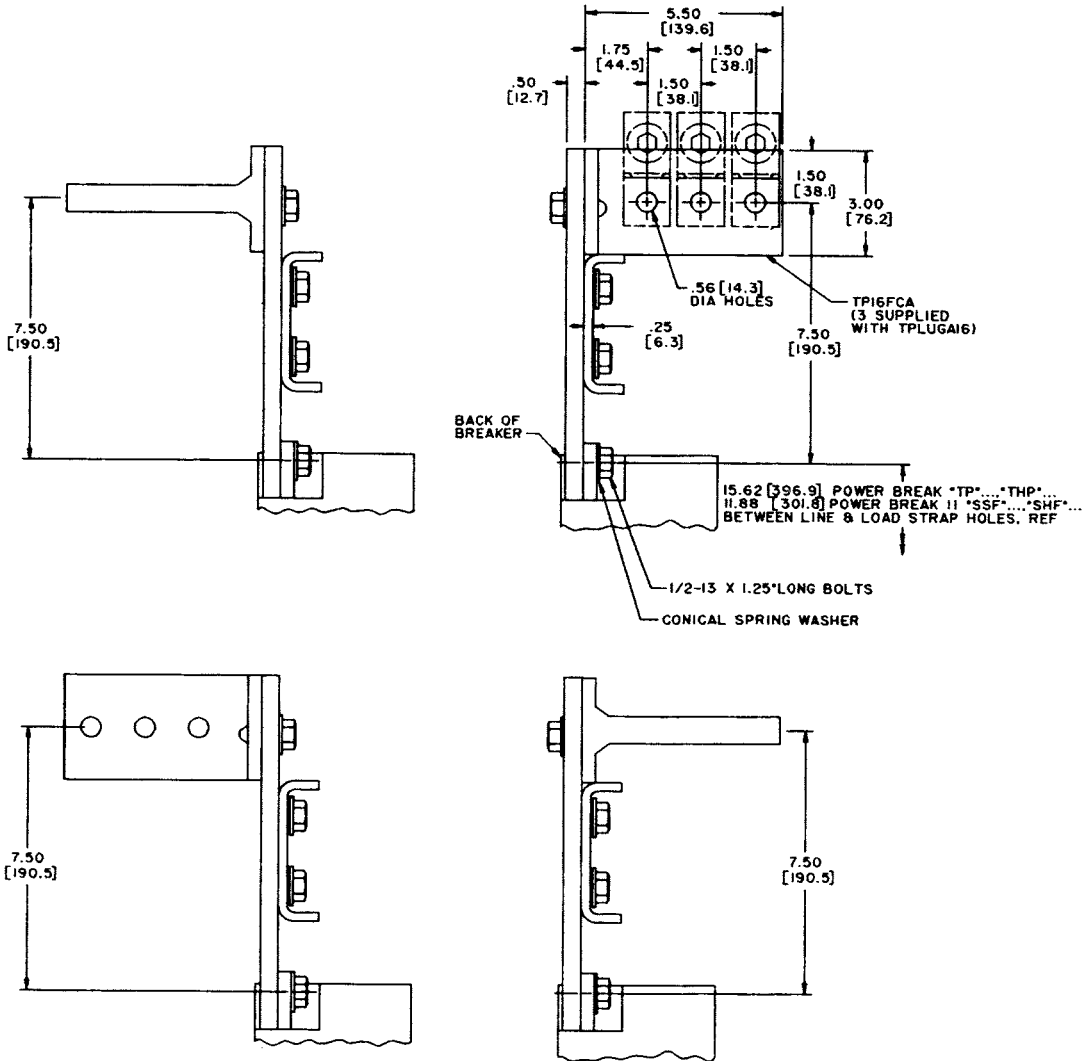

1. TPLUGA 16 kit fits on line or load side of all 1600A Power Break or Power Break II circuit breakers.
2. Dimensions in brackets are in (millimeters).

Physical Data

Power Break® II TPLUGA16 On 1600 Amps

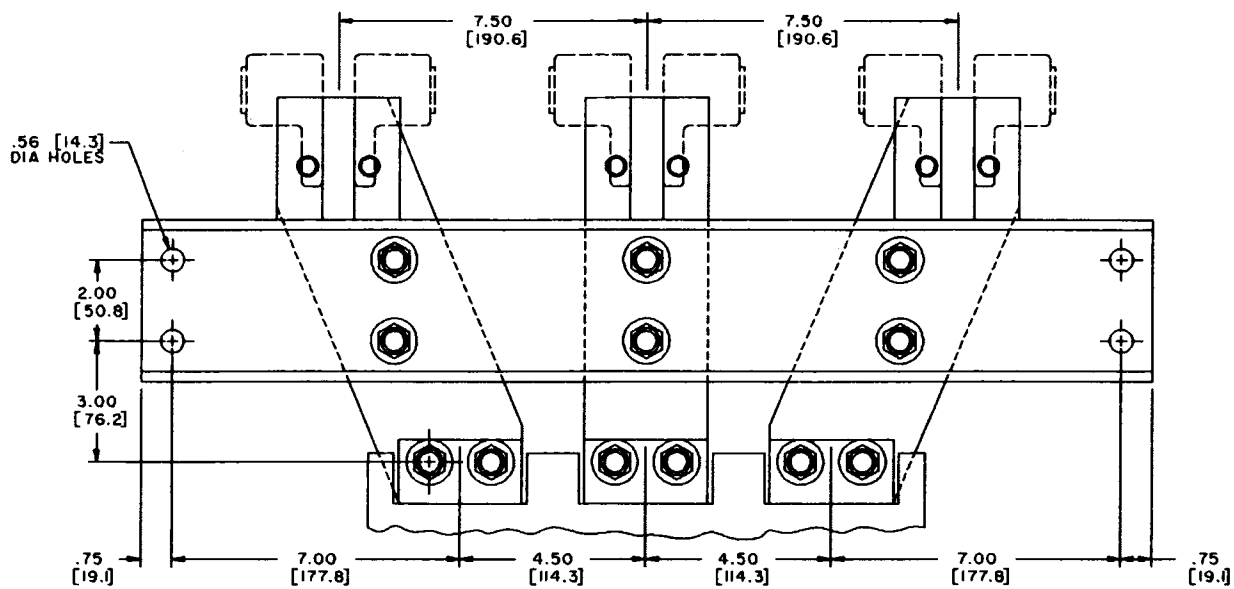

1. TPLUGA 16 kit fits on line or load side of all 1600A Power Break or Power Break II circuit breakers.
2. Dimensions in brackets are in [millimeters].

Physical Data

Power Break® II SPLUGA20 On 2000 Amps

T-STUDS ACCEPT UP TO SIX LUGS:
 GE CAT. NO. TPLUGI08 OR
 ANDERSON NO. VCEL-075-12HI OR
 EQUIVALENT (NOT SUPPLIED WITH SPLUGA20 KIT)

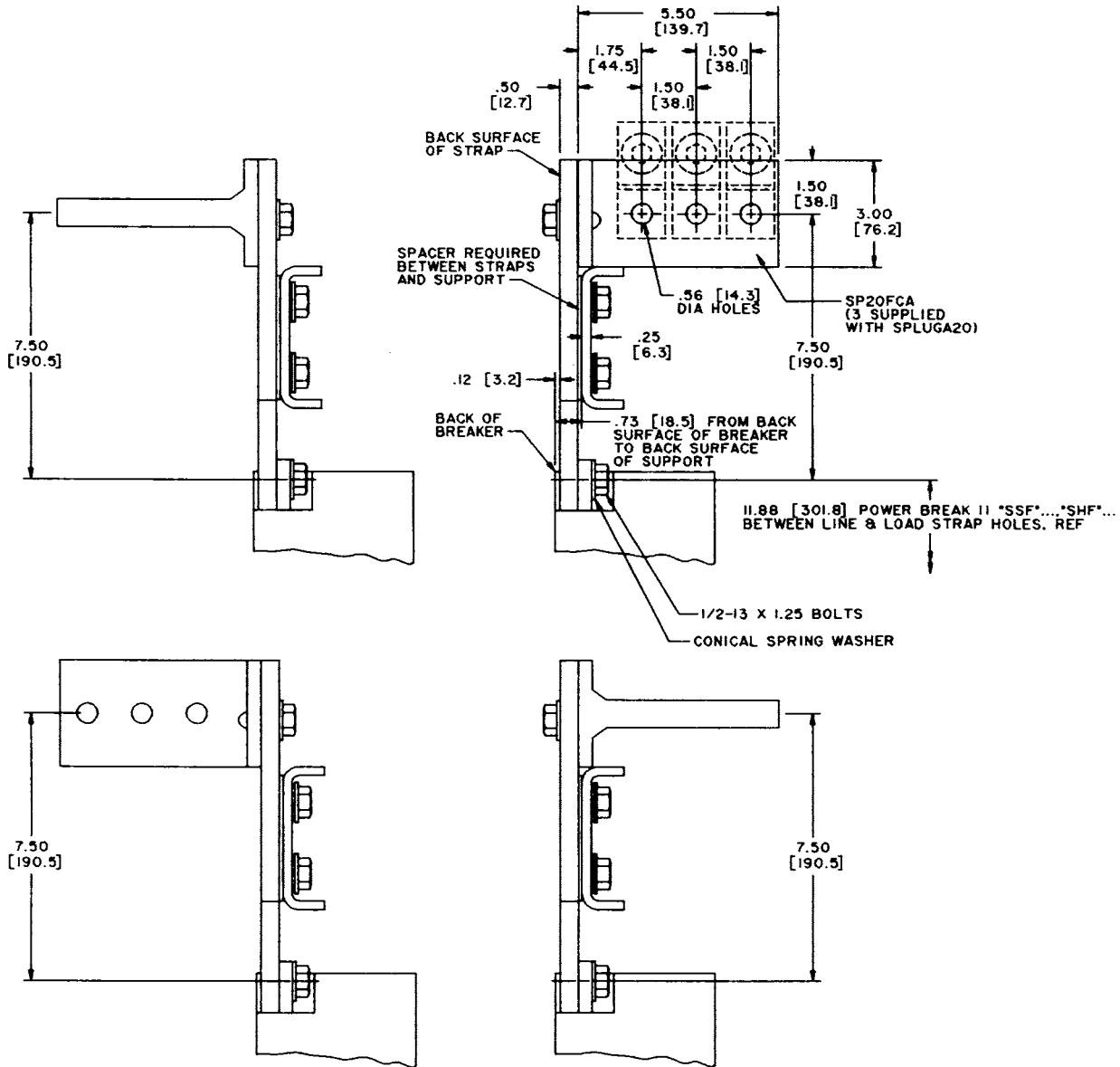

1. SPLUGA20 kit fit on line or load side of all 2000A Power Break II circuit breakers. Does not fit on original Power Break 2000A circuit breaker.

Physical Data

Power Break® II SPLUGA20 On 2000 Amps

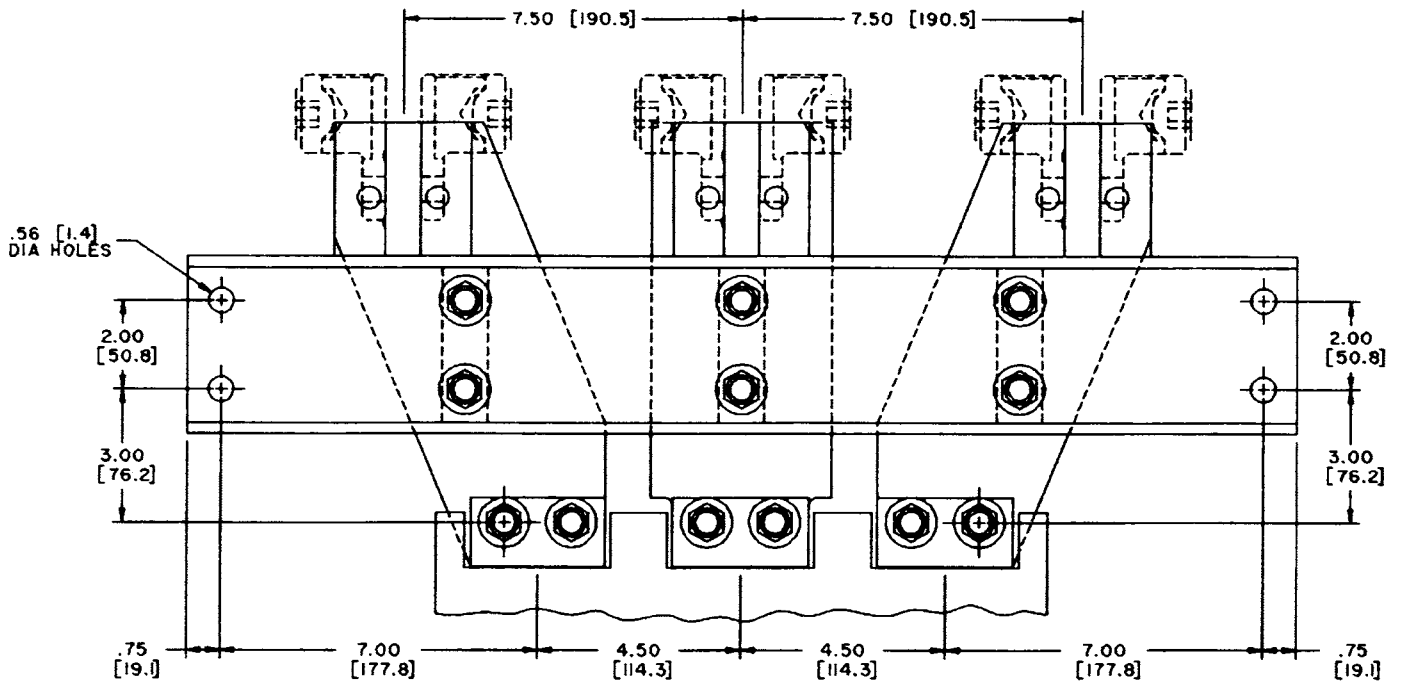

1. SPLUGA20 kit fit on line or load side of all 2000A Power Break II circuit breakers. Does not fit on original Power Break 2000A circuit breaker.

Physical Data

Power Break® II Lug Kits For 2500A Frame

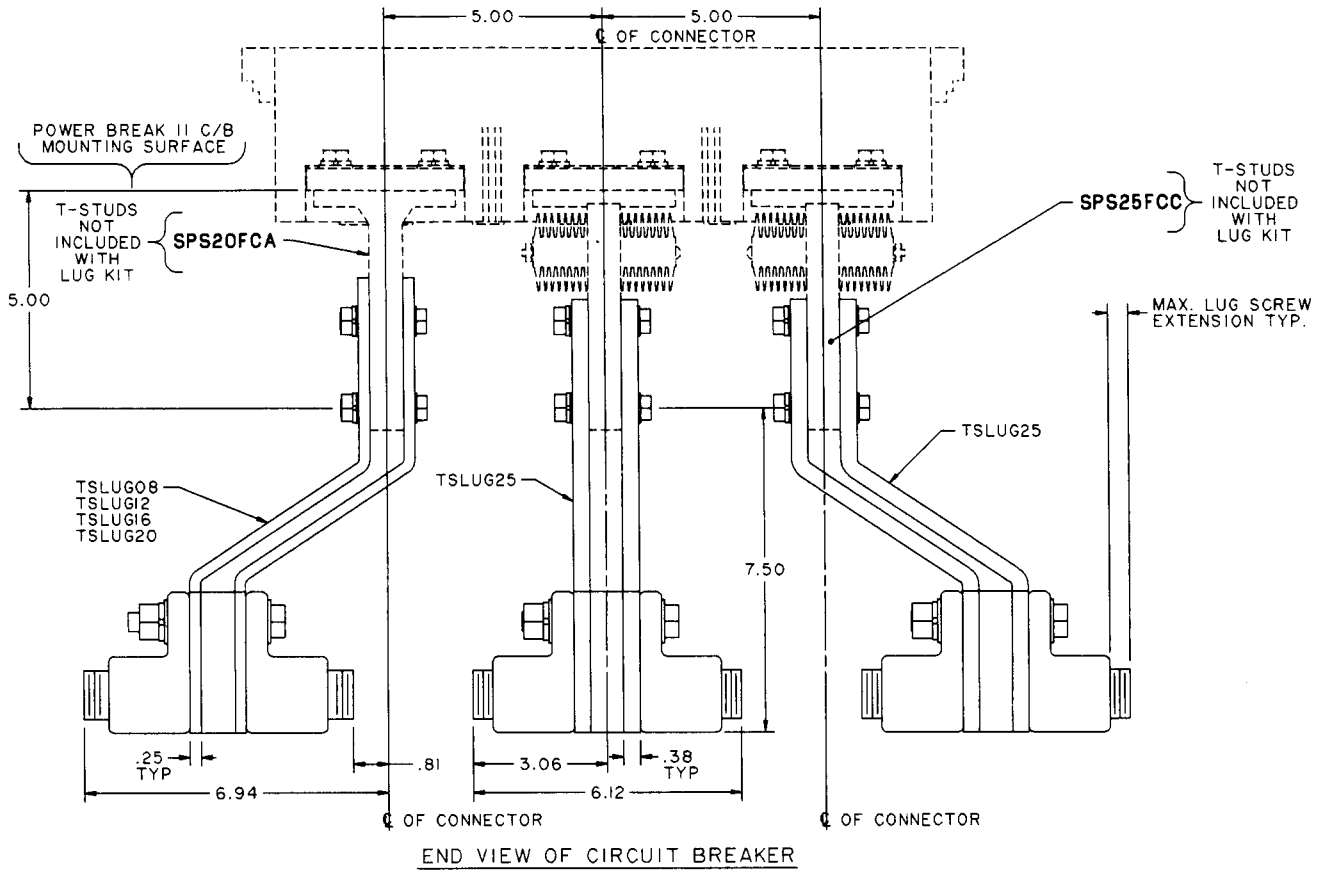

1. Lug kit contains complete 3 pole line or load connection.
2. SPS20BCA and SPS25BCC back connected studs for use with back connected Power Break II circuit breakers.
3. SPS20FCA and SPS25FCC front connected studs for use with front connected Power Break II circuit breakers.

Physical Data

Power Break® II Lug Kits for 2500A Frame

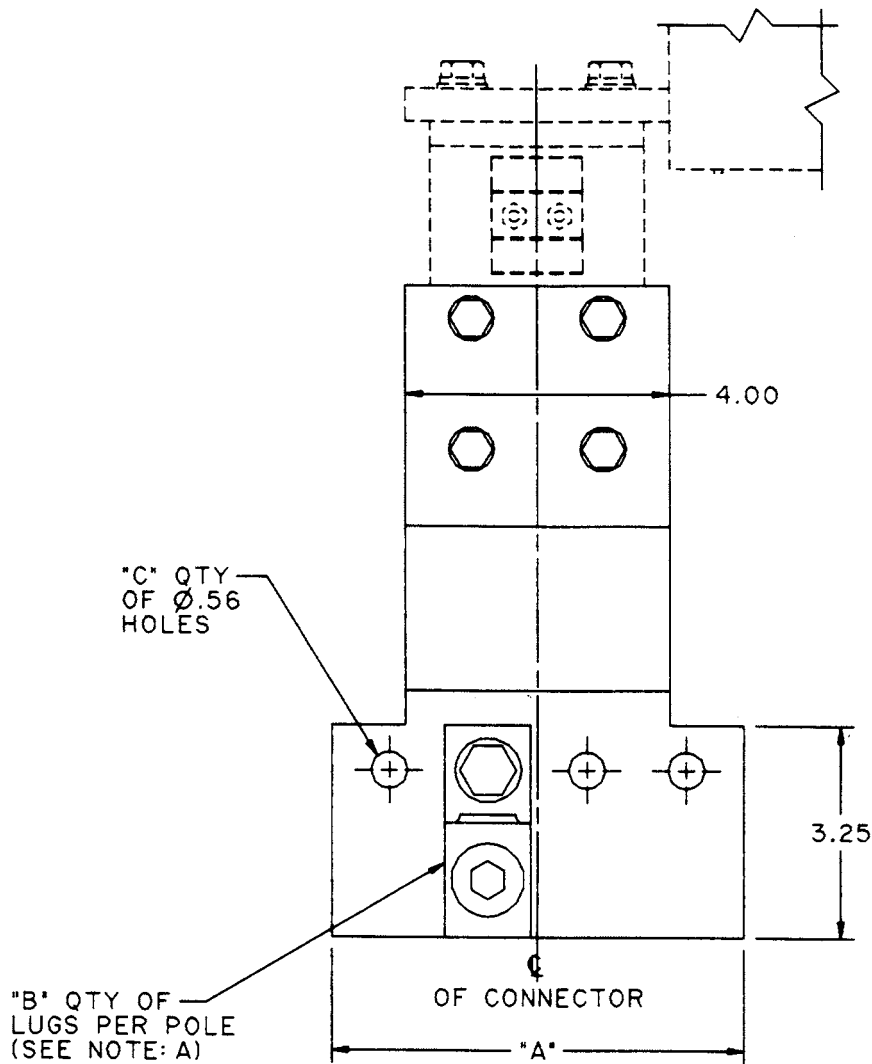

Catalog No.	Amps	"A"	"B"	"C"	Use with Connector Catalog No.
TSLUG08	800	4.00	3	2	SPS20BCA (See Note: B) & SPS20FCA (See Note: C)
TSLUG12	1200	4.00	4	2	
TSLUG16	1600	4.50	5	3	
TSLUG20	2000	4.50	6	3	
TSLUG25	2500	6.25	7	4	SPS25BCC (See Note: B) & SPS25FCC (See Note: C)

Note A: Lug kit contains complete 3 pole line or load connection.

Note B: SPS20BCA and SPS25BCC back connected studs for use with back connected Power Break II circuit breakers.

Note C: SPS20FCA and SPS25FCC front connected studs for use with front connected Power Break II circuit breakers.

Physical Data

Power Break® II Lug Kits For 3000-4000A Frames

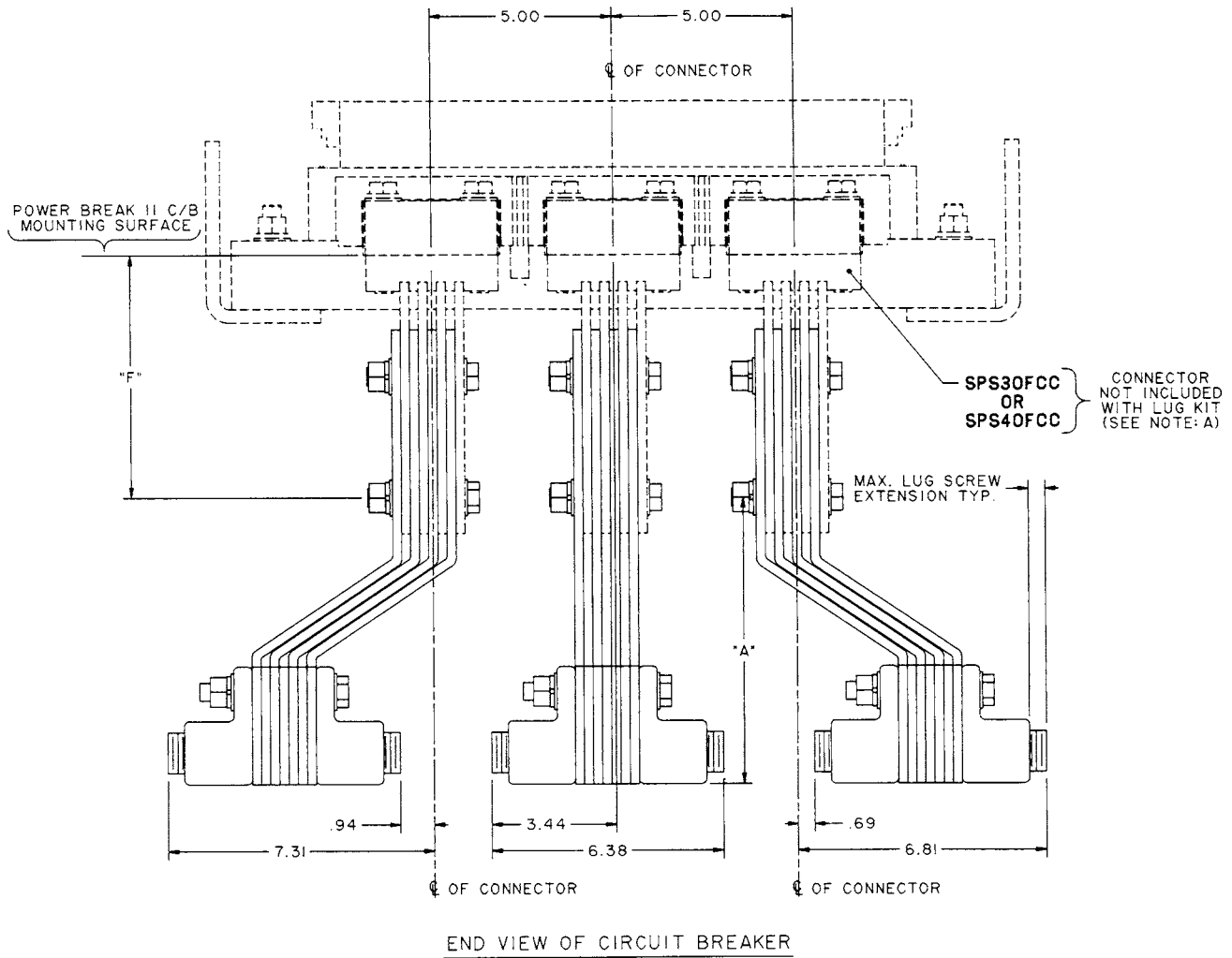

Note A: 3000 Amp back connected circuit breaker has non-removable integral connectors.

Note B: Lug kit contains complete 3 pole line or load connection as shown.

Note C: SPS30FCC and SPS40FCC front connected studs for use with front connected Power Break II circuit breakers.

Physical Data

Power Break® II Lug Kits for 3000-4000A Frames

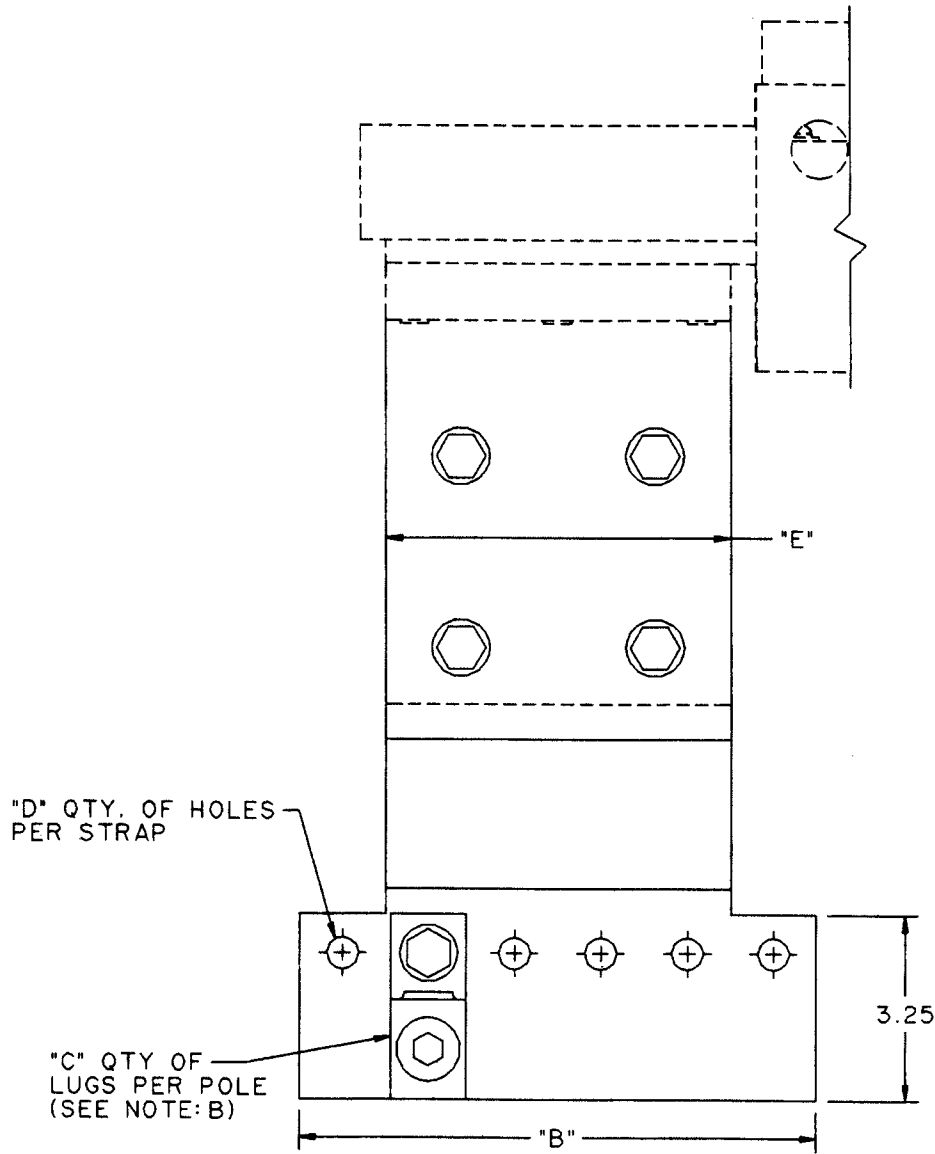

Catalog No.	Amps	"A"	"B"	"C"	"D"	"E"	"F"	Use with Connector Catalog No.
TSLUG30	3000	7.50	7.50	9	5	4.00	5.31	SPS30FCC (See Notes A & B)
TSLUG40	4000	7.94	9.00	11	4	6.00	6.75	SPS40FCC (See Note C)

Note A: 3000 Amp back connected circuit breaker has non-removable integral connectors.

Note B: Lug kit contains complete 3 pole line or load connection as shown.

Note C: SPS30FCC and SPS40FCC front connected studs for use with front connected Power Break II circuit breakers.

Physical Data

Power Break® II UVR/ST Transformer For 480V And 600V Accessories

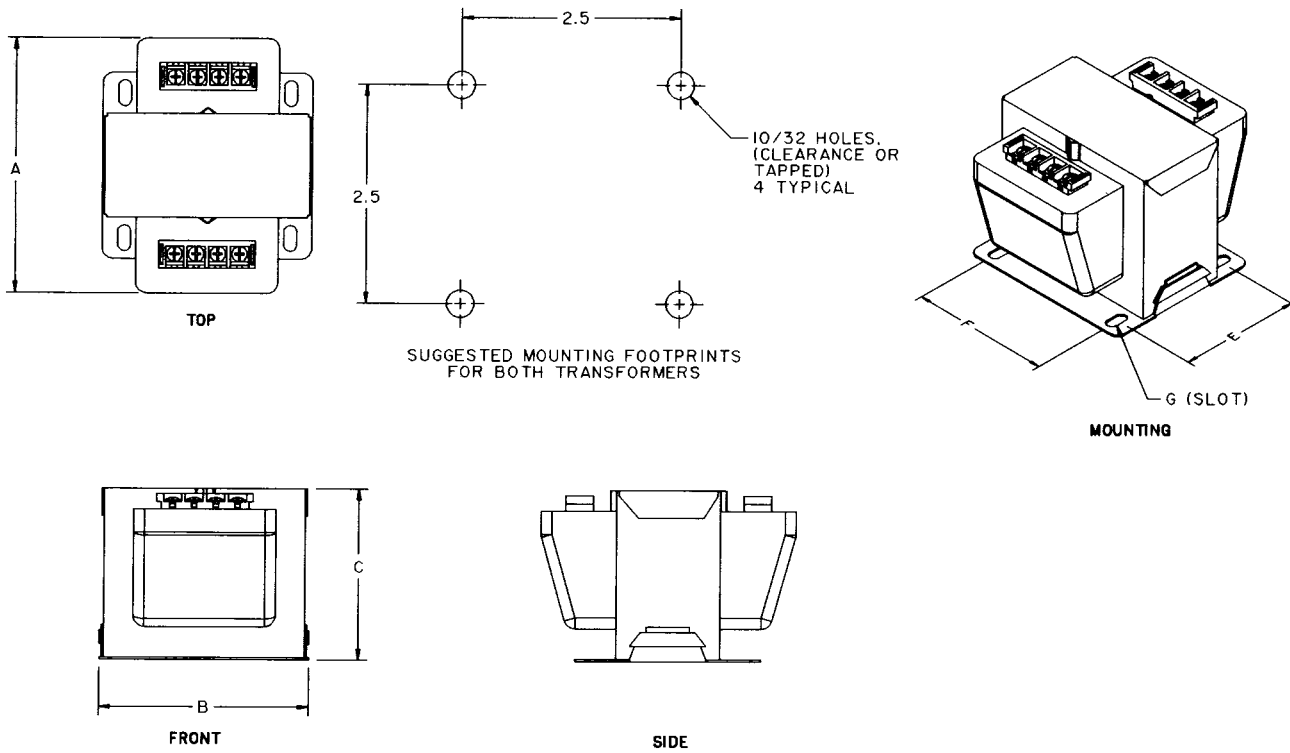

Part	Ge Xfmr. Cat. No.	Voltage	Ref 60Hz kVA	Approx. Weight (lbs.)	Maximum Envelope			Mounting		
					Dept	Width	Height	Depth	Width	Height
					A	B	C	D	E	F
P1	9T58K0042	480V	.050	2.6	3.97	3.29	2.79	2.16	2.50	.219 x 7.50
P2	9T58K0062	600V	.087	3.4	4.47	3.29	2.79	2.66	2.50	.219 x .750

Physical Data

Power Break® II Enclosure, 800A Frame

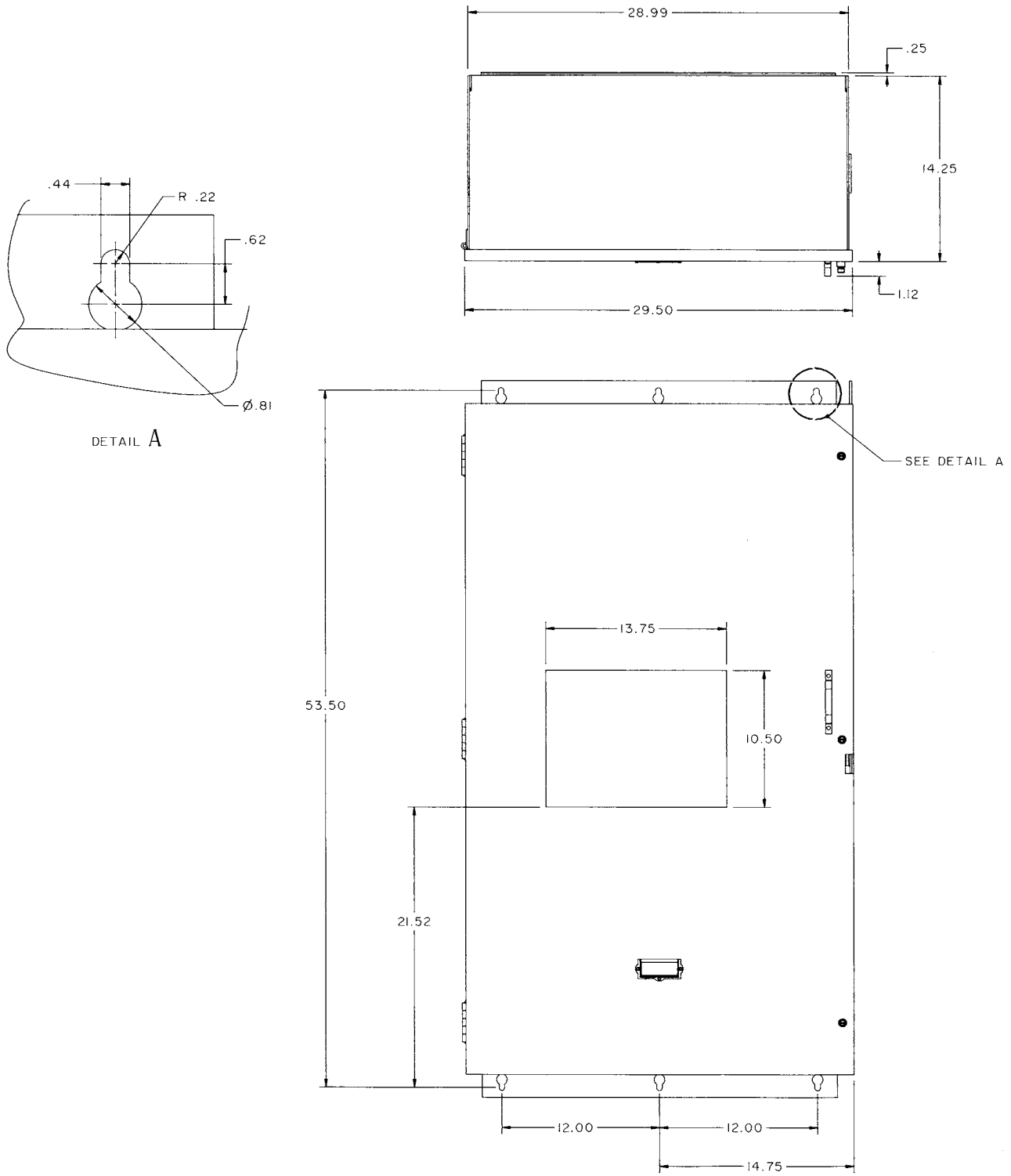

Physical Data

Power Break® II Enclosure, 800A Frame

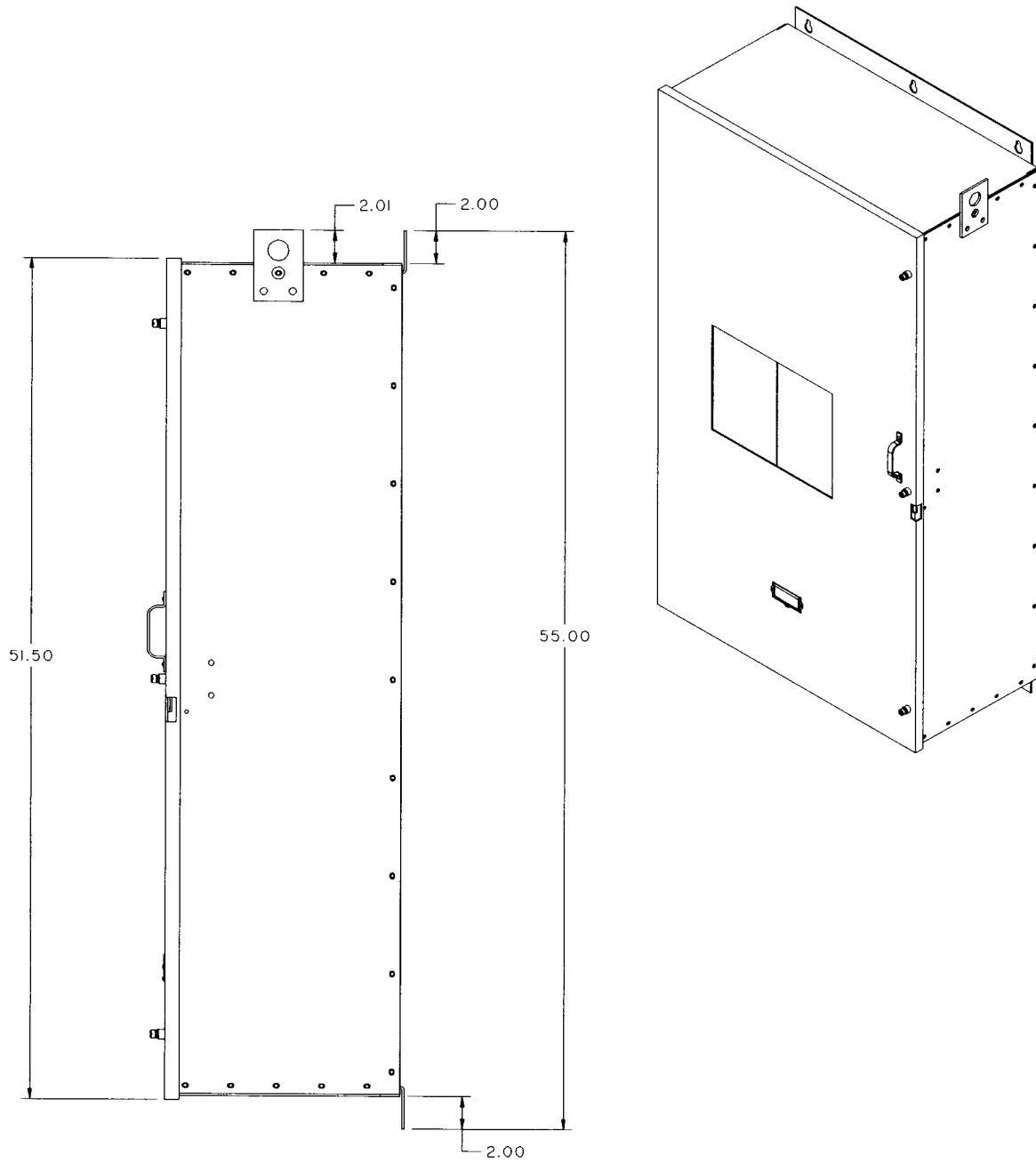

Physical Data

Power Break® II Enclosure, 1600A And 2000A Frames

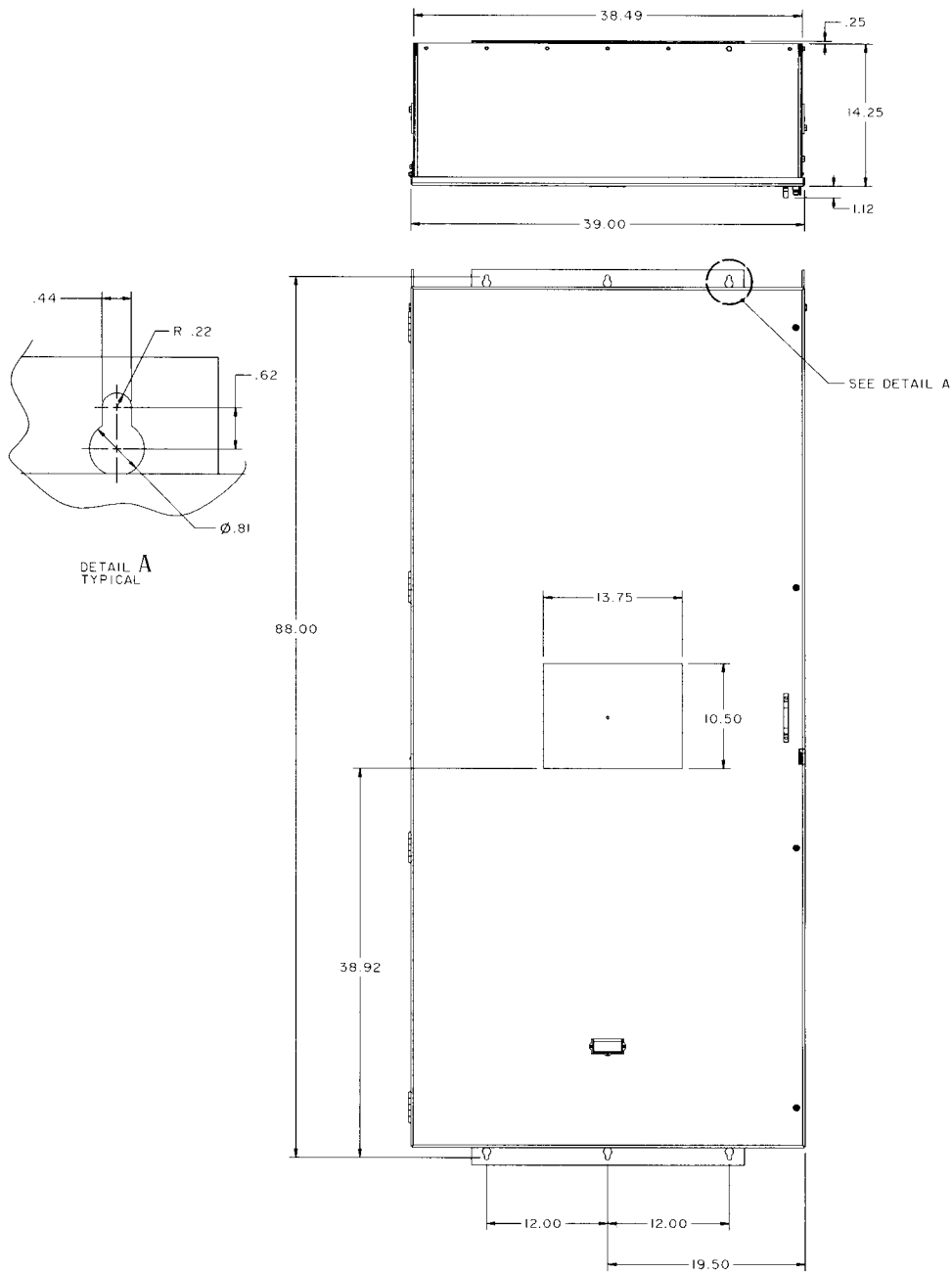

Physical Data

Power Break® II Enclosure, 1600A And 2000A Frames

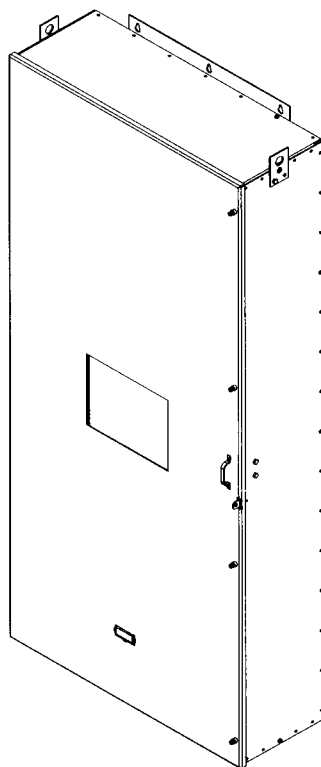
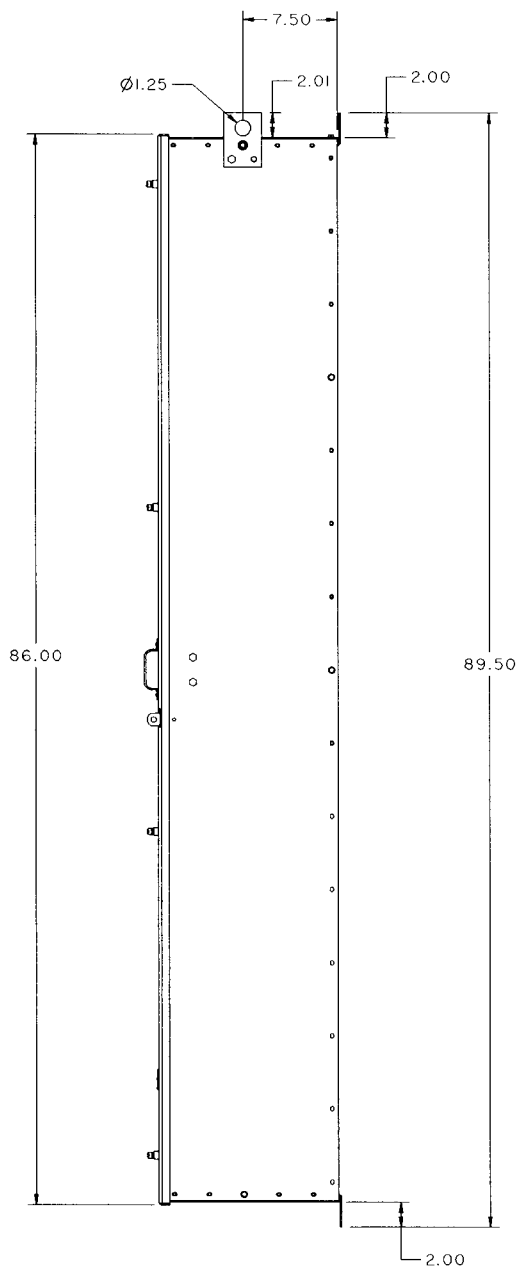

Physical Data

Table 117.1
Outline Drawings – Circuit Breakers

Frame Rating (amps)	Stationary Breaker Outline Drawing GEM 3025	Drawout Breaker Outline Drawing GEM 3025
800	SH1, 5, 6, 14	SH3, 5, 6, 15
1600	SH2, 5, 6, 14	SH4, 5, 6, 15
2000	SH2, 5, 6, 14	SH4, 5, 6, 15
2500	SH6, 7, 9, 13, 16	SH6, 11, 13, 19
3000	SH6, 7, 10, 13, 16	SH6, 11, 13, 19
4000	SH6, 8, 13, 17	SH6, 12, 13, 18

Table 117.2
Outline Drawings – T-Studs For Stationary Breakers

Frame Size	Max Amp Rating	T-Stud Catalog Number		Outline Drawing GEM 3027
		Front Connected	Back Connected	
800	800	SP08FCA, SP08FCC	—	SH1
1600	1600	SP20FCA, SP20FCC	—	SH2
2000	2000	SP20FCA, SP20FCC	—	SH2
2500	2000	SPS20FCA	—	SH3
	2000		SPS20BCA	SH5
	2500	SPS25FCC		SH3
	2500		SPS25BCC	SH5
3000	3000	SPS30FCC	Supplied as standard- not removable	SH3
4000	4000	SPS40FCC, SPS40LFCC	—	SH4

Table 117.3
Outline Drawings – Lug Kits for Stationary Breakers

Frame Size	Maximum Ampere Rating	Lug Kit Catalog Number	Outline Drawing GEM 3026
3000	800	TSLUG08	SH4
	1200	TSLUG12	SH4
	1600	TSLUG16	SH4
	2000	TSLUG20	SH4
	2500	TSLUG25	SH4
	3000	TSLUG30	SH5
4000	4000	TSLUG40	SH5

Table 117.4
Outline Drawings – Neutral Sensors For Power+™, MicroVersa Trip Plus™ And MicroVersaTrip PM™ Units

Breaker Frame Amps	Sensor Rating ^① (amps)	Catalog Number	Outline Drawing Number		
800	200 400/200 600/300 ^② 800/400	TSVG302 TSVG304A TSVG306A TSVG308A	139C5016SHI		
	1600	800/400 ^② 1000/500 1200/600 ^② 1600/1000		TSVG808A TSVG810A TSVG812A TSVG816A	
2000		2000/1000		TSVG20A	
2500/300		800/400 ^② 1000/500 1200/600 ^② 1600/1000 ^② 2000/1200 2500/1800 3000/2400		TSVG808A TSVG810A TSVG812A TSVG816A TSVG820A TSVG825A TSVG830A	
	4000	4000/3000		TSVG940A	139C5016SH2

① Match neutral current sensor rating (or tap setting) to circuit breaker sensor rating.

② For use with multiple-source ground-fault protection schemes. Rating does not match MicroVersaTrip® Trip Unit frame sensor.

Table 117.5
Outline Drawings Lug Adapter Kits For Stationary Breakers

Maximum Ampere Rating	Adapter Kit Catalog Number	Outline Drawing GEM 3026
800 A	TPLUGA08	SH1
1600 A	TPLUGA16	SH2
2000 A	SPLUGA20	SH3

Physical Data

Table 118.1
Outline Drawings – Enclosures

Enclosure Catalog Number	Frame Rating	Lugs Per Pole	Lugs Wire Range (kcmil, CU/AL)	Outline Drawing GEM 3133
SPB08W	800 A	6	#2-600 or (2) #1/0-250	SH1
SPB16W	1600 A	12	#3/0-800	SH2
SPB20W	2000 A	14	#3/0-800	SH2

Table 118.2
Weight And Space Requirements

Frame Rating	Breaker Type	Weight		Minimum Compartment Volume	Minimum Door Ventilation	
		Breaker	Drawout Substructure			
800A	Stationary Mounted	71 Lbs. * (32.3 Kg)	N/A	3447 Cu. In. (56,486 Cu. Cm)	None	
1600A		79 Lbs. * (35.9 Kg)			60.0 Sq In. (387.1 Sq. Cm) Total 30.0 Sq In. (193.5 Sq Cm) Top 30.0 Sq In. (193.5 Sq Cm) Bottom	
2000A					86.4 Sq. In. (557.4 Sq. Cm) Total 43.2 Sq. In. (278.7 Sq Cm) Top 43.2 Sq. In. (278.7 Sq Cm) Bottom	
800A	Drawout Mounted	106 Lbs.* (48.2 Kg)	54 Lbs (24.5 Kg)	3780 Cu. In (61,943 Cu. Cm)	None	
1600A		125 Lbs. * (56.8 Kg)	68 Lbs. (30.9 Kg)	5670 Cu. In (82,915 Cu. Cm)	None	
2000A					34.2 Sq. In (220.6 Sq. Cm) Total 29.5 Sq. In. (190.3 Sq. Cm) Top 4.66 Sq. In. (30.0 Sq. Cm) Bottom	
2500A	Back Connected	167 Lbs. (76 Kg)*	N/A	13,950 Cu. In. (228,600 Cu. Cm)	160 Sq. In. (1032 Sq. Cm) Total 80 Sq In. (516 Sq. Cm) Top 80 Sq In. (516 Sq. Cm) Bottom	
	Front Connected	178 Lbs. (81 Kg) *			270 Sq In. (1742 Sq. Cm) Total 135 Sq. In. (871 Sq. Cm) Top 135 Sq. In. (871 Sq. Cm) Top	
3000A	Back Connected	216 Lbs. (81.4 Kg) *		20,832 Cu. In. (341,375 Cu. Cm)	25,143 Cu. In 412,020 Cu. Cm)	270 Sq In. (1742 Sq. Cm) Total 135 Sq. In. (871 Sq. Cm) Top 135 Sq. In. (871 Sq. Cm) Top
	Front Connected	179 Lbs. (81.40) *				270 Sq In. (1742 Sq. Cm) Total 135 Sq. In. (871 Sq. Cm) Top 135 Sq. In. (871 Sq. Cm) Top
4000A	Front Connected	320 Lbs. (145.6 Kg)*				
2500A	Drawout Mounted	232 Lbs. (105.6 Kg)*		111 Lbs. (50.5 Kg)	10,991 Cu. In. (180,108 Cu. Cm)	246 Sq. In. (1587 Sq Cm) Total 123 Sq. In. (793.5 Sq Cm) Top 123 Sq. In. (793.5 Sq. Cm) Bottom
3000A		233 Lbs. (106 Kg) *	111 Lbs. (50.5 Kg)	10,991 Cu. In. (180,108 Cu. Cm)	246 Sq. In. (1587 Sq Cm) Total 123 Sq. In. (793.5 Sq Cm) Top 123 Sq. In. (793.5 Sq. Cm) Bottom	
4000A		259 Lbs. (134.2 Kg)*	167 Lbs (76 Kg)	15,138 Cu. In. (248,074 Cu. Cm)	246 Sq. In. (1587 Sq Cm) Total 123 Sq. In. (793.5 Sq Cm) Top 123 Sq. In. (793.5 Sq. Cm) Bottom	

N/A = Not Applicable * Add 9 lbs. (4.1 Kg) for electrical operator

Standards and References

Underwriters Laboratories® (UL)

Publication Stock, 333 Pfingsten Road
Northbrook, IL 60062 USA

Standard UL 489 and UL 489-SB2 Molded Case Circuit Breakers and Circuit Breaker Enclosures

National Electrical Manufacturers Association (NEMA)

NEMA Publication, 155 East 44th Street,
New York, NY 10017 USA

AB-1 Standards Publication, Molded Case Circuit Breakers

Institute of Electrical and Electronics Engineers (IEEE)

ICEE, 345 East 47th Street,
New York, NY 10017 USA

American National Standard Institute (ANSI)

ANSI, 11 West 42nd Street,
New York, NY 10036 USA

ANSI/IEEE C37.90.1 – 1989

*IEEE Standard Surge Withstand Capability (SWC)
Tests for Protective Relays and Relay Systems*

ANSI/IEEE C37.90.2 – 1993

Withstand Capability of Relay Systems to Radiated Electromagnetic Interference from Transceivers

International Electrotechnical Committee (IEC)

Bureau Central de la Commission
Electrotechnique Internationale
3 rue de Varamb'è
Geneve, SUISSE

IEC 801-2 2nd Edition 1991-04

*Electromagnetic Compatibility for Industrial-Process
Measurement and Control Equipments
Part 2: Electrostatic Discharge Requirements*

National Electrical Code®

Order from National Fire Association
Batterymarch Park
Quincy, MA 02269

American Society for Testing and Materials (ASTM)

1916 Race Street
Philadelphia, PA 19103 USA

ASTM B117-73 (Reapproved 1979)

Standard Method of Salt Spray (Fog) Testing

Military Standard (MIL-STD)

Defense Printing Service
700 Robbins Avenue, Bldg. 4D
Philadelphia, PA 19111-5094 USA

MIL-STD-810E

Environmental Test Methods and Engineering Guidelines

Guide Form Specifications

General Requirements

Circuit Breakers shall be of insulated case construction. They shall be UL Listed under Standard UL 489, UL 489-SB2, CSA Certified, and IEC 947-2 Certified and shall meet the requirements of NEMA Standard AB1.

Circuit breakers shall be (manually) (electrically) operated, (drawout) (stationary) mounted with features and accessories described in these requirements. Breakers shall have a minimum voltage rating of 600 Vac, and shall be rated to carry 100% of the current rating of the breaker continuously.* Breakers shall have minimum UL Listed interrupting ratings as indicated on the drawings. All manually operated breakers shall be field convertible to electrical operation by means of the addition of an internally mounted electrical operator. Addition of an electrical operator shall not change the physical dimensions of a breaker.

Circuit breakers shall be constructed of a high-strength, glass-reinforced insulating case. Construction shall provide a double level of insulation between primary current-carrying parts and operating personnel. The interrupting mechanism shall contain arc chutes with steel vent grids to suppress arcs and cool vented gases. Interphase barriers shall be included to completely isolate each pole. For each breaker, the close and latch rating shall be equal to its short-time rating to help assure selectivity with downstream devices when closing into a fault.

Breakers shall contain a true two-step stored energy operating mechanism providing quick-make, quick-break operation capable of charging-after-closing operation. It shall be possible to discharge the closing spring without closing the main contacts. The maximum closing time shall be three cycles at nominal voltage.

Attempting to close a circuit breaker while an accessory undervoltage release is de-energized or, while a shunt trip with lockout is energized, or while a bell alarm with lockout is activated, shall result in a "kiss-free" operation of the contacts. Common tripping of all poles shall be standard. Breakers shall be capable of a minimum of 10,000 mechanical open and close operations without any required service.

When drawout breakers are in the fully withdrawn position, there shall be provisions for tilting the breakers for inspection, maintenance or removal. It shall be possible to replace the primary disconnect fingers with the breakers in the withdrawn position.

Each breaker shall include a retractable charging handle, close pushbutton, open pushbutton, closing spring charge/discharge indicator and breaker ON/OFF indicator mounted on the front of the breaker. Each breaker shall have as standard, a padlocking provision to prevent closing the breaker when padlocks are installed. Padlocking provisions shall accept up to three padlocks with 1/4" to 3/8" diameter shanks.

This provision shall meet OSHA and California Code (EUSERC) requirements.

Each stationary and drawout breaker shall have provisions for up to 72 dedicated secondary terminal points. All disconnected points shall be capable of being probed from the front of the breaker. All breaker control and accessory wiring, including wiring for future accessories, shall be pre-wired to integral terminal blocks which shall be clearly identified by number and function. Each terminal point shall have space available for two AWG#18#12 wires per terminal and customer circuit identification.

Each circuit breaker shall contain the following accessories (shunt trip with or without lockout) (undervoltage release) (bell alarm) (bell alarm with lockout) [(4 or 8 or 12 stage) SPDT auxiliary switches] (remote close solenoid) (remote "charged" indicator). All accessories shall be field installable. Field installation of shunt trip (with or without lockout), undervoltage release, bell alarms – with and without lockout shall require no adjustments, no internal wiring and no removal of the circuit breaker cover. The bell alarm and bell alarm with lockout shall each contain a mechanical target, which shall extend from the front cover when the device operates. The bell alarm (alarm only) shall reset automatically when the breaker is closed. The bell alarm with lockout must be reset by depressing the mechanical pop-out target before the breaker can be closed. The bell alarm and the bell alarm with lockout shall be independently field-configurable to operate in response to an overcurrent and/or protective relay operation, plus any combination of shunt trip and/or undervoltage release operation – including no response to a protection trip, shunt tripping or undervoltage release trip. Note: for the Power+™ trip unit, the bell alarm and bell alarm with lockout respond to an overcurrent operation only. The shunt trip (with or without lockout) shall be continuously rated with no requirements for a cut-off switch.

Each circuit breaker shall contain the following mechanical accessories (operation counter) (sealable limited access "ON" and "OFF" pushbutton cover) [(1, or 2 or 3 or 4) cylinder key interlock provision] (shutters to cover drawout/stationary primary disconnects when the breaker is racked out) (racking padlock provision to prevent operation of the breaker racking mechanism) (door interlock with defeat mechanism to prevent opening the hinged breaker compartment door when the breaker is closed) (walking beam interlock for stationary breakers to prevent two adjacent breakers from being on at the same time) (mechanical interlock for drawout breakers to prevent two adjacent breakers from being on at the same time). All mechanical accessories shall be capable of being field installed.

* 4000A Stationary 80% rated.

Guide Form Specifications

Breaker Protective System (MicroVersaTrip Plus™ and MicroVersaTrip PM™)

1. Each circuit breaker shall be equipped with a protective trip unit system to protect against overloads, short circuits (and ground faults) as specified in the following subparagraphs. The protective trip unit shall consist of a solid-state, microprocessor-based, programmer; tripping means; current sensors; power supply and other devices as required for proper operation.
2. As a minimum, the trip unit shall have the following features and functions:
 - a) The housing shall be a metallic enclosure to protect against magnetic interference, dust and other contaminants.
 - b) The protective system shall have reliable programmable controls with repetitive accuracy and precise unit settings.
 - c) All current sensing shall employ true rms technology for detecting overloads, (short-time overcurrent conditions), high-level instantaneous overcurrent conditions, (and ground-fault conditions).
 - d) A high-contrast, liquid crystal display – LCD – unit shall display settings, trip targets, and specified metering displays. The trip unit shall be equipped with long-life lithium batteries – with automatic time delay shut-off features – to provide both programming and observation of trip targets or other functions when the breaker is de-energized.
 - e) A multi-button keypad to provide local set-up and readout on the LCD of all trip settings.
 - f) UL Listed, CSA Certified, IEC 947-2 Certified, field-installable, interchangeable rating plugs. It shall not be necessary to change or remove the trip unit to change the trip rating. Rating plugs shall contain rejection features to prevent installation of a plug with an incorrect current sensor rating.
 - g) Integral test jack for connection of a battery pack or test kit to the breaker.
 - h) (When specified) the ground-fault function shall contain a memory circuit to integrate low-level arcing fault currents with time to sum intermittent ground-fault current spikes.
 - i) A mechanism with provisions for sealing the rating plug, the trip unit, and the “ENTER” key on the protective trip unit to make the installation tamper-resistant.
 - j) The unit shall be dual-rated for both 50Hz and 60Hz operation. Noise immunity shall meet the requirements of ANSI Standard C37.90.2
 - k) The trip unit shall have an integral, resettable trip counter to record the number of long-time, short-time, instantaneous and ground-fault trips.
 - l) The trip unit shall display trip targets for long-time, short-time, instantaneous and ground-fault trips.
3. The trip units for the main and tie breakers shall include the following protective functions:
 - a) Adjustable long-time current settings.
 - b) Adjustable long-time delay with four time delay bands.
 - c) Long-time pickup warning indicator.
 - d) Trip targets for long-time, instantaneous (and short-time, when specified), and ground fault (when specified).
 - e) SELECT ONE OF THE FOLLOWING
 - 1) Adjustable instantaneous pickup.
 - 2) Adjustable short-time pickup and delay, with three delay bands, and switchable I²t ramp and adjustable instantaneous pickup.
 - 3) Fixed high-range instantaneous pickup.
 - f) OPTIONAL: Adjustable ground-fault pickup and time delay, with three delay bands and switchable I²t ramp.
 - g) OPTIONAL: Zone-selective interlocking [SELECT ONE] (for ground-fault conditions) (for both ground-fault and short-time conditions).
4. The trip units for feeder breakers shall include the following protective functions:
 - a) Adjustable long-time current settings
 - b) Adjustable long-time delay with four time delay bands.
 - c) Long-time pickup warning indicator.
 - d) Trip targets for long-time, instantaneous (and short-time, when specified), and ground fault (when specified).
 - e) SELECT ONE OF THE FOLLOWING
 - 1) Adjustable instantaneous pickup.
 - 2) Adjustable short-time pickup and delay, with three delay bands, and switchable I²t ramp and adjustable instantaneous pickup.
 - 3) Fixed high-range instantaneous pickup.
 - f.) OPTIONAL: Adjustable ground-fault pickup and time delay, with three delay bands and switchable I²t ramp.
 - g.) OPTIONAL: Zone-selective interlocking [SELECT ONE] (for ground-fault conditions) (for both ground-fault and short-time conditions).

Guide Form Specifications

5. The trip units shall include the following metering functions, which shall be displayed on the LCD:
 - a. Current, rms (A of kA), each phase, $\pm 2.5\%$ accuracy.
 - b. OPTIONAL: Note: If any of the following are included, all will be included.
 - 1) Voltage, rms, (V), line-to-line or line-to-neutral, $\pm 1.5\%$ accuracy.
 - 2) Energy (kWh, MWh, GWh) total, $\pm 4\%$ accuracy, user resettable.
 - 3) Demand (kWh, MWh, GWh) over an adjustable time period of 5 to 60 minutes, $\pm 4\%$ accuracy.
 - 4) Peak demand (kW, MW), $\pm 4\%$ accuracy, user resettable.
 - 5) Real power (kW, MW), line-to-line, line-to-neutral, $\pm 4\%$ accuracy.
 - 6) Total (apparent) power (kVA, MVA), line-to-line, line-to-neutral, $\pm 4\%$ accuracy.
6. OPTIONAL:
The trip unit shall include all of the following protective functions. However, it shall be possible to disable, by user-programming, any combination of unwanted protective functions.
 - a. Undervoltage, adjustable pickup – 50 to 90%, adjustable delay – 1 to 15 seconds.
 - b. Overvoltage, adjustable pickup – 110 to 150%, adjustable delay – 1 to 15 seconds.
 - c. Voltage unbalance, adjustable pickup – 10 to 50%, adjustable delay – 1 to 15 seconds.
 - d. Current unbalance, adjustable pickup – 10 to 50%, adjustable delay – 1 to 15 seconds.
 - e. Reverse power, selectable direction, adjustable pickup-10kW to 990 kW, adjustable delay – 1 to 15 seconds.
7. OPTIONAL: The trip unit shall include communication capability as follows:
 - a. The trip unit through dedicated secondary terminal on the breaker shall provide a communication port for communication with and access to a remote computer via the breaker supplier's standard communication network and protocol.
 - b. All metering, setpoints, protective trip counts and other event signaling shall be retrievable by the remote computer.
8. Current sensors shall be mounted on the breaker frame and shall use encapsulated construction to protect against damage and moisture. (For ground-fault protection of a four-wire power system, a fourth-neutral current- sensor shall be mounted in the cable compartment, and shall be compatible with the phase overcurrent sensors.)
9. The trip unit's LCD and programming functions shall be operable at all times, even when the breaker is either open or closed under a no-load condition. Metering functions, other than current, protective relaying and communication functions may require a separate power supply within the equipment lineup. The external power supply shall meet the breaker supplier's standard recommendations for this type of application.

*With optional Target Module

Guide Form Specifications

Breaker Protective Systems (Power+™ Trip Units)

1. Each circuit breaker shall be equipped with a protective trip unit system to protect against overloads, short circuits (and ground faults) as specified in the following subparagraphs. The protective trip unit shall consist of a solid-state, microprocessor-based, programmer; tripping means; current sensors; power supply and other devices as required for proper operation.
2. As a minimum, the trip unit shall have the following features and functions:
 - a. The housing shall be a metallic enclosure to protect against magnetic interference, dust and other contaminants.
 - b. The protective system shall have reliable programmable controls with repetitive accuracy and precise unit settings.
 - c. All current sensing shall employ true rms technology for detecting overloads, (short-time overcurrent conditions and ground-fault conditions).
 - d. The trip unit shall be equipped with long-life lithium batteries – with automatic time delay shut-off features – to provide observation of trip targets.*
 - e. UL 489 and UL 489-SB2 Listed, CSA Certified, IEC 947-2 Certified, field-installable, interchangeable rating plugs. It shall not be necessary to change or remove the trip unit to change the trip rating. Rating plugs shall contain rejection features to prevent installation of a plug with an incorrect current sensor rating.
 - f. Integral test jack for connection of a battery pack or test kit to the breaker.
 - g. (When specified) the ground-fault function shall contain a memory circuit to integrate low-level arcing fault currents with time to sum intermittent ground-fault current spikes.
 - h. A mechanism with provisions for sealing the rating plug and trip unit to make the installation tamper-resistant.
 - i. The unit shall be dual-rated for both 50Hz and 60Hz operation. Noise immunity shall meet the requirements of ANSI Standard C37.90.2
 - j. The trip unit shall display trip targets for long-time, short-time, instantaneous and ground fault*.
3. The trip units for the main and tie breakers shall include the following protective functions:
 - a. Adjustable long-time current settings.
 - b. Adjustable long-time delay with four time delay bands.
 - c. Long-time pickup warning indicator*
 - d. Trip targets for overload, short circuit (when specified), and ground fault (when specified).*
 - e. SELECT ONE OF THE FOLLOWING:
 - 1) Adjustable instantaneous pickup.
 - 2) Adjustable short-time pickup and delay, with three delay bands, and switchable I²t ramp and adjustable instantaneous pickup.
 - f. OPTIONAL: Adjustable ground-fault pick-up and time delay, with three delay bands, and switchable I²t ramp.
4. The trip units for feeder breakers shall include the following protective functions:
 - a. Adjustable long-time current settings.
 - b. Adjustable long-time delay with four time delay bands.
 - c. Long-time pickup warning indicator.*
 - d. Trip targets for overload, short circuit (when specified), and ground fault (when specified)
 - e. SELECT ONE OF THE FOLLOWING:
 - 1) Adjustable instantaneous pickup.
 - 2) Adjustable short-time pickup and delay, with three delay bands, and switchable I²t ramp and adjustable instantaneous pickup.
 - f. OPTIONAL: Adjustable ground-fault pickup and time delay, with three delay bands, and switchable I²t ramp.
5. Current sensors shall be mounted on the breaker frame and shall use encapsulated construction to protect against damage and moisture. (For ground-fault protection of a four-wire power system, a fourth – neutral current – sensor shall be mounted in the cable compartment, and shall be compatible with the phase overcurrent sensors.)

*With optional Target Module

Other Related Publications

Power Break® Insulated Case Circuit Breakers

Power Break II Circuit Breaker Installation, Operation and Maintenance	GEH-6270
Power Break II into a Power Break I: Retrofit Kit	DEA-520
Power+™ Trip Units	DEH-049

EntelliGuard® TU Trip Units

EntelliGuard TU Trip Unit	DEA-4461
EntelliGuard Supplement Instructions	DEH-3456
Trip Unit Installation Instructions	DEH-4567
EntelliGuard TU Conversion Kit Brochure	DET-722B
EntelliGuard TU Conversion Kit Brochure	DET-722C

MicroVersaTrip Plus™ and MicroVersaTrip PM™ Trip Units

MicroVersaTrip Plus and MicroVersaTrip PM Trip Units, Instructions	GEH-6273
Voltage Conditioners for MicroVersaTrip Plus and MicroVersaTrip PM Units, Instructions	GEH-6254
24Vdc Power Supply for MicroVersaTrip Plus and MicroVersaTrip PM Trip Units, Instructions	GEH-6253

Power Leader™ Power Management

POWER LEADER Power Management System	DEA-018
POWER LEADER Display Meter	DE-326
POWER LEADER Monitor	DE-334
POWER LEADER Repeater	DE-333
POWER LEADER Communication Network Interface (CNI) Card	DET-001
POWER LEADER Communication Junction Box	DET-011
POWER LEADER Product Interface Module	DET-025
POWER LEADER PCM/Gateway Module	DET-013
POWER LEADER Distribution Software	DET-002
POWER LEADER Distribution Software Packages	DET-003
POWER LEADER Distribution Software – Computer Guide	DEE-001

Spectra Series™ Switchboards

Spectra Series Switchboards	GET-8032
Auto Throwover Equipment for Spectra Series and AV-Line Switchboards	GEA-10261

Ground Break® Ground Fault Relay System

GROUND BREAK Ground Fault Relay System	GE-2964
--	---------

Notes

Information contained in this application guide is based on established industry standards and practices. It is published in the interest of assisting preparation of plans and specifications for insulated case circuit breakers. Neither the General Electric Company nor any person acting on its behalf assumes any liability with respect to the use of, or for damages or injury resulting from the use of any information contained in this application guide.

GE Energy
41 Woodford Avenue
Plainville, CT 06062

Power Break is a registered trademark of the General Electric Company

© 2011 General Electric Company
www.geindustrial.com

