

Left Side View

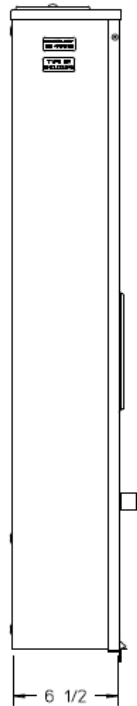

Front View Interior

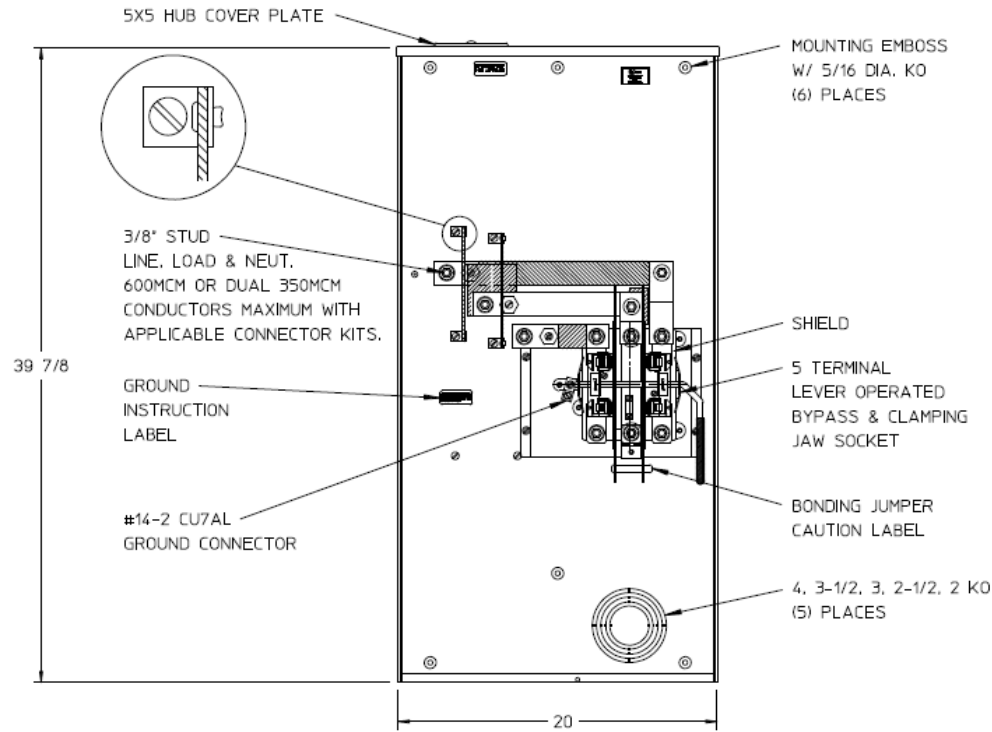

Right Side View

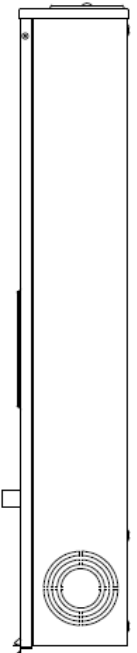

STAINLESS STEEL RIBBON SEAL ROTARY LATCH

Notes

- 1) FINISH: GRAY
- 2) CABINET: BACK IS FABRICATED FROM 14 GA GALV STEEL. TOP, BOTTOM, & FRONT IS FABRICATED FROM 16 GA GALV STEEL.
- 3) 320 AMP CONTINUOUS 600 VAC, 3 PHASE, 3 WIRE NETWORK, 3 WIRE 1 PHASE, 3 WIRE 320 AMP BYPASS
- 4) MIDWEST LABEL ATTACHED TO THE END OF CARTON.
- 5) TEMPORARY CARDBOARD METER OPENING COVER PROVIDED.
- 6) MIDWEST LOGO STAMPED IN THE LOWER LEFT-HAND CORNER OF FRONT.

Bottom View

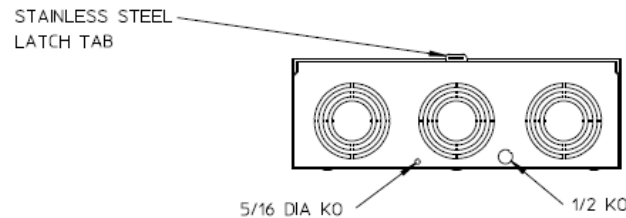

METER SKT-(1) 320A 600V 1P3W G90 N3R 5-TERM TPLX GRD
LARGE HUBCVPLT LEVER BYP TOP/BOT FEED MEG APPROVED

CAT NO	DWG DATE	REV #
UTH5330UFLMEP	06/16/2016	01